



A330

AIRCRAFT CHARACTERISTICS AIRPORT AND MAINTENANCE PLANNING

AC

The content of this document is the property of Airbus.
It is supplied in confidence and commercial security on its contents must be maintained.
It must not be used for any purpose other than that for which it is supplied, nor may
information contained in it be disclosed to unauthorized persons.
It must not be reproduced in whole or in part without permission in writing from the owners of
the copyright. Requests for reproduction of any data in this document and the media authorized
for it must be addressed to Airbus.

© AIRBUS S.A.S. 2005. All rights reserved.

*AIRBUS S.A.S.
Customer Services
Technical Data Support and Services
31707 Blagnac Cedex
FRANCE*

HIGHLIGHTS

Revision No. 30 - Jul 01/21

LOCATIONS	CHG CODE	DESCRIPTIONS OF CHANGE
<u>CHAPTER 2</u>		
Section 2-1		
Subject 2-1-1		
General Aircraft Characteristics Data	R	
Section 2-3		
Subject 2-3-0		
Ground Clearances	R	
FIGURE Ground Clearances	R	ADDED A NOTE RELATED TO THE GROUND CLEARANCE VALUES IN THE TABLE ARE DEPEND ON THE CG POSITION AND AIRCRAFT WEIGHT.
FIGURE Ground Clearances	R	ADDED A NOTE RELATED TO THE GROUND CLEARANCE VALUES IN THE TABLE ARE DEPEND ON THE CG POSITION AND AIRCRAFT WEIGHT.
FIGURE Ground Clearances	R	ADDED A NOTE RELATED TO THE GROUND CLEARANCE VALUES IN THE TABLE ARE DEPEND ON THE CG POSITION AND AIRCRAFT WEIGHT.
FIGURE Ground Clearances	R	ADDED A NOTE RELATED TO THE GROUND CLEARANCE VALUES IN THE TABLE ARE DEPEND ON THE CG POSITION AND AIRCRAFT WEIGHT.
FIGURE Ground Clearances	R	ADDED A NOTE RELATED TO THE GROUND CLEARANCE VALUES IN THE TABLE ARE DEPEND ON THE CG POSITION AND AIRCRAFT WEIGHT.
FIGURE Ground Clearances - Ailerons – Up	R	ADDED A NOTE RELATED TO THE GROUND CLEARANCE VALUES IN THE TABLE ARE DEPEND ON THE CG POSITION AND AIRCRAFT WEIGHT.

LOCATIONS	CHG CODE	DESCRIPTIONS OF CHANGE
FIGURE Ground Clearances - Ailerons – Up	R	ADDED A NOTE RELATED TO THE GROUND CLEARANCE VALUES IN THE TABLE ARE DEPEND ON THE CG POSITION AND AIRCRAFT WEIGHT.
FIGURE Ground Clearances - Ailerons – Down	R	ADDED A NOTE RELATED TO THE GROUND CLEARANCE VALUES IN THE TABLE ARE DEPEND ON THE CG POSITION AND AIRCRAFT WEIGHT.
FIGURE Ground Clearances - Ailerons – Down	R	ADDED A NOTE RELATED TO THE GROUND CLEARANCE VALUES IN THE TABLE ARE DEPEND ON THE CG POSITION AND AIRCRAFT WEIGHT.
FIGURE Ground Clearances - Spoilers – Extended	R	ADDED A NOTE RELATED TO THE GROUND CLEARANCE VALUES IN THE TABLE ARE DEPEND ON THE CG POSITION AND AIRCRAFT WEIGHT.
FIGURE Ground Clearances - Spoilers – Extended	R	
FIGURE Ground Clearances - Leading Edge Slats – Extended	R	ADDED A NOTE RELATED TO THE GROUND CLEARANCE VALUES IN THE TABLE ARE DEPEND ON THE CG POSITION AND AIRCRAFT WEIGHT.
FIGURE Ground Clearances - Leading Edge Slats – Extended	R	
FIGURE Ground Clearances - Trailing Edge Flaps – Extended	R	
FIGURE Ground Clearances - Trailing Edge Flaps – Extended	R	ADDED A NOTE RELATED TO THE GROUND CLEARANCE VALUES IN THE TABLE ARE DEPEND ON THE CG POSITION AND AIRCRAFT WEIGHT.
FIGURE Ground Clearances - Flap Tracks – Extended	R	ADDED A NOTE RELATED TO THE GROUND CLEARANCE VALUES IN THE TABLE ARE DEPEND ON THE CG POSITION AND AIRCRAFT WEIGHT.
FIGURE Ground Clearances - Flap Tracks – Extended	R	ADDED A NOTE RELATED TO THE GROUND CLEARANCE VALUES IN THE TABLE ARE DEPEND ON THE CG POSITION AND AIRCRAFT WEIGHT.

LOCATIONS	CHG CODE	DESCRIPTIONS OF CHANGE
FIGURE Ground Clearances - Flap Tracks - Retracted	R	ADDED A NOTE RELATED TO THE GROUND CLEARANCE VALUES IN THE TABLE ARE DEPEND ON THE CG POSITION AND AIRCRAFT WEIGHT.
FIGURE Ground Clearances - Flap Tracks - Retracted	R	ADDED A NOTE RELATED TO THE GROUND CLEARANCE VALUES IN THE TABLE ARE DEPEND ON THE CG POSITION AND AIRCRAFT WEIGHT.
FIGURE Ground Clearances - Flap Tracks - 1 + F	R	ADDED A NOTE RELATED TO THE GROUND CLEARANCE VALUES IN THE TABLE ARE DEPEND ON THE CG POSITION AND AIRCRAFT WEIGHT.
FIGURE Ground Clearances - Flap Tracks - 1 + F	R	ADDED A NOTE RELATED TO THE GROUND CLEARANCE VALUES IN THE TABLE ARE DEPEND ON THE CG POSITION AND AIRCRAFT WEIGHT.
Section 2-12 Subject 2-12-0 FIGURE Engine and Nacelle - Fan Cows - PW 4000 FIGURE Engine and Nacelle - Thrust Reverser Cows - PW 4000	R R	MODIFIED THE DEGREE (°) SYMBOL FOR THE ANGLE OF FAN COWL DOORS IN OPEN CONDITION. MODIFIED THE DEGREE (°) SYMBOL FOR THE ANGLE OF THRUST REVERSER COWLS IN OPEN CONDITION.
Section 2-14 Subject 2-14-0 FIGURE Jacking for Maintenance - Jacking Points Location	R	
FIGURE Jacking for Maintenance - Jacking Points Location	R	
FIGURE Jacking for Maintenance - Jacking Points Location	R	
FIGURE Jacking for Maintenance - Jacking Points Location	R	
FIGURE Jacking for Maintenance - Jacking Points Location	R	

LOCATIONS	CHG CODE	DESCRIPTIONS OF CHANGE
FIGURE Jacking for Maintenance - Jacking Dimensions	R	
FIGURE Jacking for Maintenance - Jacking Dimensions	R	
FIGURE Jacking for Maintenance - Jacking Dimensions	R	
FIGURE Jacking for Maintenance - Jacking Dimensions	R	
FIGURE Jacking for Maintenance - Jacking Dimensions	R	
<u>CHAPTER 4</u>		
Section 4-1		
Subject 4-1-0		
General Information	R	NOTE AMENDED
Section 4-2		
Subject 4-2-0		
Turning Radii	R	
FIGURE Turning Radii - (Sheet 1)	R	MODIFIED PROPERTY OF THE DEGREE SYMBOLS IN THE ILLUSTRATION.
FIGURE Turning Radii - (Sheet 2)	R	MODIFIED PROPERTY OF THE DEGREE SYMBOL IN THE ILLUSTRATION.
FIGURE Turning Radii - (Sheet 2)	R	MODIFIED PROPERTY OF THE DEGREE SYMBOL IN THE ILLUSTRATION.
FIGURE Turning Radii - (Sheet 1)	R	MODIFIED PROPERTY OF THE DEGREE SYMBOLS IN THE ILLUSTRATION.
FIGURE Turning Radii - (Sheet 2)	R	MODIFIED PROPERTY OF THE DEGREE SYMBOL IN THE ILLUSTRATION.
FIGURE Turning Radii - (Sheet 2)	R	MODIFIED PROPERTY OF THE DEGREE SYMBOL IN THE ILLUSTRATION.
Section 4-3		
Subject 4-3-0		
Minimum Turning Radii	R	

LOCATIONS	CHG CODE	DESCRIPTIONS OF CHANGE
FIGURE Minimum Turning Radii	R	DELETED THE INFORMATION ABOUT MINIMUM TURNING RADII OF 65° (MAX) STEERING ANGLE.
FIGURE Minimum Turning Radii Section 4-5 Subject 4-5-0	R	
Runway and Taxiway Turn Paths Subject 4-5-1	R	NOTE AMENDED
FIGURE 135° Turn - Runway to Taxiway - Judgemental Oversteering Method	R	MODIFIED THE ILLUSTRATION FOR JUDGEMENTAL OVERSTEERING METHOD.
FIGURE 135° Turn - Runway to Taxiway - Cockpit Over Centerline Method	R	
FIGURE 135° Turn - Runway to Taxiway - Judgemental Oversteering Method	R	MODIFIED THE ILLUSTRATION FOR JUDGEMENTAL OVERSTEERING METHOD.
FIGURE 135° Turn - Runway to Taxiway - Cockpit Over Centerline Method Subject 4-5-2	R	MODIFIED THE ILLUSTRATION FOR COCKPIT OVER CENTERLINE METHOD.
FIGURE 90° Turn - Runway to Taxiway - Judgemental Oversteering Method	R	MODIFIED THE ILLUSTRATION FOR JUDGEMENTAL OVERSTEERING METHOD.
FIGURE 90° Turn - Runway to Taxiway - Cockpit Over Centerline Method	R	MODIFIED THE ILLUSTRATION FOR COCKPIT OVER CENTERLINE METHOD.
FIGURE 90° Turn - Runway to Taxiway - Judgemental Oversteering Method	R	MODIFIED THE ILLUSTRATION FOR JUDGEMENTAL OVERSTEERING METHOD.
FIGURE 90° Turn - Runway to Taxiway - Cockpit Over Centerline Method Subject 4-5-3	R	MODIFIED THE ILLUSTRATION FOR COCKPIT OVER CENTERLINE METHOD.
180° Turn on a Runway	R	NOTE AMENDED

LOCATIONS	CHG CODE	DESCRIPTIONS OF CHANGE
FIGURE 180° Turn on a Runway	R	ADDED NLG PATH FOR EDGE IN THE ILLUSTRATION. REPLACED THE APPROX RUNWAY WIDTH VALUE 53.6 m BY 52.6 m AND THE PAVEMENT EDGE CLEARANCE VALUE 4.5 m BY 4.0 m.
FIGURE 180° Turn on a Runway	R	
FIGURE 180° Turn on a Runway	R	
FIGURE 180° Turn on a Runway	R	
Subject 4-5-4		
FIGURE 135° Turn - Taxiway to Taxiway - Judgemental Oversteering Method	R	MODIFIED THE ILLUSTRATION FOR JUDGEMENTAL OVERSTEERING METHOD.
FIGURE 135° Turn - Taxiway to Taxiway - Cockpit Over Centerline Method	R	MODIFIED THE ILLUSTRATION FOR COCKPIT OVER CENTERLINE METHOD.
FIGURE 135° Turn - Taxiway to Taxiway - Judgemental Oversteering Method	R	MODIFIED THE ILLUSTRATION FOR JUDGEMENTAL OVERSTEERING METHOD.
FIGURE 135° Turn - Taxiway to Taxiway - Cockpit Over Centerline Method	R	MODIFIED THE ILLUSTRATION FOR COCKPIT OVER CENTERLINE METHOD.
Subject 4-5-5		
FIGURE 90° Turn - Taxiway to Taxiway - Judgemental Oversteering Method	R	MODIFIED THE ILLUSTRATION FOR JUDGEMENTAL OVERSTEERING METHOD.
FIGURE 90° Turn - Taxiway to Taxiway - Cockpit Over Centerline Method	R	MODIFIED THE ILLUSTRATION FOR COCKPIT OVER CENTERLINE METHOD.
FIGURE 90° Turn - Taxiway to Taxiway - Judgemental Oversteering Method	R	MODIFIED THE ILLUSTRATION FOR JUDGEMENTAL OVERSTEERING METHOD.
FIGURE 90° Turn - Taxiway to Taxiway - Cockpit Over Centerline Method	R	MODIFIED THE ILLUSTRATION FOR COCKPIT OVER CENTERLINE METHOD.
Section 4-7		
Subject 4-7-0		
Minimum Line-Up Distance Corrections	R	CROSS REFERENCED DOCUMENTARY UNIT ADDED/REVISED/DELETED NOTE AMENDED

LOCATIONS	CHG CODE	DESCRIPTIONS OF CHANGE
FIGURE Minimum Line-Up Distance Corrections - 90° Turn on Runway Entry	R	
FIGURE Minimum Line-Up Distance Corrections - 180° Turn on Runway Turn Pad	R	
FIGURE Minimum Line-Up Distance Corrections - 180° Turn on Runway Width	R	
<u>CHAPTER 5</u>		
Section 5-4		
Subject 5-4-1		
Ground Service Connections Layout	R	PART EFFECTIVITY ADDED/REVISED/DELETED
FIGURE Ground Service-Connections Layout	R	ILLUSTRATION REVISED
FIGURE Ground Service-Connections Layout	N	ADDED AN ILLUSTRATION OF THE GROUND SERVICE-CONNECTIONS LAYOUT FOR A330-800 AND A330-900. ILLUSTRATION ADDED
Subject 5-4-9		
Potable Water Servicing	R	ADDED "MAXIMUM" TO THE FILLING PRESSURE FOR THE FWD AND AFT POTABLE WATER TANKS.
Potable Water Servicing	R	ADDED "MAXIMUM" TO THE FILLING PRESSURE FOR THE FWD AND AFT POTABLE WATER TANKS.
Potable Water Servicing	R	ADDED "MAXIMUM" TO THE FILLING PRESSURE FOR THE POTABLE WATER TANK.
Section 5-5		
Subject 5-5-0		
Engine Starting Pneumatic Requirements	R	PART EFFECTIVITY ADDED/REVISED/DELETED
<u>CHAPTER 7</u>		
Section 7-1		

LOCATIONS	CHG CODE	DESCRIPTIONS OF CHANGE
Subject 7-1-0 General Information	R	CROSS REFERENCED DOCUMENTARY UNIT ADDED/REVISED/DELETED
Section 7-2		
Subject 7-2-0		
Landing Gear Footprint	R	
FIGURE Landing Gear Footprint	R	REPLACED 94.8% BY 94.7% OF WEIGHT ON MAIN GEAR GROUP FOR WV025 IN THE LANDING-GEAR FOOTPRINT TABLE.
FIGURE Landing Gear Footprint	R	
FIGURE Landing Gear Footprint	R	
FIGURE Landing Gear Footprint	R	ILLUSTRATION REVISED
FIGURE Landing Gear Footprint	R	ILLUSTRATION REVISED
Section 7-3		
Subject 7-3-0		
Maximum Pavement Loads	R	
FIGURE Maximum Pavement Loads	R	
FIGURE Maximum Pavement Loads	R	
FIGURE Maximum Pavement Loads	R	
FIGURE Maximum Pavement Loads	R	ILLUSTRATION REVISED
FIGURE Maximum Pavement Loads	R	ILLUSTRATION REVISED
Section 7-4		
Subject 7-4-0		
Landing Gear Loading on Pavement	R	CROSS REFERENCED DOCUMENTARY UNIT ADDED/REVISED/DELETED NOTE AMENDED
Section 7-5		
Subject 7-5-0		
Flexible Pavement Requirements - US Army Corps of Engineers Design Method	R	
Section 7-6		
Subject 7-6-0		

LOCATIONS	CHG CODE	DESCRIPTIONS OF CHANGE
Flexible Pavement Requirements - LCN Conversion Section 7-7 Subject 7-7-0	R	
Rigid Pavement Requirements - Portland Cement Association Design Method Section 7-8 Subject 7-8-0	R	
Rigid Pavement Requirements - LCN Conversion Section 7-9 Subject 7-9-0	R	
Aircraft Classification Number - Flexible and Rigid Pavements	R	NOTE AMENDED
FIGURE Aircraft Classification Number - ACN Table	R	
FIGURE Aircraft Classification Number - ACN Table	R	
FIGURE Aircraft Classification Number - ACN Table	R	
FIGURE Aircraft Classification Number - ACN Table	R	
Section 7-10	N	
Subject 7-10-0	N	
ACR/PCR Reporting System - Flexible and Rigid Pavements	N	
FIGURE ACR Table	N	ILLUSTRATION ADDED
FIGURE ACR Table	N	ILLUSTRATION ADDED
FIGURE ACR Table	N	ILLUSTRATION ADDED
FIGURE ACR Table	N	ILLUSTRATION ADDED
FIGURE ACR Table	N	ILLUSTRATION ADDED

LIST OF EFFECTIVE CONTENT

Revision No. 30 - Jul 01/21

CONTENT	CHG CODE	LAST REVISION DATE
<u>CHAPTER 1</u>		
Subject 1-1-0		
Introduction		Jul 01/19
Subject 1-2-1		
Glossary		Jan 01/17
<u>CHAPTER 2</u>		
Subject 2-1-1		
General Aircraft Characteristics Data	R	Jul 01/21
General Aircraft Characteristics Data		Jul 01/19
Subject 2-2-0		
General Aircraft Dimensions		Jan 01/17
FIGURE General Aircraft Dimensions		Jul 01/18
FIGURE General Aircraft Dimensions - (Pre Mod 48979)		Jul 01/18
FIGURE General Aircraft Dimensions		Jan 01/17
FIGURE General Aircraft Dimensions		Jan 01/17
General Aircraft Dimensions		Jan 01/17
FIGURE General Aircraft Dimensions		Jan 01/14
Subject 2-3-0		
Ground Clearances	R	Jul 01/21
FIGURE Ground Clearances	R	Jul 01/21
FIGURE Ground Clearances	R	Jul 01/21
FIGURE Ground Clearances	R	Jul 01/21
FIGURE Ground Clearances	R	Jul 01/21
FIGURE Ground Clearances	R	Jul 01/21
FIGURE Ground Clearances - Ailerons – Up	R	Jul 01/21
FIGURE Ground Clearances - Ailerons – Up	R	Jul 01/21

CONTENT	CHG CODE	LAST REVISION DATE
FIGURE Ground Clearances - Ailerons – Down	R	Jul 01/21
FIGURE Ground Clearances - Ailerons – Down	R	Jul 01/21
FIGURE Ground Clearances - Spoilers – Extended	R	Jul 01/21
FIGURE Ground Clearances - Spoilers – Extended	R	Jul 01/21
FIGURE Ground Clearances - Leading Edge Slats – Extended	R	Jul 01/21
FIGURE Ground Clearances - Leading Edge Slats – Extended	R	Jul 01/21
FIGURE Ground Clearances - Trailing Edge Flaps – Extended	R	Jul 01/21
FIGURE Ground Clearances - Trailing Edge Flaps – Extended	R	Jul 01/21
FIGURE Ground Clearances - Flap Tracks – Extended	R	Jul 01/21
FIGURE Ground Clearances - Flap Tracks – Extended	R	Jul 01/21
FIGURE Ground Clearances - Flap Tracks – Retracted	R	Jul 01/21
FIGURE Ground Clearances - Flap Tracks – Retracted	R	Jul 01/21
FIGURE Ground Clearances - Flap Tracks – 1 + F	R	Jul 01/21
FIGURE Ground Clearances - Flap Tracks – 1 + F	R	Jul 01/21
Subject 2-4-1		
Interior Arrangements - Plan View		Jan 01/17
FIGURE Interior Arrangements - Plan View - Typical Configuration		Jan 01/17
FIGURE Interior Arrangements - Plan View - Typical Configuration		Jan 01/17
Subject 2-5-0		
Interior Arrangements - Cross Section		Jan 01/17
FIGURE Interior Arrangements - Cross Section - Typical Configuration		Jan 01/17
Subject 2-6-1		
Lower Deck Cargo Compartments		Jan 01/17
FIGURE Lower Deck Cargo Compartments - Location and Dimensions		Jan 01/17
FIGURE Lower Deck Cargo Compartments - Loading Combinations		Jan 01/17
FIGURE Lower Deck Cargo Compartments - Loading Combinations		Jan 01/17
Subject 2-6-2		
Main Deck Cargo Compartment		Jan 01/14

CONTENT	CHG CODE	LAST REVISION DATE
FIGURE Main Deck Cargo Compartment - Location and Dimensions		Jan 01/14
FIGURE Main Deck Cargo Compartment - Loading Combinations		Jan 01/14
FIGURE Main Deck Cargo Compartment - Loading Combinations		Jan 01/14
FIGURE Main Deck Cargo Compartment - Loading Combinations		Jan 01/14
FIGURE Main Deck Cargo Compartment - Loading Combinations		Jan 01/14
Subject 2-6-3		
Main and Lower Deck Cross-sections		Jan 01/14
FIGURE Main and Lower Deck Cross-sections		Jan 01/14
Subject 2-7-0		
Door Clearances		Jan 01/17
FIGURE Door Clearances - Door Identification		Jul 01/18
FIGURE Door Clearances - Door Identification		Jul 01/18
FIGURE Door Clearances - Door Identification		Jul 01/18
FIGURE Door Clearances - Forward Passenger/Crew Doors		Jan 01/17
FIGURE Door Clearances - Forward Crew Doors		Oct 01/15
FIGURE Door Clearances - Mid Passenger/Crew Doors		Jan 01/17
FIGURE Door Clearances - Emergency Exits		Jan 01/17
FIGURE Door Clearances - Aft Passenger/Crew Doors		Jan 01/17
FIGURE Door Clearances - Forward Cargo Compartment Door		Jan 01/17
FIGURE Door Clearances - Forward Cargo Compartment Door		Oct 01/15
FIGURE Door Clearances - Main Deck Cargo Compartment Door		Jan 01/17
FIGURE Door Clearances - Aft Cargo Compartment Door		Apr 01/20
FIGURE Door Clearances - Aft Cargo Compartment Door		Apr 01/20
FIGURE Door Clearances - Bulk Cargo Compartment Door		Jan 01/17
FIGURE Door Clearances - Bulk Cargo Compartment Door		Oct 01/15
FIGURE Door Clearances - Radome		Jan 01/17
FIGURE Door Clearances - Main Landing Gear Doors		Jan 01/17
FIGURE Door Clearances - Main Landing Gear Doors		Oct 01/15
FIGURE Door Clearances - APU and Nose Landing Gear Doors		Jan 01/17

CONTENT	CHG CODE	LAST REVISION DATE
FIGURE Door Clearances - APU and Nose Landing Gear Doors Subject 2-8-0		Oct 01/15
Escape Slides		Jul 01/18
FIGURE Escape Slides - Location		Jul 01/18
FIGURE Escape Slide - Location		Jul 01/18
FIGURE Escape Slides - Location		Jul 01/18
Subject 2-9-0		
Landing Gear Maintenance Pits		Jan 01/17
FIGURE Landing Gear Maintenance Pits - Maintenance Pit Envelopes		Jul 01/18
FIGURE Landing Gear Maintenance Pits - Maintenance Pit Envelopes		Jan 01/17
Landing Gear		Jan 01/17
FIGURE Main Landing Gear - General		Jan 01/17
FIGURE Nose Landing Gear - General		Jan 01/17
FIGURE Tow Truck Power		Jan 01/17
Subject 2-10-0		
Exterior Lighting		Jan 01/17
FIGURE Exterior Lighting		Jan 01/14
FIGURE Exterior Lighting		Jan 01/14
FIGURE Exterior Lighting		Jan 01/14
FIGURE Exterior Lighting		Jan 01/17
FIGURE Exterior Lighting		Jan 01/17
Subject 2-11-0		
Antennas and Probes Location		Jan 01/17
FIGURE Antennas and Probes - Location		Jan 01/17
FIGURE Antennas and Probes - Location		Jan 01/14
FIGURE Antennas and Probes - Location		Jan 01/17
Subject 2-12-0		
Engine and Nacelle		Jul 01/18
FIGURE Engine and Nacelle - Engine Dimensions - PW 4000		Jan 01/14

CONTENT	CHG CODE	LAST REVISION DATE
FIGURE Engine and Nacelle - Nacelle Dimensions - PW 4000		Jan 01/14
FIGURE Engine and Nacelle - Fan Cowls - PW 4000	R	Jul 01/21
FIGURE Engine and Nacelle - Thrust Reverser Cowls - PW 4000	R	Jul 01/21
FIGURE Engine and Nacelle - Engine Dimensions - TRENT 700		Jan 01/14
FIGURE Engine and Nacelle - Nacelle Dimensions - TRENT 700		Jan 01/14
FIGURE Engine and Nacelle - Fan Cowls - TRENT 700		Jan 01/14
FIGURE Engine and Nacelle - Thrust Reverser Cowls - TRENT 700		Jan 01/14
FIGURE Engine and Nacelle - Engine Dimensions - GE CF6-80E1		Jan 01/14
FIGURE Engine and Nacelle - Nacelle Dimensions - GE CF6-80E1		Jan 01/14
FIGURE Engine and Nacelle - Fan Cowls - GE CF6-80E1		Jan 01/14
FIGURE Engine and Nacelle - Thrust Reverser Cowls - GE CF6-80E1		Jan 01/14
FIGURE Engine and Nacelle - Engine Dimensions - TRENT 7000		Jul 01/18
FIGURE Engine and Nacelle - Nacelle Dimensions - TRENT 7000		Jul 01/18
Subject 2-12-1		
Auxiliary Power Unit		Jan 01/17
FIGURE Auxiliary Power Unit - Access Doors		Jan 01/17
Subject 2-13-0		
Leveling, Symmetry and Alignment		Jan 01/17
FIGURE Location of Leveling Points		Jan 01/17
FIGURE Location of Leveling Points		Jan 01/17
FIGURE Location of Leveling Points		Jan 01/14
Subject 2-14-0		
Jacking for Maintenance		Jan 01/17
FIGURE Jacking for Maintenance - Jacking Points Location	R	Jul 01/21
FIGURE Jacking for Maintenance - Jacking Points Location	R	Jul 01/21
FIGURE Jacking for Maintenance - Jacking Points Location	R	Jul 01/21
FIGURE Jacking for Maintenance - Jacking Points Location	R	Jul 01/21
FIGURE Jacking for Maintenance - Jacking Points Location	R	Jul 01/21
FIGURE Jacking for Maintenance - Forward Jacking Point		Jan 01/17

CONTENT	CHG CODE	LAST REVISION DATE
FIGURE Jacking for Maintenance - Forward Jacking Point		Jan 01/14
FIGURE Jacking for Maintenance - Wing Jacking Points		Jan 01/17
FIGURE Jacking for Maintenance - Wing Jacking Points		Jan 01/14
FIGURE Jacking for Maintenance - Auxiliary Jacking Point - Safety Stay		Jan 01/17
FIGURE Jacking for Maintenance - Auxiliary Jacking Point - Safety Stay		Jan 01/14
FIGURE Jacking for Maintenance - Auxiliary Jacking Point - Safety Stay		Jan 01/14
FIGURE Jacking for Maintenance - Specific Jack-Nose Dimensions		Jan 01/14
FIGURE Jacking for Maintenance - Jacking Dimensions	R	Jul 01/21
FIGURE Jacking for Maintenance - Jacking Dimensions	R	Jul 01/21
FIGURE Jacking for Maintenance - Jacking Dimensions	R	Jul 01/21
FIGURE Jacking for Maintenance - Jacking Dimensions	R	Jul 01/21
FIGURE Jacking for Maintenance - Jacking Dimensions	R	Jul 01/21
Subject 2-14-1		
Jacking of the Landing Gear		Jan 01/17
FIGURE Jacking of the Landing Gear - MLG Jacking Point Heights		Jul 01/18
FIGURE Jacking of the Landing Gear - Jacking of the NLG		Jan 01/17
FIGURE Jacking of the Landing Gear - Maximum Load at Each Jacking Point		Jan 01/17
FIGURE Jacking of the Landing Gear - Maximum Load at Each Jacking Point		Jan 01/17
FIGURE Jacking of the Landing Gear - Maximum Load at Each Jacking Point		Jul 01/18
FIGURE Jacking of the Landing Gear - Maximum Load at Each Jacking Point		Jul 01/18
Subject 2-14-2		
Support of Aircraft		Jan 01/17
FIGURE Support of Aircraft - Location of Shoring Cradles		Jan 01/17
FIGURE Support of Aircraft - Location of Shoring Cradles		Jan 01/17

CONTENT	CHG CODE	LAST REVISION DATE
FIGURE Support of Aircraft - Location of Shoring Cradles		Jan 01/14
<u>CHAPTER 3</u>		
Subject 3-1-0		
General Information		Jul 01/18
Subject 3-2-1		
Payload / Range - ISA Conditions		Jun 01/20
FIGURE Payload / Range - ISA Conditions - PW 4000 Series Engine		Jul 01/19
FIGURE Payload / Range - ISA Conditions - RR TRENT 700 Series Engine		Jul 01/19
FIGURE Payload / Range - ISA Conditions - GE CF6-80E1 Series Engine		Jul 01/19
FIGURE Payload / Range - ISA Conditions - RR TRENT 700 Series Engine		Jul 01/19
FIGURE Payload / Range - ISA Conditions - PW 4000 Series Engine		Jul 01/19
FIGURE Payload / Range - ISA Conditions - PW 4000 Series Engine		Jul 01/19
FIGURE Payload / Range - ISA Conditions - RR TRENT 700 Series Engine		Jul 01/19
FIGURE Payload / Range - ISA Conditions - GE CF6-80E1 Series Engine		Jul 01/19
FIGURE Payload / Range - ISA Conditions - RR TRENT 7000 Series Engine		Jun 01/20
Subject 3-3-1		
Take-Off Weight Limitation - ISA Conditions		Jun 01/20
FIGURE Take-Off Weight Limitation - ISA Conditions - PW 4000 Series Engine		Jun 01/20
FIGURE Take-Off Weight Limitation - ISA Conditions - RR TRENT 700 Series Engine		Jun 01/20
FIGURE Take-Off Weight Limitation - ISA Conditions - GE CF6-80E1 Series Engine		Jun 01/20
FIGURE Take-Off Weight Limitation - ISA Conditions - PW 4000 Series Engine		Jun 01/20

CONTENT	CHG CODE	LAST REVISION DATE
FIGURE Take-Off Weight Limitation - ISA Conditions - RR TRENT 700 Series Engine		Jun 01/20
FIGURE Take-Off Weight Limitation - ISA Conditions - PW 4000 Series Engine		Jun 01/20
FIGURE Take-Off Weight Limitation - ISA Conditions - RR TRENT 700 Series Engine		Jun 01/20
FIGURE Take-Off Weight Limitation - ISA Conditions - GE CF6-80E1 Series Engine		Jun 01/20
FIGURE Take-Off Weight Limitation - ISA Conditions - RR TRENT 7000 Series Engine		Jun 01/20
Subject 3-3-2		
Take-Off Weight Limitation - ISA +15 ° C (+27 ° F) Conditions		Jun 01/20
FIGURE Take-Off Weight Limitation - ISA +15 ° C (+27 ° F) Conditions - PW 4000 Series Engine		Jun 01/20
FIGURE Take-Off Weight Limitation - ISA +15 ° C (+27 ° F) Conditions - RR TRENT 700 Series Engine		Jun 01/20
FIGURE Take-Off Weight Limitation - ISA +15 ° C (+27 ° F) Conditions - GE CF6-80E1 Series Engine		Jun 01/20
FIGURE Take-Off Weight Limitation - ISA +15 ° C (+27 ° F) Conditions - PW 4000 Series Engine		Jun 01/20
FIGURE Take-Off Weight Limitation - ISA +15 ° C (+27 ° F) Conditions - RR TRENT 700 Series Engine		Jun 01/20
FIGURE Take-Off Weight Limitation - ISA +15 ° C (+27 ° F) Conditions - PW 4000 Series Engine		Jun 01/20
FIGURE Take-Off Weight Limitation - ISA +15 ° C (+27 ° F) Conditions - RR TRENT 700 Series Engine		Jun 01/20
FIGURE Take-Off Weight Limitation - ISA +15 ° C (+27 ° F) Conditions - GE CF6-80E1 Series Engine		Jun 01/20
FIGURE Take-Off Weight Limitation - ISA +15 ° C (+27 ° F) Conditions - RR TRENT 7000 Series Engine		Jun 01/20
Subject 3-3-3		
Aerodrome Reference Code		Apr 01/20
Subject 3-4-1		

CONTENT	CHG CODE	LAST REVISION DATE
Landing Field Length - ISA Conditions		Jun 01/20
FIGURE Landing Field Length - ISA Conditions - PW 4000 Series Engine		Jun 01/20
FIGURE Landing Field Length - ISA Conditions - RR TRENT 700 Series Engine		Jun 01/20
FIGURE Landing Field Length - ISA Conditions - GE CF6-80E1 Series Engine		Jun 01/20
FIGURE Landing Field Length - ISA Conditions - PW 4000 Series Engine		Jun 01/20
FIGURE Landing Field Length - ISA Conditions - RR TRENT 700 Series Engine		Jun 01/20
FIGURE Landing Field Length - ISA Conditions - PW 4000 Series Engine		Jun 01/20
FIGURE Landing Field Length - ISA Conditions - RR TRENT 700 Series Engine		Jun 01/20
FIGURE Landing Field Length - ISA Conditions - GE CF6-80E1 Series Engine		Jun 01/20
FIGURE Landing Field Length - ISA Conditions - RR TRENT 7000 Series Engine		Jun 01/20
Subject 3-5-0		
Final Approach Speed		Apr 01/20
<u>CHAPTER 4</u>		
Subject 4-1-0		
General Information	R	Jul 01/21
Subject 4-2-0		
Turning Radii	R	Jul 01/21
FIGURE Turning Radii - (Sheet 1)	R	Jul 01/21
FIGURE Turning Radii - (Sheet 2)	R	Jul 01/21
FIGURE Turning Radii - (Sheet 2)	R	Jul 01/21
FIGURE Turning Radii - (Sheet 1)	R	Jul 01/21
FIGURE Turning Radii - (Sheet 2)	R	Jul 01/21

CONTENT	CHG CODE	LAST REVISION DATE
FIGURE Turning Radii - (Sheet 2) Subject 4-3-0	R	Jul 01/21
Minimum Turning Radii	R	Jul 01/21
FIGURE Minimum Turning Radii		Jan 01/17
FIGURE Minimum Turning Radii		Jan 01/14
FIGURE Minimum Turning Radii	R	Jul 01/21
FIGURE Minimum Turning Radii	R	Jul 01/21
Subject 4-4-0		
Visibility from Cockpit in Static Position.		Jul 01/19
FIGURE Visibility from Cockpit in Static Position		Jul 01/19
FIGURE Visibility from Cockpit in Static Position		Jul 01/19
FIGURE Binocular Visibility Through Windows from Captain Eye Position		Jan 01/17
Subject 4-5-0		
Runway and Taxiway Turn Paths	R	Jul 01/21
Subject 4-5-1		
135° Turn - Runway to Taxiway		Jan 01/17
FIGURE 135° Turn - Runway to Taxiway - Judgemental Oversteering Method	R	Jul 01/21
FIGURE 135° Turn - Runway to Taxiway - Cockpit Over Centerline Method	R	Jul 01/21
FIGURE 135° Turn - Runway to Taxiway - Judgemental Oversteering Method	R	Jul 01/21
FIGURE 135° Turn - Runway to Taxiway - Cockpit Over Centerline Method	R	Jul 01/21
Subject 4-5-2		
90° Turn - Runway to Taxiway		Jan 01/17
FIGURE 90° Turn - Runway to Taxiway - Judgemental Oversteering Method	R	Jul 01/21
FIGURE 90° Turn - Runway to Taxiway - Cockpit Over Centerline Method	R	Jul 01/21

CONTENT	CHG CODE	LAST REVISION DATE
FIGURE 90° Turn - Runway to Taxiway - Judgemental Oversteering Method	R	Jul 01/21
FIGURE 90° Turn - Runway to Taxiway - Cockpit Over Centerline Method	R	Jul 01/21
Subject 4-5-3		
180° Turn on a Runway	R	Jul 01/21
FIGURE 180° Turn on a Runway	R	Jul 01/21
FIGURE 180° Turn on a Runway	R	Jul 01/21
FIGURE 180° Turn on a Runway	R	Jul 01/21
FIGURE 180° Turn on a Runway	R	Jul 01/21
Subject 4-5-4		
135° Turn - Taxiway to Taxiway		Jan 01/17
FIGURE 135° Turn - Taxiway to Taxiway - Judgemental Oversteering Method	R	Jul 01/21
FIGURE 135° Turn - Taxiway to Taxiway - Cockpit Over Centerline Method	R	Jul 01/21
FIGURE 135° Turn - Taxiway to Taxiway - Judgemental Oversteering Method	R	Jul 01/21
FIGURE 135° Turn - Taxiway to Taxiway - Cockpit Over Centerline Method	R	Jul 01/21
Subject 4-5-5		
90° Turn - Taxiway to Taxiway		Jan 01/17
FIGURE 90° Turn - Taxiway to Taxiway - Judgemental Oversteering Method	R	Jul 01/21
FIGURE 90° Turn - Taxiway to Taxiway - Cockpit Over Centerline Method	R	Jul 01/21
FIGURE 90° Turn - Taxiway to Taxiway - Judgemental Oversteering Method	R	Jul 01/21
FIGURE 90° Turn - Taxiway to Taxiway - Cockpit Over Centerline Method	R	Jul 01/21
Subject 4-6-0		
Runway Holding Bay (Apron)		Jan 01/17
FIGURE Runway Holding Bay (Apron)		Oct 01/15

CONTENT	CHG CODE	LAST REVISION DATE
FIGURE Runway Holding Bay (Apron)		Jan 01/17
Subject 4-7-0		
Minimum Line-Up Distance Corrections	R	Jul 01/21
FIGURE Minimum Line-Up Distance Corrections - 90° Turn on Runway Entry	R	Jul 01/21
FIGURE Minimum Line-Up Distance Corrections - 180° Turn on Runway Turn Pad	R	Jul 01/21
FIGURE Minimum Line-Up Distance Corrections - 180° Turn on Runway Width	R	Jul 01/21
Subject 4-8-0		
Aircraft Mooring		Jan 01/17
FIGURE Aircraft Mooring		Jan 01/17
<u>CHAPTER 5</u>		
Subject 5-1-0		
Aircraft Servicing Arrangements		Jan 01/17
Subject 5-1-1		
Symbols Used on Servicing Diagrams		Jan 01/17
Subject 5-1-2		
Typical Ramp Layout - Open Apron		Jan 01/17
FIGURE Typical Ramp Layout - Open Apron		Jan 01/17
FIGURE Typical Ramp Layout - Open Apron		Jan 01/17
Typical Ramp Layout - Open Apron		Jan 01/17
FIGURE Typical Ramp Layout - Open Apron		Jan 01/14
Subject 5-1-3		
Typical Ramp Layout - Gate		Jan 01/17
FIGURE Typical Ramp Layout - Gate		Jan 01/17
FIGURE Typical Ramp Layout - Gate		Jan 01/17
Subject 5-2-0		
Terminal Operations – Full Servicing Turn Round Time		Jul 01/18
FIGURE Full Servicing Turn Round Time Chart		Jul 01/18

CONTENT	CHG CODE	LAST REVISION DATE
Terminal Operations – Full Servicing Turn Round Time		Jul 01/18
FIGURE Full Servicing Turn Round Time Chart		Jul 01/18
Terminal Operations - Full Servicing Turn Round Time		Jul 01/19
FIGURE Full Servicing Turn Round Time Chart		Jul 01/19
Subject 5-3-0		
Terminal Operations - Transit Turn Round Time		Jul 01/18
FIGURE Transit Turn Round Time Chart		Jul 01/18
Terminal Operations - Transit Turn Round Time		Jul 01/18
FIGURE Transit Turn Round Time Chart		Jul 01/18
Subject 5-4-1		
Ground Service Connections Layout	R	Jul 01/21
FIGURE Ground Service-Connections Layout	R	Jul 01/21
FIGURE Ground Service-Connections Layout	N	Jul 01/21
Ground Service Connections Layout		Oct 01/15
FIGURE Ground Service Connections Layout		Oct 01/15
Subject 5-4-2		
Grounding (Earthing) Points		Jul 01/18
FIGURE Ground Service Connections - Grounding (Earthing) Points		Jan 01/17
FIGURE Ground Service Connections - Grounding (Earthing) Points		Jan 01/17
Subject 5-4-3		
Hydraulic Servicing		Jul 01/18
FIGURE Ground Service Connections - Green System Ground Service Panel		Jan 01/17
FIGURE Ground Service Connections - Blue System Ground Service Panel		Jan 01/17
FIGURE Ground Service Connections - Yellow System Ground Service Panel		Jan 01/17
FIGURE Ground Service Connections - RAT		Jan 01/17
Subject 5-4-4		
Electrical Servicing		Jul 01/18

CONTENT	CHG CODE	LAST REVISION DATE
FIGURE Ground Service Connections - Electrical Service Panel		Jan 01/17
FIGURE Ground Service Connections - Electrical Service Panel		Oct 01/15
Subject 5-4-5		
Oxygen Servicing		Jul 01/18
FIGURE Ground Service Connections - Oxygen Servicing		Jan 01/17
FIGURE Ground Service Connections - Oxygen Servicing		Oct 01/15
Subject 5-4-6		
Fuel System		Jul 01/18
FIGURE Ground Service Connections - Refuel/Defuel Control Panel		Jan 01/17
FIGURE Ground Service Connections - Refuel/Defuel Coupling		Jan 01/17
FIGURE Ground Service Connections - Overpressure Protector and NACA Flame Arrestor - Wing		Jan 01/17
FIGURE Ground Service Connections - Overpressure Protector and NACA Flame Arrestor - Trim Tank		Jan 01/17
Subject 5-4-7		
Pneumatic Servicing		Jul 01/18
FIGURE Ground Service Connections - LP and HP Ground Connectors		Jan 01/17
Subject 5-4-8		
Oil Servicing		Jul 01/18
FIGURE Ground Service Connections - Engine Oil Tank - PW 4000 Series Engine		Oct 01/15
FIGURE Ground Service Connections - IDG Oil Tank - PW 4000 Series Engine		Oct 01/15
FIGURE Ground Service Connections - Starter Oil Tank - PW 4000 Series Engine		Oct 01/15
FIGURE Ground Service Connections - Engine Oil Tank - RR Trent 700 Series Engine		Oct 01/15
FIGURE Ground Service Connections - IDG Oil Tank - RR Trent 700 Series Engine		Oct 01/15
FIGURE Ground Service Connections - Starter Oil Tank - RR Trent 700 Series Engine		Oct 01/15

CONTENT	CHG CODE	LAST REVISION DATE
FIGURE Ground Service Connections - Engine Oil Tank - GE CF6-80E1 Series Engine		Oct 01/15
FIGURE Ground Service Connections - IDG Oil Tank - GE CF6-80E1 Series Engine		Oct 01/15
FIGURE Ground Service Connections - Starter Oil Tank - GE CF6-80E1 Series Engine		Oct 01/15
APU Oil Servicing		Jul 01/18
FIGURE Ground Service Connections - APU Oil Servicing		Jan 01/17
Subject 5-4-9		
Potable Water Servicing	R	Jul 01/21
FIGURE Ground Service Connections - Potable-Water Ground Service Panels		Jan 01/17
FIGURE Ground Service Connections - Potable-Water Tanks Location Potable Water Servicing	R	Jul 01/21
FIGURE Ground Service Connections - Potable-Water Ground Service Panels		Jan 01/17
FIGURE Ground Service Connections - Potable-Water Tanks Location Potable Water Servicing	R	Jul 01/21
FIGURE Ground Service Connections - Potable-Water Ground Service Panel		Oct 01/15
FIGURE Ground Service Connections - Potable-Water Tank Location		Oct 01/15
Subject 5-4-10		
Waste Water Servicing		Jul 01/18
FIGURE Ground Service Connections - Waste Water Ground Service Panel		Jan 01/17
FIGURE Ground Service Connections - Waste Water Ground Service Panel		Jan 01/14
FIGURE Ground Service Connections - Waste Tanks Location		Jan 01/17
Subject 5-4-11		
Cargo Control Panels		Jul 01/18
FIGURE Forward Cargo Control Panels		Jan 01/17
FIGURE Aft Cargo Control Panels		Jan 01/17

CONTENT	CHG CODE	LAST REVISION DATE
FIGURE Main Deck Cargo Control Panel		Oct 01/15
Subject 5-5-0		
Engine Starting Pneumatic Requirements	R	Jul 01/21
Subject 5-6-0		
Ground Pneumatic Power Requirements		Jan 01/17
FIGURE Ground Pneumatic Power Requirements - Heating		Jan 01/17
FIGURE Ground Pneumatic Power Requirements - Cooling		Jan 01/17
Subject 5-7-0		
Preconditioned Airflow Requirements		Jan 01/17
FIGURE Preconditioned Airflow Requirements		Jan 01/17
Subject 5-8-0		
Ground Towing Requirements		Jul 01/18
FIGURE Ground Towing Requirements		Jul 01/19
FIGURE Ground Towing Requirements		Jul 01/18
Subject 5-9-0		
De-Icing and External Cleaning		Jan 01/17
<u>CHAPTER 6</u>		
Subject 6-1-0		
Engine Exhaust Velocities and Temperatures		Jul 01/18
Subject 6-1-1		
Engine Exhaust Velocities Contours - Ground Idle Power		Aug 01/19
FIGURE Engine Exhaust Velocities - Ground Idle Power - PW 4000 series engine		Jan 01/14
FIGURE Engine Exhaust Velocities - Ground Idle Power - RR Trent 700 series engine		Jan 01/14
FIGURE Engine Exhaust Velocities - Ground Idle Power - GE CF6-80E1 series engine		Jan 01/14
FIGURE Engine Exhaust Velocities - Ground Idle Power - RR Trent 7000 series engine		Aug 01/19
Subject 6-1-2		

CONTENT	CHG CODE	LAST REVISION DATE
Engine Exhaust Temperatures Contours - Ground Idle Power		Aug 01/19
FIGURE Engine Exhaust Temperatures - Ground Idle Power - PW 4000 series engine		Jan 01/14
FIGURE Engine Exhaust Temperatures - Ground Idle Power - RR Trent 700 series engine		Jan 01/14
FIGURE Engine Exhaust Temperatures - Ground Idle Power - GE CF6-80E1 series engine		Jan 01/14
FIGURE Engine Exhaust Temperatures - Ground Idle Power - RR Trent 7000 series engine		Aug 01/19
Subject 6-1-3		
Engine Exhaust Velocities Contours - Breakaway Power		Aug 01/19
FIGURE Engine Exhaust Velocities - Breakaway Power - PW 4000 series engine		Jan 01/14
FIGURE Engine Exhaust Velocities - Breakaway Power - RR Trent 700 series engine		Jan 01/14
FIGURE Engine Exhaust Velocities - Breakaway Power - GE CF6-80E1 series engine		Jan 01/14
FIGURE Engine Exhaust Velocities - Breakaway Power (14% MTO Thrust) - RR Trent 7000 series engine		Aug 01/19
FIGURE Engine Exhaust Velocities - Breakaway Power (28% MTO Thrust) - RR Trent 7000 series engine		Aug 01/19
Subject 6-1-4		
Engine Exhaust Temperatures Contours - Breakaway Power		Aug 01/19
FIGURE Engine Exhaust Temperatures - Breakaway Power - PW 4000 series engine		Jan 01/14
FIGURE Engine Exhaust Temperatures - Breakaway Power - RR Trent 700 series engine		Jan 01/14
FIGURE Engine Exhaust Temperatures - Breakaway Power - GE CF6-80E1 series engine		Jan 01/14
FIGURE Engine Exhaust Temperatures - Breakaway Power (14% MTO Thrust) - RR Trent 7000 series engine		Aug 01/19
FIGURE Engine Exhaust Temperatures - Breakaway Power (28% MTO Thrust) - RR Trent 7000 series engine		Aug 01/19

CONTENT	CHG CODE	LAST REVISION DATE
<p>Subject 6-1-5</p> <p>Engine Exhaust Velocities Contours - Takeoff Power</p> <p>FIGURE Engine Exhaust Velocities - Takeoff Power - PW 4000 series engine</p> <p>FIGURE Engine Exhaust Velocities - Takeoff Power - RR Trent 700 series engine</p> <p>FIGURE Engine Exhaust Velocities - Takeoff Power - GE CF6-80E1 series engine</p> <p>FIGURE Engine Exhaust Velocities - Takeoff Power - RR Trent 7000 series engine</p>		<p>Aug 01/19</p> <p>Jan 01/14</p> <p>Jan 01/14</p> <p>Jan 01/14</p> <p>Aug 01/19</p>
<p>Subject 6-1-6</p> <p>Engine Exhaust Temperatures Contours - Takeoff Power</p> <p>FIGURE Engine Exhaust Temperatures - Takeoff Power - PW 4000 series engine</p> <p>FIGURE Engine Exhaust Temperatures - Takeoff Power - RR Trent 700 series engine</p> <p>FIGURE Engine Exhaust Temperatures - Takeoff Power - GE CF6-80E1 series engine</p> <p>FIGURE Engine Exhaust Temperatures - Takeoff Power - RR Trent 7000 series engine</p>		<p>Aug 01/19</p> <p>Jan 01/14</p> <p>Jan 01/14</p> <p>Jan 01/14</p> <p>Aug 01/19</p>
<p>Subject 6-3-0</p> <p>Danger Areas of Engines</p>		<p>Aug 01/19</p>
<p>Subject 6-3-1</p> <p>Ground Idle Power</p> <p>FIGURE Danger Areas of Engines - PW 4000 Series Engine</p> <p>FIGURE Danger Areas of Engines - RR Trent 700 Series Engine</p> <p>FIGURE Danger Areas of Engines - GE CF6-80E1 Series Engine</p> <p>FIGURE Danger Areas of Engines - RR Trent 7000 Series Engine</p>		<p>Aug 01/19</p> <p>Oct 01/15</p> <p>Aug 01/19</p> <p>Oct 01/15</p> <p>Aug 01/19</p>
<p>Subject 6-3-2</p> <p>Breakaway Power</p> <p>FIGURE Danger Areas of Engines - PW 4000 Series Engine</p>		<p>Aug 01/19</p> <p>Aug 01/19</p>

CONTENT	CHG CODE	LAST REVISION DATE
FIGURE Danger Areas of Engines - RR Trent 700 Series Engine		Aug 01/19
FIGURE Danger Areas of Engines - GE CF6-80E1 Series Engine		Oct 01/15
FIGURE Danger Areas of Engines - RR Trent 7000 Series Engine		Aug 01/19
Subject 6-3-3		
Takeoff Power		Aug 01/19
FIGURE Danger Areas of Engines - PW 4000 Series Engine		Oct 01/15
FIGURE Danger Areas of Engines - RR Trent 700 Series Engine		Aug 01/19
FIGURE Danger Areas of Engines - GE CF6-80E1 Series Engine		Oct 01/15
FIGURE Danger Areas of Engines - RR Trent 7000 Series Engine		Aug 01/19
Subject 6-4-0		
APU Exhaust Velocities and Temperatures		Jul 01/18
Subject 6-4-1		
APU - GARRETT		Jul 01/18
FIGURE Exhaust Velocities and Temperatures - APU – GARRETT GTCP 331-350		Jul 01/18
<u>CHAPTER 7</u>		
Subject 7-1-0		
General Information	R	Jul 01/21
Subject 7-2-0		
Landing Gear Footprint	R	Jul 01/21
FIGURE Landing Gear Footprint	R	Jul 01/21
FIGURE Landing Gear Footprint	R	Jul 01/21
FIGURE Landing Gear Footprint	R	Jul 01/21
FIGURE Landing Gear Footprint	R	Jul 01/21
FIGURE Landing Gear Footprint	R	Jul 01/21
Subject 7-3-0		
Maximum Pavement Loads	R	Jul 01/21
FIGURE Maximum Pavement Loads	R	Jul 01/21
FIGURE Maximum Pavement Loads	R	Jul 01/21

CONTENT	CHG CODE	LAST REVISION DATE
FIGURE Maximum Pavement Loads	R	Jul 01/21
FIGURE Maximum Pavement Loads	R	Jul 01/21
FIGURE Maximum Pavement Loads	R	Jul 01/21
Subject 7-4-0		
Landing Gear Loading on Pavement	R	Jul 01/21
Subject 7-5-0		
Flexible Pavement Requirements - US Army Corps of Engineers Design Method	R	Jul 01/21
Subject 7-6-0		
Flexible Pavement Requirements - LCN Conversion	R	Jul 01/21
Subject 7-7-0		
Rigid Pavement Requirements - Portland Cement Association Design Method	R	Jul 01/21
Subject 7-8-0		
Rigid Pavement Requirements - LCN Conversion	R	Jul 01/21
Subject 7-9-0		
Aircraft Classification Number - Flexible and Rigid Pavements	R	Jul 01/21
FIGURE Aircraft Classification Number - ACN Table	R	Jul 01/21
FIGURE Aircraft Classification Number - ACN Table		Jan 01/14
FIGURE Aircraft Classification Number - ACN Table	R	Jul 01/21
FIGURE Aircraft Classification Number - ACN Table	R	Jul 01/21
FIGURE Aircraft Classification Number - ACN Table	R	Jul 01/21
Subject 7-10-0		
ACR/PCR Reporting System - Flexible and Rigid Pavements	N	Jul 01/21
FIGURE ACR Table	N	Jul 01/21
FIGURE ACR Table	N	Jul 01/21
FIGURE ACR Table	N	Jul 01/21
FIGURE ACR Table	N	Jul 01/21
FIGURE ACR Table	N	Jul 01/21

CONTENT	CHG CODE	LAST REVISION DATE
<u>CHAPTER 8</u>		
Subject 8-0-0		
Scaled Drawings		Jan 01/17
FIGURE Scaled Drawing		Jan 01/17
FIGURE Scaled Drawing		Jan 01/17
FIGURE Scaled Drawing		Jan 01/17
FIGURE Scaled Drawing		Jan 01/17
FIGURE Scaled Drawing		Jan 01/17
<u>CHAPTER 10</u>		
Subject 10-0-0		
Aircraft Rescue and Fire Fighting		Oct 01/15
FIGURE Front Page		Jul 01/18
FIGURE Highly Flammable and Hazardous Materials and Components		Oct 01/15
FIGURE Batteries Location and Access		Oct 01/15
FIGURE Crew Rest Compartments Location		Jan 01/14
FIGURE Wheel/Brake Overheat - Wheel Safety Area		Jan 01/14
FIGURE Composite Materials Location		Jan 01/17
FIGURE Ground Lock Safety Devices		Jan 01/14
FIGURE Emergency Evacuation Devices		Jul 01/18
FIGURE Pax/Crew Doors and Emergency Exits		Jan 01/14
FIGURE FWD and AFT Lower Deck Cargo Doors		Jan 01/14
FIGURE Control Panels		Jan 01/14
FIGURE APU Compartment Access		Jan 01/14
FIGURE Ground Clearances		Jan 01/17
FIGURE Structural Break-in Points		Jan 01/14
Aircraft Rescue and Fire Fighting		Oct 01/15
FIGURE Front Page		Jul 01/18
FIGURE Highly Flammable and Hazardous Materials and Components		Oct 01/15
FIGURE Batteries Location and Access		Oct 01/15

CONTENT	CHG CODE	LAST REVISION DATE
FIGURE Wheel/Brake Overheat - Wheel Safety Area		Jan 01/14
FIGURE Composite Materials Location		Jan 01/17
FIGURE Ground Lock Safety Devices		Jan 01/14
FIGURE Emergency Evacuation Devices		Jul 01/18
FIGURE Crew Doors and Emergency Exits		Jan 01/14
FIGURE Cargo Doors - FWD and AFT Lower Deck Compartments		Jan 01/14
FIGURE Control Panels		Jan 01/14
FIGURE APU Compartment Access		Jan 01/14
FIGURE Ground Clearances		Jan 01/17
FIGURE Structural Break-in Points		Oct 01/15
Aircraft Rescue and Fire Fighting		Jan 01/17
FIGURE Front Page		Jul 01/18
FIGURE Highly Flammable and Hazardous Materials and Components		Jan 01/17
FIGURE Batteries Location and Access		Jan 01/17
FIGURE Crew Rest Compartments Location		Jan 01/17
FIGURE Wheel/Brake Overheat - Wheel Safety Area		Jan 01/17
FIGURE Composite Materials Location		Jan 01/17
FIGURE Ground Lock Safety Devices		Jan 01/17
FIGURE Emergency Evacuation Devices		Jul 01/18
FIGURE Pax/Crew Doors and Emergency Exits		Jan 01/17
FIGURE FWD and AFT Lower Deck Cargo Doors		Jan 01/17
FIGURE Control Panels		Jan 01/17
FIGURE APU Compartment Access		Jan 01/17
FIGURE Ground Clearances		Jan 01/17
FIGURE Structural Break-in Points		Jan 01/17

TABLE OF CONTENTS

1	SCOPE
1-1-0	Purpose
1-2-1	Glossary
2	AIRCRAFT DESCRIPTION
2-1-1	General Aircraft Characteristics Data
2-2-0	General Aircraft Dimensions
2-3-0	Ground Clearances
2-4-1	Interior Arrangements - Plan View
2-5-0	Interior Arrangements - Cross Section
2-6-1	Lower Deck Cargo Compartments
2-6-2	Main Deck Cargo Compartments
2-6-3	Main and Lower Deck Cross-sections
2-7-0	Door Clearances
2-8-0	Escape Slides
2-9-0	Landing Gear
2-10-0	Exterior Lighting
2-11-0	Antennas and Probes Location
2-12-0	Engine and Nacelle
2-12-1	Auxiliary Power Unit
2-13-0	Levelling, symmetry and Alignment
2-14-0	Jacking for Maintenance
2-14-1	Jacking of the Landing Gear
2-14-2	Support of Aircraft
3	AIRCRAFT PERFORMANCE
3-1-0	General Information
3-2-1	Payload / Range - ISA Conditions
3-3-1	Take-Off Weight Limitation - ISA Conditions
3-3-2	Take-Off Weight Limitation - ISA +15 ° C (+59 ° F) Conditions
3-3-3	Aerodrome Reference Code
3-4-1	Landing Field Length - ISA Conditions
3-5-0	Final Approach Speed
4	GROUND MANEUVERING

4-1-0	General Information
4-2-0	Turning Radii
4-3-0	Minimum Turning Radii
4-4-0	Visibility from Cockpit in Static Position
4-5-0	Runway and Taxiway Turn Paths
4-5-1	135° Turn - Runway to Taxiway
4-5-2	90° Turn - Runway to Taxiway
4-5-3	180° Turn on a Runway
4-5-4	135° Turn - Taxiway to Taxiway
4-5-5	90° Turn - Taxiway to Taxiway
4-6-0	Runway Holding Bay (Apron)
4-7-0	Minimum Line-Up Distance Corrections
4-8-0	Aircraft Mooring
5	TERMINAL SERVICING
5-1-0	Aircraft Servicing Arrangements
5-1-1	Symbols Used on Servicing Diagrams
5-1-2	Typical Ramp Layout - Open Apron
5-1-3	Typical Ramp Layout - Gate
5-2-0	Terminal Operations - Full Servicing
5-3-0	Terminal Operations - Transit
5-4-1	Ground Service Connections Layout
5-4-2	Grounding Points
5-4-3	Hydraulic System
5-4-4	Electrical System
5-4-5	Oxygen System
5-4-6	Fuel System
5-4-7	Pneumatic System
5-4-8	Oil System
5-4-9	Potable Water System
5-4-10	Waste Water System
5-4-11	Cargo Control Panels
5-5-0	Engine Starting Pneumatic Requirements
5-6-0	Ground Pneumatic Power Requirements
5-7-0	Preconditioned Airflow Requirements
5-8-0	Ground Towing Requirements
5-9-0	De-Icing and External Cleaning

6	OPERATING CONDITIONS
6-1-0	Engine Exhaust Velocities and Temperatures
6-1-1	Engine Exhaust Velocities Contours - Ground Idle Power
6-1-2	Engine Exhaust Temperatures Contours - Ground Idle Power
6-1-3	Engine Exhaust Velocities Contours - Breakaway Power
6-1-4	Engine Exhaust Temperatures Contours - Breakaway Power
6-1-5	Engine Exhaust Velocities Contours - Takeoff Power
6-1-6	Engine Exhaust Temperatures Contours - Takeoff Power
6-3-0	Danger Areas of Engines
6-3-1	Ground Idle Power
6-3-2	Breakaway Power
6-3-3	Takeoff Power
6-4-0	APU Exhaust Velocities and Temperatures
6-4-1	APU
7	PAVEMENT DATA
7-1-0	General Information
7-2-0	Landing Gear Footprint
7-3-0	Maximum Pavement Loads
7-4-0	Landing Gear Loading on Pavement
7-5-0	Flexible Pavement Requirements - U.S. Army Corps of Engineers Design Method
7-6-0	Flexible Pavement Requirements - LCN Conversion
7-7-0	Rigid Pavement Requirements - Portland Cement Association Design Method
7-8-0	Rigid Pavement Requirements - LCN Conversion
7-9-0	ACN/PCN Reporting System - Flexible and Rigid Pavements
7-10-0	ACR/PCR Reporting System - Flexible And Rigid Pavement
8	SCALED DRAWINGS
8-0-0	SCALED DRAWINGS
10	AIRCRAFT RESCUE AND FIRE FIGHTING
10-0-0	AIRCRAFT RESCUE AND FIRE FIGHTING

SCOPE

1-1-0 Purpose

****ON A/C A330-200 A330-200F A330-300 A330-800 A330-900**

Introduction

1. General

The A330 AIRCRAFT CHARACTERISTICS - AIRPORT AND MAINTENANCE PLANNING (AC) manual is issued for the A330-200, A330-200F, A330-300, A330-800 and A330-900 basic versions to give necessary data to airport operators, airlines and Maintenance/Repair Organizations (MRO) for airport and maintenance facilities planning.

This document is not customized and must not be used for training purposes.

The A330 Family – with Passenger, Freighter, VIP and Military Transport/Tanker variants - is one of the most widely-used, versatile and economic wide-bodies in service and has more than 120 operators flying to over 400 airports worldwide.

The latest member of the A330 family is the A330neo, incorporating the latest-generation Rolls-Royce Trent 7000 engines and powerplant system along with a new wing, new sharklet wingtip devices and a new airspace designed by Airbus interiors. These latest technologies deliver new generation fuel burn (14 percent per seat lower than the A330) and new generation economics combined with the versatility and reliability of the A330. Most recently, the MTOW of both the A330-800 and A330-900 has been increased by 9 000 kg (19 842 lb) to 251 000 kg (553 360 lb) giving over 600 nm (1 111 km) more range than the 242 000 kg (533 519 lb) version and typically up to 1 500 nm (2 778 km) more than current generation A330s.

The A330-800 and A330-900 along with the A330-200 and A330-300 offer several payload capabilities, ranging from 200 passengers in a high-comfort multi-class layout up to 440 passengers in a high efficiency configuration. The NEO two versions, A330-800NEO and A330-900NEO, share the same fuselage length as today A330-200 and A330-300 current engine option jetliners respectively. The new generation mid-size freighter, the A330-200F, has up to 70 000 kg (154 324 lb) payload and a range of up to 4 000 nm (7 408 km). It offers better payload, range and economics than previous generation freighters.

The ACJ330 offers true space and comfort while delivering a non-stop to the worldspace for corporate, VIP and government operators.

The A330 MRTT is the most capable in-flight refuelling platform available.

All A330's combine maturity and reliability with the most up-to-date technology. The fleet consistently achieves an average dispatch reliability of over 99% and annual utilization of up to 6 000 flight hours. At the same time, it is continuously improved by incorporating the latest technologies, to lower operating costs, increase efficiency, improve safety, enhance the passenger product (pioneering the 240-minute ETOPS, introducing RNP to wide-bodies, increasing the MTOW to 242 000 kg (533 519 lb), being the first aircraft to have line-fit connectivity for passengers) and be fully compatible with the Airbus Skywise digital platform.

1-2-1 Glossary

****ON A/C A330-200 A330-200F A330-300 A330-800 A330-900**Glossary

1. List of Abbreviations

A/C	Aircraft
ACN	Aircraft Classification Number
AMM	Aircraft Maintenance Manual
APU	Auxiliary Power Unit
B/C (except A330-200F)	Business Class
C/L	Center Line
CBR	California Bearing Ratio
CC	Cargo Compartment
CG	Center of Gravity
CKPT	Cockpit
E	Young's Modulus
ELEC	Electric, Electrical, Electricity
ESWL	Equivalent Single Wheel Load
F/C (except A330-200F)	First Class
FAA	Federal Aviation Administration
FDL	Fuselage Datum Line
FR	Frame
FSTE	Full Size Trolley Equivalent
FWD	Forward
GPU	Ground Power Unit
GSE	Ground Support Equipment
HYD	Hydraulic
ICAO	International Civil Aviation Organisation
IDG	Integrated Drive Generator
ISA	International Standard Atmosphere
L	Radius of relative stiffness
LCN	Load Classification Number
LD	Load Device
LD	Lower Deck
L/G	Landing Gear
LH	Left Hand
LPS (except A330-200F)	Last Pax Seating
MAC	Mean Aerodynamic Chord

MAX	Maximum
MD	Main Deck
MDCC (A330-200F only)	Main Deck Cargo Compartment
MIN	Minimum
MLG	Main Landing Gear
NLG	Nose Landing Gear
OAT	Outside Air Temperature
PAX (except A330-200F)	Passenger
PB/D (except A330-200F)	Passenger Boarding/Deboarding
PBB	Passenger Boarding Bridge
PCA	Portland Cement Association
PCN	Pavement Classification Number
PRM (except A330-200F)	Passenger with Reduced Mobility
RH	Right Hand
ULD	Unit Load Device
US	United States
WV	Weight Variant
Y/C (except A330-200F)	Economy Class

2. Design Weight Terminology

- Maximum Design Ramp Weight (MRW):
Maximum weight for ground maneuver (including weight of taxi and run-up fuel) as limited by aircraft strength and airworthiness requirements. It is also called Maximum Design Taxi Weight (MTW).
- Maximum Design Landing Weight (MLW):
Maximum weight for landing as limited by aircraft strength and airworthiness requirements.
- Maximum Design Take-Off Weight (MTOW):
Maximum weight for take-off as limited by aircraft strength and airworthiness requirements. (This is the maximum weight at start of the take-off run).
- Maximum Design Zero Fuel Weight (MZFW):
Maximum permissible weight of the aircraft without usable fuel.
- Maximum Seating Capacity:
Maximum number of passengers specifically certified or anticipated for certification.
- Usable Volume:
Usable volume available for cargo, pressurized fuselage, passenger compartment and cockpit.
- Water Volume:
Maximum volume of cargo compartment.
- Usable Fuel:
Fuel available for aircraft propulsion.

AIRCRAFT DESCRIPTION

2-1-1 General Aircraft Characteristics Data

****ON A/C A330-200 A330-300 A330-800 A330-900**

General Aircraft Characteristics Data

****ON A/C A330-300**

1. The following table provides characteristics of A330-300 Models, these data are specific to each Weight Variant:

Aircraft Characteristics				
	WV000	WV001	WV002	WV003
Maximum Taxi Weight (MTW)	212 900 kg	184 900 kg	212 900 kg	215 900 kg
Maximum Ramp Weight (MRW)	(469 364 lb)	(407 635 lb)	(469 364 lb)	(475 978 lb)
Maximum Take-Off Weight (MTOW)	212 000 kg (467 380 lb)	184 000 kg (405 650 lb)	212 000 kg (467 380 lb)	215 000 kg (473 994 lb)
Maximum Landing Weight (MLW)	174 000 kg (383 604 lb)	174 000 kg (383 604 lb)	177 000 kg (390 218 lb)	177 000 kg (390 218 lb)
Maximum Zero Fuel Weight (MZFW)	164 000 kg (361 558 lb)	164 000 kg (361 558 lb)	167 000 kg (368 172 lb)	167 000 kg (368 172 lb)

Aircraft Characteristics				
	WV004 (a)	WV010	WV011	WV012
Maximum Taxi Weight (MTW)	209 900 kg to 215 900 kg	217 900 kg	212 900 kg	218 900 kg
Maximum Ramp Weight (MRW)	(462 750 lb to 475 978 lb)	(480 387 lb)	(469 364 lb)	(482 592 lb)
Maximum Take-Off Weight (MTOW)	209 000 kg to 215 000 kg (460 766 lb to 473 994 lb)	217 000 kg (478 403 lb)	212 000 kg (467 380 lb)	218 000 kg (480 608 lb)
Maximum Landing Weight (MLW)	182 000 kg to 177 000 kg (401 241 lb to 390 218 lb)	179 000 kg (394 627 lb)	177 000 kg (390 218 lb)	182 000 kg (401 241 lb)
Maximum Zero Fuel Weight (MZFW)	172 000 kg to 167 000 kg (379 195 lb to 368 172 lb)	169 000 kg (372 581 lb)	167 000 kg (368 172 lb)	172 000 kg (379 195 lb)

NOTE : (a) Linear MTOW/MZFW trade-off relationship.

Aircraft Characteristics					
	WV013	WV014	WV020	WV022	WV024
Maximum Taxi Weight (MTW)	215 900 kg	205 900 kg	230 900 kg	233 900 kg	205 900 kg
Maximum Ramp Weight (MRW)	(475 978 lb)	(453 932 lb)	(509 047 lb)	(515 661 lb)	(453 932 lb)
Maximum Take-Off Weight (MTOW)	215 000 kg	205 000 kg	230 000 kg	233 000 kg	205 000 kg
	(473 994 lb)	(451 948 lb)	(507 063 lb)	(513 677 lb)	(451 948 lb)
Maximum Landing Weight (MLW)	177 000 kg	182 000 kg	185 000 kg	187 000 kg	185 000 kg
	(390 218 lb)	(401 241 lb)	(407 855 lb)	(412 264 lb)	(407 855 lb)
Maximum Zero Fuel Weight (MZFW)	167 000 kg	172 000 kg	173 000 kg	175 000 kg	173 000 kg
	(368 172 lb)	(379 195 lb)	(381 400 lb)	(385 809 lb)	(381 400 lb)

Aircraft Characteristics					
	WV025	WV026	WV027	WV030	WV031
Maximum Taxi Weight (MTW)	217 900 kg	217 900 kg	198 900 kg	199 900 kg	199 900 kg
Maximum Ramp Weight (MRW)	(480 387 lb)	(480 387 lb)	(438 499 lb)	(440 704 lb)	(440 704 lb)
Maximum Take-Off Weight (MTOW)	217 000 kg	217 000 kg	198 000 kg	199 000 kg	199 000 kg
	(478 403 lb)	(478 403 lb)	(436 515 lb)	(438 720 lb)	(438 720 lb)
Maximum Landing Weight (MLW)	179 000 kg	185 000 kg	185 000 kg	185 000 kg	187 000 kg
	(394 627 lb)	(407 855 lb)	(407 855 lb)	(407 855 lb)	(412 264 lb)
Maximum Zero Fuel Weight (MZFW)	169 000 kg	173 000 kg	173 000 kg	173 000 kg	175 000 kg
	(372 581 lb)	(381 400 lb)	(381 400 lb)	(381 400 lb)	(385 809 lb)

Aircraft Characteristics					
	WV032	WV033	WV034	WV035	WV039
Maximum Taxi Weight (MTW)	190 900 kg	190 900 kg	205 900 kg	205 900 kg	217 900 kg
Maximum Ramp Weight (MRW)	(420 862 lb)	(420 862 lb)	(453 932 lb)	(453 932 lb)	(480 387 lb)
Maximum Take-Off Weight (MTOW)	190 000 kg	190 000 kg	205 000 kg	205 000 kg	217 000 kg
	(418 878 lb)	(418 878 lb)	(451 948 lb)	(451 948 lb)	(478 403 lb)
Maximum Landing Weight (MLW)	185 000 kg	187 000 kg	185 000 kg	187 000 kg	187 000 kg
	(407 855 lb)	(412 264 lb)	(407 855 lb)	(412 264 lb)	(412 264 lb)
Maximum Zero Fuel Weight (MZFW)	173 000 kg	175 000 kg	173 000 kg	175 000 kg	175 000 kg
	(381 400 lb)	(385 809 lb)	(381 400 lb)	(385 809 lb)	(385 809 lb)

Aircraft Characteristics					
	WV050	WV051	WV052	WV053	WV054
Maximum Taxi Weight (MTW)	230 900 kg	212 900 kg	233 900 kg	205 900 kg	235 900 kg
Maximum Ramp Weight (MRW)	(509 047 lb)	(469 364 lb)	(515 661 lb)	(453 932 lb)	(520 070 lb)

Aircraft Characteristics					
	WV050	WV051	WV052	WV053	WV054
Maximum Take-Off Weight (MTOW)	230 000 kg (507 063 lb)	212 000 kg (467 380 lb)	233 000 kg (513 677 lb)	205 000 kg (451 948 lb)	235 000 kg (518 086 lb)
Maximum Landing Weight (MLW)	185 000 kg (407 855 lb)	187 000 kg (412 264 lb)	187 000 kg (412 264 lb)	185 000 kg (407 855 lb)	187 000 kg (412 264 lb)
Maximum Zero Fuel Weight (MZFW)	173 000 kg (381 400 lb)	175 000 kg (385 809 lb)	175 000 kg (385 809 lb)	173 000 kg (381 400 lb)	173 000 kg (381 400 lb)

Aircraft Characteristics				
	WV055 (b)	WV056	WV057	WV058
Maximum Taxi Weight (MTW) Maximum Ramp Weight (MRW)	235 900 kg (520 070 lb)	205 900 kg (453 932 lb)	184 900 kg (407 635 lb)	215 900 kg (475 978 lb)
Maximum Take-Off Weight (MTOW)	235 000 kg (518 086 lb)	205 000 kg (451 948 lb)	184 000 kg (405 650 lb)	215 000 kg (473 994 lb)
Maximum Landing Weight (MLW)	187 000 kg (412 264 lb)	187 000 kg (412 264 lb)	174 000 kg (383 604 lb)	187 000 kg (412 264 lb)
Maximum Zero Fuel Weight (MZFW)	173 000 kg to 175 000 kg (381 400 lb to 385 809 lb)	175 000 kg (385 809 lb)	164 000 kg (361 558 lb)	173 000 kg (381 400 lb)

NOTE : (b) Dynamic Payload between WV052 and WV054.

Aircraft Characteristics				
	WV059	WV060	WV080	WV081
Maximum Taxi Weight (MTW) Maximum Ramp Weight (MRW)	217 900 kg (480 387 lb)	198 900 kg (438 499 lb)	238 900 kg (526 684 lb)	242 900 kg (535 503 lb)
Maximum Take-Off Weight (MTOW)	217 000 kg (478 403 lb)	198 000 kg (436 515 lb)	238 000 kg (524 700 lb)	242 000 kg (533 519 lb)
Maximum Landing Weight (MLW)	185 000 kg (407 855 lb)	185 000 kg (407 855 lb)	187 000 kg (412 264 lb)	187 000 kg (412 264 lb)
Maximum Zero Fuel Weight (MZFW)	173 000 kg (381 400 lb)	173 000 kg (381 400 lb)	175 000 kg (385 809 lb)	171 000 kg (376 990 lb)

Aircraft Characteristics		
	WV082 (c)	WV083
Maximum Taxi Weight (MTW)	242 900 kg	240 900 kg
Maximum Ramp Weight (MRW)	(535 503 lb)	(531 093 lb)
Maximum Take-Off Weight (MTOW)	242 000 kg (533 519 lb)	240 000 kg (529 109 lb)
Maximum Landing Weight (MLW)	187 000 kg (412 264 lb)	187 000 kg (412 264 lb)
Maximum Zero Fuel Weight (MZFW)	171 000 kg to 175 000 kg (376 990 lb to 385 809 lb)	173 000 kg (381 400 lb)

NOTE : (c) Dynamic Payload between WV080 and WV081.

****ON A/C A330-900**

2. The following table provides characteristics of A330-900 Models, these data are specific to each Weight Variant:

Aircraft Characteristics			
	WV900 (d)	WV901	WV902
Maximum Taxi Weight (MTW)	242 900 kg	242 900 kg	238 900 kg
Maximum Ramp Weight (MRW)	(535 503 lb)	(535 503 lb)	(526 684 lb)
Maximum Take-Off Weight (MTOW)	242 000 kg (533 519 lb)	242 000 kg (533 519 lb)	238 000 kg (524 700 lb)
Maximum Landing Weight (MLW)	191 000 kg (421 083 lb)	191 000 kg (421 083 lb)	191 000 kg (421 083 lb)
Maximum Zero Fuel Weight (MZFW)	177 000 kg to 181 000 kg (390 218 lb to 399 037 lb)	177 000 kg (390 218 lb)	181 000 kg (399 037 lb)

NOTE : (d) Dynamic Payload between WV901 and WV902.

Aircraft Characteristics			
	WV903	WV904	WV905
Maximum Taxi Weight (MTW)	234 900 kg	230 900 kg	220 900 kg
Maximum Ramp Weight (MRW)	(517 866 lb)	(509 047 lb)	(487 001 lb)
Maximum Take-Off Weight (MTOW)	234 000 kg (515 882 lb)	230 000 kg (507 063 lb)	220 000 kg (485 017 lb)

Aircraft Characteristics			
	WV903	WV904	WV905
Maximum Landing Weight (MLW)	191 000 kg (421 083 lb)	191 000 kg (421 083 lb)	191 000 kg (421 083 lb)
Maximum Zero Fuel Weight (MZFW)	181 000 kg (399 037 lb)	181 000 kg (399 037 lb)	181 000 kg (399 037 lb)

Aircraft Characteristics			
	WV906	WV907	WV908
Maximum Taxi Weight (MTW)	215 900 kg (475 978 lb)	210 900 kg (464 955 lb)	205 900 kg (453 932 lb)
Maximum Ramp Weight (MRW)	215 000 kg (473 994 lb)	210 000 kg (462 971 lb)	205 000 kg (451 948 lb)
Maximum Take-Off Weight (MTOW)	191 000 kg (421 083 lb)	191 000 kg (421 083 lb)	191 000 kg (421 083 lb)
Maximum Landing Weight (MLW)	181 000 kg (399 037 lb)	181 000 kg (399 037 lb)	181 000 kg (399 037 lb)

Aircraft Characteristics			
	WV920 (e)	WV921	WV922
Maximum Taxi Weight (MTW)	251 900 kg (555 344 lb)	251 900 kg (555 344 lb)	247 900 kg (546 526 lb)
Maximum Ramp Weight (MRW)	251 000 kg (553 360 lb)	251 000 kg (553 360 lb)	247 000 kg (544 542 lb)
Maximum Take-Off Weight (MTOW)	191 000 kg (421 083 lb)	191 000 kg (421 083 lb)	191 000 kg (421 083 lb)
Maximum Landing Weight (MLW)	177 000 kg to 181 000 kg (390 218 lb) to (399 037 lb)	177 000 kg (390 218 lb)	181 000 kg (399 037 lb)

NOTE : (e) Dynamic Payload between WV921 and WV922.

****ON A/C A330-300 A330-900**

3. The following table provides characteristics of A330-300 and A330-900 Models, these data are common to each Weight Variant:

Aircraft Characteristics		
Standard Seating Capacity (in a two class layout)	A330-300 : 300	
	A330-900 : 310	
Usable Fuel Capacity (density = 0.785 kg/l)	97 530 l (25 765 US gal)	139 090 l * (36 744 US gal) *
	76 561 kg (168 787 lb)	109 185 kg * (240 711 lb) *
Pressurized Fuselage Volume (A/C non equipped)	1 056 m ³ (37 292 ft ³)	
Passenger Compartment Volume	372 m ³ (13 137 ft ³)	
Cockpit Volume	12 m ³ (424 ft ³)	
Usable Volume, FWD CC (Based on LD3)	78 m ³ (2 754 ft ³)	
Usable Volume, AFT CC (Based on LD3)	60.7 m ³ (2 142 ft ³)	
Usable Volume, Bulk CC	19.7 m ³ (695 ft ³)	
Water Volume, FWD CC	107 m ³ (3 789 ft ³)	
Water Volume, AFT CC	85.7 m ³ (3 026 ft ³)	
Water Volume, Bulk CC	22.7 m ³ (802 ft ³)	

NOTE : * OPTION: WV08X and A330-900 (all WV).

****ON A/C A330-200**

4. The following table provides characteristics of A330-200 Models, these data are specific to each Weight Variant:

Aircraft Characteristics					
	WV020	WV021	WV022	WV023	WV024
Maximum Taxi Weight (MTW) Maximum Ramp Weight (MRW)	230 900 kg (509 047 lb)	230 900 kg (509 047 lb)	233 900 kg (515 661 lb)	233 900 kg (515 661 lb)	202 900 kg (447 318 lb)
Maximum Take-Off Weight (MTOW)	230 000 kg (507 063 lb)	230 000 kg (507 063 lb)	233 000 kg (513 677 lb)	233 000 kg (513 677 lb)	202 000 kg (445 334 lb)
Maximum Landing Weight (MLW)	180 000 kg (396 832 lb)	182 000 kg (401 241 lb)	182 000 kg (401 241 lb)	180 000 kg (396 832 lb)	180 000 kg (396 832 lb)
Maximum Zero Fuel Weight (MZFW)	168 000 kg (370 376 lb)	170 000 kg (374 786 lb)	170 000 kg (374 786 lb)	168 000 kg (370 376 lb)	168 000 kg (370 376 lb)

Aircraft Characteristics					
	WV025	WV026	WV027	WV050	WV051
Maximum Taxi Weight (MTW) Maximum Ramp Weight (MRW)	220 900 kg (487 001 lb)	192 900 kg (425 272 lb)	220 900 kg (487 001 lb)	230 900 kg (509 047 lb)	192 900 kg (425 272 lb)
Maximum Take-Off Weight (MTOW)	220 000 kg (485 017 lb)	192 000 kg (423 287 lb)	220 000 kg (485 017 lb)	230 000 kg (507 063 lb)	192 000 kg (423 287 lb)
Maximum Landing Weight (MLW)	182 000 kg (401 241 lb)	180 000 kg (396 832 lb)	180 000 kg (396 832 lb)	180 000 kg (396 832 lb)	180 000 kg (396 832 lb)
Maximum Zero Fuel Weight (MZFW)	170 000 kg (374 786 lb)	168 000 kg (370 376 lb)	168 000 kg (370 376 lb)	168 000 kg (370 376 lb)	168 000 kg (370 376 lb)

Aircraft Characteristics					
	WV052	WV053	WV054	WV055	WV056
Maximum Taxi Weight (MTW) Maximum Ramp Weight (MRW)	233 900 kg (515 661 lb)	210 900 kg (464 955 lb)	230 900 kg (509 047 lb)	192 900 kg (425 272 lb)	233 900 kg (515 661 lb)

Aircraft Characteristics					
	WV052	WV053	WV054	WV055	WV056
Maximum Take-Off Weight (MTOW)	233 000 kg (513 677 lb)	210 000 kg (462 971 lb)	230 000 kg (507 063 lb)	192 000 kg (423 287 lb)	233 000 kg (513 677 lb)
Maximum Landing Weight (MLW)	182 000 kg (401 241 lb)	180 000 kg (396 832 lb)	182 000 kg (401 241 lb)	182 000 kg (401 241 lb)	180 000 kg (396 832 lb)
Maximum Zero Fuel Weight (MZFW)	170 000 kg (374 786 lb)	168 000 kg (370 376 lb)	170 000 kg (374 786 lb)	170 000 kg (374 786 lb)	168 000 kg (370 376 lb)

Aircraft Characteristics					
	WV057	WV058	WV059	WV060	WV061
Maximum Taxi Weight (MTW) Maximum Ramp Weight (MRW)	236 900 kg (522 275 lb)	238 900 kg (526 684 lb)	202 900 kg (447 318 lb)	220 900 kg (487 001 lb)	230 900 kg (509 047 lb)
Maximum Take-Off Weight (MTOW)	236 000 kg (520 291 lb)	238 000 kg (524 700 lb)	202 000 kg (445 334 lb)	220 000 kg (485 017 lb)	230 000 kg (507 063 lb)
Maximum Landing Weight (MLW)	182 000 kg (401 241 lb)	182 000 kg (401 241 lb)	182 000 kg (401 241 lb)	182 000 kg (401 240 lb)	182 000 kg (401 240 lb)
Maximum Zero Fuel Weight (MZFW)	170 000 kg (374 786 lb)	168 000 kg (370 376 lb)	170 000 kg (374 786 lb)	170 000 kg (374 786 lb)	168 000 kg (370 376 lb)

Aircraft Characteristics				
	WV062 (f)	WV063	WV064	WV080
Maximum Taxi Weight (MTW) Maximum Ramp Weight (MRW)	238 900 kg (526 684 lb)	192 900 kg (425 272 lb)	217 900 kg (480 387 lb)	238 900 kg (526 684 lb)
Maximum Take-Off Weight (MTOW)	238 000 kg (524 700 lb)	192 000 kg (423 287 lb)	217 000 kg (478 403 lb)	238 000 kg (524 700 lb)
Maximum Landing Weight (MLW)	182 000 kg (401 241 lb)	182 000 kg (401 241 lb)	182 000 kg (401 241 lb)	182 000 kg (401 241 lb)

Aircraft Characteristics				
	WV062 (f)	WV063	WV064	WV080
Maximum Zero Fuel Weight (MZFW)	168 000 kg to 170 000 kg (370 376 lb to 374 786 lb)	168 000 kg (370 376 lb)	168 000 kg (370 376 lb)	170 000 kg (374 786 lb)

NOTE : (f) Dynamic Payload between WV057 and WV058.

Aircraft Characteristics			
	WV081	WV082 (g)	WV083
Maximum Taxi Weight (MTW) Maximum Ramp Weight (MRW)	242 900 kg (535 503 lb)	242 900 kg (535 503 lb)	240 900 kg (531 093 lb)
Maximum Take-Off Weight (MTOW)	242 000 kg (533 519 lb)	242 000 kg (533 519 lb)	240 000 kg (529 109 lb)
Maximum Landing Weight (MLW)	182 000 kg (401 241 lb)	182 000 kg (401 241 lb)	182 000 kg (401 241 lb)
Maximum Zero Fuel Weight (MZFW)	166 000 kg (365 967 lb)	166 000 kg to 170 000 kg (365 967 lb to 374 786 lb)	168 000 kg (370 376 lb)

NOTE : (g) Dynamic Payload between WV080 and WV081.

****ON A/C A330-800**

5. The following table provides characteristics of A330-800 Models, these data are specific to each Weight Variant:

Aircraft Characteristics			
	WV800 (h)	WV801	WV802
Maximum Taxi Weight (MTW) Maximum Ramp Weight (MRW)	242 900 kg (535 503 lb)	242 900 kg (535 503 lb)	238 900 kg (526 684 lb)
Maximum Take-Off Weight (MTOW)	242 000 kg (533 519 lb)	242 000 kg (533 519 lb)	230 000 kg (507 063 lb)
Maximum Landing Weight (MLW)	186 000 kg (410 060 lb)	186 000 kg (410 060 lb)	186 000 kg (410 060 lb)

Aircraft Characteristics			
	WV800 (h)	WV801	WV802
Maximum Zero Fuel Weight (MZFW)	172 000 kg to 176 000 kg (379 195 lb to 388 013 lb)	172 000 kg (379 195 lb)	176 000 kg (388 013 lb)

NOTE : (h) Dynamic Payload between WV801 and WV802.

Aircraft Characteristics			
	WV803	WV804	WV805
Maximum Taxi Weight (MTW)	234 900 kg	230 900 kg	220 900 kg
Maximum Ramp Weight (MRW)	(517 866 lb)	(509 047 lb)	(487 001 lb)
Maximum Take-Off Weight (MTOW)	234 000 kg (515 882 lb)	230 000 kg (507 063 lb)	220 000 kg (485 017 lb)
Maximum Landing Weight (MLW)	186 000 kg (410 060 lb)	186 000 kg (410 060 lb)	186 000 kg (410 060 lb)
Maximum Zero Fuel Weight (MZFW)	176 000 kg (388 013 lb)	176 000 kg (388 013 lb)	176 000 kg (388 013 lb)

Aircraft Characteristics				
	WV806	WV807	WV808	WV809
Maximum Taxi Weight (MTW)	215 900 kg	210 900 kg	205 900 kg	200 900 kg
Maximum Ramp Weight (MRW)	(475 978 lb)	(464 955 lb)	(453 932 lb)	(442 909 lb)
Maximum Take-Off Weight (MTOW)	215 000 kg (473 994 lb)	210 000 kg (462 971 lb)	205 000 kg (451 948 lb)	200 000 kg (440 924 lb)
Maximum Landing Weight (MLW)	186 000 kg (410 060 lb)	186 000 kg (410 060 lb)	186 000 kg (410 060 lb)	186 000 kg (410 060 lb)
Maximum Zero Fuel Weight (MZFW)	176 000 kg (388 013 lb)	176 000 kg (388 013 lb)	176 000 kg (388 013 lb)	176 000 kg (388 013 lb)

Aircraft Characteristics			
	WV820 (j)	WV821	WV822
Maximum Taxi Weight (MTW)	251 900 kg	251 900 kg	247 900 kg
Maximum Ramp Weight (MRW)	(555 344 lb)	(555 344 lb)	(546 526 lb)
Maximum Take-Off Weight (MTOW)	251 000 kg (553 360 lb)	251 000 kg (553 360 lb)	247 000 kg (544 542 lb)
Maximum Landing Weight (MLW)	186 000 kg (410 060 lb)	186 000 kg (410 060 lb)	186 000 kg (410 060 lb)

Aircraft Characteristics			
	WV820 (j)	WV821	WV822
Maximum Zero Fuel Weight (MZFW)	172 000 kg to 176 000 kg (379 195 lb) to (388 013 lb)	172 000 kg (379 195 lb)	176 000 kg (388 013 lb)

NOTE : (j) Dynamic Payload between WV821 and WV822.

****ON A/C A330-200 A330-800**

6. The following table provides characteristics of A330-200 and A330-800 Models, these data are common to each Weight Variant:

Aircraft Characteristics	
Standard Seating Capacity (in a two class layout)	A330-200 : 247
	A330-800 : 257
Usable Fuel Capacity (density = 0.785 kg/l)	139 090 l (36 744 US gal)
	109 185 kg (240 711 lb)
Pressurized Fuselage Volume (A/C non equipped)	950 m ³ (33 548 ft ³)
Passenger Compartment Volume	335 m ³ (11 830 ft ³)
Cockpit Volume	12 m ³ (424 ft ³)
Usable Volume, FWD CC (Based on LD3)	60.7 m ³ (2 142 ft ³)
Usable Volume, AFT CC (Based on LD3)	52 m ³ (1 836 ft ³)
Usable Volume, Bulk CC	19.7 m ³ (695 ft ³)
Water Volume, FWD CC	84.6 m ³ (2 988 ft ³)
Water Volume, AFT CC	71.1 m ³ (2 511 ft ³)
Water Volume, Bulk CC	22.7 m ³ (802 ft ³)

****ON A/C A330-200F**

General Aircraft Characteristics Data

1. The following table provides characteristics of A330-200F Models, these data are specific to each Weight Variant:

Aircraft Characteristics			
	WV000	WV001	WV002*
Maximum Taxi Weight (MTW) Maximum Ramp Weight (MRW)	233 900 kg (515 661 lb)	227 900 kg (502 433 lb)	233 900 kg (515 661 lb)
Maximum Take-Off Weight (MTOW)	233 000 kg (513 677 lb)	227 000 kg (500 449 lb)	233 000 kg (513 677 lb)
Maximum Landing Weight (MLW)	182 000 kg (401 241 lb)	187 000 kg (412 264 lb)	187 000 kg (412 264 lb)
Maximum Zero Fuel Weight (MZFW)	173 000 kg (381 400 lb)	178 000 kg (392 423 lb)	173 000 kg to 178 000 kg (381 399 lb to 392 422 lb)
Estimated Maximum Payload PW 4000	64 742 kg (142 732 lb)	69 742 kg (153 755 lb)	64 742 kg to 69 742 kg (142 732 lb to 153 755 lb)
Estimated Maximum Payload TRENT 700	65 000 kg (143 300 lb)	70 000 kg (154 324 lb)	65 000 kg to 70 000 kg (143 300 lb to 154 324 lb)

NOTE : * Dynamic Payload between WV000 and WV001

2. The following table provides characteristics of A330-200F Models, these data are common to each Weight Variant:

Aircraft Characteristics	
Supernumerary area	6
Usable Fuel Capacity (density = 0.785 kg/l)	97 530 l (25 765 US gal)
Pressurized Fuselage Volume (A/C non equipped)	900 m ³ (31 783 ft ³)
Cockpit Volume	12 m ³ (424 ft ³)

Aircraft Characteristics	
Main Deck Cargo Compartment Usable Volume (Based on 96" x 125" pallet)	336.8 m ³ (11 894 ft ³)
Main Deck Cargo Compartment Water Volume	466.5 m ³ (16 474 ft ³)
Usable Volume, FWD CC (Based on LD3)	60.7 m ³ (2 142 ft ³)
Usable Volume, AFT CC (Based on LD3)	52 m ³ (1 836 ft ³)
Usable Volume, Bulk CC	19.7 m ³ (695 ft ³)
Water Volume, FWD CC	84.6 m ³ (2 988 ft ³)
Water Volume, AFT CC	71.1 m ³ (2 511 ft ³)
Water Volume, Bulk CC	22.7 m ³ (802 ft ³)



2-2-0 General Aircraft Dimensions

**ON A/C A330-200 A330-300 A330-800 A330-900

General Aircraft Dimensions

1. This section provides general aircraft dimensions for pax version.

****ON A/C A330-300**

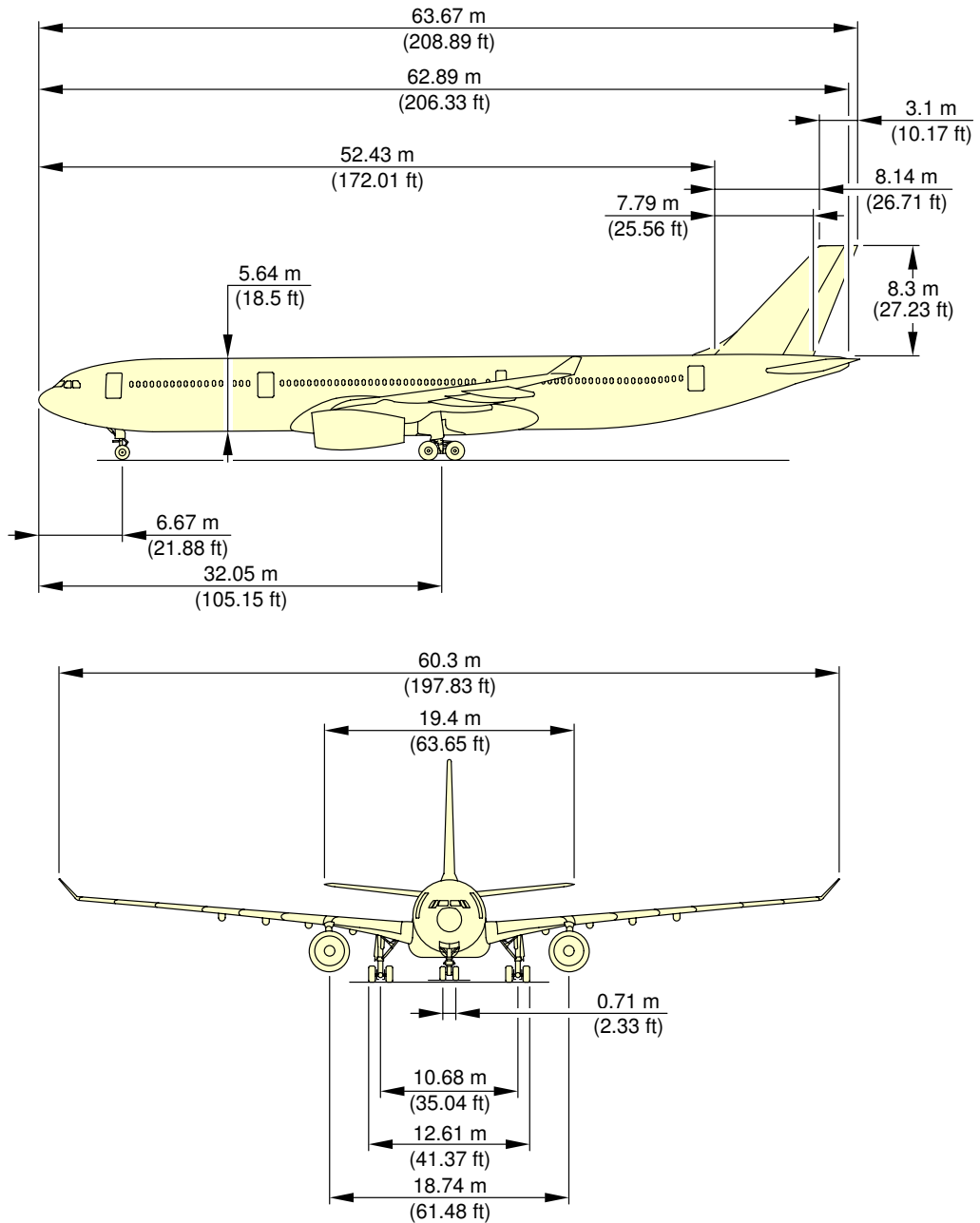

NOTE:
RELATED TO AIRCRAFT ATTITUDE AND WEIGHT.

F_AC_020200_1_0010101_01_02

General Aircraft Dimensions
(Sheet 1 of 2)
FIGURE-2-2-0-991-001-A01

****ON A/C A330-300**

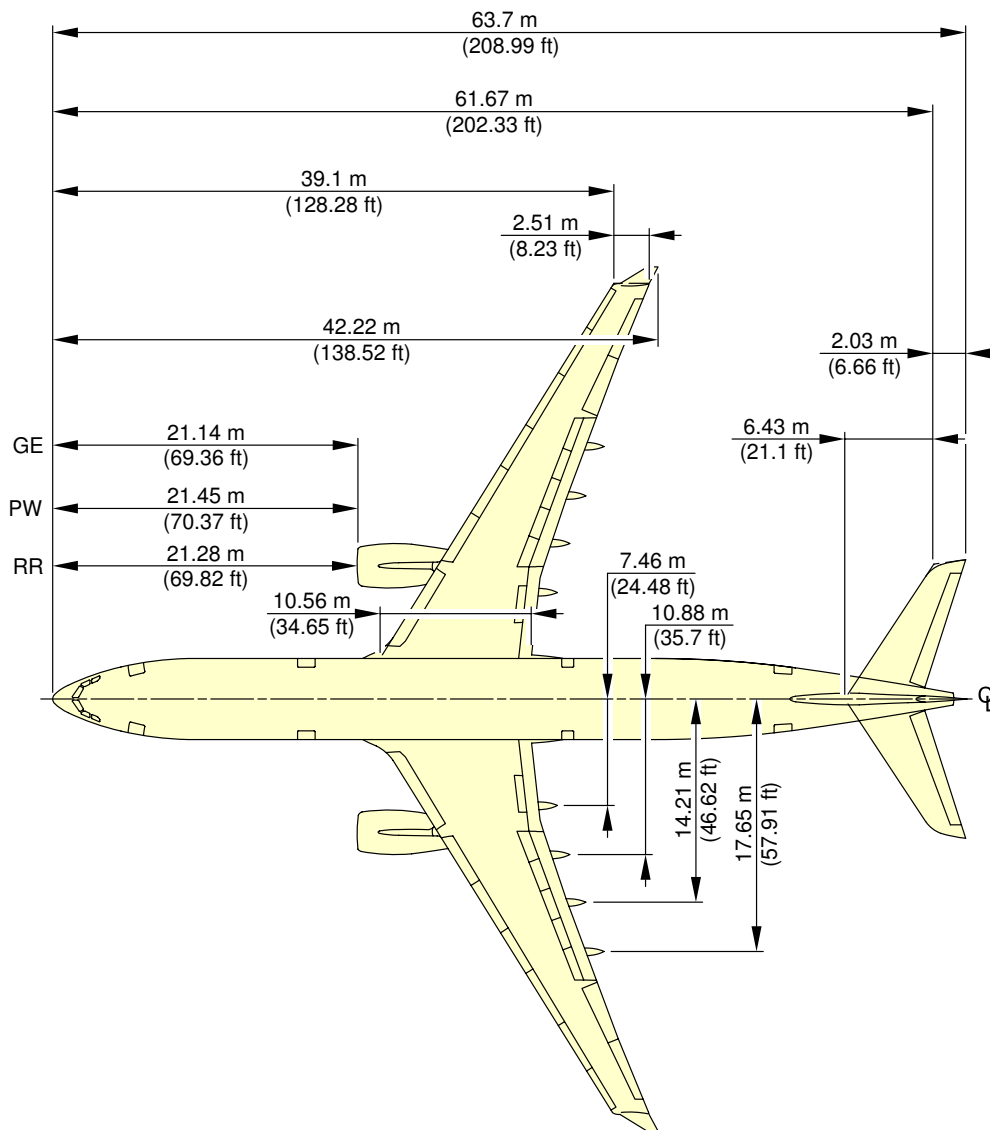

NOTE:
RELATED TO AIRCRAFT ATTITUDE AND WEIGHT.

F_AC_020200_1_0010104_01_00

General Aircraft Dimensions
(Sheet 2 of 2)
FIGURE-2-2-0-991-001-A01

****ON A/C A330-200**

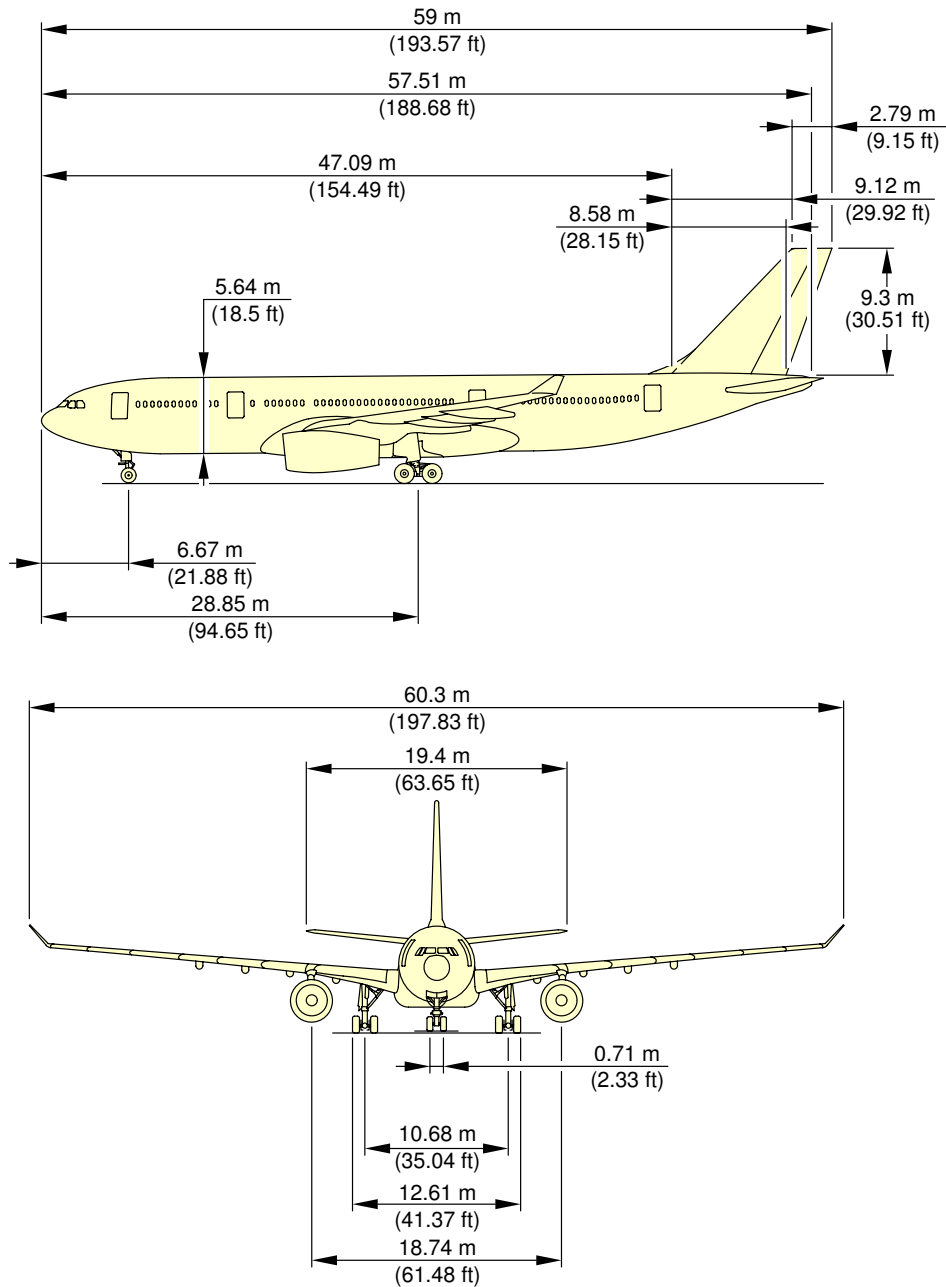

NOTE:
RELATED TO AIRCRAFT ATTITUDE AND WEIGHT.

F_AC_020200_1_0020101_01_02

General Aircraft Dimensions
(Pre Mod 48979) (Sheet 1 of 3)
FIGURE-2-2-0-991-002-A01

****ON A/C A330-200**

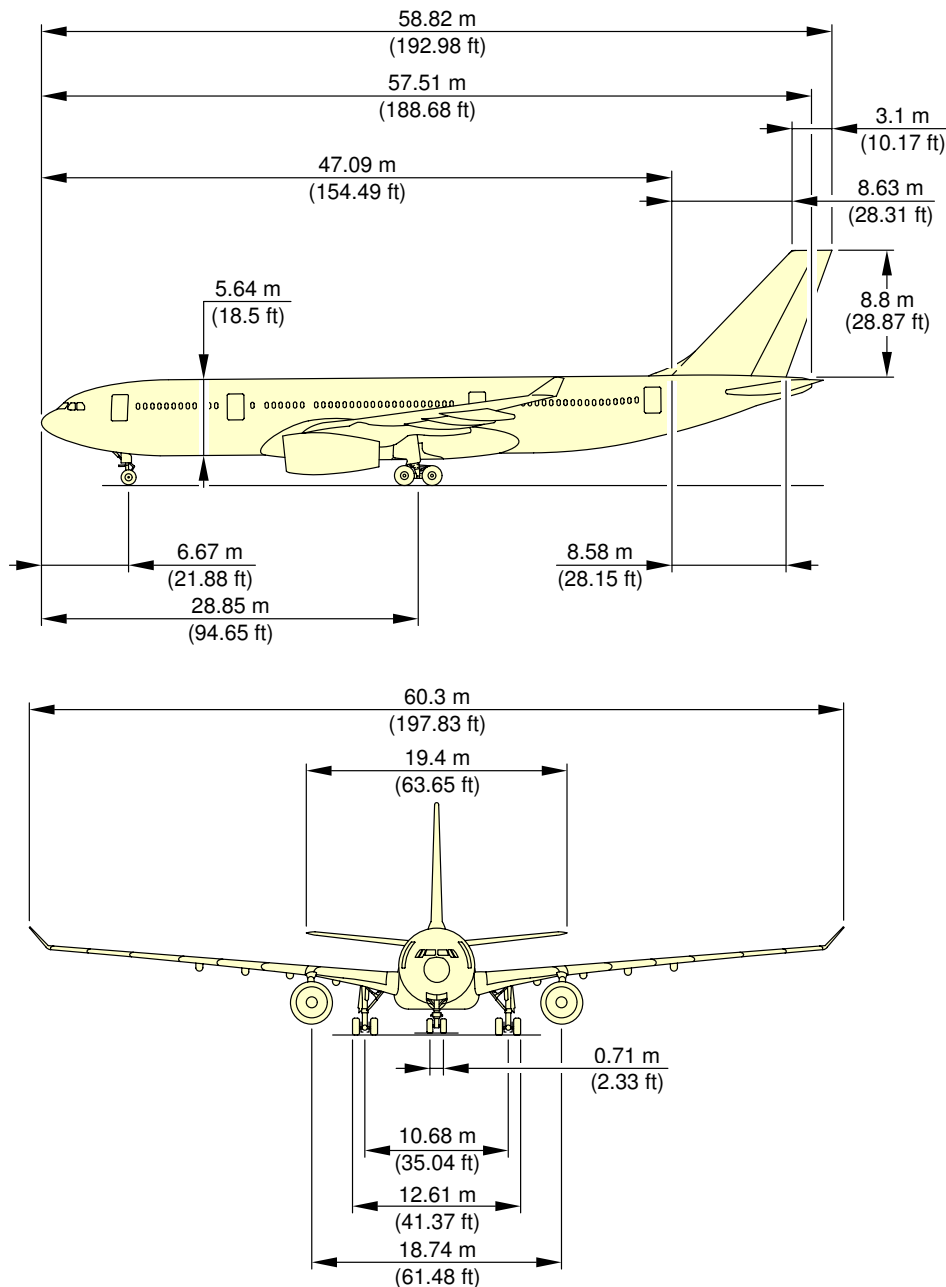

NOTE:
RELATED TO AIRCRAFT ATTITUDE AND WEIGHT.

F_AC_020200_1_0020103_01_00

General Aircraft Dimensions
(Post Mod 48979) (Sheet 2 of 3)
FIGURE-2-2-0-991-002-A01

****ON A/C A330-200**

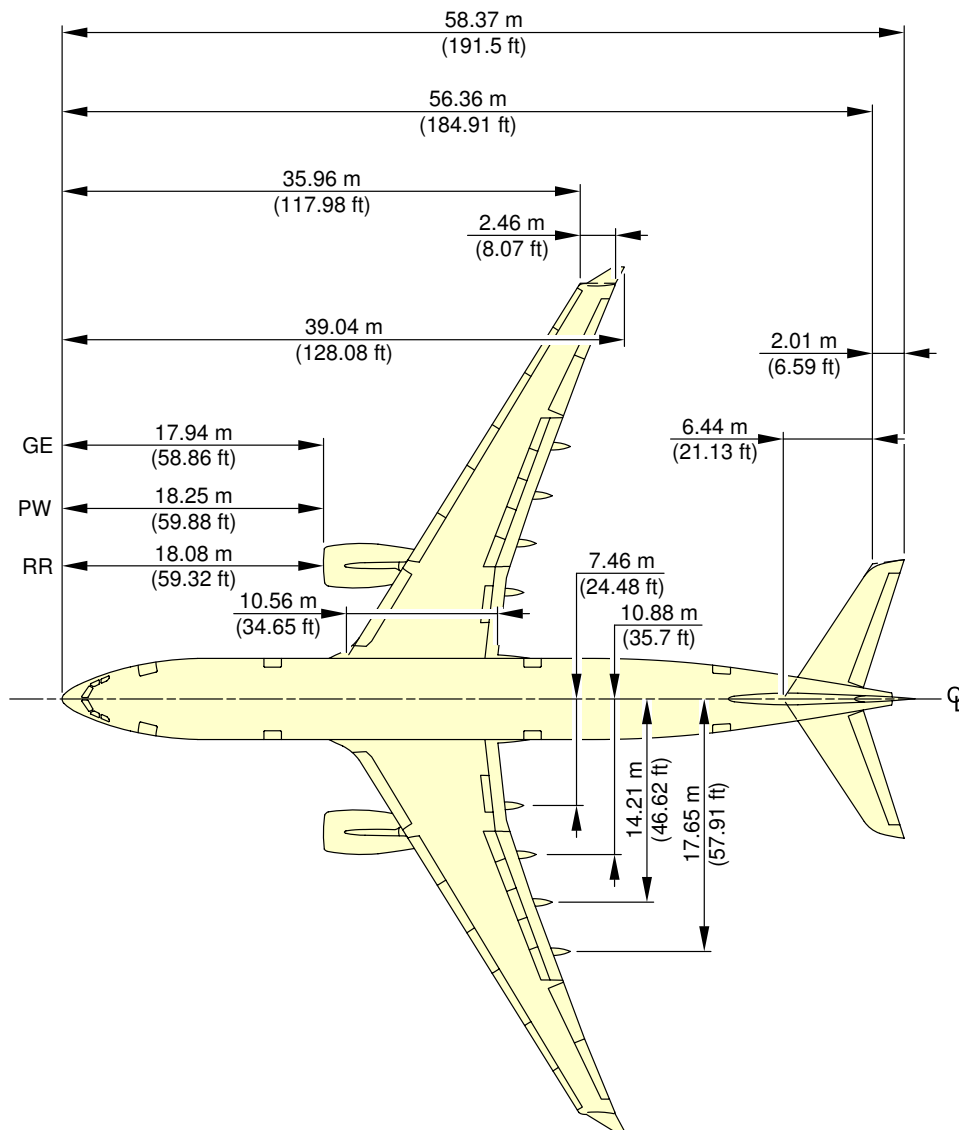

NOTE:
RELATED TO AIRCRAFT ATTITUDE AND WEIGHT.

F_AC_020200_1_0020102_01_00

General Aircraft Dimensions
(Sheet 3 of 3)
FIGURE-2-2-0-991-002-A01

****ON A/C A330-900**

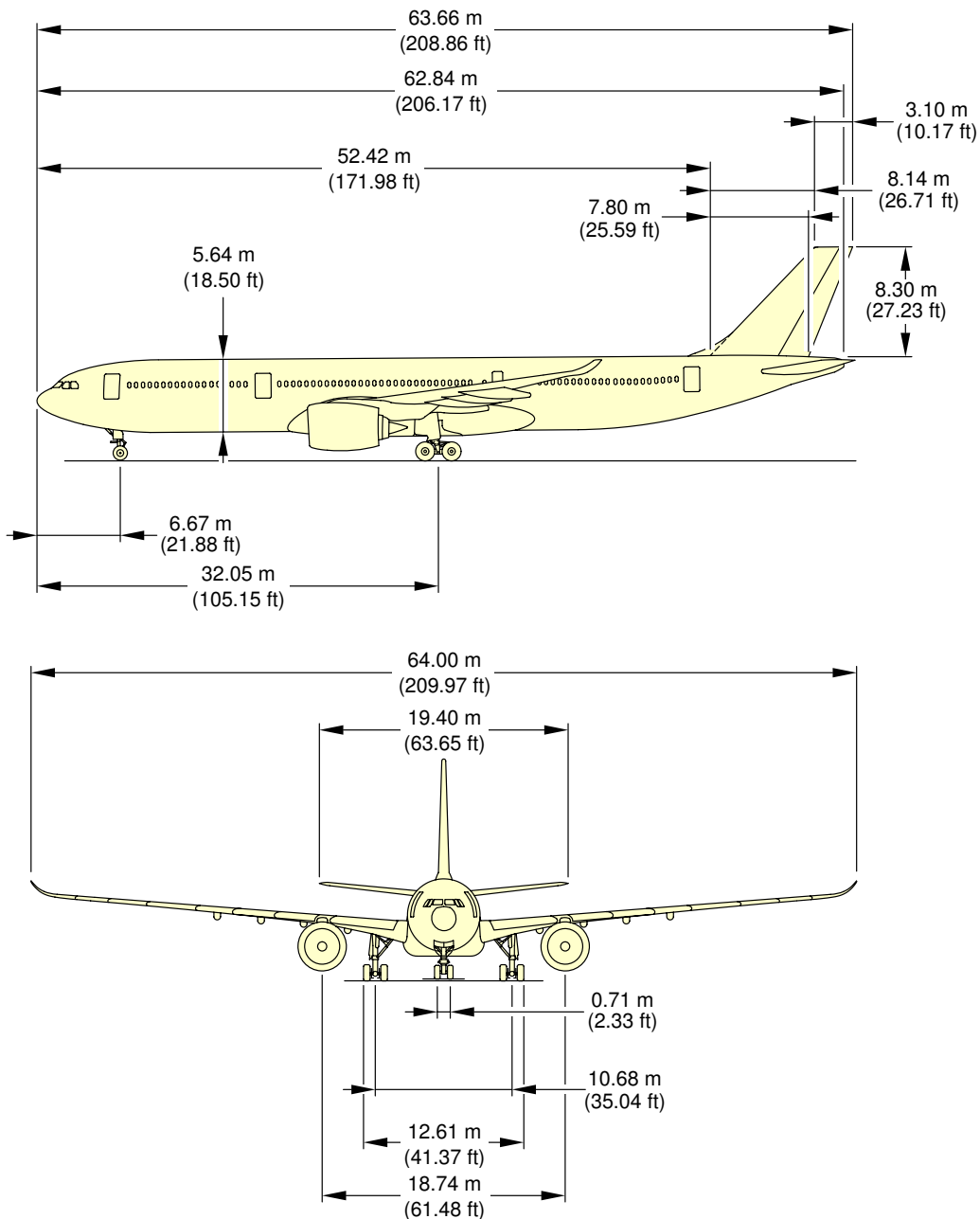

NOTE:
RELATED TO AIRCRAFT ATTITUDE AND WEIGHT.

F_AC_020200_1_0110101_01_00

General Aircraft Dimensions
(Sheet 1 of 2)
FIGURE-2-2-0-991-011-A01

**ON A/C A330-900

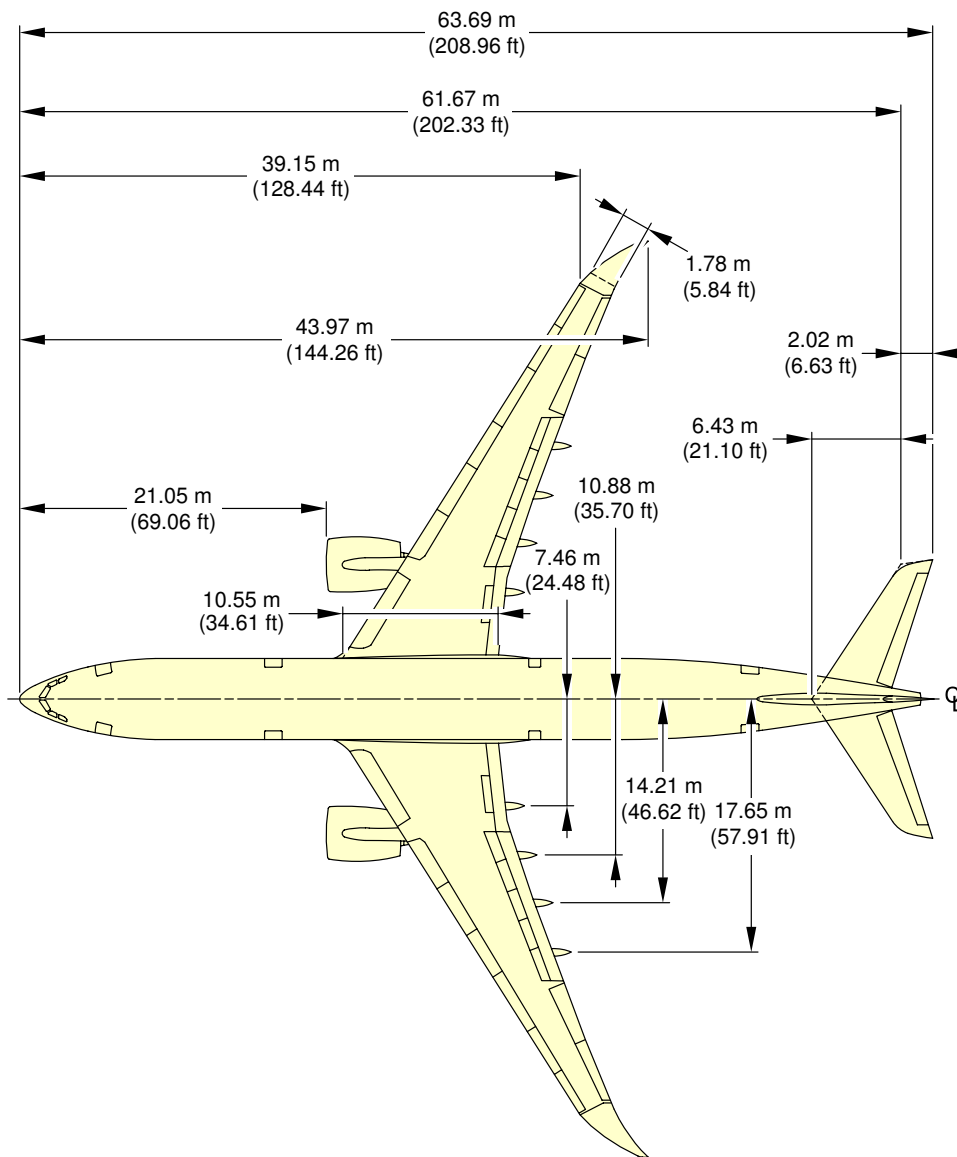

NOTE:
RELATED TO AIRCRAFT ATTITUDE AND WEIGHT.

F_AC_020200_1_0110102_01_00

General Aircraft Dimensions
(Sheet 2 of 2)
FIGURE-2-2-0-991-011-A01

****ON A/C A330-800**

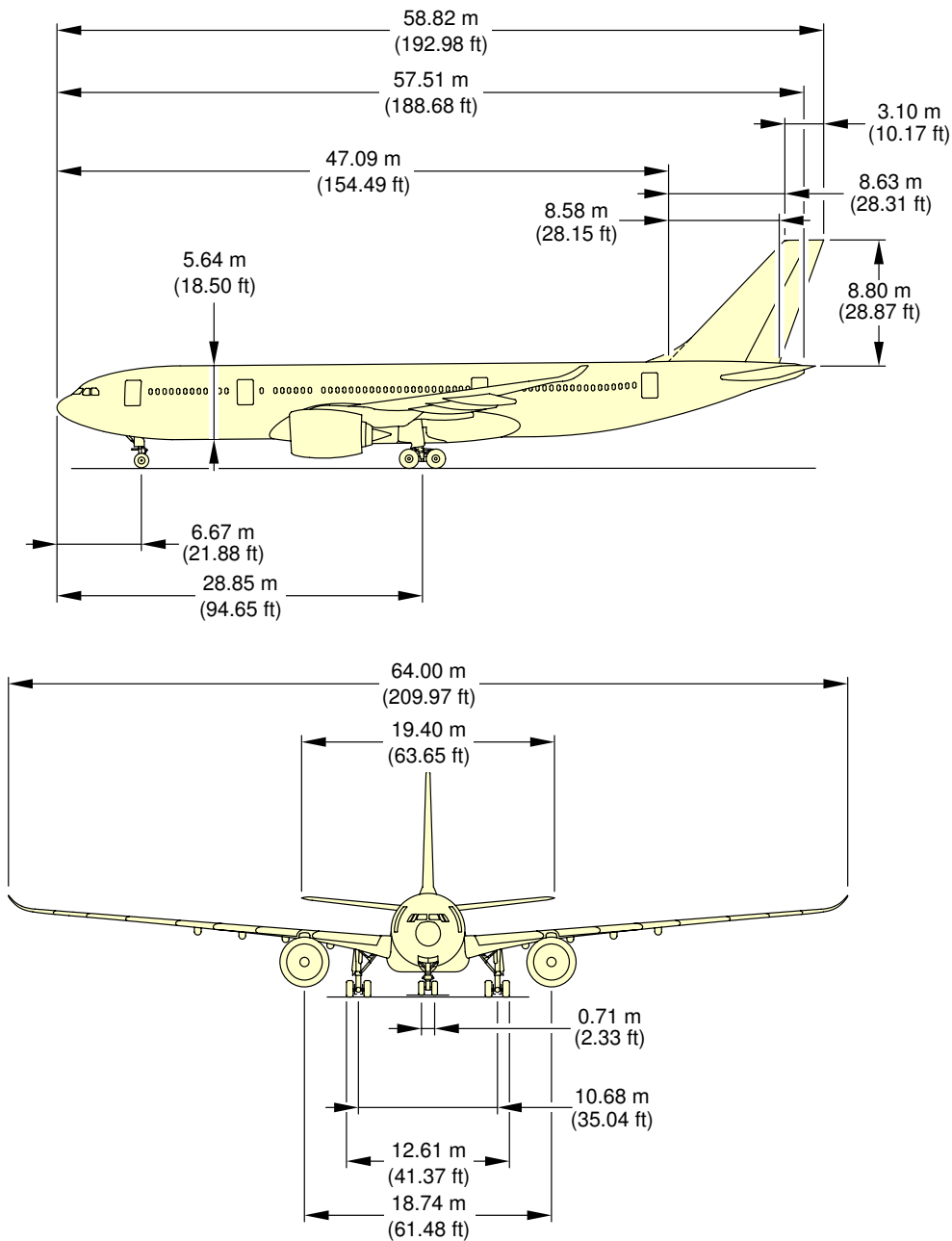

NOTE:
RELATED TO AIRCRAFT ATTITUDE AND WEIGHT.

F_AC_020200_1_0120101_01_00

General Aircraft Dimensions
(Sheet 1 of 2)
FIGURE-2-2-0-991-012-A01

****ON A/C A330-800**

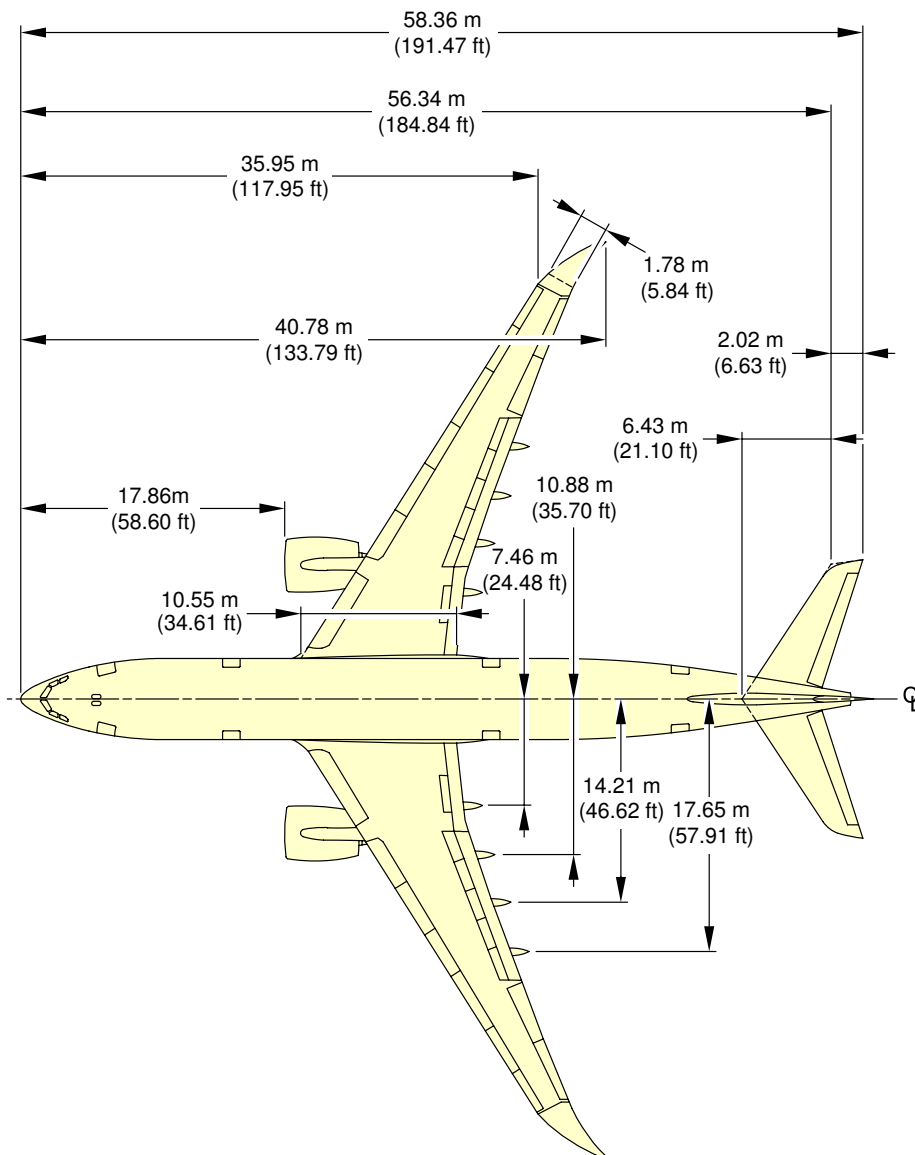

NOTE:
RELATED TO AIRCRAFT ATTITUDE AND WEIGHT.

F_AC_020200_1_0120102_01_00

General Aircraft Dimensions
(Sheet 2 of 2)
FIGURE-2-2-0-991-012-A01



****ON A/C A330-200F**

General Aircraft Dimensions

1. This section provides general aircraft dimensions for cargo version.

****ON A/C A330-200F**

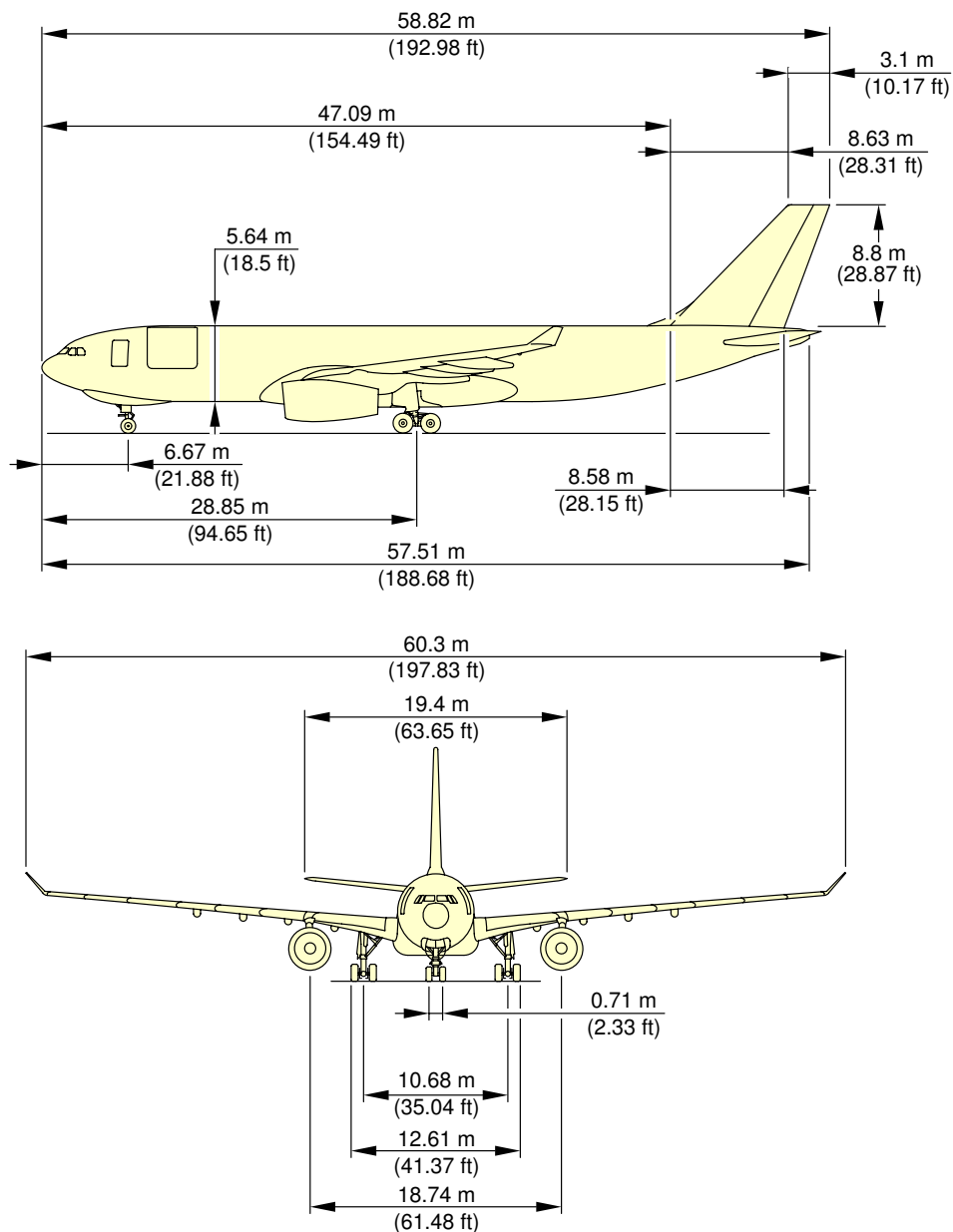

NOTE:
RELATED TO AIRCRAFT ATTITUDE AND WEIGHT.

F_AC_020200_1_0030101_01_02

General Aircraft Dimensions
(Sheet 1 of 2)
FIGURE-2-2-0-991-003-A01

****ON A/C A330-200F**

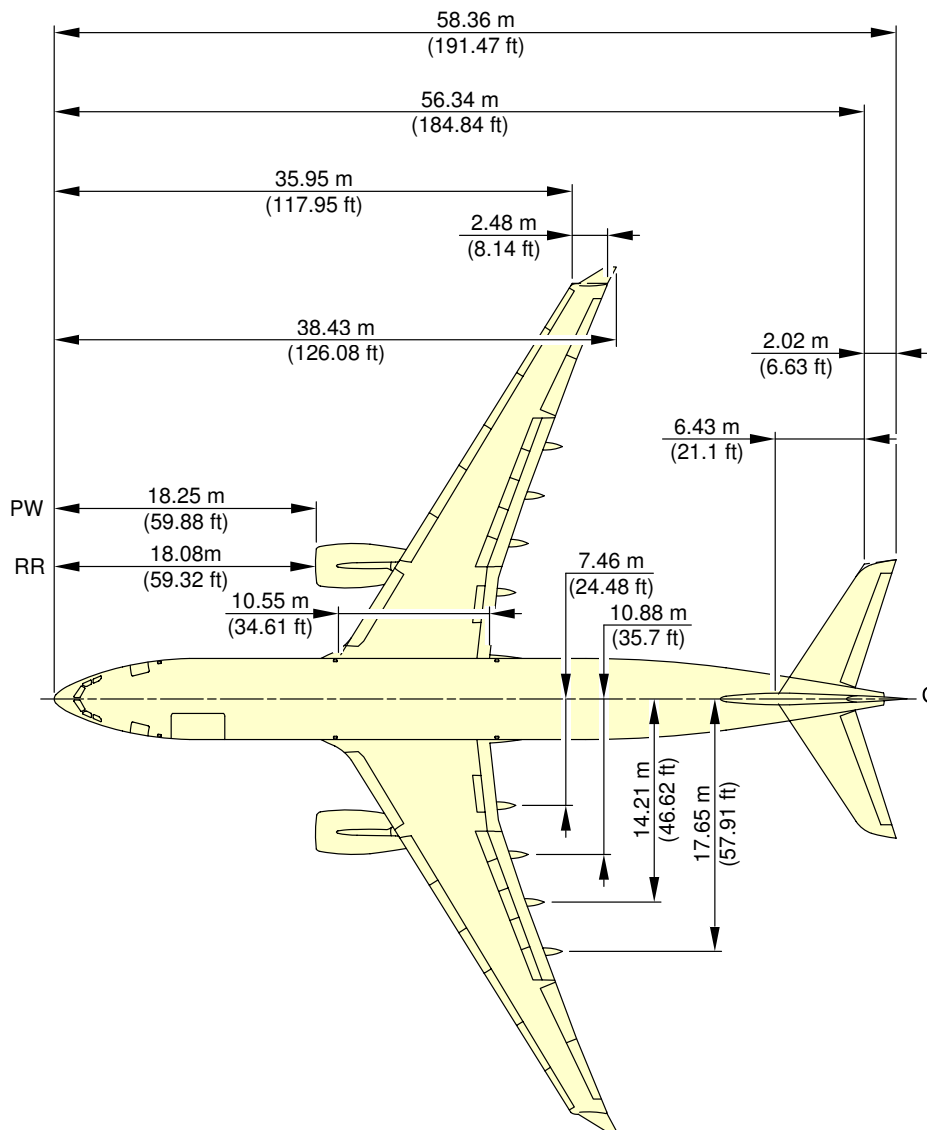

NOTE:
RELATED TO AIRCRAFT ATTITUDE AND WEIGHT.

F_AC_020200_1_0030102_01_00

General Aircraft Dimensions
(Sheet 2 of 2)
FIGURE-2-2-0-991-003-A01

2-3-0 Ground Clearances****ON A/C A330-200 A330-200F A330-300 A330-800 A330-900**Ground Clearances

1. This section gives the height of various points of the aircraft, above the ground, for different aircraft configurations.
Dimensions in the tables are approximate and will vary with tire type, weight and balance and other special conditions.

The dimensions are given for:

- A light weight, for an A/C in maintenance configuration with a mid CG,
- An aircraft at Maximum Ramp Weight with a FWD CG and an AFT CG,
- Aircraft on jacks, FDL at 6.50 m (21.33 ft).

NOTE : Passenger and cargo door ground clearances are measured from the center of the door sill and from floor level.

****ON A/C A330-300**

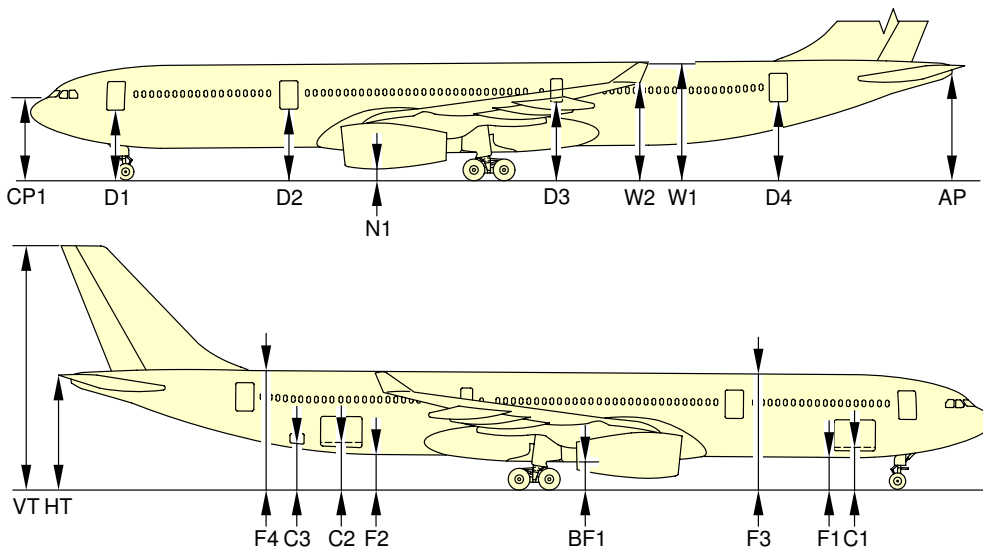

A/C CONFIGURATION	MRW				119 000 kg (262 350 lb)		A/C JACKED FDL = 6.50 m (21.33 ft)		
	FWD CG		AFT CG		MID CG		m	ft	
	m	ft	m	ft	m	ft			
DOORS	D1	4.41	14.46	4.55	14.92	4.55	14.92	6.32	20.73
	D2	4.67	15.32	4.73	15.51	4.83	15.84	6.32	20.73
	D3	5.31	17.42	5.20	17.06	5.34	17.52	6.43	21.10
	D4	5.55	18.20	5.41	17.75	5.77	18.93	6.53	21.42
	C1	2.55	8.36	2.66	8.72	2.70	8.85	4.14	13.58
	C2	3.22	10.56	3.13	10.27	3.43	11.25	4.24	13.91
FUSELAGE	C3	3.46	11.35	3.35	11.00	3.68	12.07	4.39	14.40
	F1	2.10	6.88	2.14	7.02	2.28	7.48	3.68	12.07
	F2	2.54	8.33	2.45	8.03	2.74	8.99	3.68	12.07
	F3	7.58	24.86	7.67	25.16	7.74	25.40	9.32	30.58
	F4	8.31	27.26	8.19	26.87	8.53	28.00	9.32	30.58
	BF1	1.86	6.10	1.85	6.07	2.04	6.70	3.26	10.70
WINGS	CP1	5.22	17.12	5.43	17.81	5.41	17.75	7.10	23.30
	W1	7.70	25.26	7.61	24.96	8.05	26.41	8.96	29.40
TAILPLANE	W2	6.13	20.11	6.06	19.88	6.46	21.20	7.55	24.77
	HT	8.09	26.54	7.88	25.85	8.33	27.32	9.23	30.28
	AP	7.24	23.76	7.03	23.06	7.48	24.54	8.10	26.57
ENGINE/ NACELLE	VT	16.94	55.58	16.72	54.85	17.18	56.36	17.62	57.81
	N1 (GE)	0.76	2.49	0.79	2.59	0.94	3.08	2.34	7.67
	N1 (PW)	0.72	2.36	0.75	2.46	0.90	2.95	2.29	7.51
	N1 (RR)	0.69	2.26	0.72	2.36	0.87	2.85	2.21	7.25

NOTE:

PASSENGER AND CARGO DOOR GROUND CLEARANCES ARE MEASURED FROM THE CENTER OF THE DOOR SILL AND FROM FLOOR LEVEL.

THE VALUES GIVEN IN THE TABLE DEPEND ON THE POSITION OF THE CENTER OF GRAVITY (CG) AND ON THE AIRCRAFT WEIGHT.

F_AC_020300_1_0010101_01_05

Ground Clearances
FIGURE-2-3-0-991-001-A01

****ON A/C A330-200**

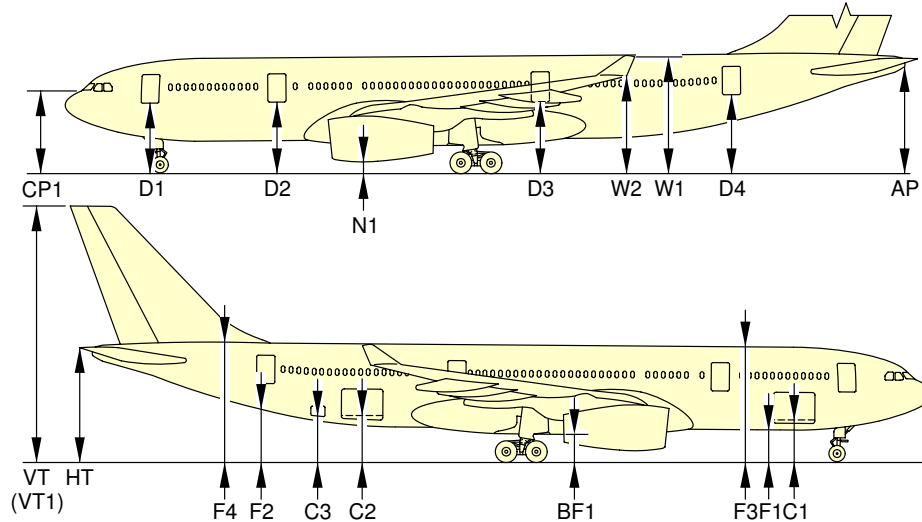

A/C CONFIGURATION		MRW						176 000 kg (388 013 lb)	
		FWD CG		AFT CG		MID CG		A/C JACKED FDL = 6.50 m (21.33 ft)	
		m	ft	m	ft	m	ft	m	ft
DOORS	D1	4.44	14.56	4.63	15.19	4.63	15.19	6.32	20.73
	D2	4.66	15.30	4.78	15.70	4.86	15.94	6.36	20.87
	D3	5.15	16.90	5.10	16.73	5.36	17.60	6.46	21.20
	D4	5.51	18.07	5.35	17.55	5.74	18.83	6.53	21.42
	C1	2.58	8.46	2.74	8.99	2.78	9.12	4.14	13.58
	C2	3.27	10.73	3.16	10.36	3.50	11.48	4.24	13.91
FUSELAGE	C3	3.43	11.25	3.30	10.82	3.66	12.01	4.39	14.40
	F1	2.03	6.66	2.12	6.95	2.23	7.31	3.68	12.07
	F2	2.48	8.13	2.40	7.87	2.70	8.86	3.68	12.07
	F3	7.56	24.80	7.69	25.23	7.75	25.42	9.32	30.58
	F4	8.31	27.26	8.16	26.77	8.54	28.02	9.32	30.58
	BF1	1.81	5.93	1.83	6.00	2.02	6.63	3.26	10.70
WINGS	CP1	5.22	17.12	5.43	17.81	5.41	17.75	7.10	23.30
	W1	7.71	25.29	7.61	24.96	8.08	26.51	8.96	29.40
TAILPLANE	W2	6.14	20.14	6.05	19.85	6.48	21.26	7.55	24.77
	HT	8.05	26.41	7.77	25.49	8.30	27.23	9.23	30.28
	AP	7.23	23.72	6.97	22.86	7.47	24.51	8.10	26.57
	VT	17.98	58.99	17.71	58.10	18.23	59.81	18.62	61.09
ENGINE/ NACELLE	VT1	17.48	57.35	17.21	56.46	17.73	58.17	18.12	59.45
	N1 (GE)	0.74	2.42	0.79	2.59	0.94	3.08	2.34	7.67
	N1 (PW)	0.70	2.29	0.75	2.46	0.90	2.95	2.29	7.51
	N1 (RR)	0.67	2.19	0.72	2.36	0.87	2.85	2.21	7.25

NOTE:

- VT1= POST MOD 48979 (SHORTER FIN INSTALLATION).
- PASSENGER AND CARGO DOOR GROUND CLEARANCES ARE MEASURED FROM THE CENTER OF THE DOOR SILL AND FROM FLOOR LEVEL.

THE VALUES GIVEN IN THE TABLE DEPEND ON THE POSITION OF THE CENTER OF GRAVITY (CG) AND ON THE AIRCRAFT WEIGHT.

F_AC_020300_1_0010202_01_03

Ground Clearances
FIGURE-2-3-0-991-001-B01

****ON A/C A330-200F**

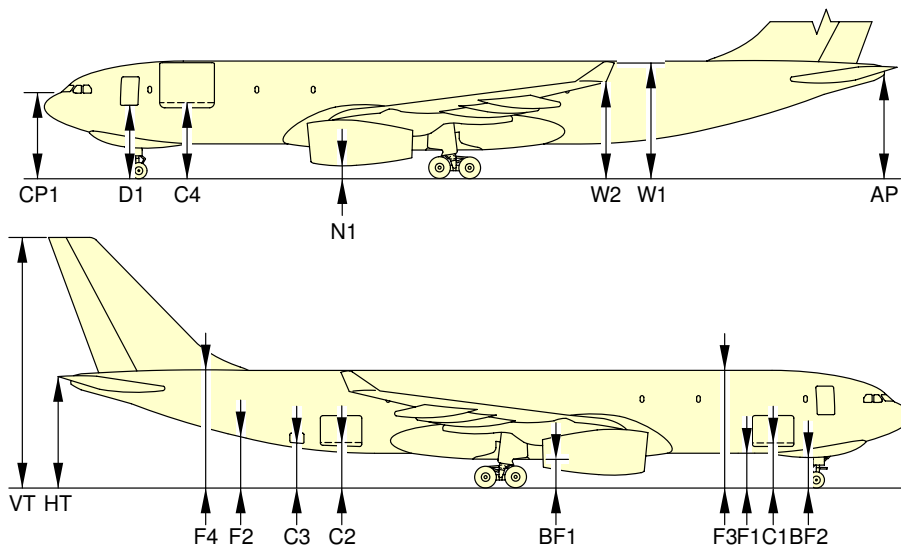

A/C CONFIGURATION		MRW				115 000 kg (253 531 lb)	
		FWD CG		AFT CG		MID CG	
		m	ft	m	ft	m	ft
DOORS	D1	4.82	15.81	5.00	16.40	4.98	16.34
	C1	2.93	9.61	3.08	10.10	3.11	10.20
	C2	3.15	10.33	3.04	9.97	3.52	11.55
	C4	4.88	16.01	5.03	16.50	5.06	16.60
FUSELAGE	F1	2.26	7.41	2.35	7.71	2.47	8.10
	F2	2.37	7.78	2.29	7.51	2.70	8.86
	F3	7.87	25.82	8.01	26.28	8.06	26.44
	F4	8.06	26.44	7.91	25.95	8.44	27.69
	BF1	1.89	6.20	1.91	6.27	2.16	7.09
	BF2	2.06	6.76	2.24	7.35	2.22	7.28
	CP1	6.08	19.95	6.29	20.64	6.22	20.41
WINGS	W1	8.88	29.13	8.78	28.81	9.23	30.28
	W2	7.46	24.48	7.36	24.15	7.80	25.59
TAILPLANE	HT	7.85	25.75	7.57	24.84	8.31	27.26
	AP	7.46	24.48	7.19	23.59	7.92	25.98
	VT	16.95	55.61	16.67	54.69	17.41	57.12
ENGINE/ NACELLE	N1 (PW)	0.89	2.92	0.95	3.12	1.13	3.71
	N1 (RR)	0.82	2.69	0.87	2.85	1.06	3.48

NOTE:

CREW AND CARGO DOOR GROUND CLEARANCES ARE MEASURED FROM THE CENTER OF THE DOOR SILL AND FROM FLOOR LEVEL.

THE VALUES GIVEN IN THE TABLE DEPEND ON THE POSITION OF THE CENTER OF GRAVITY (CG) AND ON THE AIRCRAFT WEIGHT.

F_AC_020300_1_0010301_01_03

Ground Clearances
FIGURE-2-3-0-991-001-C01

****ON A/C A330-900**

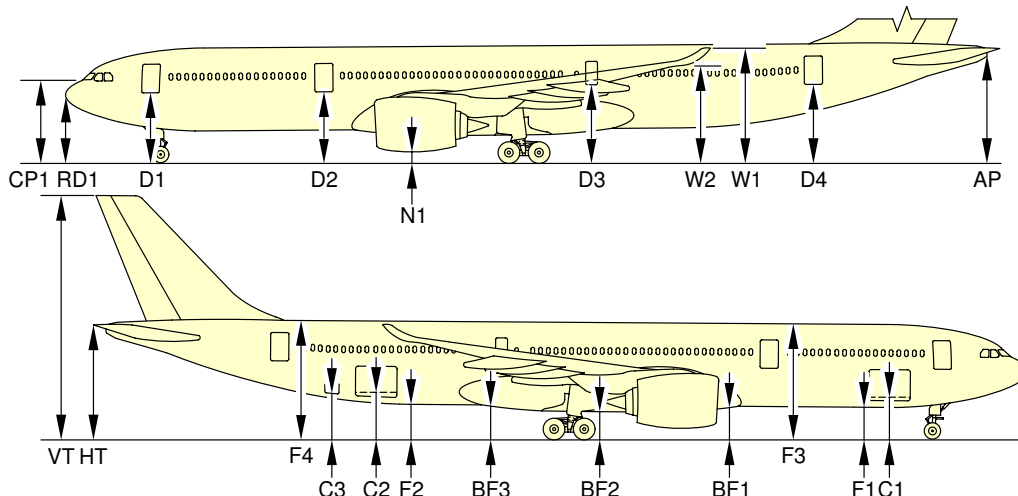

A/C CONFIGURATION		MRW 238 900 kg (526 684 lb)				140 000 kg (308 647 lb)				A/C JACKED	
		FWD CG (25%)		AFT CG (33.2%)		FWD CG (20%)		AFT CG (40%)		FDL = 6.5 m (21.33 ft)	
		m	ft	m	ft	m	ft	m	ft	m	ft
DOORS	D1	4.53	14.87	4.62	15.17	4.63	15.19	4.73	15.52	6.34	20.79
	D2	4.74	15.54	4.78	15.69	4.88	16.01	4.92	16.16	6.34	20.79
	D3	5.05	16.56	5.02	16.48	5.26	17.25	5.22	17.12	6.33	20.78
	D4	5.52	18.11	5.44	17.84	5.79	18.99	5.67	18.62	6.55	21.48
	C1	2.60	8.52	2.68	8.78	2.71	8.89	2.79	9.16	4.34	14.23
	C2	3.24	10.63	3.18	10.45	3.48	11.43	3.40	11.16	4.38	14.38
FUSELAGE	C3	3.31	10.84	3.24	10.62	3.56	11.69	3.46	11.37	4.40	14.43
	F1	1.96	6.44	2.04	6.68	2.08	6.83	2.16	7.08	3.68	12.06
	F2	2.49	8.18	2.45	8.02	2.73	8.95	2.66	8.72	3.68	12.06
	F3	7.70	25.25	7.75	25.42	7.83	25.70	7.89	25.87	9.33	30.60
	F4	8.27	27.13	8.19	26.89	8.53	28.00	8.43	27.65	9.33	30.60
	BF1	2.12	6.95	2.16	7.07	2.27	7.45	2.30	7.56	3.68	12.07
	BF2	1.86	6.10	1.86	6.10	2.05	6.71	2.03	6.68	3.26	10.70
	BF3	2.38	7.81	2.35	7.72	2.60	8.53	2.55	8.36	3.64	11.96
	CP1	5.36	17.58	5.47	17.94	5.44	17.84	5.56	18.25	7.24	23.75
WINGS	RD1	4.31	14.15	4.43	14.53	4.39	14.39	4.52	14.82	6.22	20.40
	W1	7.50	24.59	7.44	24.42	7.74	25.39	7.66	25.12	8.65	28.37
TAILPLANE	W2	6.14	20.15	6.10	20.03	6.37	20.88	6.31	20.69	7.37	24.18
	HT	8.07	26.49	7.95	26.08	8.39	27.52	8.22	26.97	8.91	29.23
ENGINE/ NACELLE	AP	7.49	24.59	7.37	24.17	7.81	25.63	7.64	25.06	8.32	27.29
	VT	16.81	55.16	16.68	54.73	17.13	56.20	16.95	55.63	17.62	57.82
ENGINE/ NACELLE	N1	0.67	2.18	0.69	2.27	0.83	2.72	0.85	2.78	2.17	7.13
	N1 WITH DRAIN MAST	0.64	2.10	0.66	2.17	0.80	2.62	0.82	2.69	2.14	7.02

NOTE:

PASSENGER AND CARGO DOOR GROUND CLEARANCES ARE MEASURED FROM THE CENTER OF THE DOOR SILL AND FROM FLOOR LEVEL.
 THE GROUND CLEARANCES ARE GIVEN FOR INDICATION ONLY. DISTANCES DEPEND ON MASS, CG AND AIRCRAFT CONFIGURATION.
 THE VALUES GIVEN IN THE TABLE DEPEND ON THE POSITION OF THE CENTER OF GRAVITY (CG) AND ON THE AIRCRAFT WEIGHT.

F_AC_020300_1_0350101_01_02

Ground Clearances
 FIGURE-2-3-0-991-035-A01

****ON A/C A330-800**

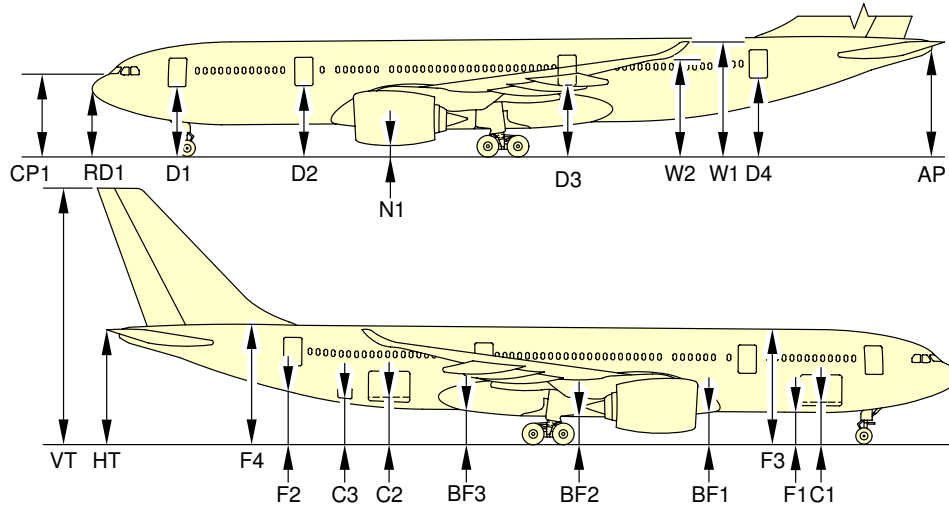

A/C CONFIGURATION		MRW 238 900 kg (526 684 lb)				135 000 kg (297 624 lb)				A/C JACKED	
		FWD CG (25%)		AFT CG (33.2%)		FWD CG (20%)		AFT CG (40%)		FDL = 6.5 m (21.33 ft)	
		m	ft	m	ft	m	ft	m	ft	m	ft
DOORS	D1	4.49	14.74	4.58	15.01	4.59	15.06	4.71	15.45	6.34	20.79
	D2	4.68	15.34	4.73	15.50	4.82	15.82	4.88	16.02	6.33	20.78
	D3	5.07	16.63	5.04	16.55	5.31	17.41	5.25	17.23	6.34	20.79
	D4	5.56	18.24	5.48	17.99	5.86	19.23	5.72	18.78	6.55	21.49
	C1	2.57	8.44	2.64	8.67	2.69	8.83	2.79	9.14	4.34	14.23
	C2	3.26	10.69	3.21	10.52	3.53	11.57	3.43	11.26	4.39	14.40
FUSELAGE	C3	3.32	10.90	3.26	10.70	3.61	11.83	3.49	11.46	4.39	14.40
	F1	1.95	6.39	2.01	6.59	2.07	6.80	2.16	7.08	3.68	12.06
	F2	2.49	8.18	2.45	8.05	2.75	9.02	2.67	8.76	3.68	12.06
	F3	7.63	25.04	7.69	25.22	7.77	25.48	7.84	25.72	9.33	30.60
	F4	8.30	27.25	8.23	27.01	8.60	28.21	8.47	27.79	9.33	30.60
	BF1	2.07	6.79	2.11	6.92	2.23	7.30	2.27	7.46	3.68	12.07
WINGS	BF2	1.85	6.07	1.85	6.08	2.05	6.74	2.04	6.70	3.26	10.70
	BF3	2.41	7.90	2.38	7.80	2.65	8.70	2.59	8.49	3.64	11.96
	CP1	5.30	17.38	5.40	17.72	5.37	17.63	5.52	18.12	7.24	23.75
	RD1	4.25	13.93	4.35	14.29	4.32	14.16	4.47	14.68	6.22	20.40
	W1	7.97	26.16	7.91	25.97	8.25	27.07	8.14	26.72	9.06	29.74
	W2	6.70	21.97	6.65	21.81	6.96	22.85	6.87	22.54	7.84	25.71
TAILPLANE	HT	8.26	27.11	8.14	26.69	8.63	28.31	8.41	27.59	8.98	29.47
	AP	7.77	25.48	7.64	25.07	8.13	26.67	7.91	25.96	8.50	27.88
	VT	17.92	58.79	17.79	58.36	18.29	60.00	18.06	59.27	18.62	61.09
ENGINE/ NACELLE	N1	0.65	2.12	0.67	2.20	0.82	2.69	0.85	2.77	2.18	7.14
	N1 WITH DRAIN MAST	0.62	2.03	0.65	2.12	0.79	2.60	0.82	2.69	2.16	7.07

NOTE:

PASSENGER AND CARGO DOOR GROUND CLEARANCES ARE MEASURED FROM THE CENTER OF THE DOOR SILL AND FROM FLOOR LEVEL.

THE GROUND CLEARANCES ARE GIVEN FOR INDICATION ONLY. DISTANCES DEPEND ON MASS, CG AND AIRCRAFT CONFIGURATION.

THE VALUES GIVEN IN THE TABLE DEPEND ON THE POSITION OF THE CENTER OF GRAVITY (CG) AND ON THE AIRCRAFT WEIGHT.

F_AC_020300_1_0360101_01_02

Ground Clearances
FIGURE-2-3-0-991-036-A01

**ON A/C A330-200 A330-200F A330-300

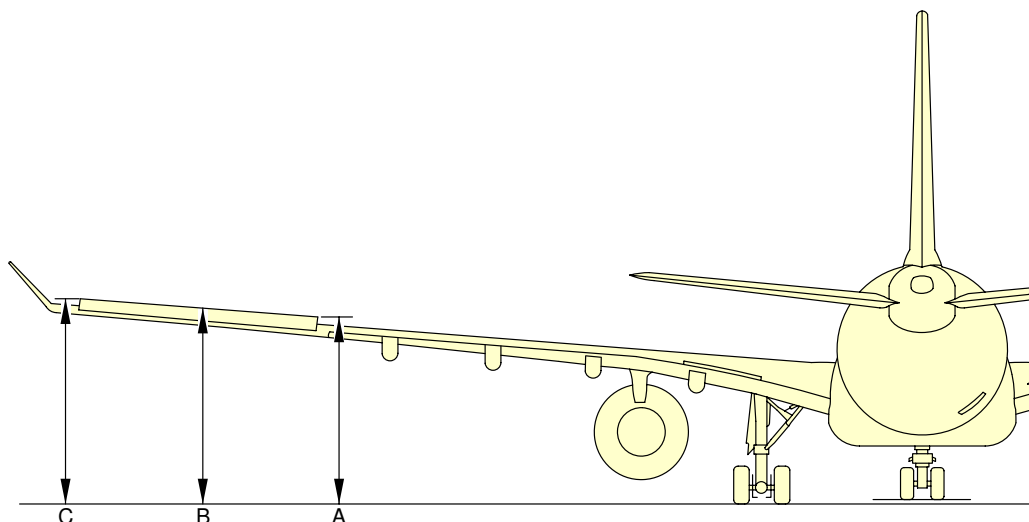

AILERONS UP							
DESCRIPTION		A/C IN MAINTENANCE CONFIGURATION MID CG		MRW FWD CG		MRW AFT CG	
		m	ft	m	ft	m	ft
AILERON 1 INBD	A	6.38	20.93	6.07	19.91	6.02	19.75
AILERON 1/2	B	6.58	21.59	6.26	20.54	6.20	20.34
AILERON 2 OUTBD	C	6.85	22.47	6.50	21.33	6.42	21.06

NOTE:

THE VALUES GIVEN IN THE TABLE DEPEND ON THE POSITION OF THE CENTER OF GRAVITY (CG) AND ON THE AIRCRAFT WEIGHT.

F_AC_020300_1_0150101_01_02

Ground Clearances
Ailerons – Up
FIGURE-2-3-0-991-015-A01

****ON A/C A330-800 A330-900**

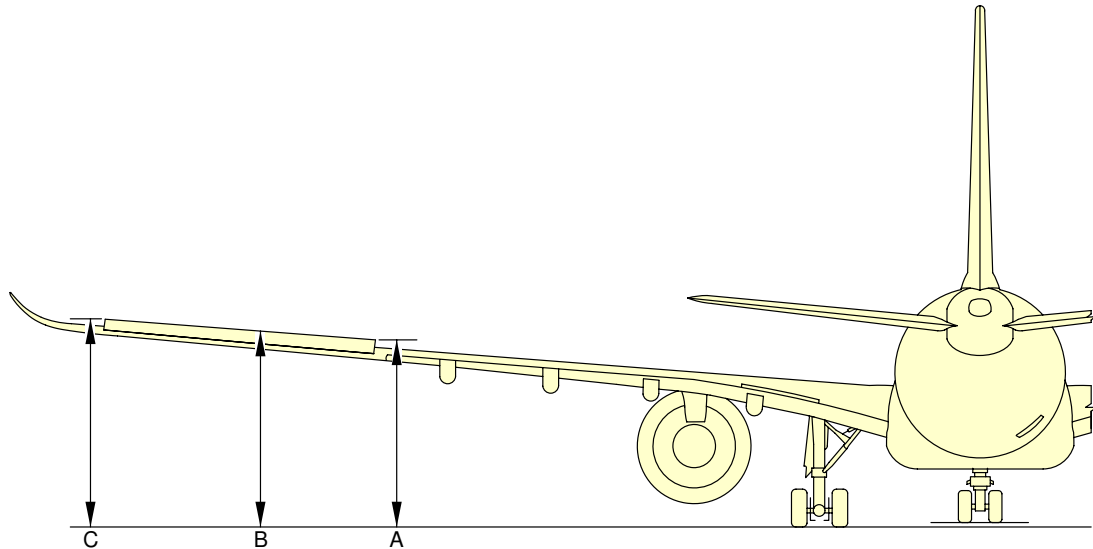

AILERONS UP						
AIRCRAFT TYPE	DESCRIPTION		MRW FWD CG		MRW AFT CG	
			m	ft	m	ft
01 A330-900	AILERON 1 INBD	A	6.21	20.37	6.18	20.28
	AILERON 1/2	B	6.40	21.00	6.36	20.87
	AILERON 2 OUTBD	C	6.64	21.78	6.58	21.59
01 A330-800	AILERON 1 INBD	A	6.17	20.24	6.16	20.21
	AILERON 1/2	B	6.36	20.87	6.34	20.80
	AILERON 2 OUTBD	C	6.60	21.65	6.56	21.52

NOTE:

THE VALUES GIVEN IN THE TABLE DEPEND ON THE POSITION OF THE CENTER OF GRAVITY (CG) AND ON THE AIRCRAFT WEIGHT.

01 THE GROUND CLEARANCES ARE GIVEN FOR INDICATION ONLY. DISTANCES DEPEND ON MASS, CG AND AIRCRAFT CONFIGURATION.

F_AC_020300_1_0400101_01_02

Ground Clearances
Ailerons – Up
FIGURE-2-3-0-991-040-A01

****ON A/C A330-200 A330-200F A330-300**

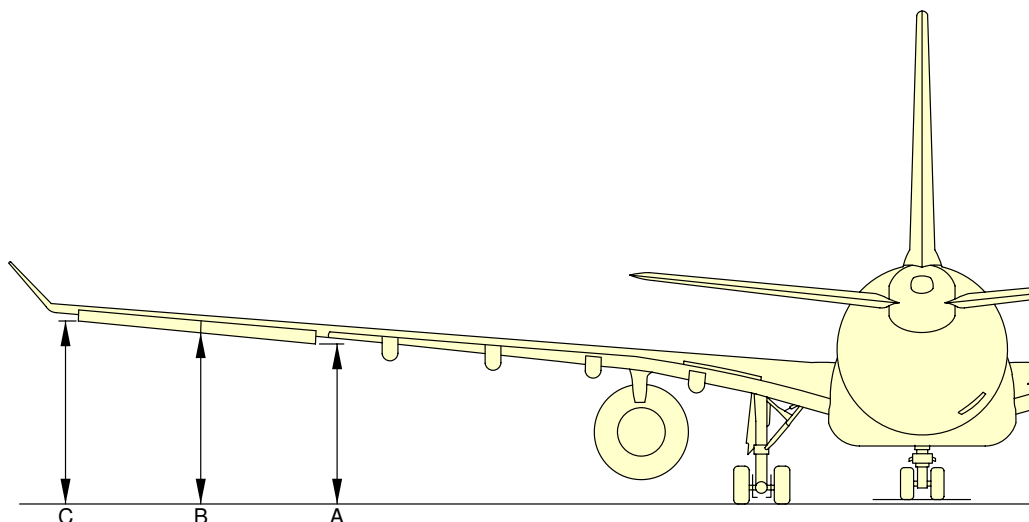

AILERONS DOWN							
DESCRIPTION		A/C IN MAINTENANCE CONFIGURATION MID CG		MRW FWD CG		MRW AFT CG	
		m	ft	m	ft	m	ft
AILERON 1 INBD	A	5.47	17.95	5.17	16.96	5.11	16.77
AILERON 1/2	B	5.83	19.13	5.51	18.08	5.44	17.85
AILERON 2 OUTBD	C	6.30	20.67	5.94	19.49	5.87	19.26

NOTE:

THE VALUES GIVEN IN THE TABLE DEPEND ON THE POSITION OF THE CENTER OF GRAVITY (CG) AND ON THE AIRCRAFT WEIGHT.

F_AC_020300_1_0160101_01_02

Ground Clearances
Ailerons – Down
FIGURE-2-3-0-991-016-A01

**ON A/C A330-800 A330-900

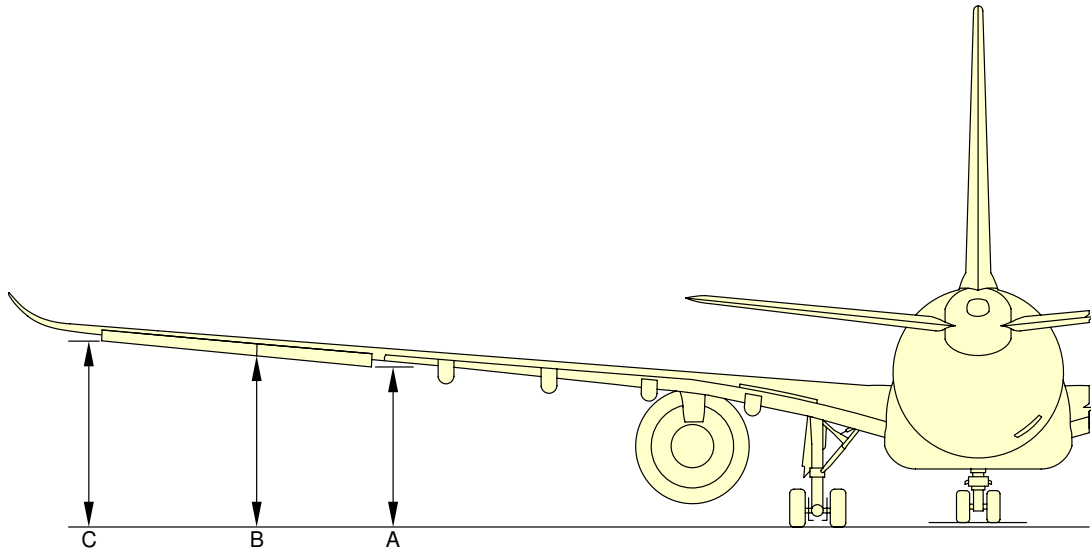

AILERONS DOWN						
AIRCRAFT TYPE	DESCRIPTION		MRW FWD CG		MRW AFT CG	
			m	ft	m	ft
01 A330-900	AILERON 1 INBD	A	5.31	17.42	5.27	17.29
	AILERON 1/2	B	5.65	18.54	5.60	18.37
	AILERON 2 OUTBD	C	6.08	19.95	6.03	19.78
01 A330-800	AILERON 1 INBD	A	5.27	17.29	5.25	17.22
	AILERON 1/2	B	5.61	18.41	5.58	18.31
	AILERON 2 OUTBD	C	6.04	19.82	6.01	19.72

NOTE:

THE VALUES GIVEN IN THE TABLE DEPEND ON THE POSITION OF THE CENTER OF GRAVITY (CG) AND ON THE AIRCRAFT WEIGHT.

01 THE GROUND CLEARANCES ARE GIVEN FOR INDICATION ONLY. DISTANCES DEPEND ON MASS, CG AND AIRCRAFT CONFIGURATION.

F_AC_020300_1_0410101_01_02

Ground Clearances
Ailerons – Down
FIGURE-2-3-0-991-041-A01

****ON A/C A330-200 A330-200F A330-300**

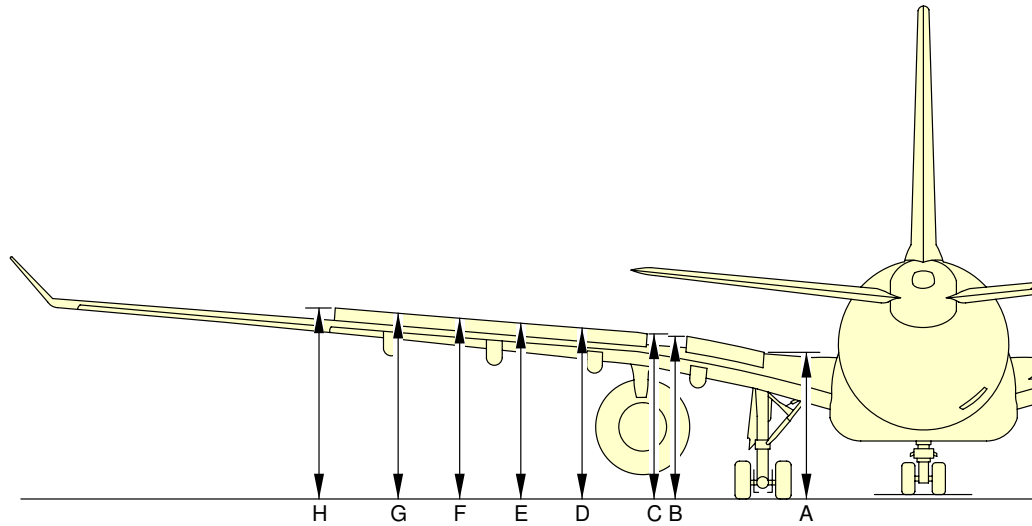

SPOILERS EXTENDED							
DESCRIPTION		A/C IN MAINTENANCE CONFIGURATION MID CG		MRW FWD CG		MRW AFT CG	
		m	ft	m	ft	m	ft
SPOILER 1 INBD	A	4.76	15.62	4.58	15.03	4.55	14.93
SPOILER 1 OUTBD	B	5.31	17.42	5.10	16.73	5.07	16.63
SPOILER 2 INBD	C	5.72	18.77	5.51	18.08	5.48	17.98
SPOILER 2/3	D	5.93	19.46	5.71	18.73	5.68	18.64
SPOILER 3/4	E	6.12	20.08	5.89	19.32	5.86	19.23
SPOILER 4/5	F	6.29	20.64	6.04	19.82	6.00	19.69
SPOILER 5/6	G	6.44	21.13	6.18	20.28	6.13	20.11
SPOILER 6 OUTBD	H	6.60	21.65	6.31	20.70	6.26	20.54

NOTE:

THE VALUES GIVEN IN THE TABLE DEPEND ON THE POSITION OF THE CENTER OF GRAVITY (CG) AND ON THE AIRCRAFT WEIGHT.

F_AC_020300_1_0170101_01_02

Ground Clearances
Spoilers – Extended
FIGURE-2-3-0-991-017-A01

**ON A/C A330-800 A330-900

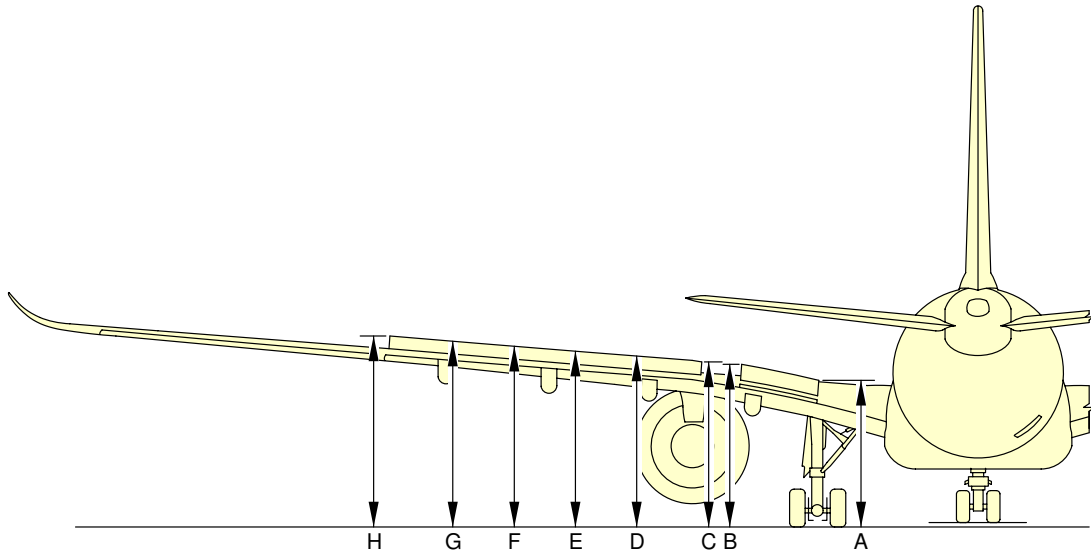

SPOILERS EXTENDED						
AIRCRAFT TYPE	DESCRIPTION		MRW FWD CG		MRW AFT CG	
			m	ft	m	ft
01 A330-900	SPOILER 1 INBD	A	4.72	15.49	4.71	15.45
	SPOILER 1 OUTBD	B	5.24	17.19	5.23	17.16
	SPOILER 2 INBD	C	5.65	18.54	5.64	18.50
	SPOILER 2/3	D	5.85	19.19	5.84	19.16
	SPOILER 3/4	E	6.03	19.78	6.02	19.75
	SPOILER 4/5	F	6.18	20.28	6.16	20.21
	SPOILER 5/6	G	6.32	20.73	6.29	20.64
	SPOILER 6 OUTBD	H	6.45	21.16	6.42	21.06

NOTE:

THE VALUES GIVEN IN THE TABLE DEPEND ON THE POSITION OF THE CENTER OF GRAVITY (CG) AND ON THE AIRCRAFT WEIGHT.

01 THE GROUND CLEARANCES ARE GIVEN FOR INDICATION ONLY. DISTANCES DEPEND ON MASS, CG AND AIRCRAFT CONFIGURATION.

F_AC_020300_1_0420101_01_02

Ground Clearances
Spoilers – Extended (Sheet 1 of 2)
FIGURE-2-3-0-991-042-A01

**ON A/C A330-800 A330-900

SPOILERS EXTENDED						
AIRCRAFT TYPE	DESCRIPTION		MRW FWD CG		MRW AFT CG	
			m	ft	m	ft
01 A330-800	SPOILER 1 INBD	A	4.68	15.35	4.69	15.39
	SPOILER 1 OUTBD	B	5.20	17.06	5.21	17.09
	SPOILER 2 INBD	C	5.61	18.41	5.62	18.44
	SPOILER 2/3	D	5.81	19.06	5.82	19.09
	SPOILER 3/4	E	5.99	19.65	6.00	19.69
	SPOILER 4/5	F	6.14	20.14	6.14	20.14
	SPOILER 5/6	G	6.28	20.60	6.27	20.57
	SPOILER 6 OUTBD	H	6.41	21.03	6.40	21.00

NOTE:

THE VALUES GIVEN IN THE TABLE DEPEND ON THE POSITION OF THE CENTER OF GRAVITY (CG) AND ON THE AIRCRAFT WEIGHT.

01 THE GROUND CLEARANCES ARE GIVEN FOR INDICATION ONLY. DISTANCES DEPEND ON MASS, CG AND AIRCRAFT CONFIGURATION.

F_AC_020300_1_0420102_01_02

Ground Clearances
Spoilers – Extended (Sheet 2 of 2)
FIGURE-2-3-0-991-042-A01

****ON A/C A330-200 A330-200F A330-300**

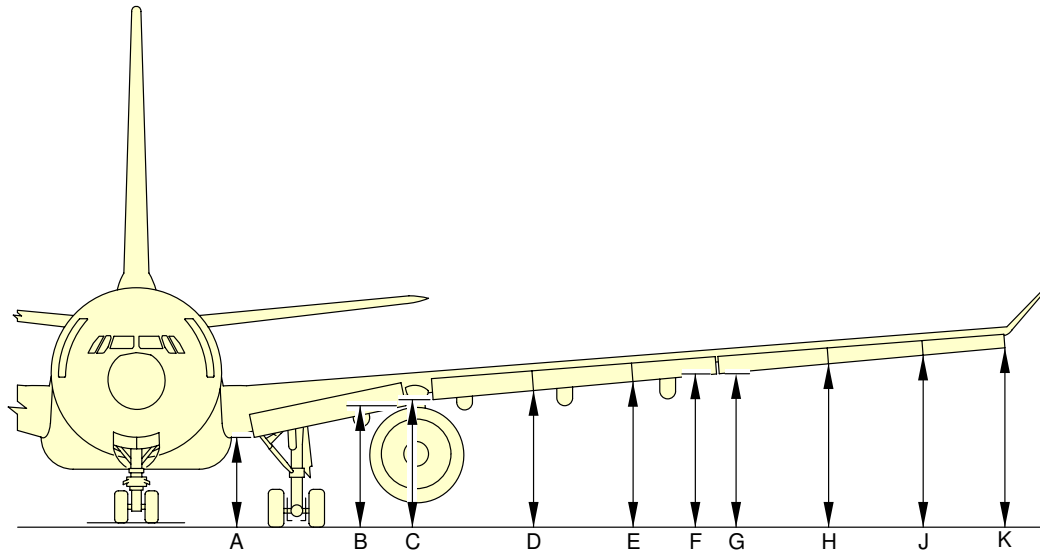

LEADING EDGE SLATS EXTENDED							
DESCRIPTION		A/C IN MAINTENANCE CONFIGURATION MID CG		MRW FWD CG		MRW AFT CG	
		m	ft	m	ft	m	ft
SLAT 1 INBD	A	3.46	11.35	3.28	10.76	3.31	10.86
SLAT 1 OUTBD	B	4.25	13.94	4.09	13.42	4.10	13.45
SLAT 2 INBD	C	4.28	14.04	4.10	13.45	4.11	13.48
SLAT 2/3	D	4.65	15.26	4.45	14.60	4.45	14.60
SLAT 3/4	E	4.99	16.37	4.77	15.65	4.76	15.62
SLAT 4 OUTBD	F	5.30	17.39	5.06	16.60	5.03	16.50
SLAT 5 INBD	G	5.37	17.62	5.12	16.80	5.09	16.70
SLAT 5/6	H	5.65	18.54	5.37	17.62	5.33	17.49
SLAT 6/7	J	5.91	19.39	5.61	18.41	5.56	18.24
SLAT 7 OUTBD	K	6.16	20.21	5.82	19.09	5.76	18.90

NOTE:

THE VALUES GIVEN IN THE TABLE DEPEND ON THE POSITION OF THE CENTER OF GRAVITY (CG) AND ON THE AIRCRAFT WEIGHT.

F_AC_020300_1_0180101_01_02

Ground Clearances
Leading Edge Slats – Extended
FIGURE-2-3-0-991-018-A01

****ON A/C A330-800 A330-900**

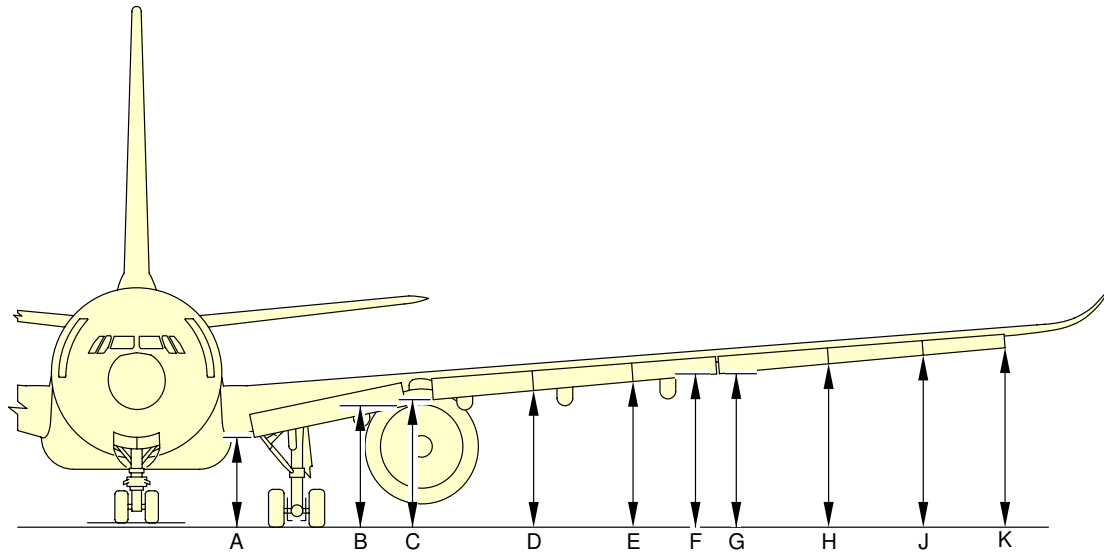

LEADING EDGE SLATS EXTENDED						
AIRCRAFT TYPE	DESCRIPTION		MRW FWD CG		MRW AFT CG	
			m	ft	m	ft
01 A330-900	SLAT 1 INBD	A	3.42	11.22	3.47	11.38
	SLAT 1 OUTBD	B	4.23	13.88	4.26	13.98
	SLAT 2 INBD	C	4.24	13.91	4.27	14.01
	SLAT 2/3	D	4.59	15.06	4.61	15.12
	SLAT 3/4	E	4.91	16.11	4.92	16.14
	SLAT 4 OUTBD	F	5.20	17.06	5.19	17.03
	SLAT 5 INBD	G	5.26	17.26	5.25	17.22
	SLAT 5/6	H	5.51	18.08	5.49	18.01
	SLAT 6/7	J	5.75	18.86	5.72	18.77
	SLAT 7 OUTBD	K	5.96	19.55	5.92	19.42

NOTE:

THE VALUES GIVEN IN THE TABLE DEPEND ON THE POSITION OF THE CENTER OF GRAVITY (CG) AND ON THE AIRCRAFT WEIGHT.

01 THE GROUND CLEARANCES ARE GIVEN FOR INDICATION ONLY. DISTANCES DEPEND ON MASS, CG AND AIRCRAFT CONFIGURATION.

F_AC_020300_1_0430101_01_02

Ground Clearances
Leading Edge Slats – Extended (Sheet 1 of 2)
FIGURE-2-3-0-991-043-A01

**ON A/C A330-800 A330-900

LEADING EDGE SLATS EXTENDED						
AIRCRAFT TYPE	DESCRIPTION		MRW FWD CG		MRW AFT CG	
			m	ft	m	ft
01 A330-800	SLAT 1 INBD	A	3.38	11.09	3.45	11.32
	SLAT 1 OUTBD	B	4.19	13.75	4.24	13.91
	SLAT 2 INBD	C	4.20	13.78	4.25	13.94
	SLAT 2/3	D	4.55	14.93	4.59	15.06
	SLAT 3/4	E	4.87	15.98	4.90	16.08
	SLAT 4 OUTBD	F	5.16	16.93	5.17	16.96
	SLAT 5 INBD	G	5.22	17.13	5.23	17.16
	SLAT 5/6	H	5.47	17.95	5.47	17.95
	SLAT 6/7	J	5.71	18.73	5.70	18.70
	SLAT 7 OUTBD	K	5.92	19.42	5.90	19.36

NOTE:

THE VALUES GIVEN IN THE TABLE DEPEND ON THE POSITION OF THE CENTER OF GRAVITY (CG) AND ON THE AIRCRAFT WEIGHT.

01 THE GROUND CLEARANCES ARE GIVEN FOR INDICATION ONLY. DISTANCES DEPEND ON MASS, CG AND AIRCRAFT CONFIGURATION.

F_AC_020300_1_0430102_01_02

Ground Clearances
 Leading Edge Slats – Extended (Sheet 2 of 2)
 FIGURE-2-3-0-991-043-A01

****ON A/C A330-200 A330-200F A330-300**

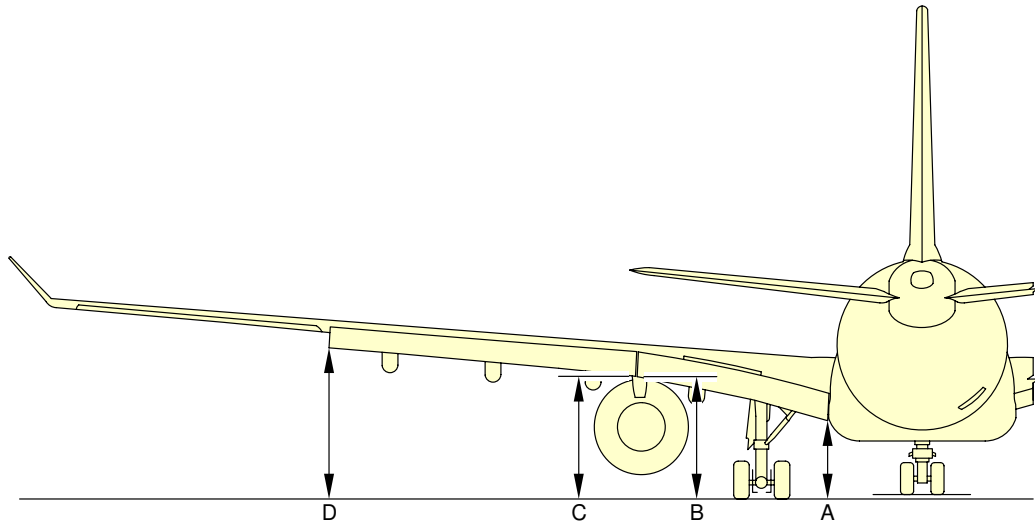

FLAPS EXTENDED							
DESCRIPTION		A/C IN MAINTENANCE CONFIGURATION MID CG		MRW FWD CG		MRW AFT CG	
		m	ft	m	ft	m	ft
FLAP 1 INBD	A	2.71	8.89	2.52	8.27	2.49	8.17
FLAP 1 OUTBD	B	4.00	13.12	3.80	12.47	3.76	12.34
FLAP 2 INBD	C	4.00	13.12	3.79	12.43	3.75	12.30
FLAP 2 OUTBD	D	5.21	17.09	4.91	16.11	4.85	15.91

NOTE:

THE VALUES GIVEN IN THE TABLE DEPEND ON THE POSITION OF THE CENTER OF GRAVITY (CG) AND ON THE AIRCRAFT WEIGHT.

F_AC_020300_1_0190101_01_02

Ground Clearances
Trailing Edge Flaps – Extended
FIGURE-2-3-0-991-019-A01

**ON A/C A330-800 A330-900

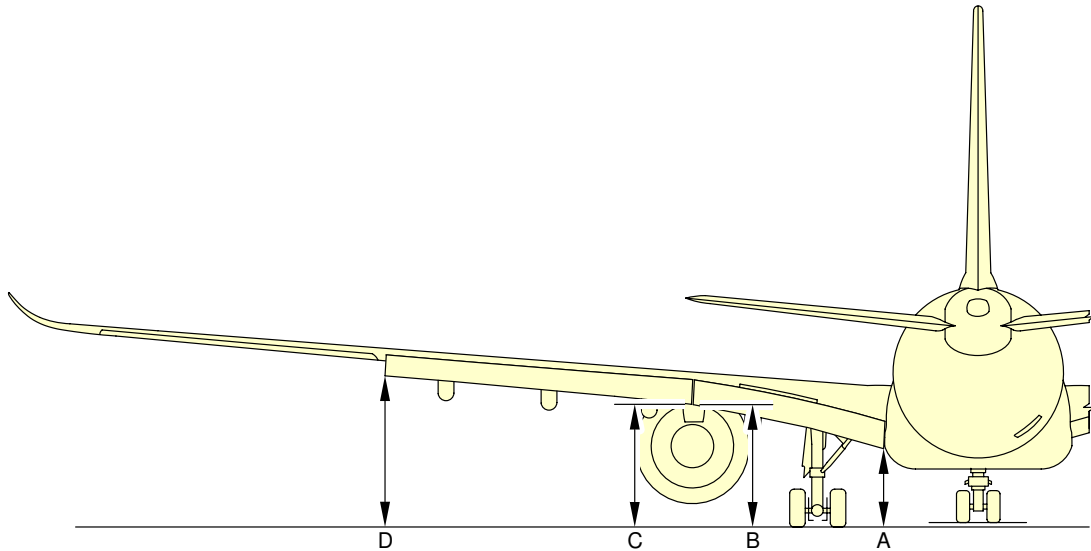

FLAPS EXTENDED						
AIRCRAFT TYPE	DESCRIPTION		MRW FWD CG		MRW AFT CG	
			m	ft	m	ft
01 A330-900	FLAP 1 INBD	A	2.66	8.73	2.65	8.69
	FLAP 1 OUTBD	B	3.94	12.93	3.92	12.86
	FLAP 2 INBD	C	3.93	12.89	3.91	12.83
	FLAP 2 OUTBD	D	5.05	16.57	5.01	16.44
01 A330-800	FLAP 1 INBD	A	2.62	8.60	2.63	8.63
	FLAP 1 OUTBD	B	3.90	12.80	3.90	12.80
	FLAP 2 INBD	C	3.89	12.76	3.89	12.76
	FLAP 2 OUTBD	D	5.01	16.44	4.99	16.37

NOTE:

THE VALUES GIVEN IN THE TABLE DEPEND ON THE POSITION OF THE CENTER OF GRAVITY (CG) AND ON THE AIRCRAFT WEIGHT.

01 THE GROUND CLEARANCES ARE GIVEN FOR INDICATION ONLY. DISTANCES DEPEND ON MASS, CG AND AIRCRAFT CONFIGURATION.

F_AC_020300_1_0440101_01_02

Ground Clearances
Trailing Edge Flaps – Extended
FIGURE-2-3-0-991-044-A01

****ON A/C A330-200 A330-200F A330-300**

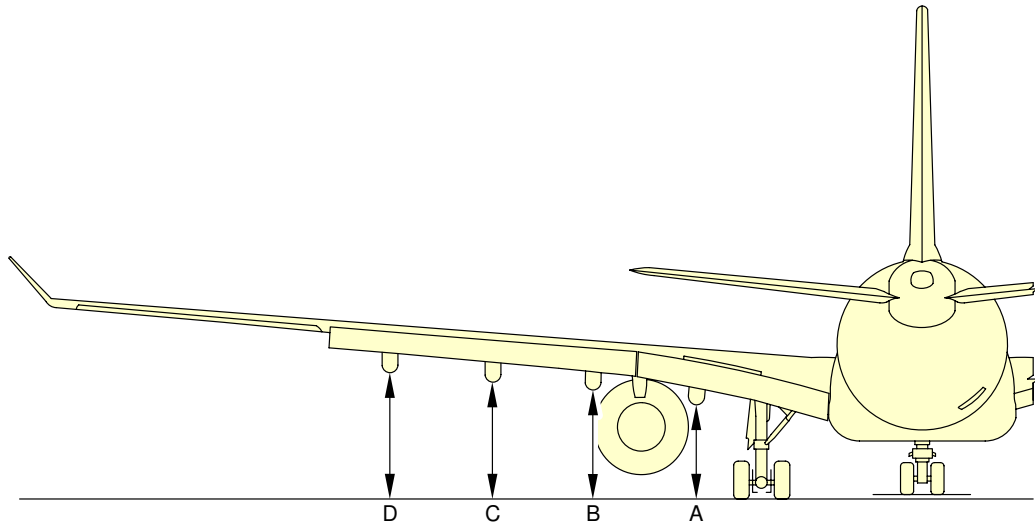

FLAP TRACKS EXTENDED							
DESCRIPTION		A/C IN MAINTENANCE CONFIGURATION MID CG		MRW FWD CG		MRW AFT CG	
		m	ft	m	ft	m	ft
FLAP TRACK 2	A	2.95	9.68	2.75	9.02	2.71	8.89
FLAP TRACK 3	B	3.48	11.42	3.29	10.79	3.24	10.63
FLAP TRACK 4	C	3.73	12.24	3.53	11.58	3.48	11.42
FLAP TRACK 5	D	4.08	13.39	3.88	12.73	3.82	12.53

NOTE:

THE VALUES GIVEN IN THE TABLE DEPEND ON THE POSITION OF THE CENTER OF GRAVITY (CG) AND ON THE AIRCRAFT WEIGHT.

F_AC_020300_1_0200101_01_02

Ground Clearances
Flap Tracks – Extended
FIGURE-2-3-0-991-020-A01

****ON A/C A330-800 A330-900**

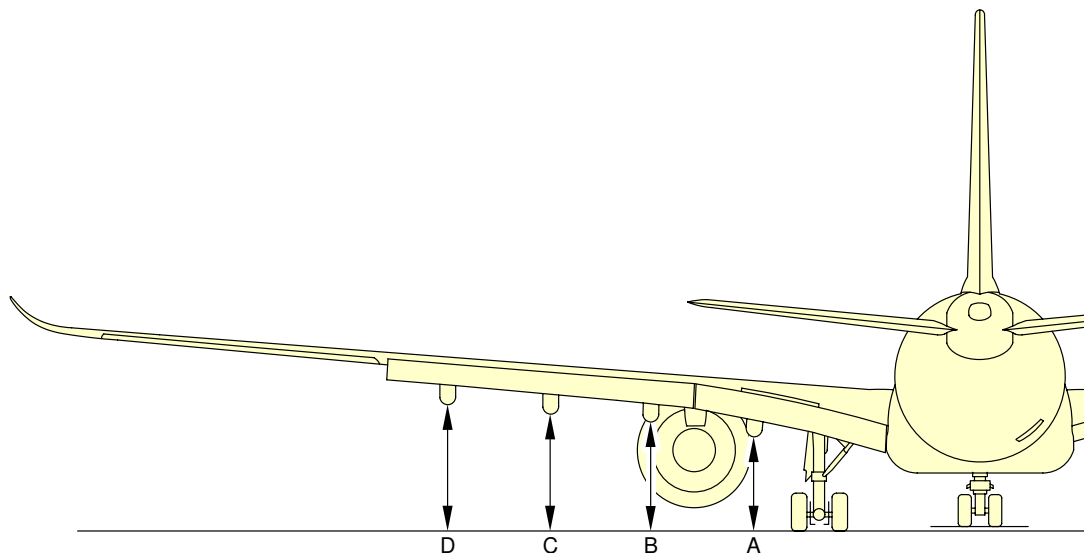

FLAP TRACKS EXTENDED						
AIRCRAFT TYPE	DESCRIPTION		MRW FWD CG		MRW AFT CG	
			m	ft	m	ft
01 A330-900	FLAP TRACK 2	A	2.80	9.19	2.79	9.15
	FLAP TRACK 3	B	3.43	11.25	3.38	11.09
	FLAP TRACK 4	C	3.71	12.17	3.67	12.04
	FLAP TRACK 5	D	4.07	13.35	4.03	13.22
01 A330-800	FLAP TRACK 2	A	2.77	9.09	2.75	9.02
	FLAP TRACK 3	B	3.35	10.99	3.31	10.86
	FLAP TRACK 4	C	3.62	11.88	3.60	11.81
	FLAP TRACK 5	D	4.12	13.52	4.10	13.45

NOTE:

THE VALUES GIVEN IN THE TABLE DEPEND ON THE POSITION OF THE CENTER OF GRAVITY (CG) AND ON THE AIRCRAFT WEIGHT.

01 THE GROUND CLEARANCES ARE GIVEN FOR INDICATION ONLY. DISTANCES DEPEND ON MASS, CG AND AIRCRAFT CONFIGURATION.

F_AC_020300_1_0370101_01_02

Ground Clearances
Flap Tracks – Extended
FIGURE-2-3-0-991-037-A01

****ON A/C A330-200 A330-200F A330-300**

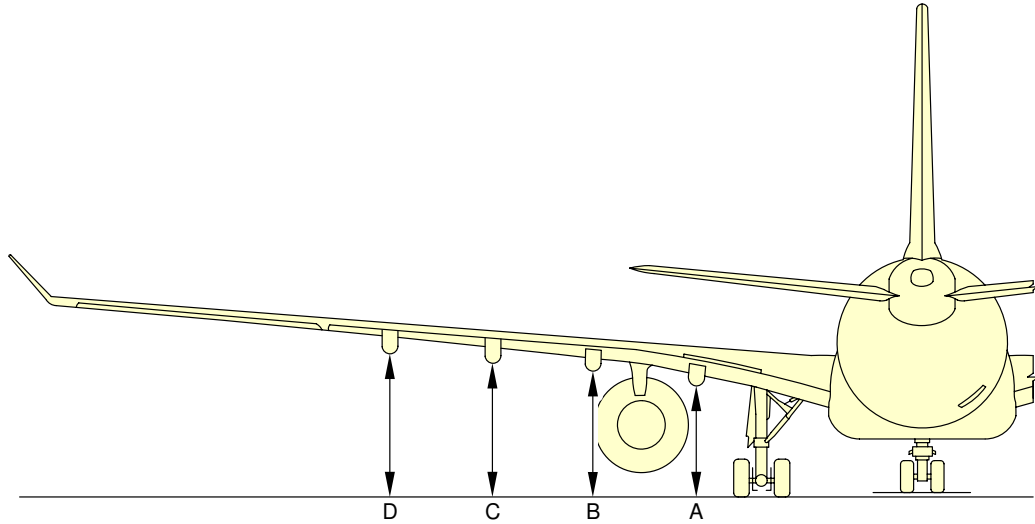

FLAP TRACKS RETRACTED								
AIRCRAFT TYPE	DESCRIPTION		A/C IN MAINTENANCE CONFIGURATION MID CG		MRW FWD CG		MRW AFT CG	
			m	ft	m	ft	m	ft
A330-300	FLAP TRACK 2	A	3.87	12.70	3.68	12.07	3.64	11.94
	FLAP TRACK 3	B	4.33	14.20	4.13	13.55	4.11	13.48
	FLAP TRACK 4	C	4.64	15.22	4.41	14.46	4.37	14.33
	FLAP TRACK 5	D	4.97	16.30	4.72	15.48	4.67	15.32
A330-200	FLAP TRACK 2	A	3.89	12.76	3.67	12.04	3.64	11.94
	FLAP TRACK 3	B	4.35	14.27	4.13	13.55	4.11	13.48
	FLAP TRACK 4	C	4.63	15.19	4.42	14.50	4.37	14.33
	FLAP TRACK 5	D	4.95	16.24	4.73	15.52	4.67	15.32
A330-200F	FLAP TRACK 2	A	2.74	8.99	2.44	8.00	2.41	7.89
	FLAP TRACK 3	B	2.98	9.79	2.69	8.83	2.67	8.75
	FLAP TRACK 4	C	2.92	9.59	2.63	8.62	2.60	8.53
	FLAP TRACK 5	D	3.02	9.91	2.70	8.86	2.64	8.66

NOTE:

THE VALUES GIVEN IN THE TABLE DEPEND ON THE POSITION OF THE CENTER OF GRAVITY (CG) AND ON THE AIRCRAFT WEIGHT.

F_AC_020300_1_0290101_01_01

Ground Clearances
Flap Tracks – Retracted
FIGURE-2-3-0-991-029-A01

****ON A/C A330-800 A330-900**

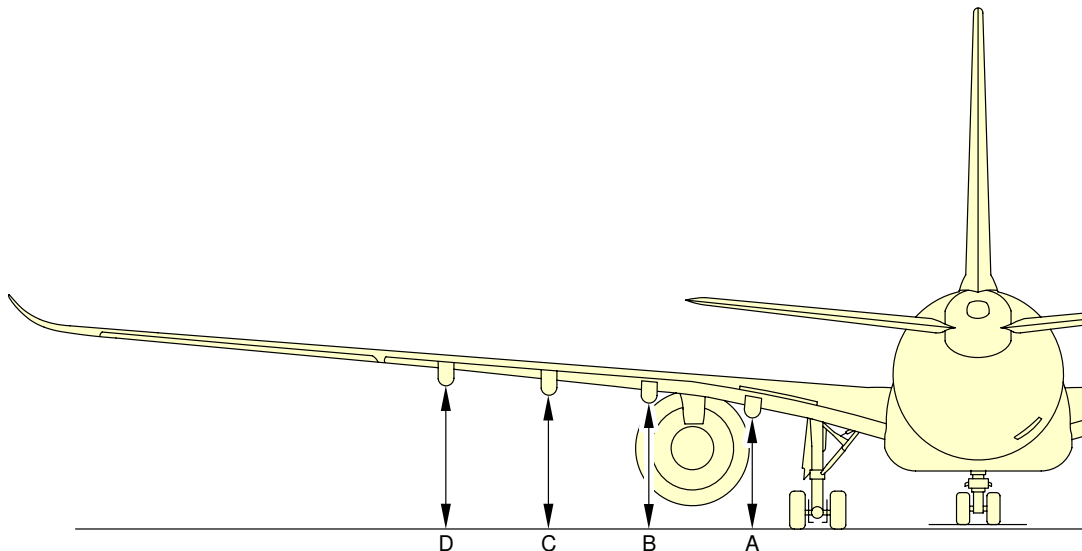

FLAP TRACKS RETRACTED						
AIRCRAFT TYPE	DESCRIPTION		MRW FWD CG		MRW AFT CG	
			m	ft	m	ft
01 A330-900	FLAP TRACK 2	A	3.73	12.25	3.72	12.20
	FLAP TRACK 3	B	4.27	14.00	4.25	13.95
	FLAP TRACK 4	C	4.59	15.05	4.56	14.97
	FLAP TRACK 5	D	4.91	16.11	4.88	16.02
01 A330-800	FLAP TRACK 2	A	3.69	12.11	3.68	12.08
	FLAP TRACK 3	B	4.19	13.76	4.18	13.72
	FLAP TRACK 4	C	4.51	14.79	4.49	14.73
	FLAP TRACK 5	D	4.97	16.32	4.95	16.24

NOTE:

THE VALUES GIVEN IN THE TABLE DEPEND ON THE POSITION OF THE CENTER OF GRAVITY (CG) AND ON THE AIRCRAFT WEIGHT.

01 THE GROUND CLEARANCES ARE GIVEN FOR INDICATION ONLY. DISTANCES DEPEND ON MASS, CG AND AIRCRAFT CONFIGURATION.

F_AC_020300_1_0380101_01_02

Ground Clearances
Flap Tracks – Retracted
FIGURE-2-3-0-991-038-A01

****ON A/C A330-200 A330-300**

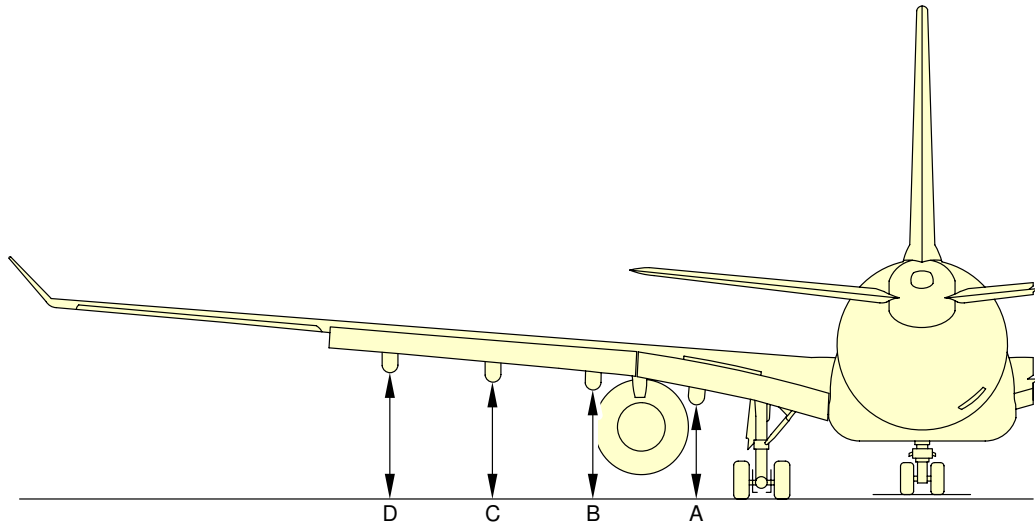

FLAP TRACKS 1+F								
AIRCRAFT TYPE	DESCRIPTION		A/C IN MAINTENANCE CONFIGURATION MID CG		MRW FWD CG		MRW AFT CG	
			m	ft	m	ft	m	ft
A330-300	FLAP TRACK 2	A	3.50	11.48	3.31	10.86	3.27	10.73
	FLAP TRACK 3	B	3.96	12.99	3.76	12.34	3.74	12.27
	FLAP TRACK 4	C	4.27	14.01	4.04	13.25	4.00	13.12
	FLAP TRACK 5	D	4.60	15.09	4.35	14.27	4.30	14.11
A330-200	FLAP TRACK 2	A	3.52	11.55	3.30	10.83	3.27	10.73
	FLAP TRACK 3	B	3.98	13.06	3.76	12.34	3.74	12.27
	FLAP TRACK 4	C	4.26	13.98	4.05	13.29	4.00	13.12
	FLAP TRACK 5	D	4.58	15.03	4.36	14.30	4.30	14.11

NOTE:

THE VALUES GIVEN IN THE TABLE DEPEND ON THE POSITION OF THE CENTER OF GRAVITY (CG) AND ON THE AIRCRAFT WEIGHT.

F_AC_020300_1_0320101_01_01

Ground Clearances
Flap Tracks - 1 + F
FIGURE-2-3-0-991-032-A01

****ON A/C A330-800 A330-900**

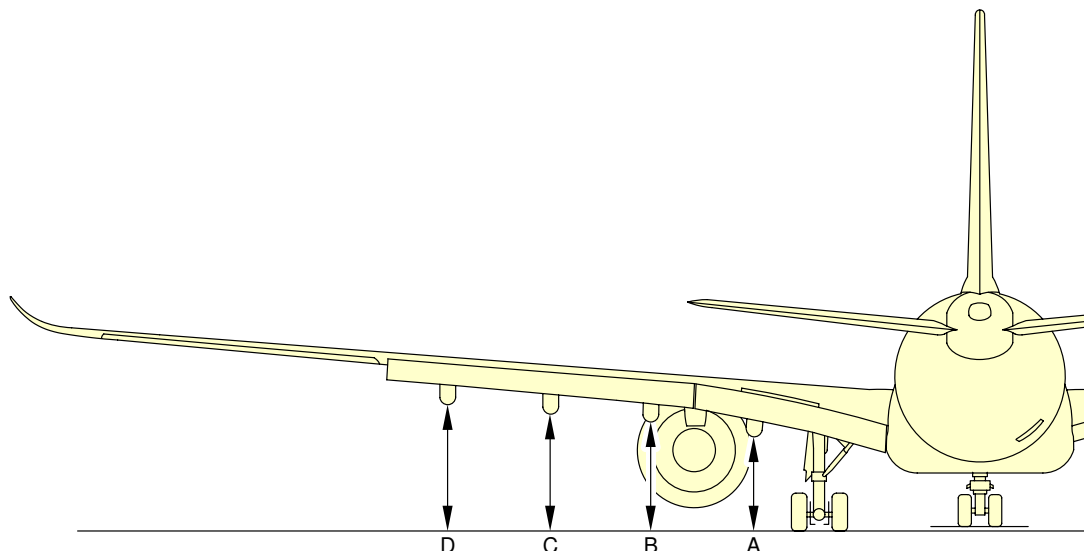

FLAP TRACKS 1+F						
AIRCRAFT TYPE	DESCRIPTION		MRW FWD CG		MRW AFT CG	
			m	ft	m	ft
01 A330-900	FLAP TRACK 2	A	3.36	11.02	3.35	10.99
	FLAP TRACK 3	B	3.90	12.80	3.88	12.73
	FLAP TRACK 4	C	4.22	13.85	4.19	13.75
	FLAP TRACK 5	D	4.54	14.90	4.51	14.80
01 A330-800	FLAP TRACK 2	A	3.32	10.89	3.31	10.86
	FLAP TRACK 3	B	3.82	12.53	3.81	12.50
	FLAP TRACK 4	C	4.14	13.58	4.12	13.52
	FLAP TRACK 5	D	4.60	15.09	4.58	15.03

NOTE:

THE VALUES GIVEN IN THE TABLE DEPEND ON THE POSITION OF THE CENTER OF GRAVITY (CG) AND ON THE AIRCRAFT WEIGHT.

01 THE GROUND CLEARANCES ARE GIVEN FOR INDICATION ONLY. DISTANCES DEPEND ON MASS, CG AND AIRCRAFT CONFIGURATION.

F_AC_020300_1_0390101_01_02

Ground Clearances
Flap Tracks - 1 + F
FIGURE-2-3-0-991-039-A01



2-4-1 Interior Arrangements - Plan View

**ON A/C A330-200 A330-300 A330-800 A330-900

Interior Arrangements - Plan View

1. This section provides the typical interior configuration.

**ON A/C A330-300 A330-900

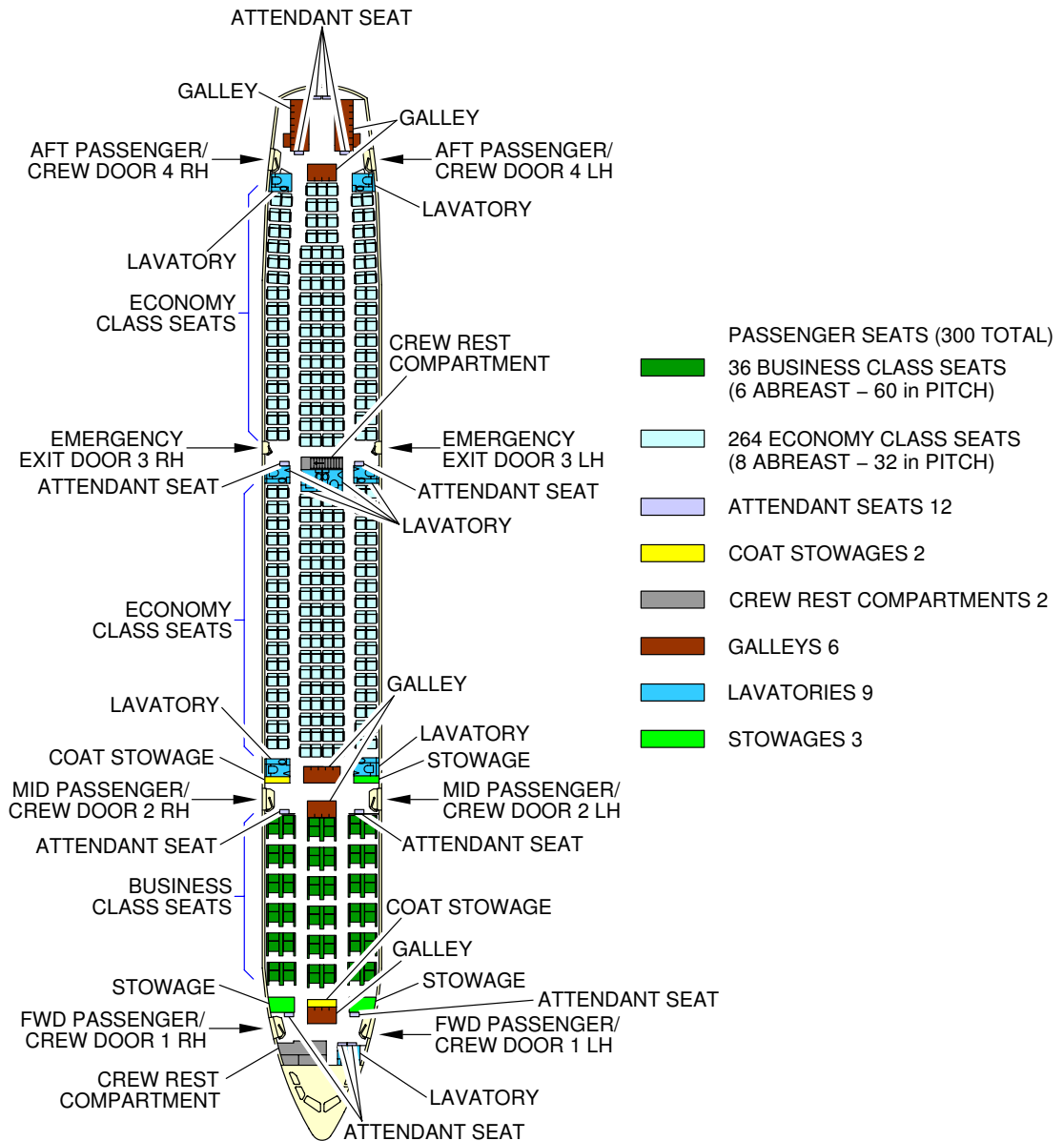

F_AC_020401_1_0010101_01_02

Interior Arrangements - Plan View
 Typical Configuration
 FIGURE-2-4-1-991-001-A01

**ON A/C A330-200 A330-800

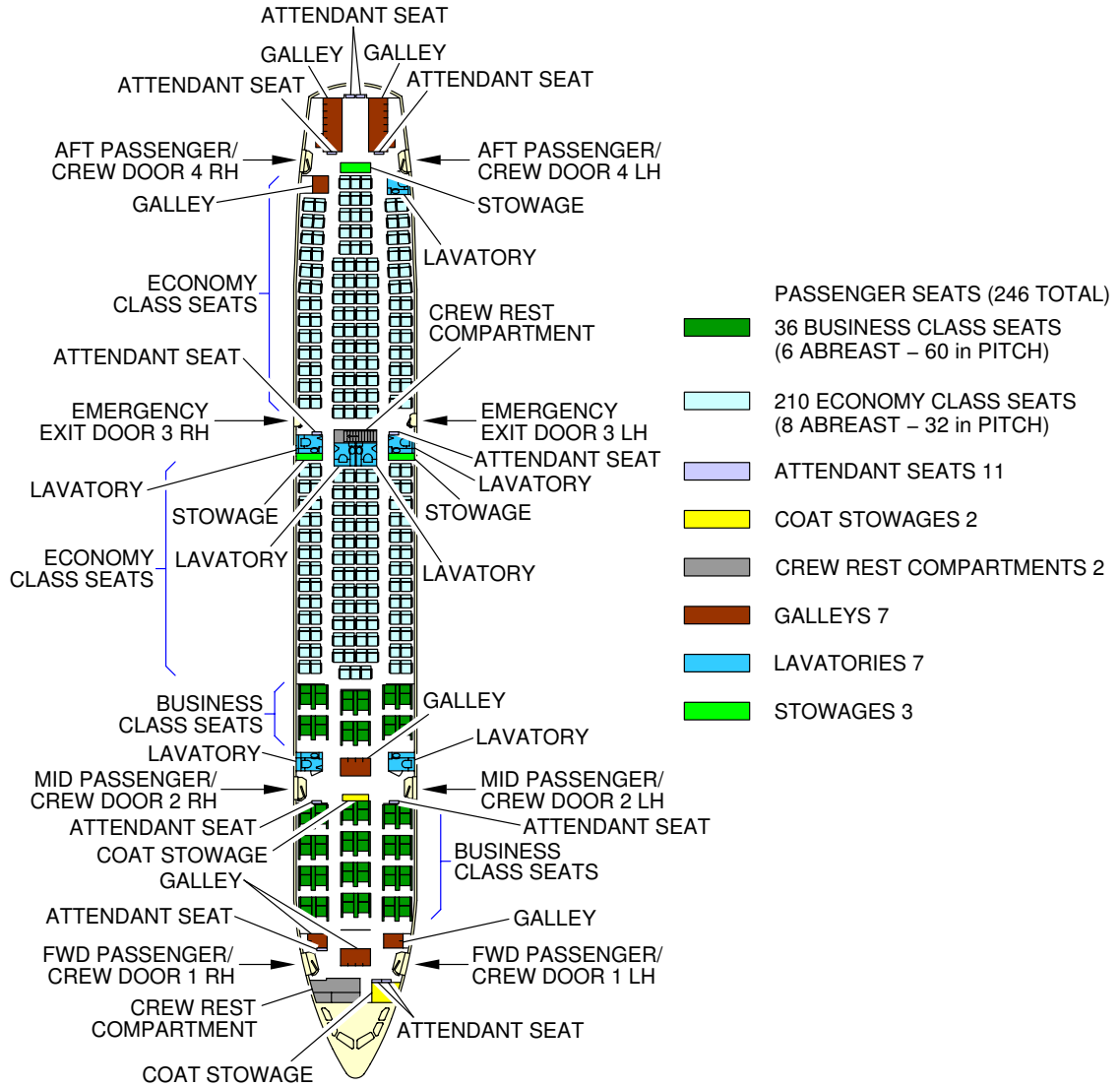

F_AC_020401_1_0020101_01_02

Interior Arrangements - Plan View
 Typical Configuration
 FIGURE-2-4-1-991-002-A01



2-5-0 Interior Arrangements - Cross Section

**ON A/C A330-200 A330-300 A330-800 A330-900

Interior Arrangements - Cross Section

1. This section gives the typical configuration of A330 pax version.

**ON A/C A330-200 A330-300 A330-800 A330-900

BUSINESS CLASS, 6 ABREAST

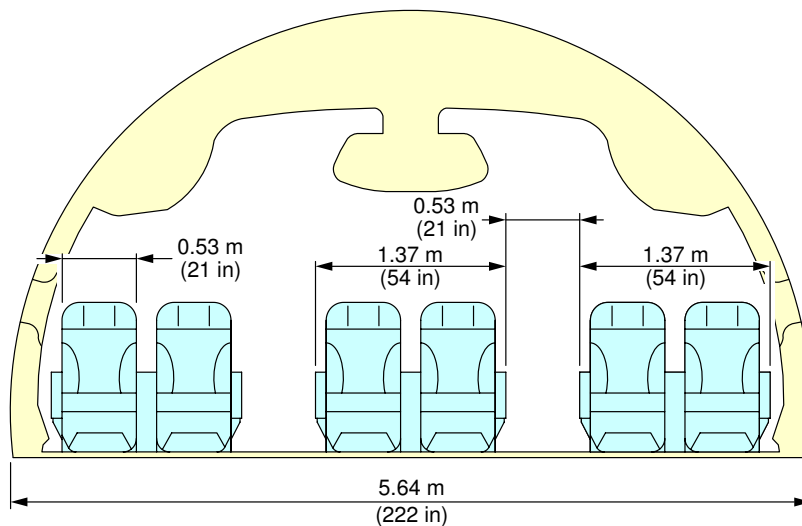

ECONOMY CLASS, 8 ABREAST

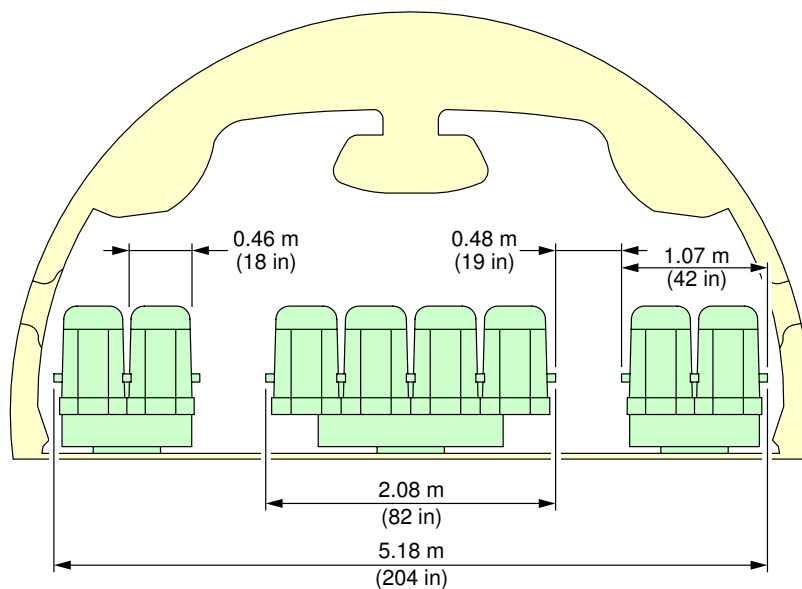

F_AC_020500_1_0010101_01_01

Interior Arrangements - Cross Section
Typical Configuration
FIGURE-2-5-0-991-001-A01



2-6-1 Lower Deck Cargo Compartments

****ON A/C A330-200 A330-200F A330-300 A330-800 A330-900**

Lower Deck Cargo Compartments

1. This section provides the following data about lower deck cargo compartments:
 - Location and dimensions
 - Loading combinations.

****ON A/C A330-200 A330-200F A330-300 A330-800 A330-900**

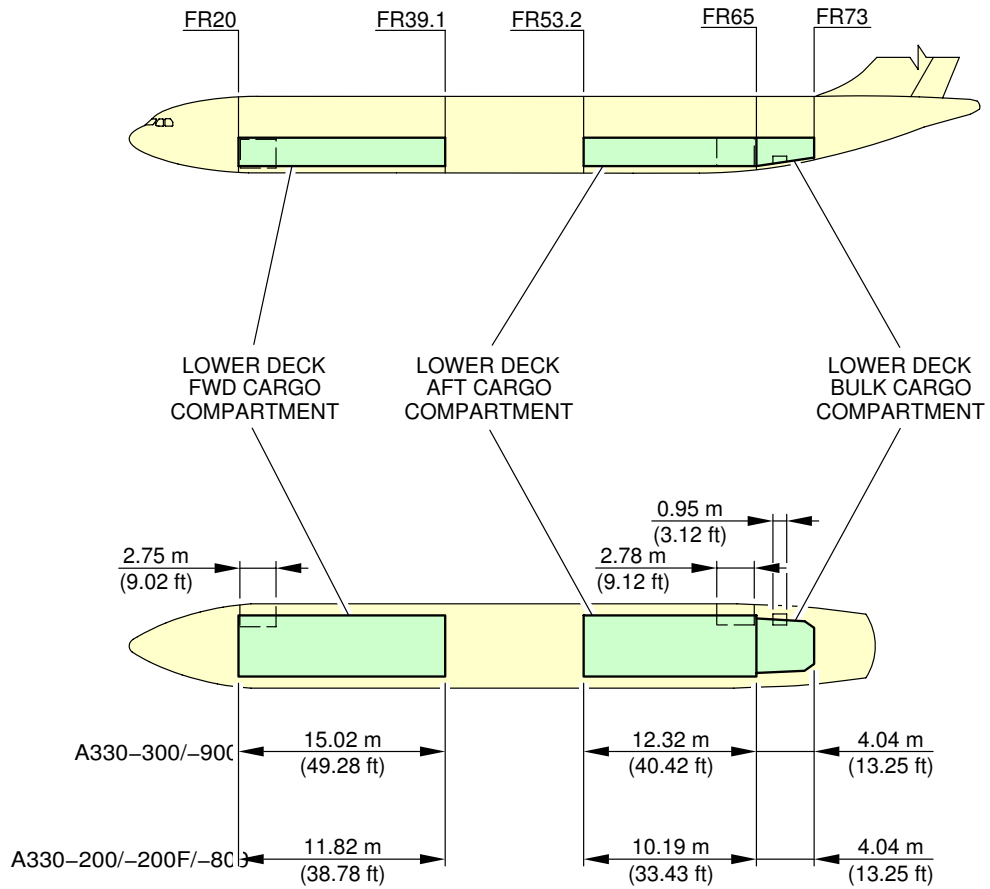

NOTE:
APPROXIMATE DIMENSIONS DEPENDING ON AIRCRAFT CONFIGURATION.

F_AC_020601_1_0030101_01_02

Lower Deck Cargo Compartments
Location and Dimensions
FIGURE-2-6-1-991-003-A01

**ON A/C A330-200 A330-200F A330-800

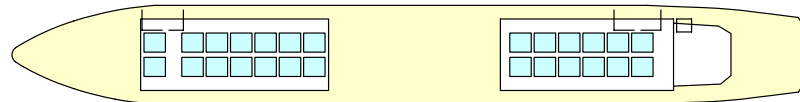

14 LD3 60.4 in X 61.5 in

12 LD3 60.4 in X 61.5 in

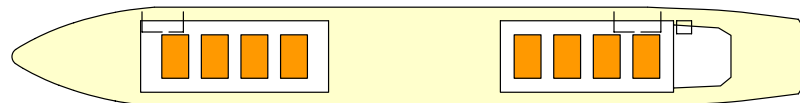

4 PALLETS 88 in X 125 in

4 PALLETS 88 in X 125 in

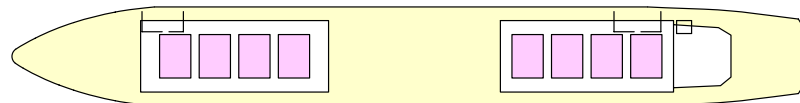

4 PALLETS 96 in X 125 in

4 PALLETS 96 in X 125 in

F_AC_020601_1_0040101_01_04

Lower Deck Cargo Compartments
Loading Combinations
FIGURE-2-6-1-991-004-A01

**ON A/C A330-300 A330-900

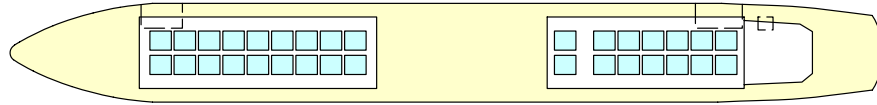

18 LD3 60.4 in X 61.5 in

14 LD3 60.4 in X 61.5 in

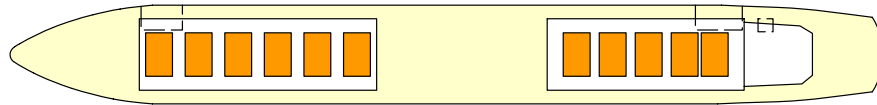

6 PALLETS 88 in X 125 in

5 PALLETS 88 in X 125 in

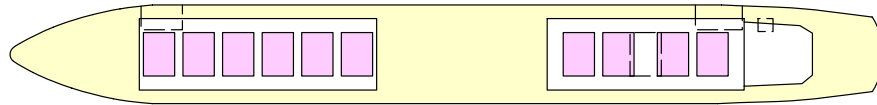

6 PALLETS 96 in X 125 in

4 PALLETS 96 in X 125 in

F_AC_020601_1_0040201_01_02

Lower Deck Cargo Compartments
Loading Combinations
FIGURE-2-6-1-991-004-B01

2-6-2 Main Deck Cargo Compartments

****ON A/C A330-200F**

Main Deck Cargo Compartment

1. This section gives the following data about the main deck cargo compartment:
 - Location and dimensions
 - Loading combinations.

****ON A/C A330-200F**

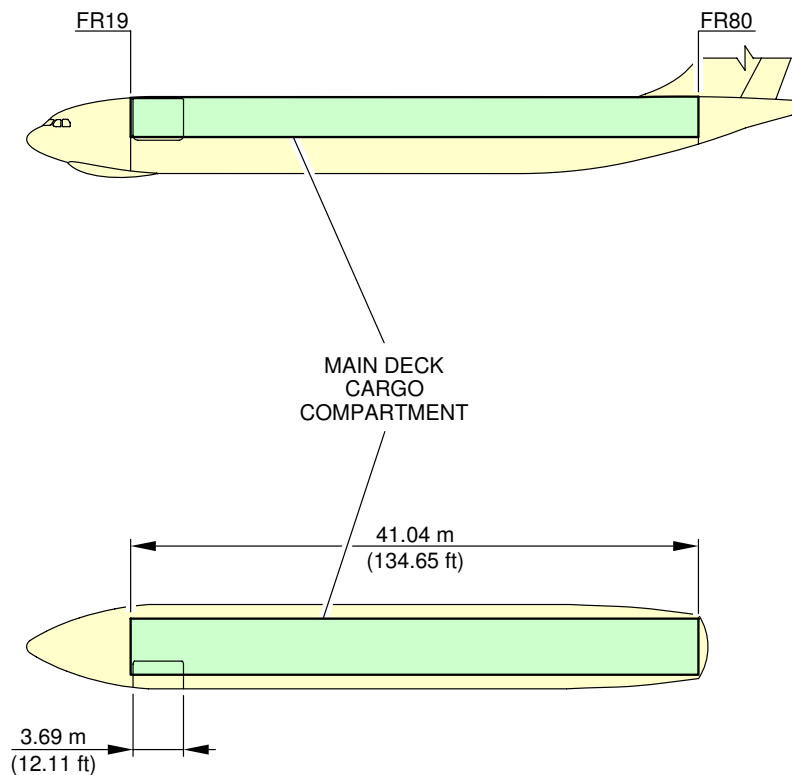

NOTE:
DEPENDENT ON A/C CONFIGURATION.

F_AC_020602_1_0060101_01_00

Main Deck Cargo Compartment
Location and Dimensions
FIGURE-2-6-2-991-006-A01

****ON A/C A330-200F**

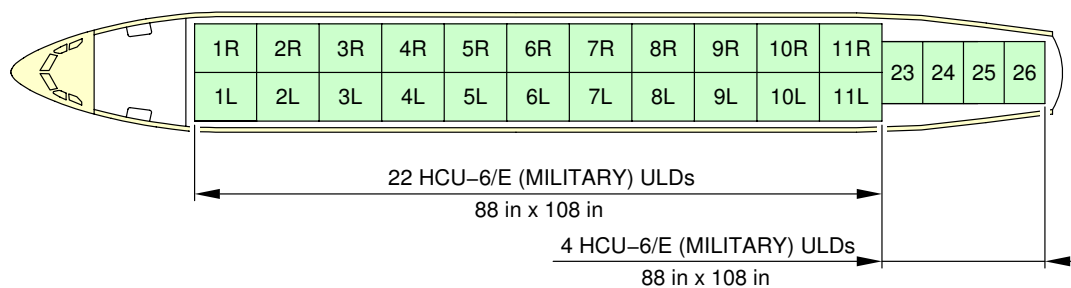
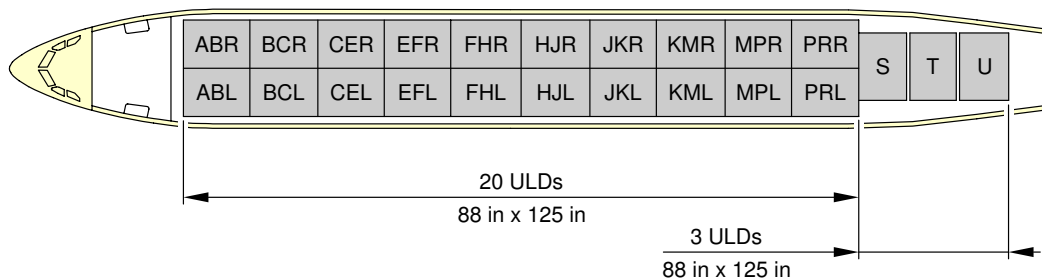
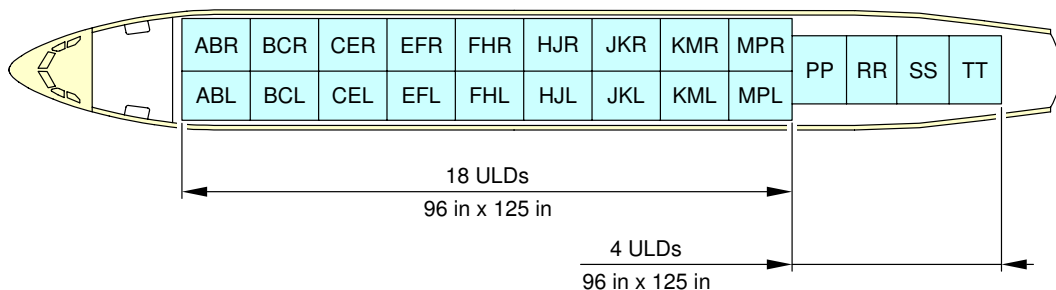

F_AC_020602_1_0010101_01_01

Main Deck Cargo Compartment
Loading Combinations
FIGURE-2-6-2-991-001-A01

**ON A/C A330-200F

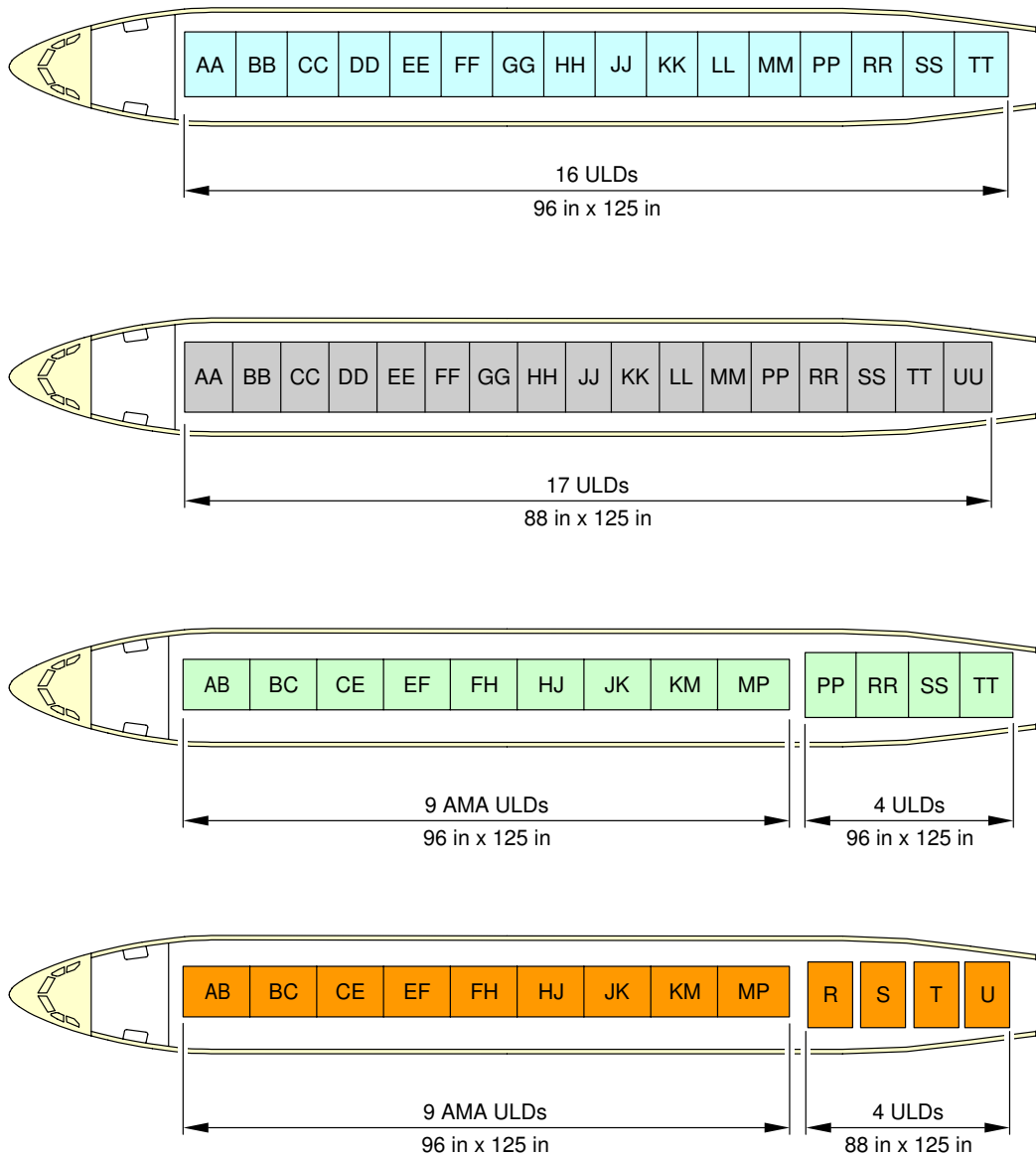

F_AC_020602_1_0020101_01_01

Main Deck Cargo Compartment
Loading Combinations
FIGURE-2-6-2-991-002-A01

****ON A/C A330-200F**

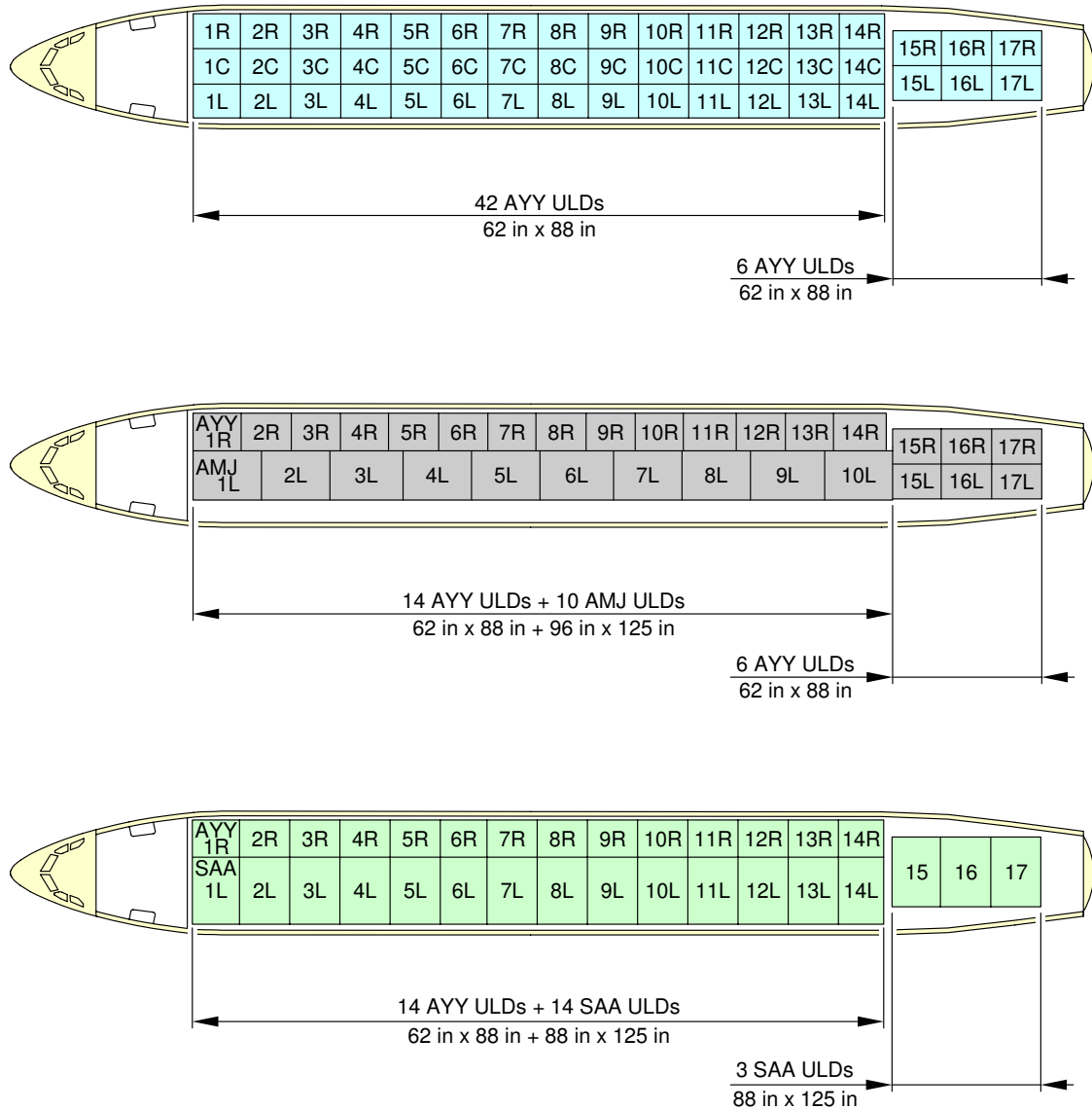

F_AC_020602_1_0030101_01_03

Main Deck Cargo Compartment
Loading Combinations
FIGURE-2-6-2-991-003-A01

****ON A/C A330-200F**

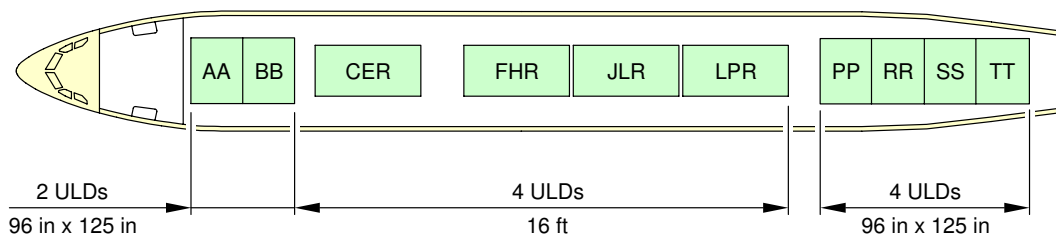
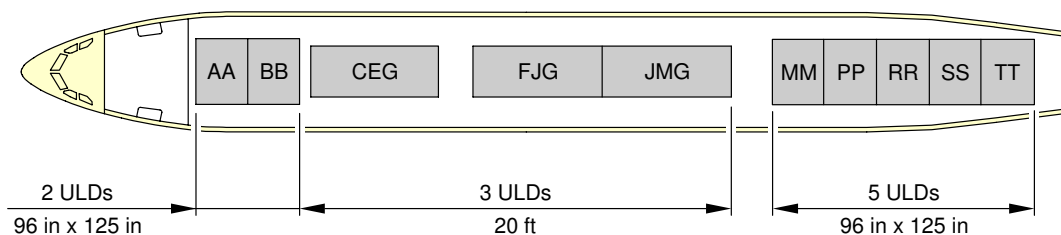
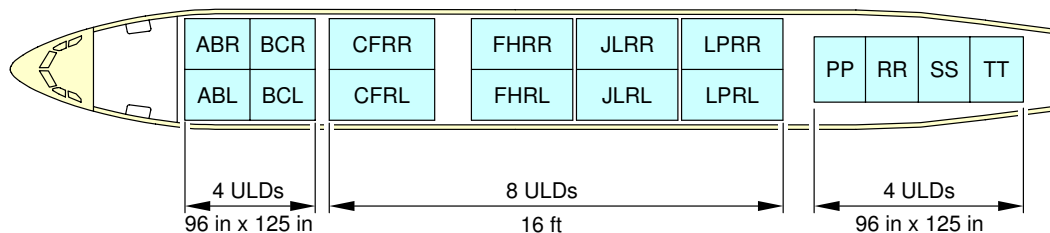

F_AC_020602_1_0050101_01_00

Main Deck Cargo Compartment
Loading Combinations
FIGURE-2-6-2-991-005-A01



2-6-3 Main and Lower Deck Cross-sections

****ON A/C A330-200F**

Main and Lower Deck Cross-sections

1. This section gives Main and Lower Deck Cross-sections for cargo version.

**ON A/C A330-200F

REFERENCE CARGO CONFIGURATION LAYOUT

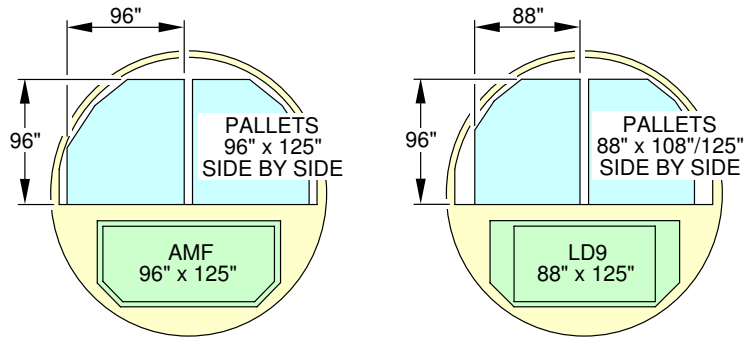

OPTIONAL CARGO CONFIGURATIONS

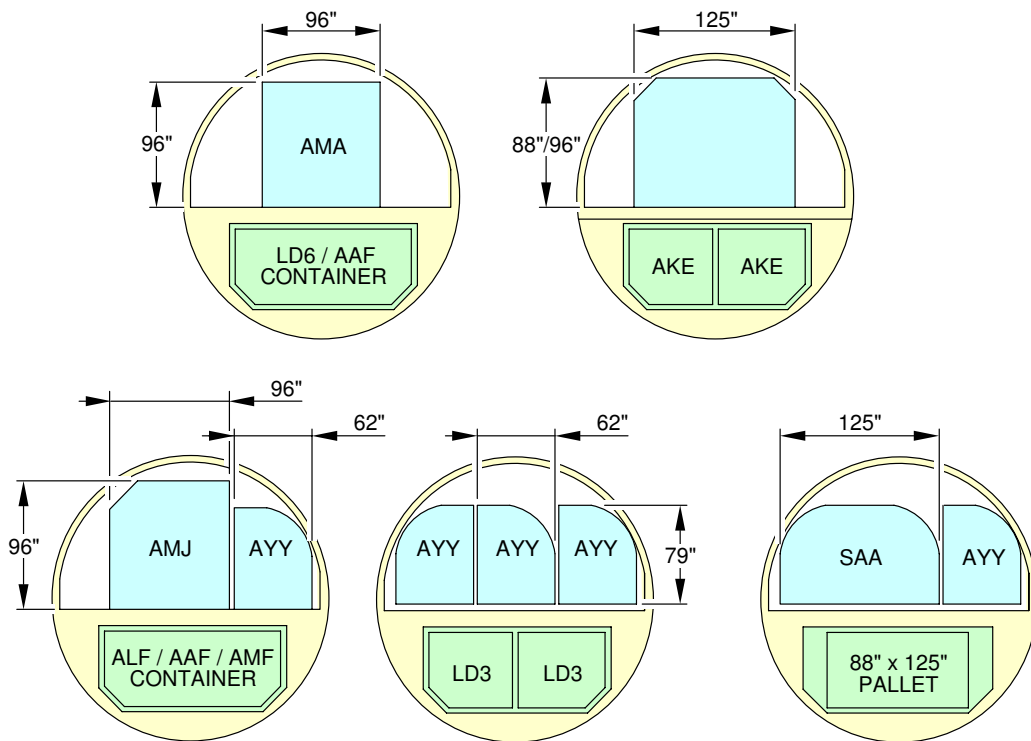

F_AC_020603_1_0010101_01_01

Main and Lower Deck Cross-sections
FIGURE-2-6-3-991-001-A01



2-7-0 Door Clearances

****ON A/C A330-200 A330-200F A330-300 A330-800 A330-900**

Door Clearances

1. This section provides door location, identification and clearances.

**ON A/C A330-200 A330-800

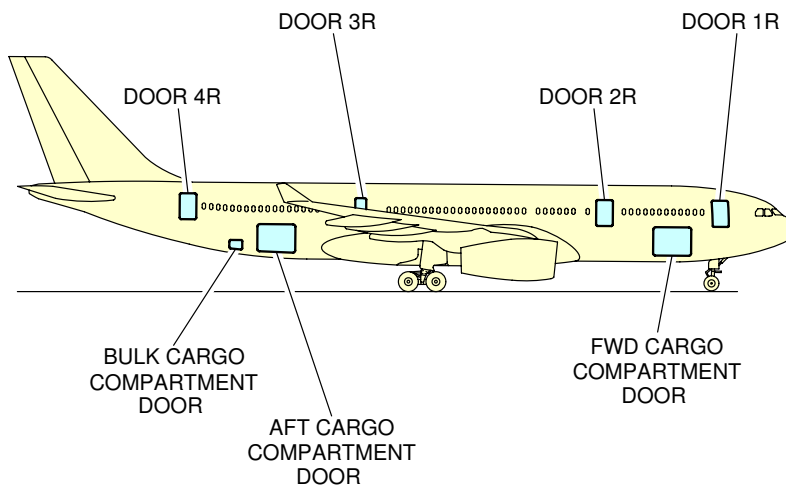
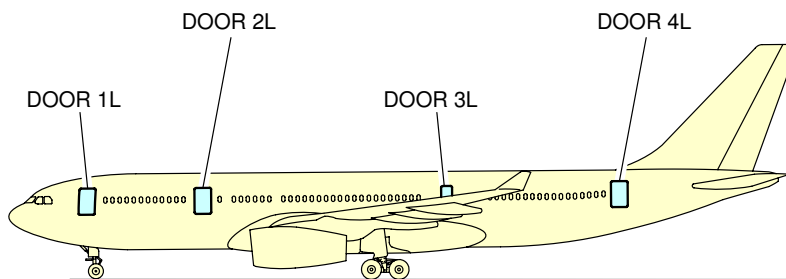

F_AC_020700_1_0060101_01_02

Door Clearances
Door Identification (Sheet 1 of 2)
FIGURE-2-7-0-991-006-A01

**ON A/C A330-200 A330-800

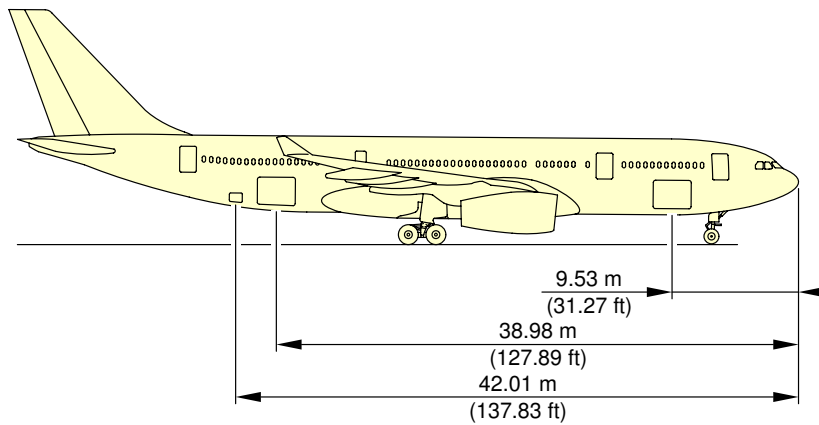
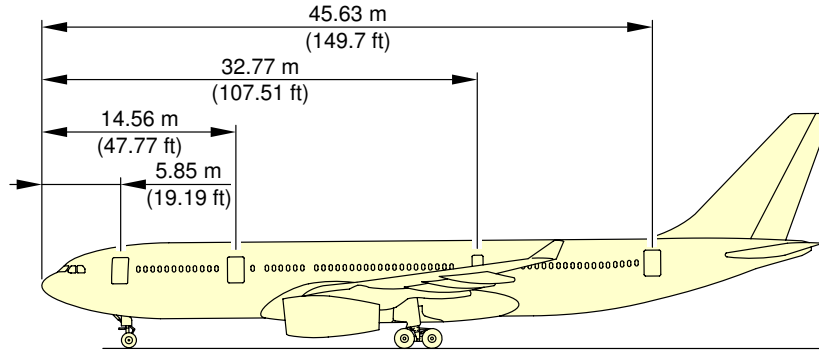

F_AC_020700_1_0060102_01_01

Door Clearances
Door Location (Sheet 2 of 2)
FIGURE-2-7-0-991-006-A01

**ON A/C A330-300 A330-900

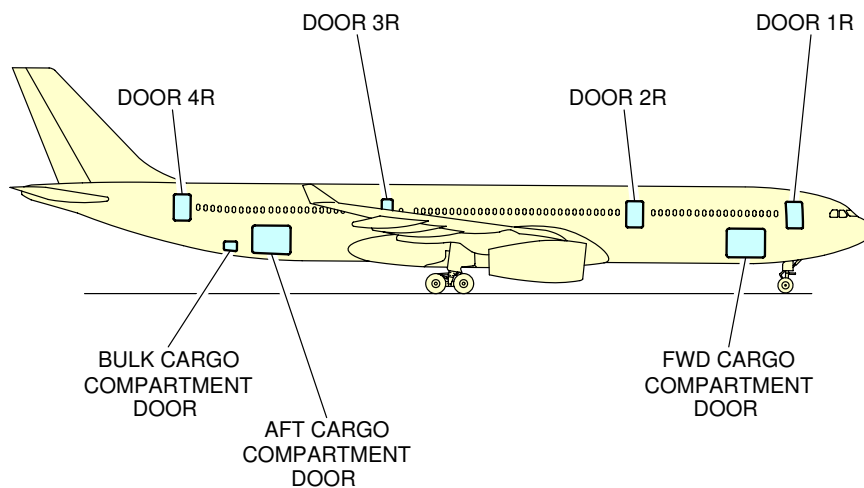
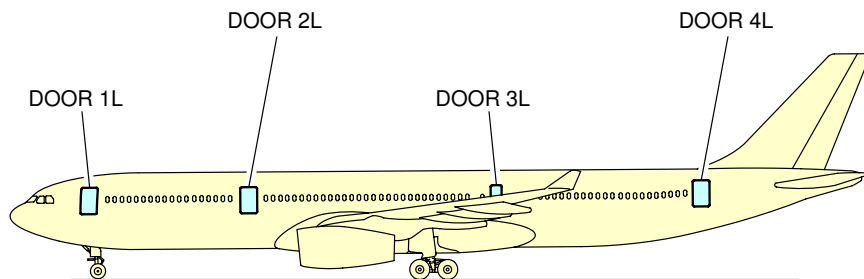

F_AC_020700_1_0060201_01_01

Door Clearances
Door Identification (Sheet 1 of 2)
FIGURE-2-7-0-991-006-B01

**ON A/C A330-300 A330-900

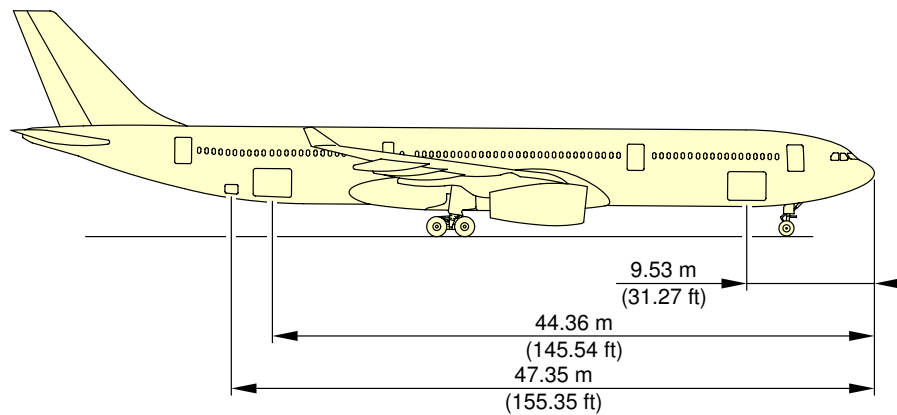
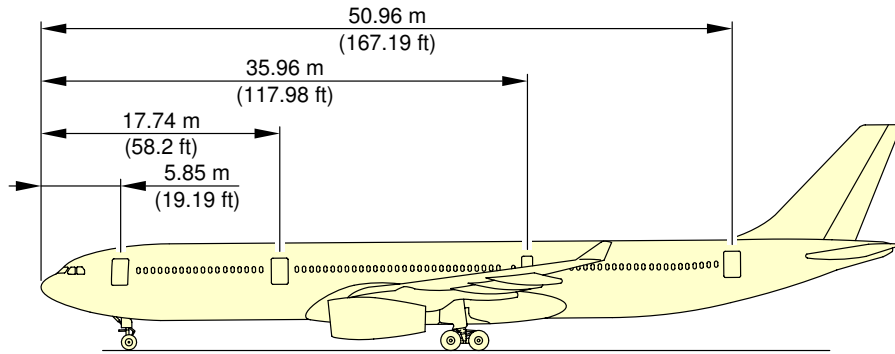

F_AC_020700_1_0060202_01_00

Door Clearances
Door Location (Sheet 2 of 2)
FIGURE-2-7-0-991-006-B01

**ON A/C A330-200F

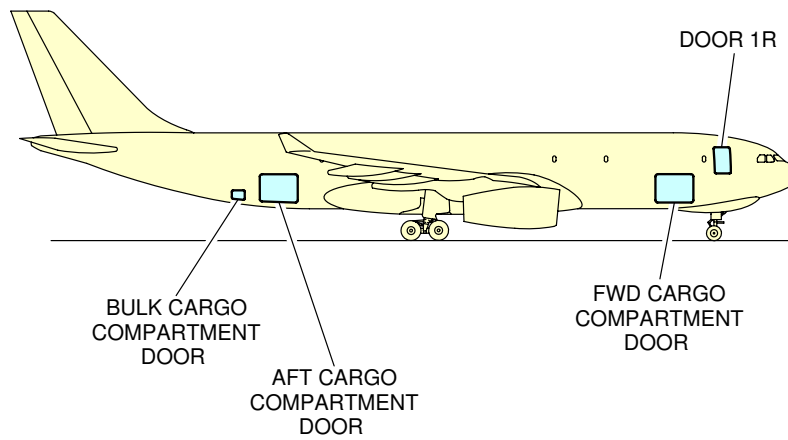
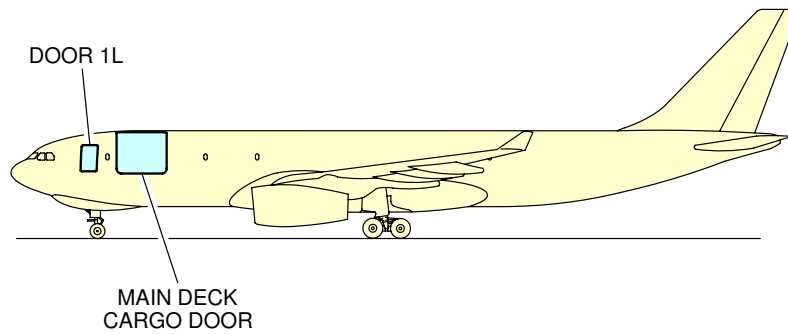

F_AC_020700_1_0060301_01_01

Door Clearances
Door Identification (Sheet 1 of 2)
FIGURE-2-7-0-991-006-C01

**ON A/C A330-200F

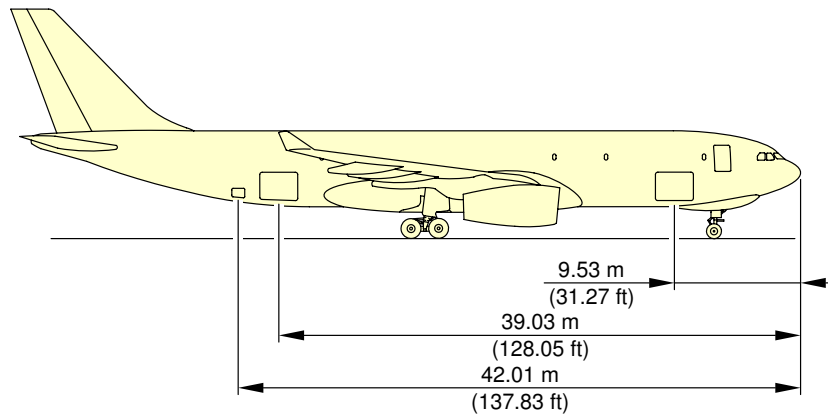
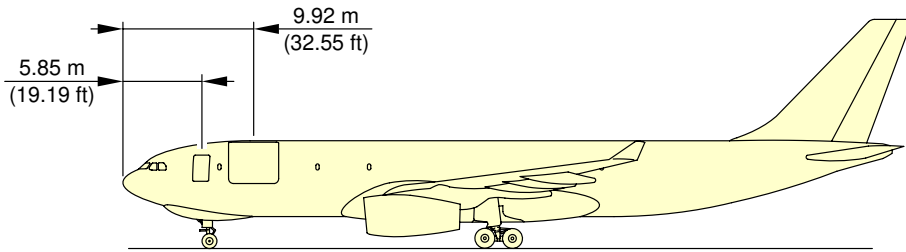

F_AC_020700_1_0060302_01_00

Door Clearances
Door Location (Sheet 2 of 2)
FIGURE-2-7-0-991-006-C01

****ON A/C A330-200 A330-300 A330-800 A330-900**

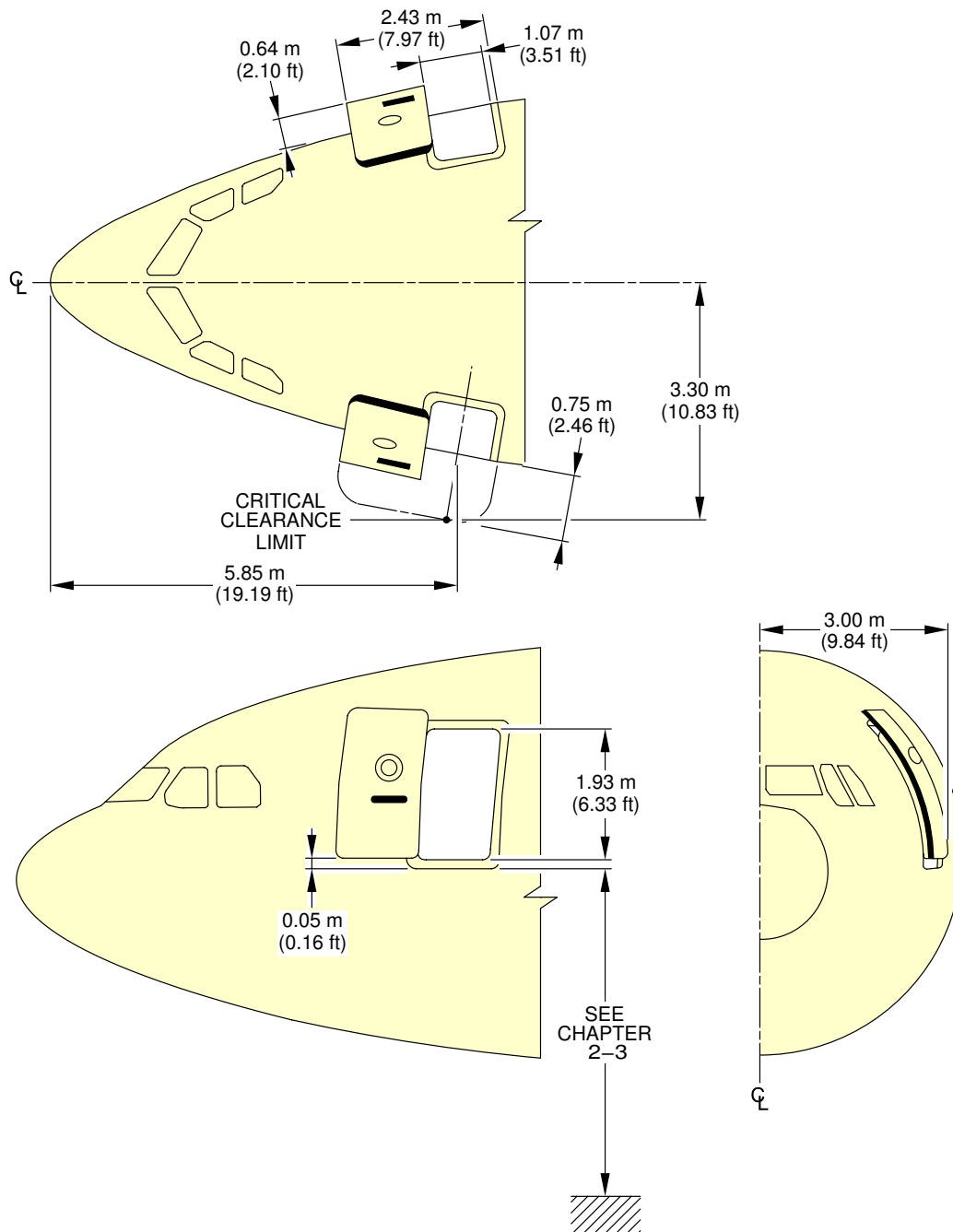

F_AC_020700_1_0120101_01_00

Door Clearances
Forward Passenger/Crew Doors
FIGURE-2-7-0-991-012-A01

****ON A/C A330-200F**

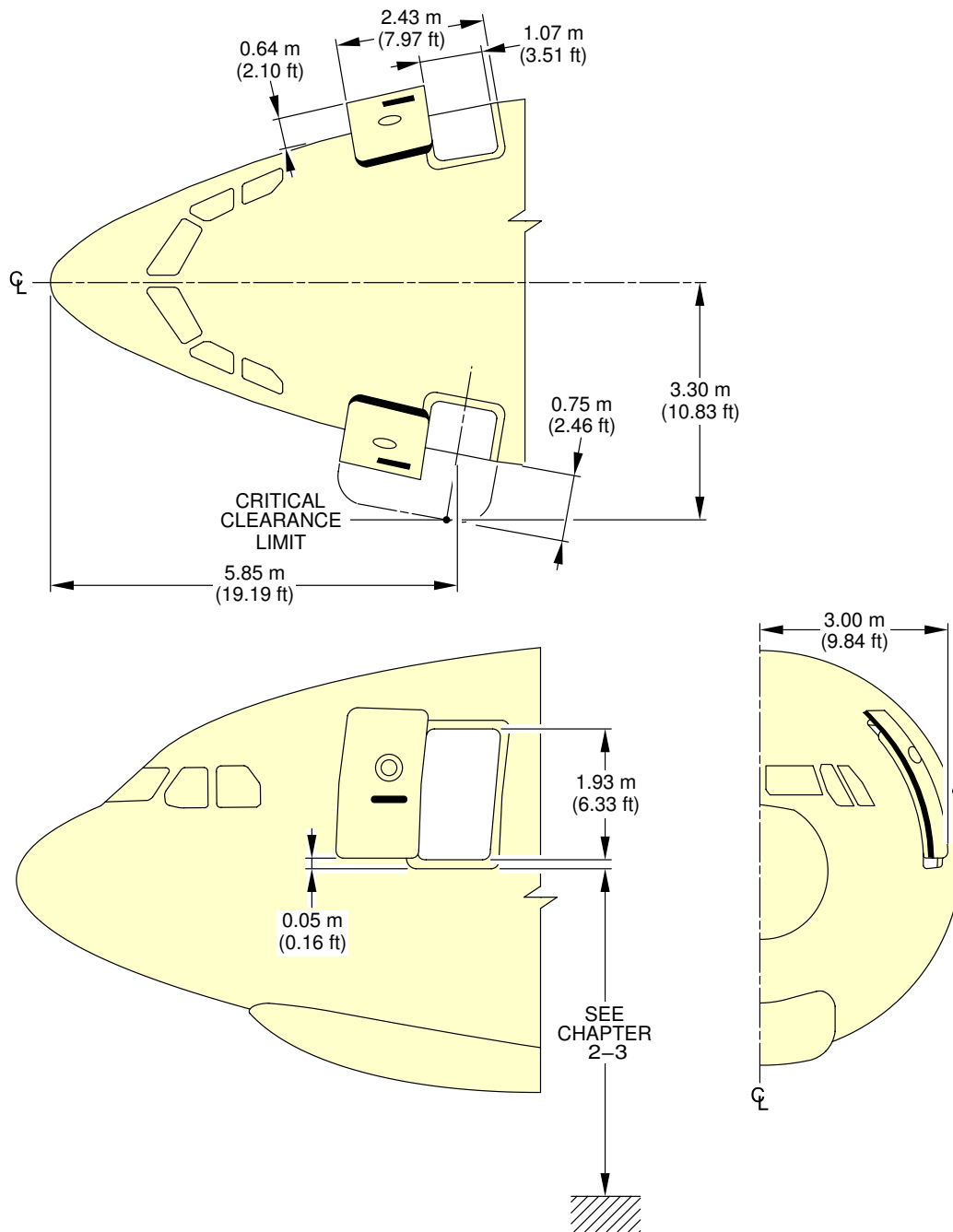

F_AC_020700_1_0130101_01_00

Door Clearances
 Forward Crew Doors
 FIGURE-2-7-0-991-013-A01

**ON A/C A330-200 A330-300 A330-800 A330-900

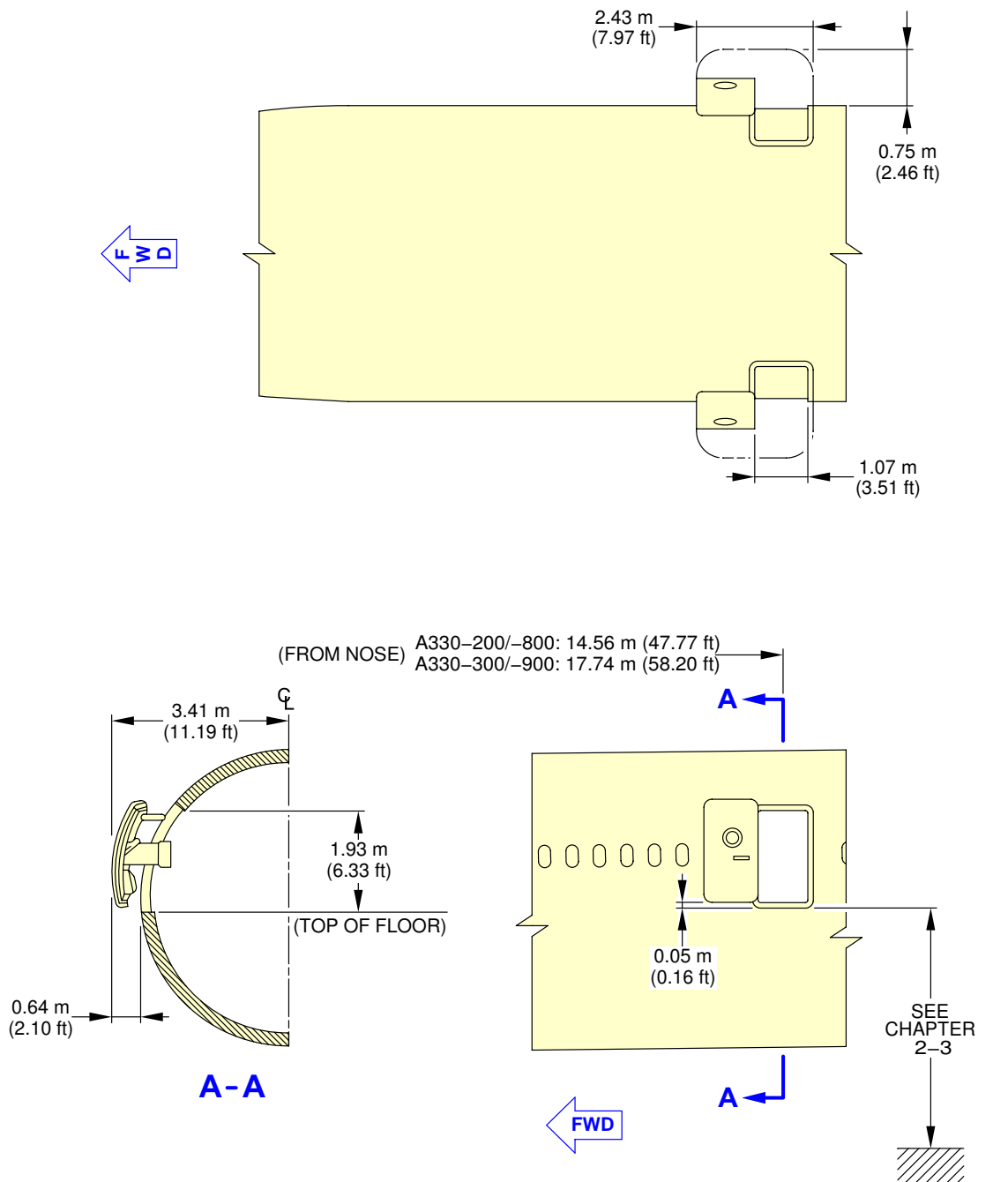

F_AC_020700_1_0140101_01_01

Door Clearances
Mid Passenger/Crew Doors
FIGURE-2-7-0-991-014-A01

**ON A/C A330-200 A330-300 A330-800 A330-900

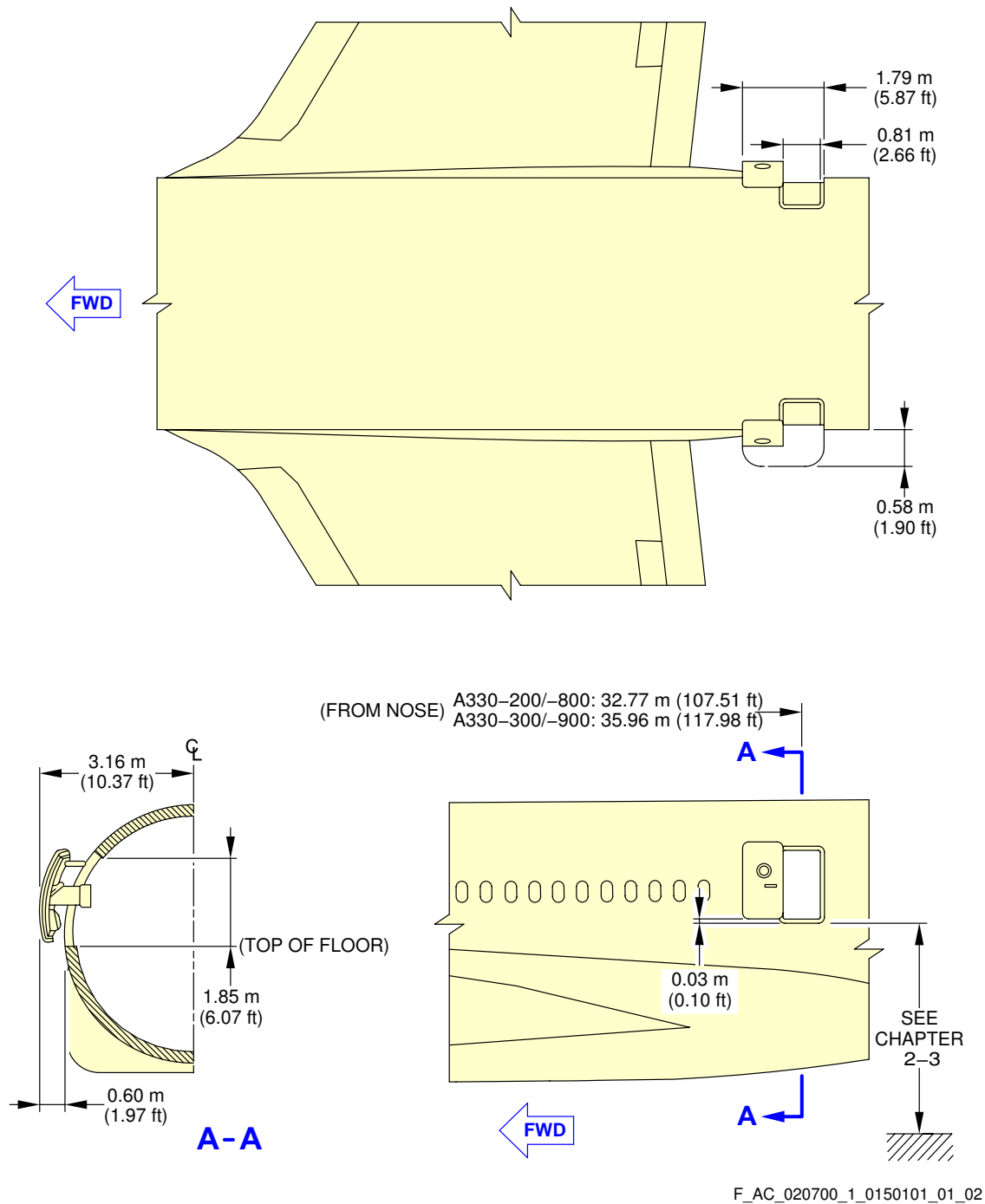

Door Clearances
Emergency Exits
FIGURE-2-7-0-991-015-A01

**ON A/C A330-200 A330-300 A330-800 A330-900

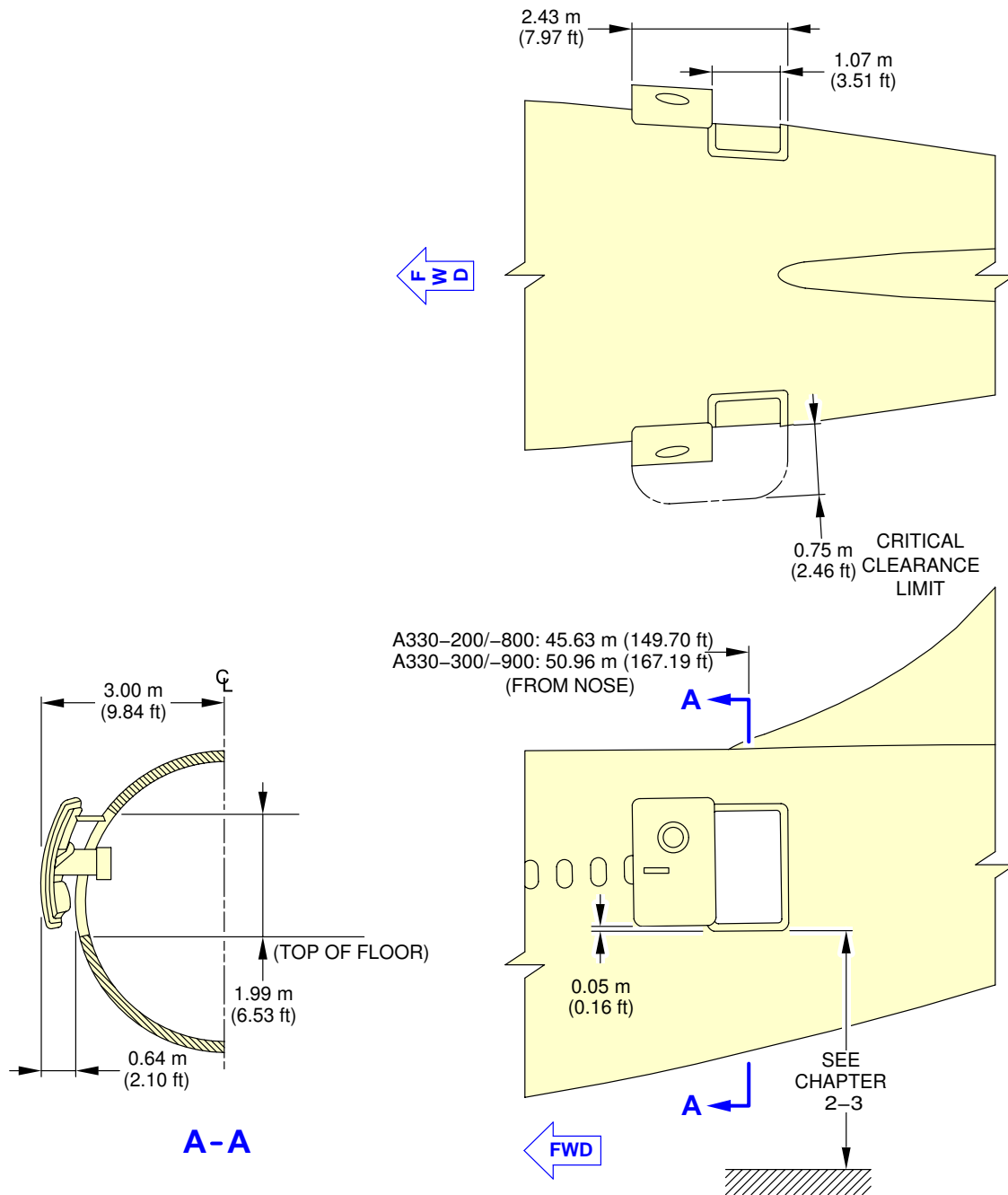

F_AC_020700_1_0160101_01_01

Door Clearances
Aft Passenger/Crew Doors
FIGURE-2-7-0-991-016-A01

**ON A/C A330-200 A330-300 A330-800 A330-900

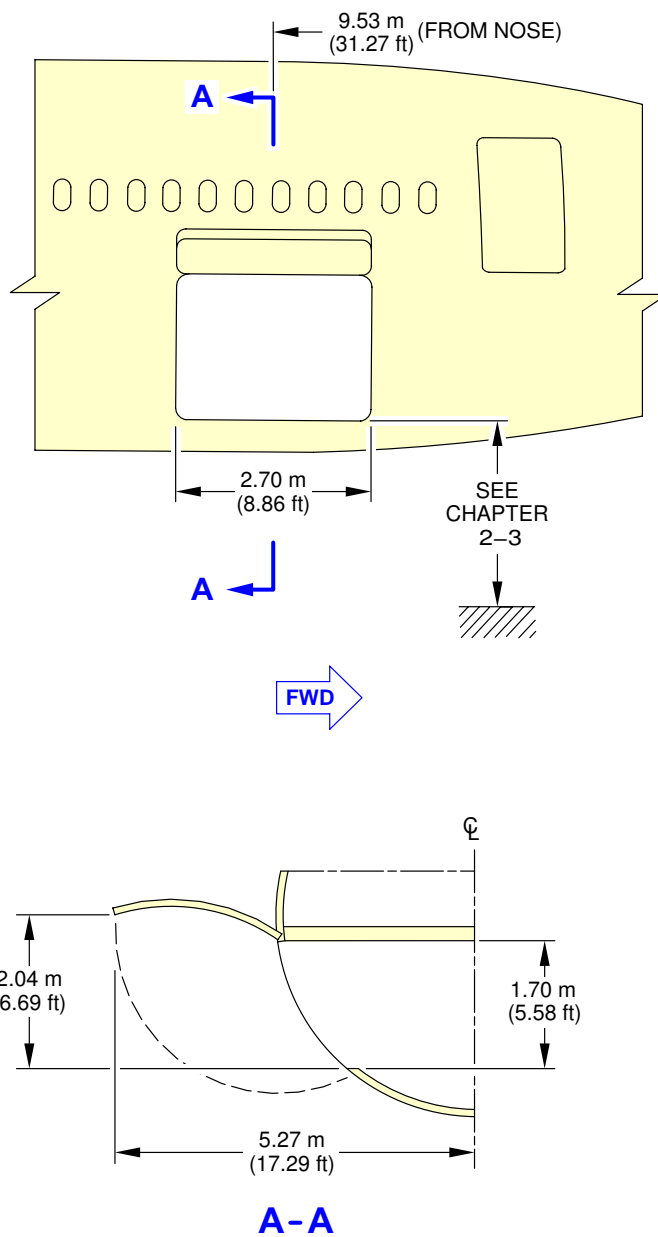

F_AC_020700_1_0170101_01_00

Door Clearances
Forward Cargo Compartment Door
FIGURE-2-7-0-991-017-A01

**ON A/C A330-200F

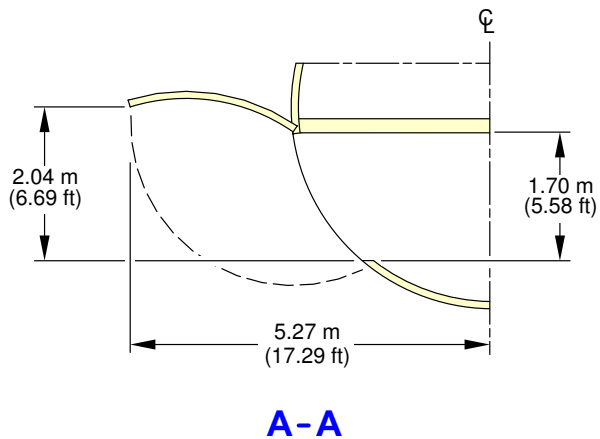
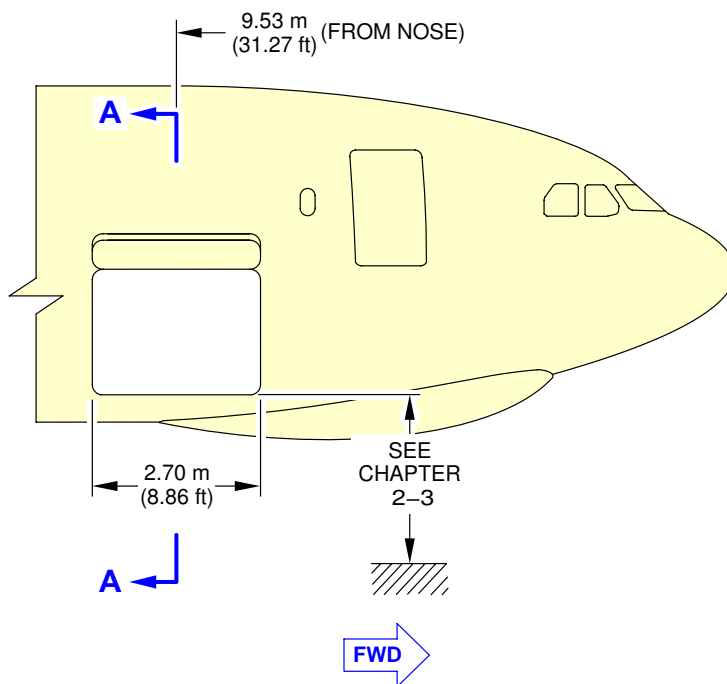

F_AC_020700_1_0180101_01_00

Door Clearances
Forward Cargo Compartment Door
FIGURE-2-7-0-991-018-A01

**ON A/C A330-200F

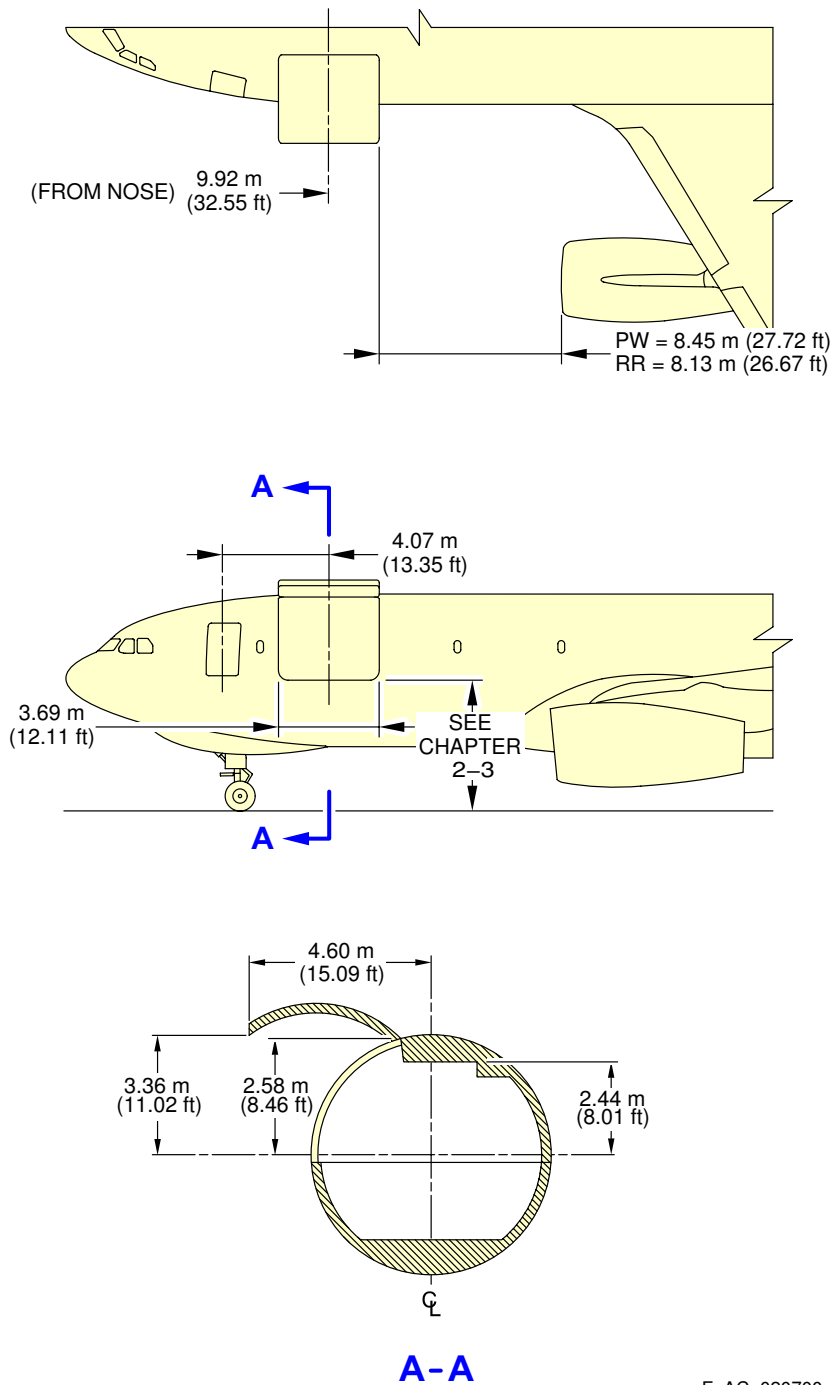

F_AC_020700_1_0190101_01_01

Door Clearances
Main Deck Cargo Compartment Door
FIGURE-2-7-0-991-019-A01

****ON A/C A330-200 A330-300 A330-800 A330-900**

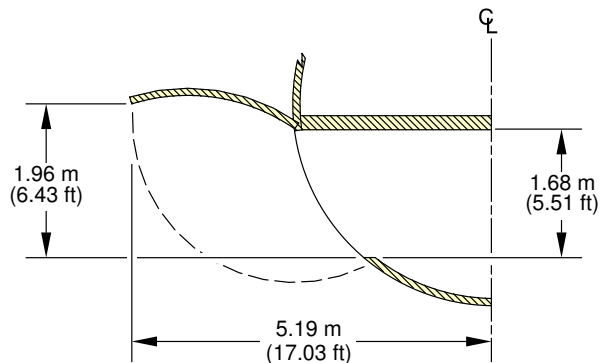
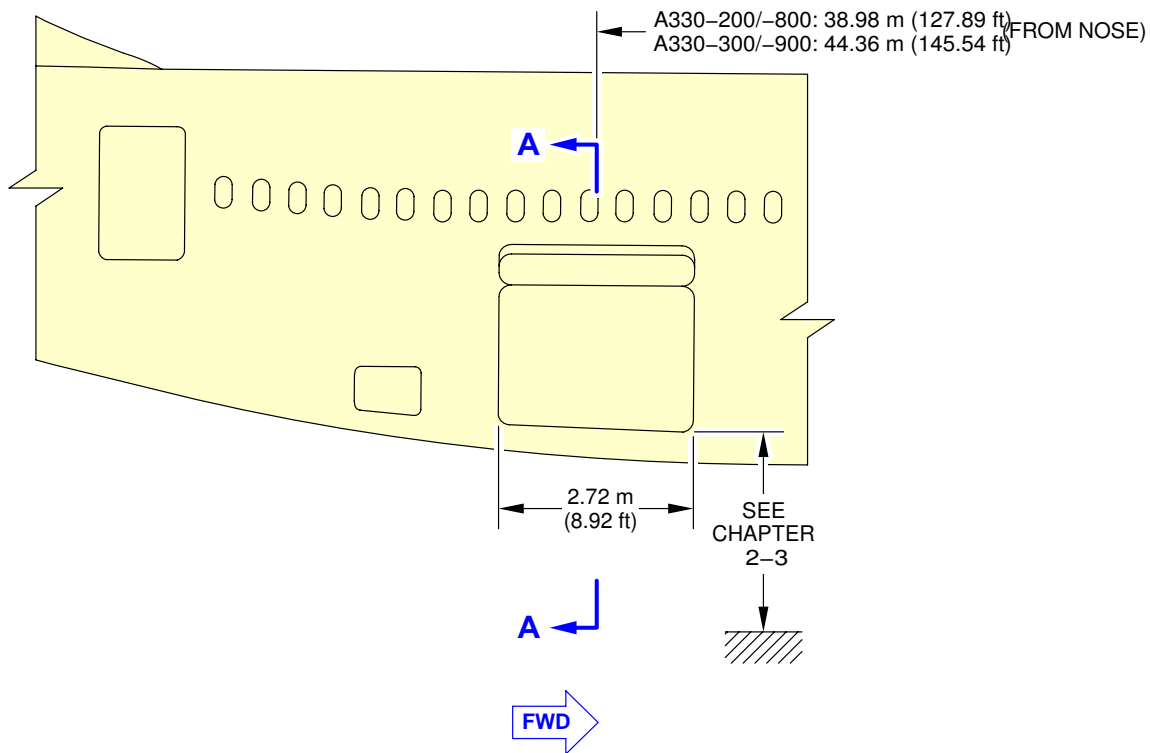

A-A

F_AC_020700_1_0200101_01_02

Door Clearances
Aft Cargo Compartment Door
FIGURE-2-7-0-991-020-A01

****ON A/C A330-200F**

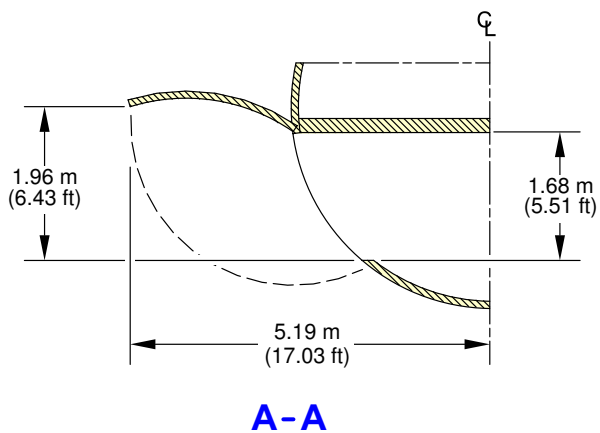
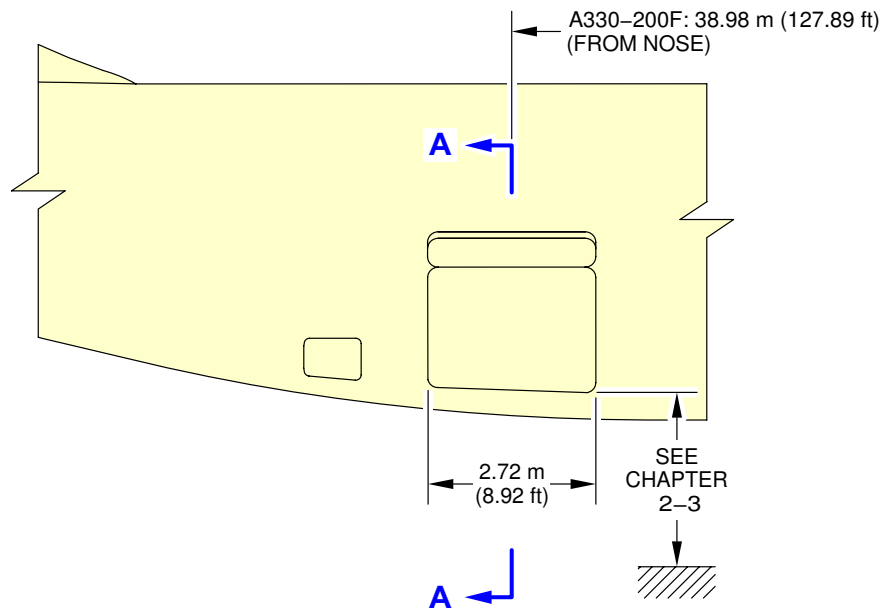

F_AC_020700_1_0210101_01_01

Door Clearances
Aft Cargo Compartment Door
FIGURE-2-7-0-991-021-A01

**ON A/C A330-200 A330-300 A330-800 A330-900

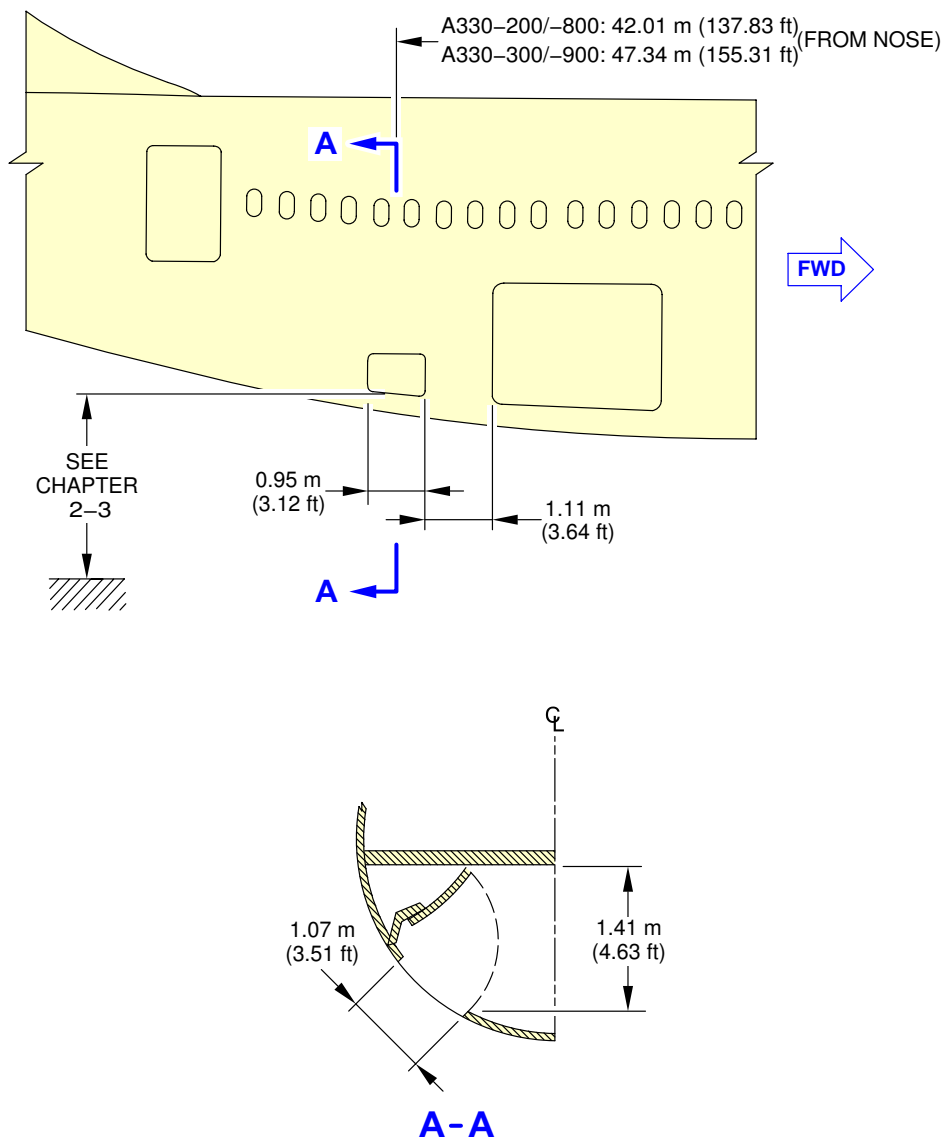

F_AC_020700_1_0220101_01_01

Door Clearances
Bulk Cargo Compartment Door
FIGURE-2-7-0-991-022-A01

****ON A/C A330-200F**

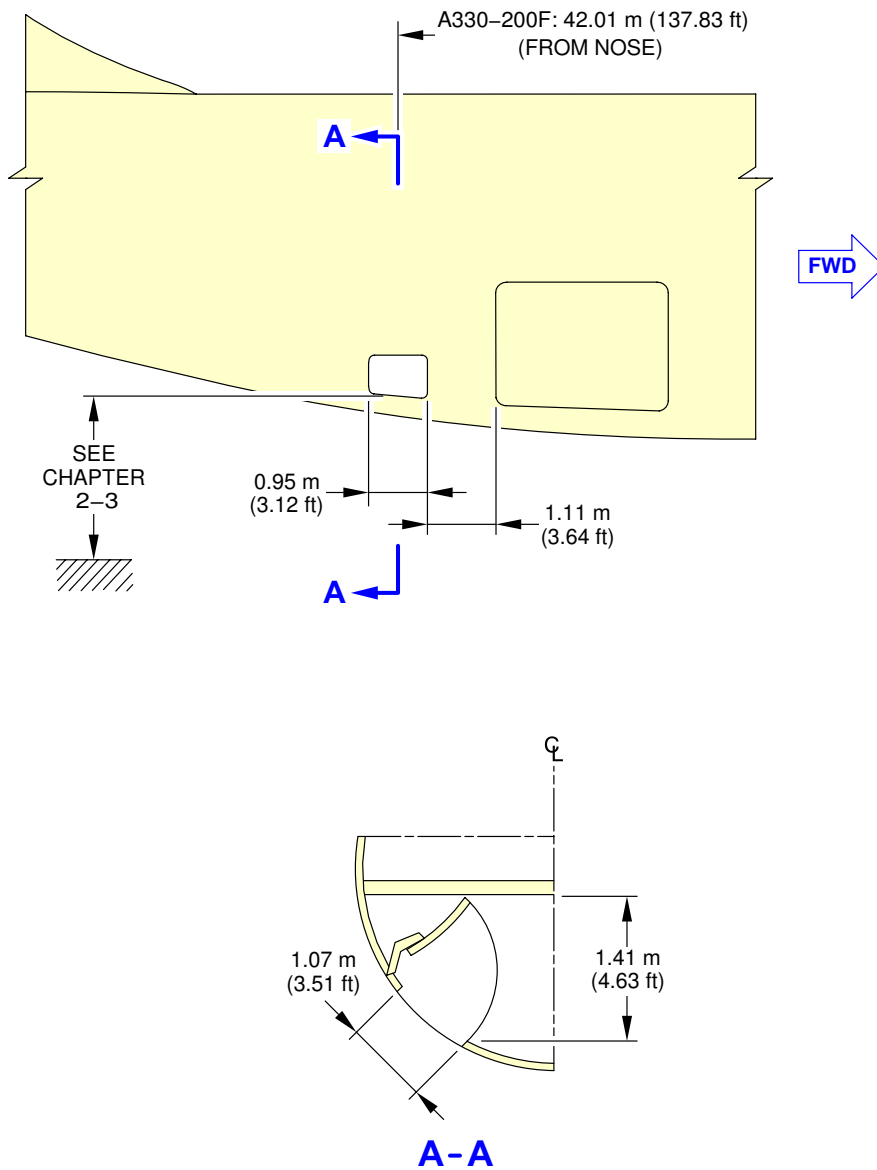

F_AC_020700_1_0230101_01_00

Door Clearances
Bulk Cargo Compartment Door
FIGURE-2-7-0-991-023-A01

**ON A/C A330-200 A330-200F A330-300 A330-800 A330-900

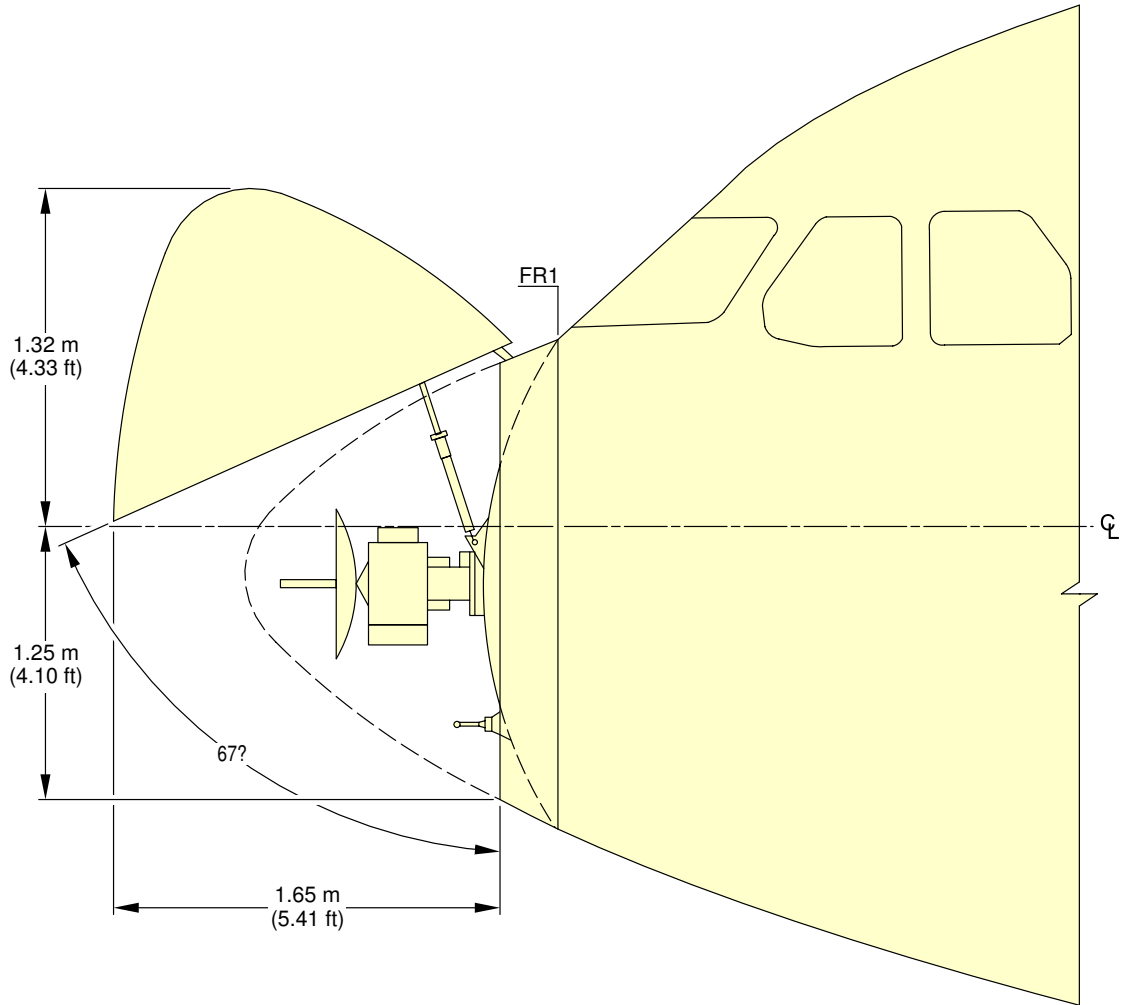

F_AC_020700_1_0240101_01_00

Door Clearances
Radome
FIGURE-2-7-0-991-024-A01

**ON A/C A330-200 A330-300 A330-800 A330-900

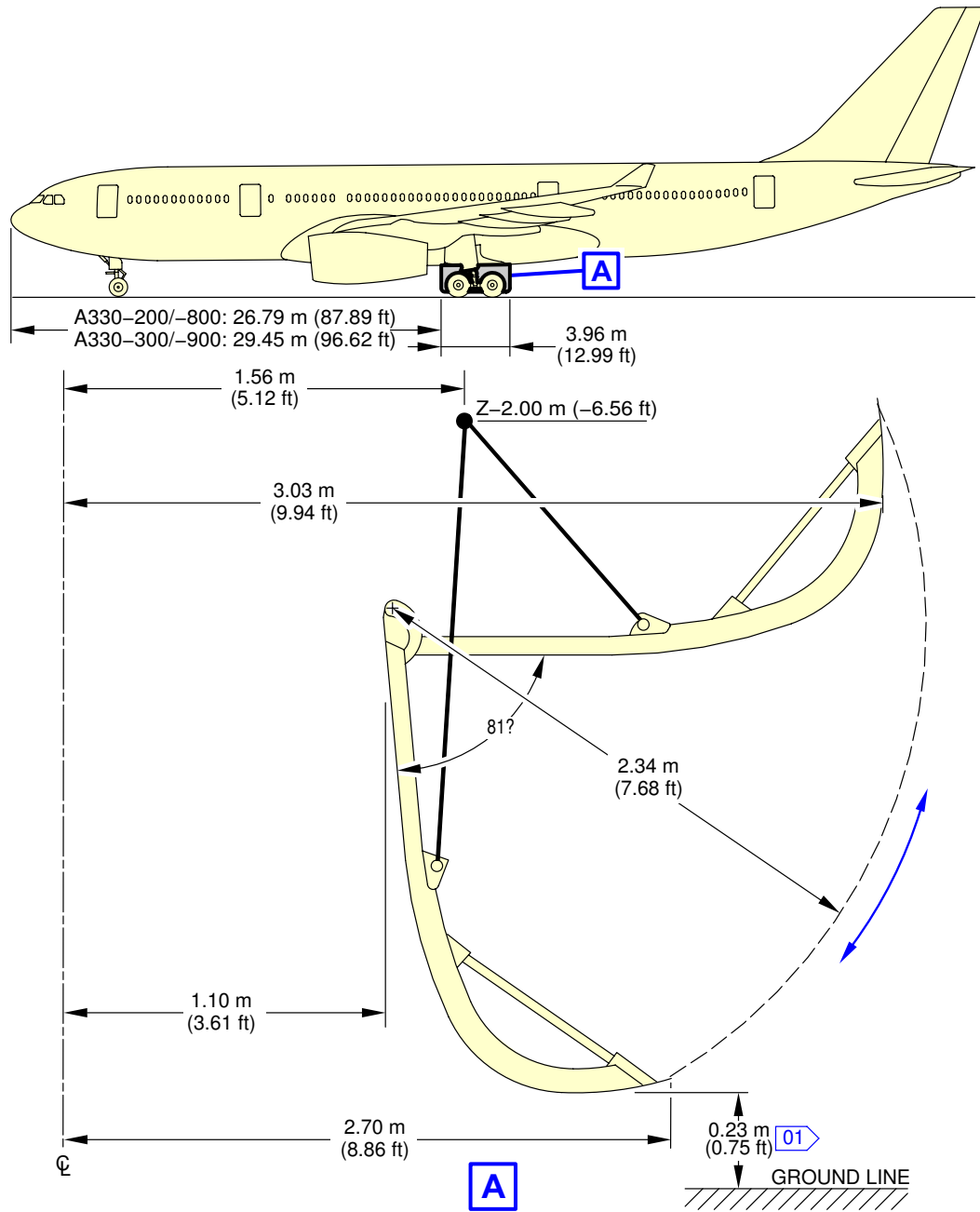

NOTE: LH SHOWN
RH SYMMETRICAL

01 DEPENDING ON CG POSITION AND AIRCRAFT WEIGHT.

F_AC_020700_1_0250101_01_01

Door Clearances
Main Landing Gear Doors
FIGURE-2-7-0-991-025-A01

****ON A/C A330-200F**

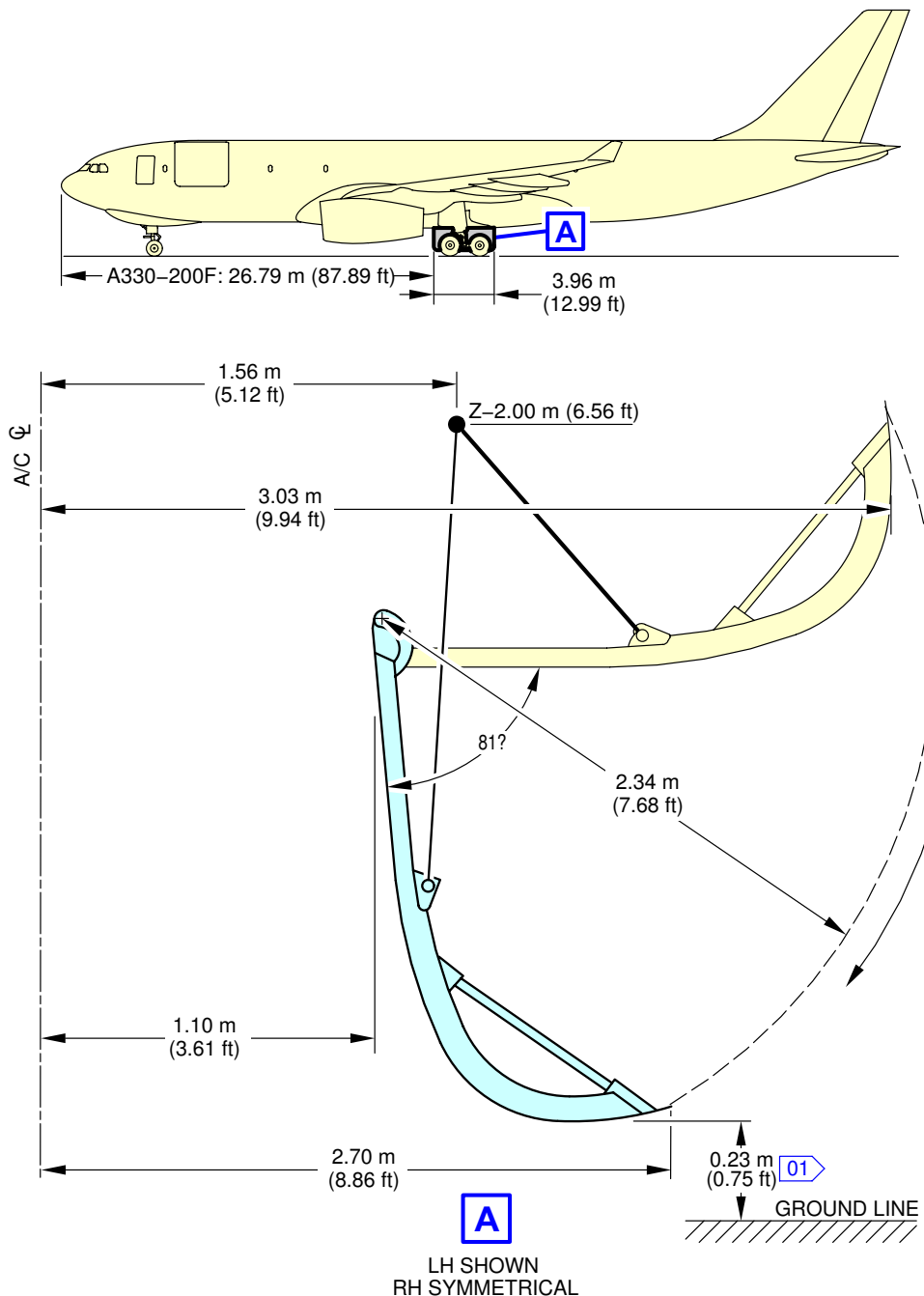

NOTE:

01 DEPENDING ON CG POSITION AND AIRCRAFT WEIGHT.

F_AC_020700_1_0260101_01_00

Door Clearances
Main Landing Gear Doors
FIGURE-2-7-0-991-026-A01

**ON A/C A330-200 A330-300 A330-800 A330-900

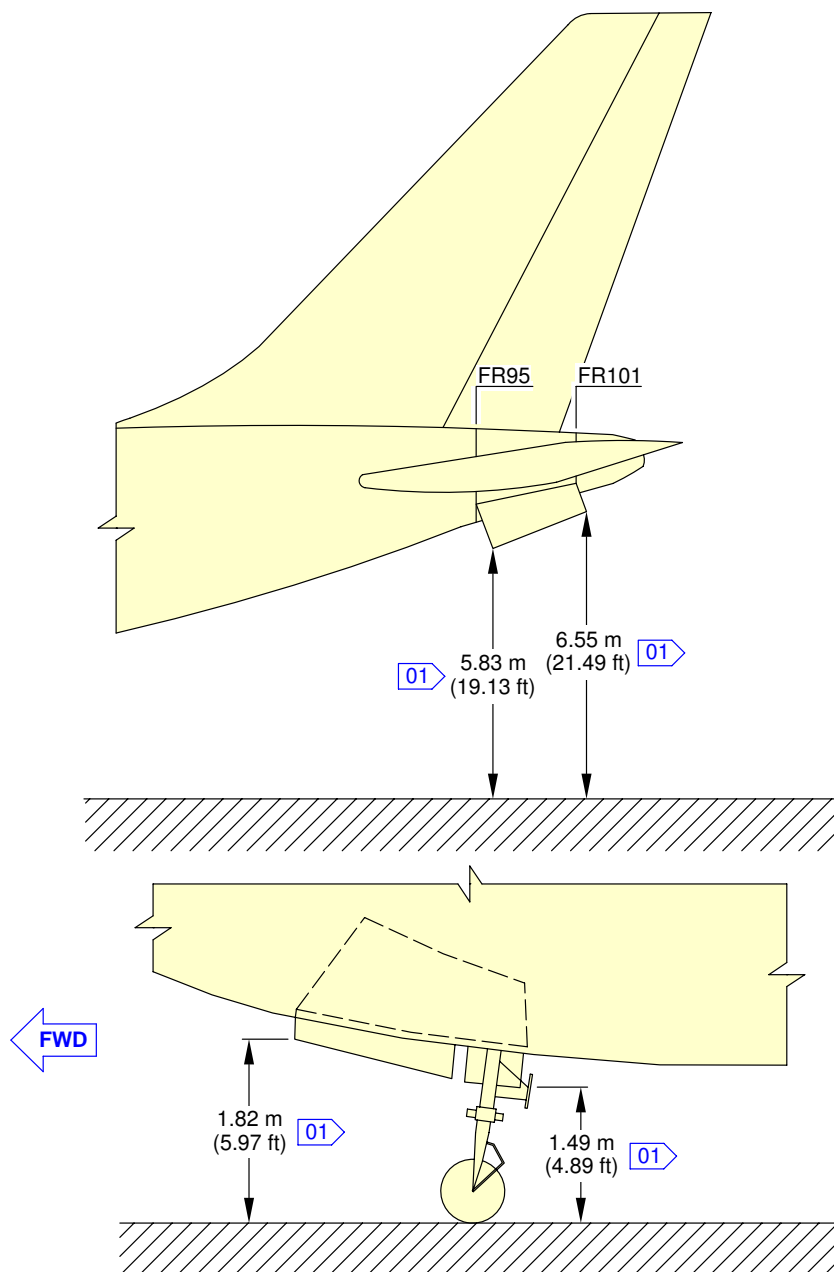

NOTE:
01 DEPENDING ON CG POSITION AND AIRCRAFT WEIGHT.

F_AC_020700_1_0270101_01_00

Door Clearances
APU and Nose Landing Gear Doors
FIGURE-2-7-0-991-027-A01

**ON A/C A330-200F

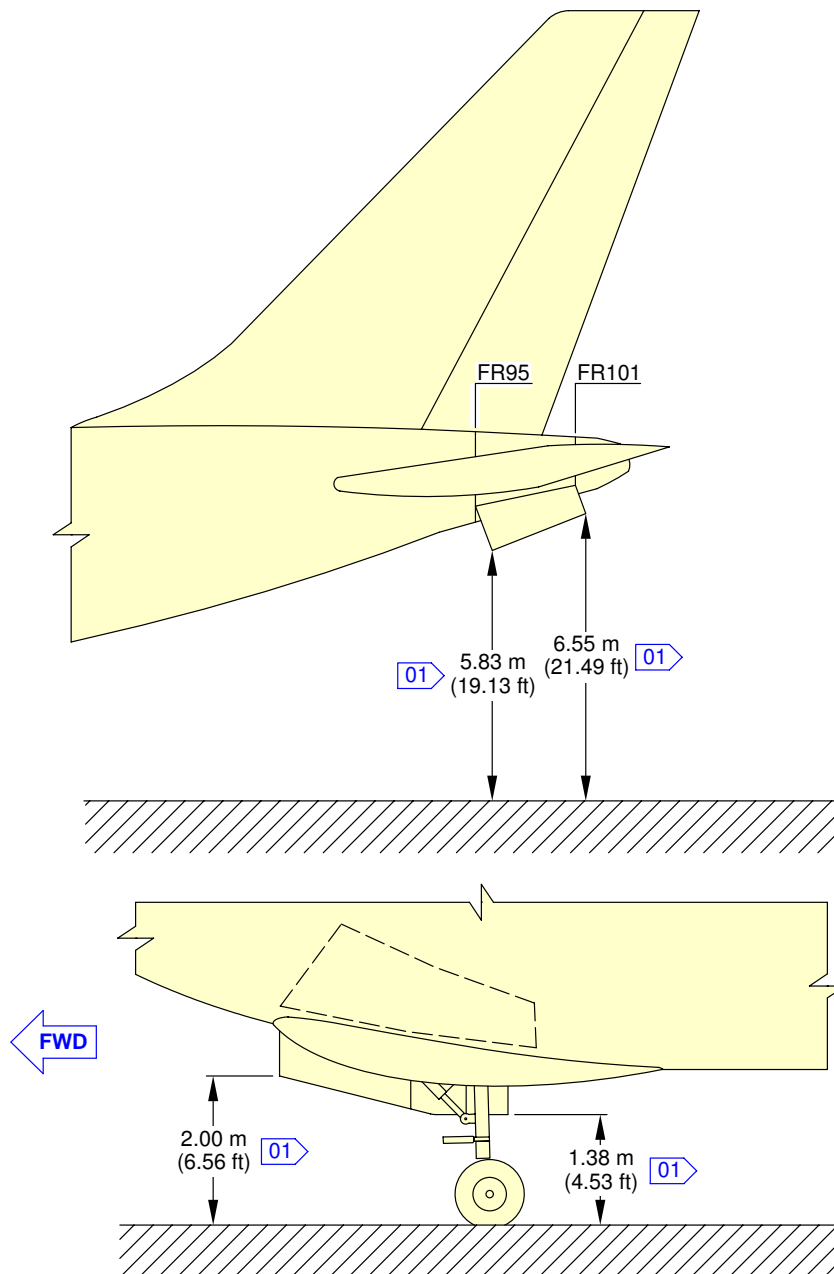

NOTE:
[01] DEPENDING ON CG POSITION AND AIRCRAFT WEIGHT.

F_AC_020700_1_0280101_01_00

Door Clearances
APU and Nose Landing Gear Doors
FIGURE-2-7-0-991-028-A01

2-8-0 **Escape Slides******ON A/C A330-200 A330-200F A330-300 A330-800 A330-900**Escape Slides

1. General

This section provides the location of the cabin escape facilities and their related clearances.

****ON A/C A330-200 A330-300 A330-800 A330-900**

2. Location

Slides/rafts facilities are provided at the following locations:

A. Door Slides/Rafts Facilities

- One dual-lane slide/raft at each door 1, 2 and 4 (total six)
- One single-lane slide at each door 3 (total two).

The slides are installed in a container in the lower part of the door.

****ON A/C A330-200F**

3. Location

Slides/rafts facilities are provided at the following locations:

A. Door Slides/Rafts Facilities

- One dual-lane slide/raft at each door 1 (total two).

The slides are installed in a container in the lower part of the door.

**ON A/C A330-200 A330-800

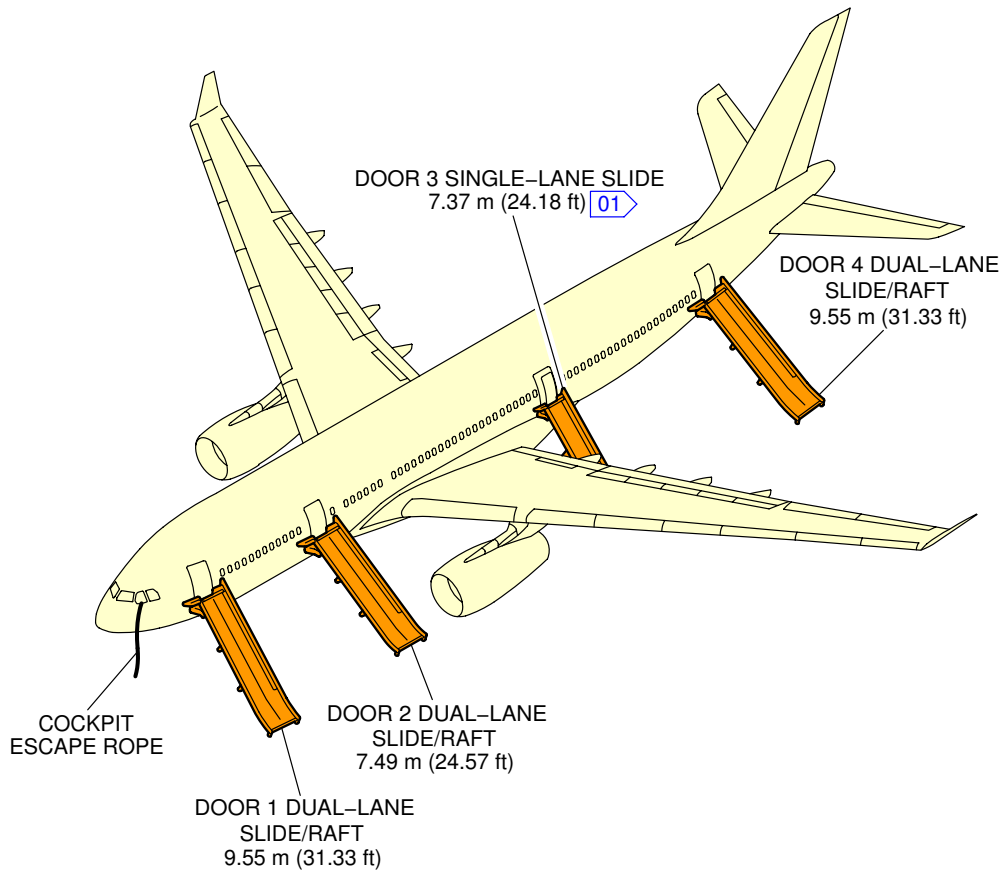

NOTE:
LH SHOWN, RH SYMMETRICAL.

01 THE SINGLE LANE SLIDE SHOWN IS FOR A TYPE "1" DOOR.
A DUAL LANE SLIDE/RAFT IS AVAILABLE FOR AIRCRAFT FITTED WITH A TYPE "A" DOOR.

F_AC_020800_1_0010101_01_02

Escape Slides
Location (Sheet 1 of 2)
FIGURE-2-8-0-991-001-A01

**ON A/C A330-200 A330-800

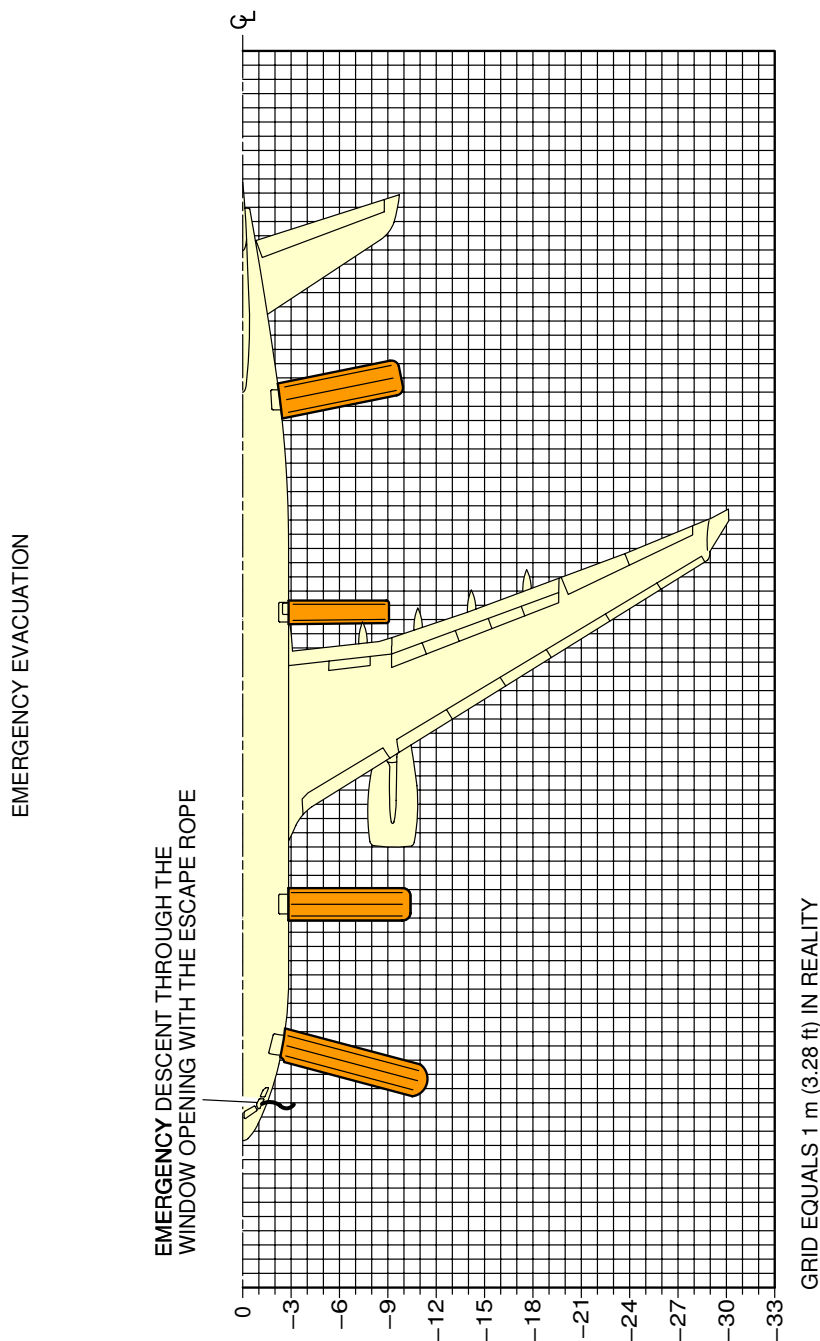

NOTE:
 - LH SHOWN, RH SYMMETRICAL.
 - DIMENSIONS ARE APPROXIMATE.

F_AC_020800_1_0010108_01_01

Escape Slides
 Dimensions (Sheet 2 of 2)
 FIGURE-2-8-0-991-001-A01

****ON A/C A330-200F**

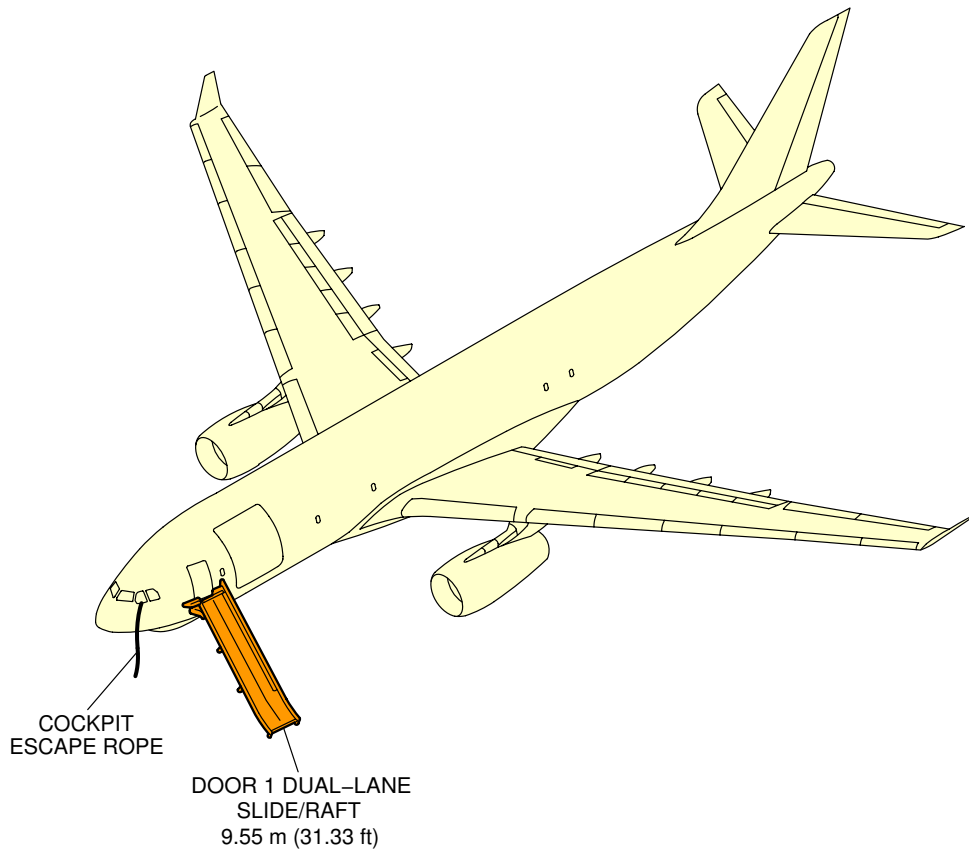

NOTE:
LH SHOWN, RH SYMMETRICAL.

F_AC_020800_1_0010201_01_02

Escape Slide
Location (Sheet 1 of 2)
FIGURE-2-8-0-991-001-B01

**ON A/C A330-200F

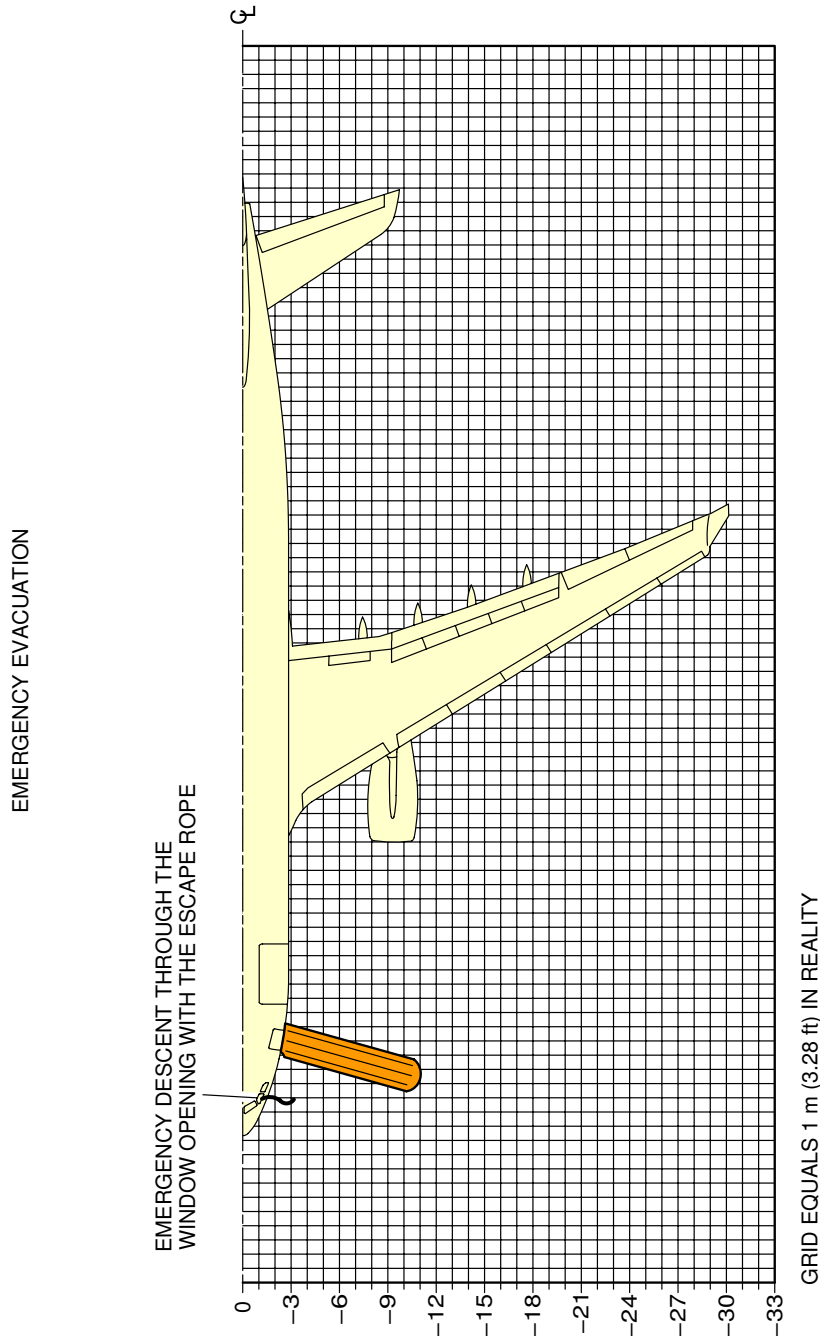

NOTE:
 - LH SHOWN, RH SYMMETRICAL.
 - DIMENSIONS ARE APPROXIMATE.

F_AC_020800_1_0010202_01_01

Escape Slide
 Dimensions (Sheet 2 of 2)
 FIGURE-2-8-0-991-001-B01

**ON A/C A330-300 A330-900

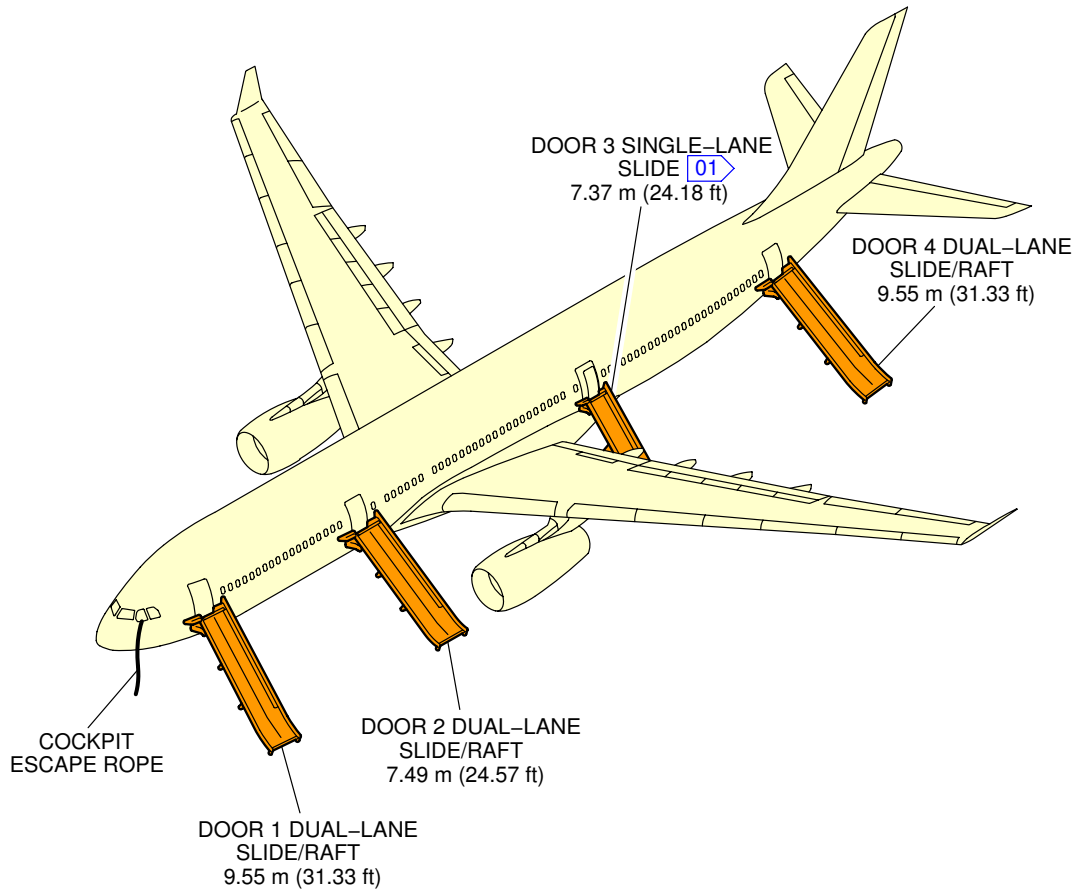

NOTE:

LH SHOWN, RH SYMMETRICAL.

(01) THE SINGLE LANE SLIDE SHOWN IS FOR A TYPE "1" DOOR.

A DUAL LANE SLIDE/RAFT IS AVAILABLE FOR AIRCRAFT FITTED WITH A TYPE "A" DOOR.

F_AC_020800_1_0010301_01_02

Escape Slides
Location (Sheet 1 of 2)
FIGURE-2-8-0-991-001-C01

**ON A/C A330-300 A330-900

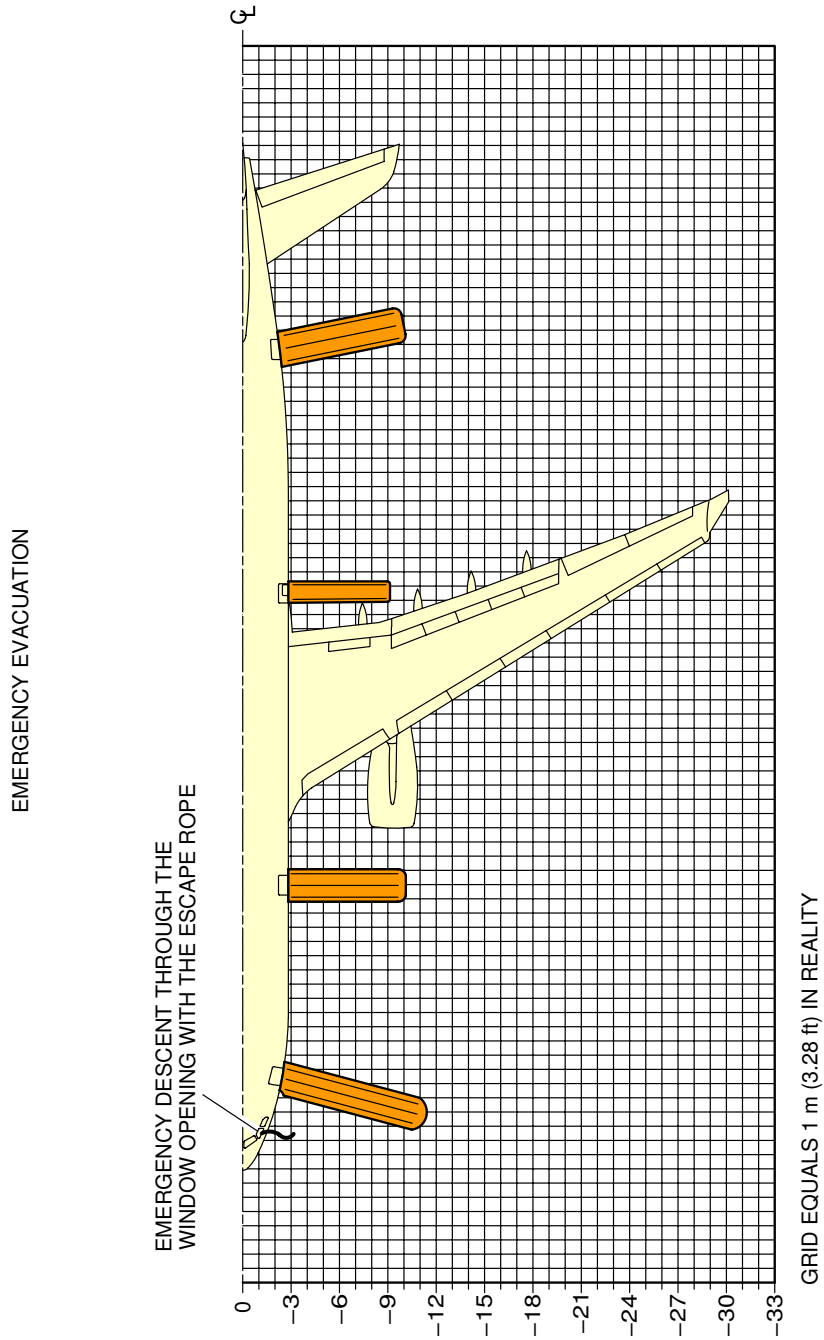

NOTE:
 - LH SHOWN, RH SYMMETRICAL.
 - DIMENSIONS ARE APPROXIMATE.

F_AC_020800_1_0010304_01_01

Escape Slides
 Dimensions (Sheet 2 of 2)
 FIGURE-2-8-0-991-001-C01

2-9-0 Landing Gear

****ON A/C A330-200 A330-200F A330-300 A330-800 A330-900**

Landing Gear Maintenance Pits

1. General

The minimum maintenance pit envelopes for the main landing gear shock absorber removal are shown in Figures 1 and 2.

All dimensions shown are minimum dimensions with zero clearances.

The dimensions for the pits have been determined for these design factors:

- The length and width of the pits allow the gear to rotate as the weight is taken off the landing gear
- The depth of the pits allow the shock absorber to be removed when all the weight is taken off the landing gear.

Dimensions for elevators and associated mechanisms must be added to those in Figures 1 and 2.

A. Elevators

These can be either mechanical or hydraulic. Elevators are used to:

- permit easy movement of persons and equipment around the main landing gears
- lift and remove the landing gear assemblies out of the pits.

B. Jacking

The aircraft must be in position over the pits to put the gear on the elevators. Jacks must be installed and engaged with all the jacking points (Ref. Section 2-14 for Jacking).

Jacks must support the total aircraft weight i.e. when the landing gears do not touch the elevators on retraction/extension tests.

When tripod support jacks are used, the tripod-base circle radius must be limited because the locations required for positioning the jacks are close to the sides of the pits.

**ON A/C A330-300 A330-900

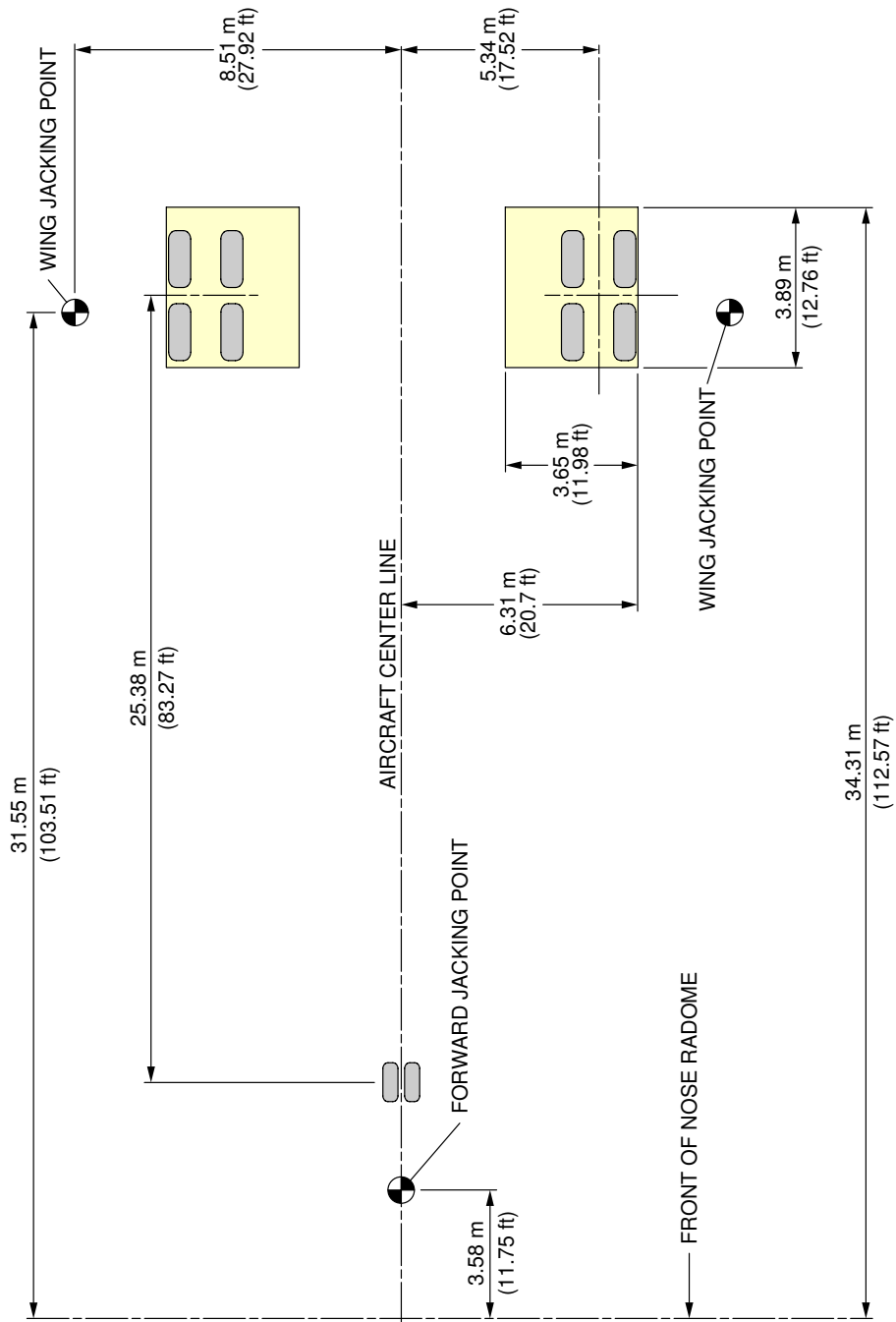

NOTE:
ENVELOPES SHOWN WITH ZERO CLEARANCE TO OUTSIDE EDGE OF TIRES.

F_AC_020900_1_0010101_01_00

Landing Gear Maintenance Pits
Maintenance Pit Envelopes (Sheet 1 of 2)
FIGURE-2-9-0-991-001-A01

****ON A/C A330-300 A330-900**

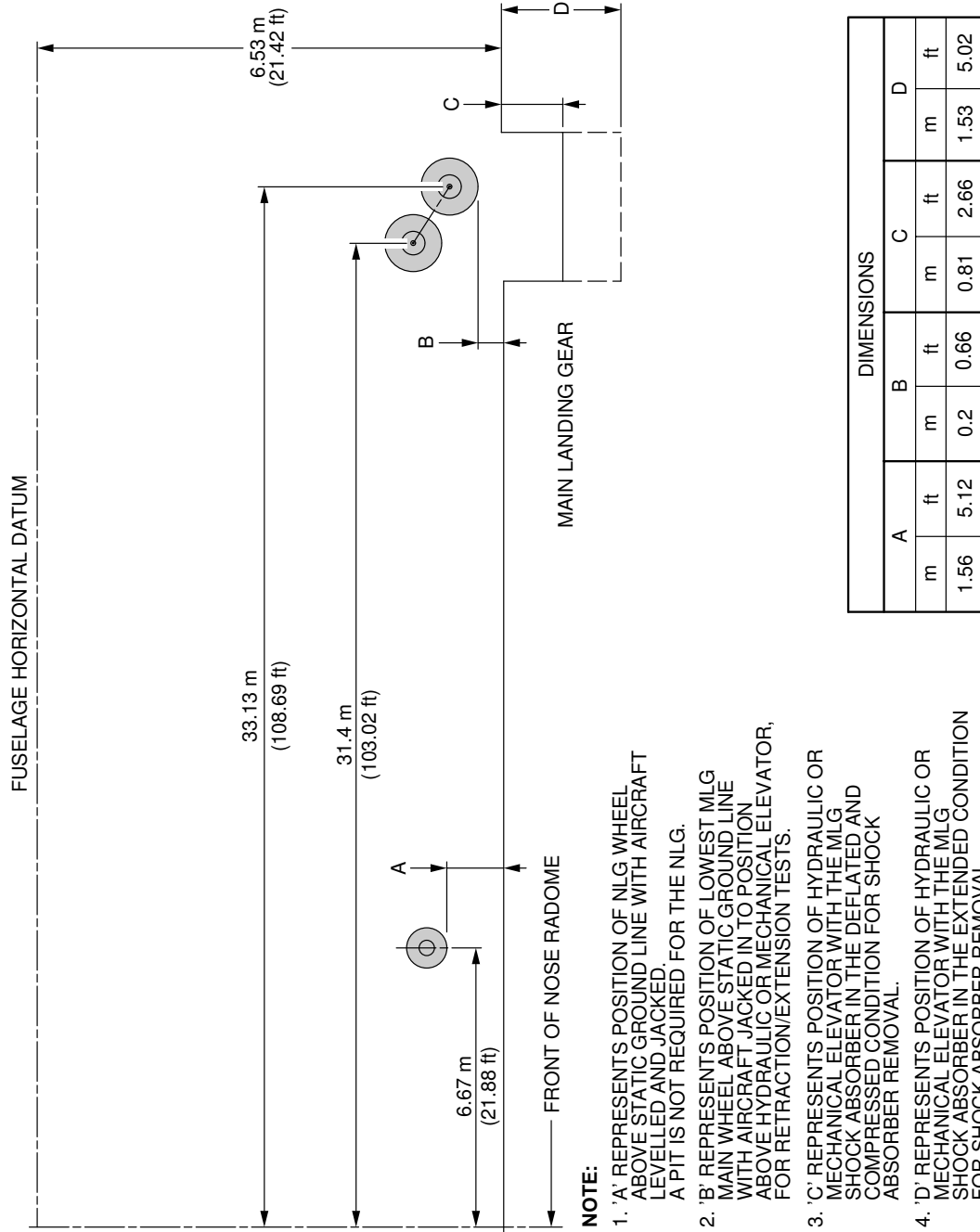

F_AC_020900_1_0010104_01_00

Landing Gear Maintenance Pits
 Maintenance Pit Envelopes (Sheet 2 of 2)
 FIGURE-2-9-0-991-001-A01

****ON A/C A330-200 A330-200F A330-800**

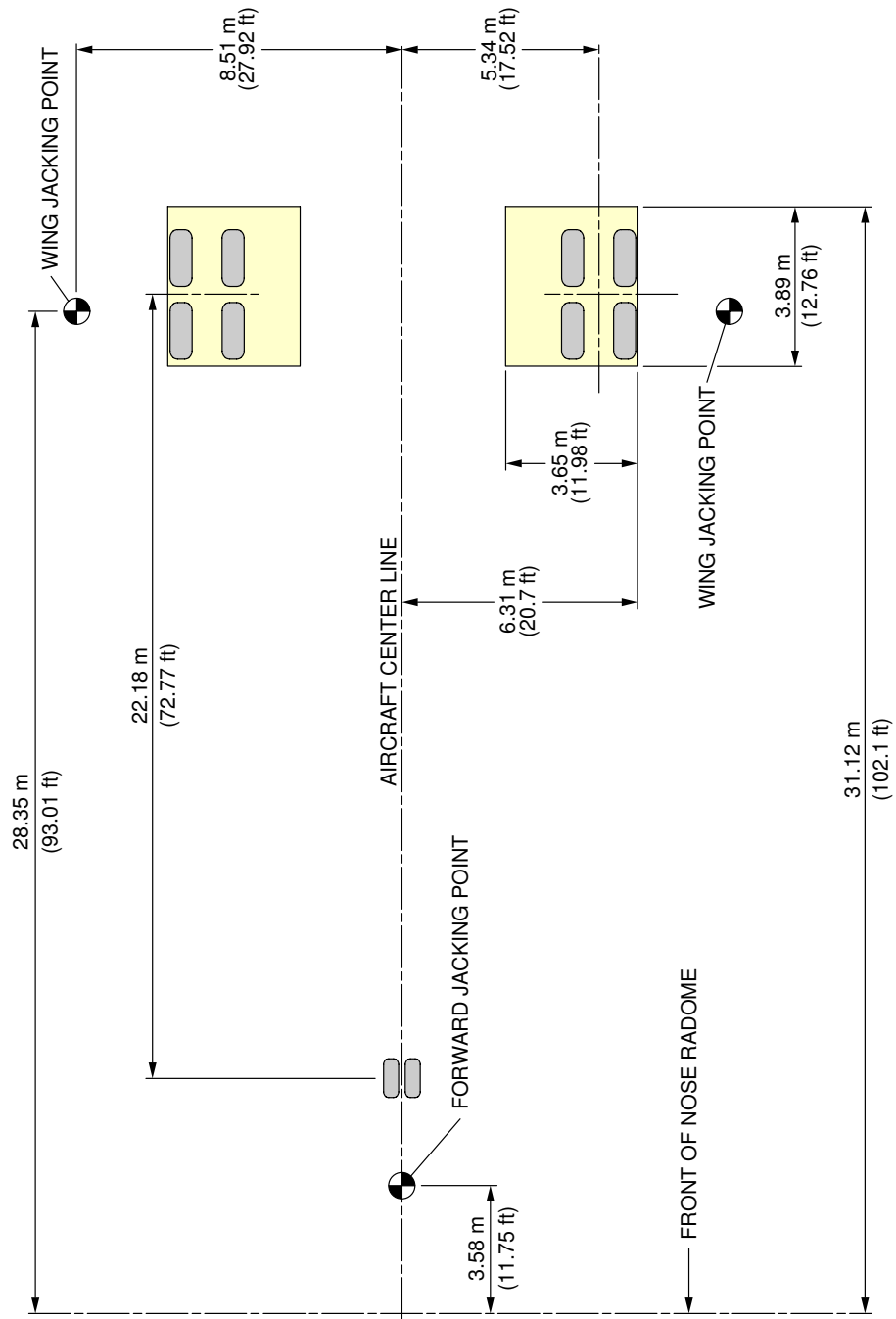

NOTE:
ENVELOPES SHOWN WITH ZERO CLEARANCE TO OUTSIDE EDGE OF TIRES.

F_AC_020900_1_0010301_01_00

Landing Gear Maintenance Pits
Maintenance Pit Envelopes (Sheet 1 of 2)
FIGURE-2-9-0-991-001-C01

**ON A/C A330-200 A330-200F A330-800

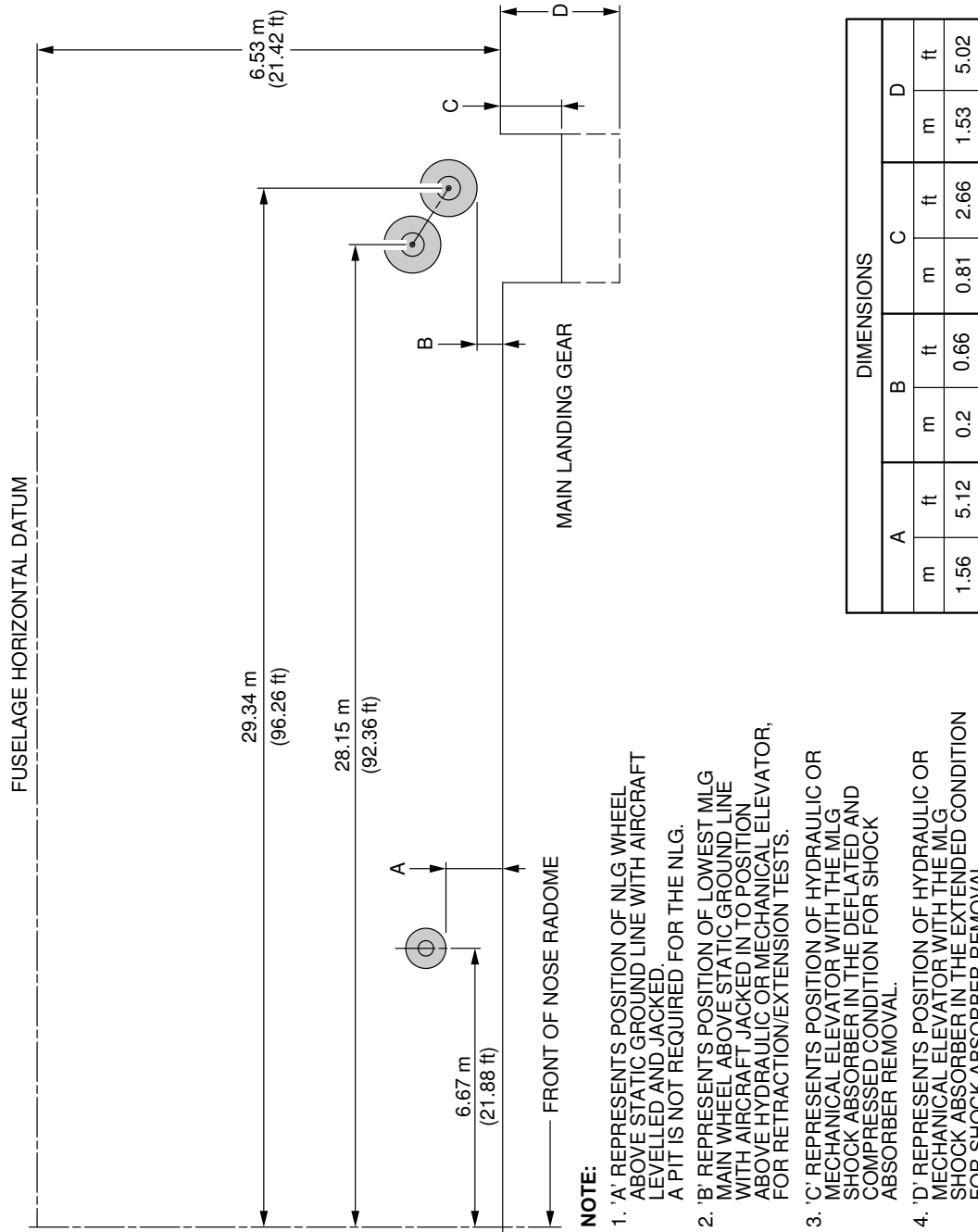

NOTE:

- 'A' REPRESENTS POSITION OF NLG WHEEL ABOVE STATIC GROUND LINE WITH AIRCRAFT LEVELLED AND JACKED. A PIT IS NOT REQUIRED FOR THE NLG.
- 'B' REPRESENTS POSITION OF LOWEST MLG MAIN WHEEL ABOVE STATIC GROUND LINE WITH AIRCRAFT JACKED IN TO POSITION ABOVE HYDRAULIC OR MECHANICAL ELEVATOR, FOR RETRACTION/EXTENSION TESTS.
- 'C' REPRESENTS POSITION OF HYDRAULIC OR MECHANICAL ELEVATOR WITH THE MLG SHOCK ABSORBER IN THE DEFLATED AND COMPRESSED CONDITION FOR SHOCK ABSORBER REMOVAL.
- 'D' REPRESENTS POSITION OF HYDRAULIC OR MECHANICAL ELEVATOR WITH THE MLG SHOCK ABSORBER IN THE EXTENDED CONDITION FOR SHOCK ABSORBER REMOVAL.

F_AC_020900_1_0010302_01_00

Landing Gear Maintenance Pits
Maintenance Pit Envelopes (Sheet 2 of 2)
FIGURE-2-9-0-991-001-C01

****ON A/C A330-200 A330-200F A330-300 A330-800 A330-900**

Landing Gear

1. General

The aircraft has:

- Two Main Landing Gears (MLG) with four wheel bogie assembly and related doors,
- A Nose Landing Gear (NLG) with twin wheel assembly and related doors.

The main landing gears are located under each wing and retract sideways towards the fuselage centerline.

The nose landing gear retracts forward into a fuselage compartment below the cockpit.

The retraction and extension of the landing gears and landing gear doors are operated hydraulically and mechanically. The control, sequence and indication are electrical.

In abnormal operation, the landing gears can be extended by gravity.

For the dimensions of the landing gear footprint and tire size, refer to 07-02-00.

2. Main Landing Gear and Doors

Each MLG has a leg assembly and a four-wheel bogie beam. The MLG leg includes a shortening mechanism, a bogie pitch trimmer and an oleo-pneumatic shock absorber. In-flight, with the MLG extended, the bogie is held in a trailing condition (rear wheels low) by an articulation linkage and a pitch trimmer. The folding sidestay is locked mechanically by a lockstay (which is operated by the downlock actuator) when the MLG is fully extended.

Each MLG bay has the following doors:

- A hydraulically-operated main door,
- A mechanically-operated hinged door,
- A fairing door on the MLG leg.

All the doors close when the MLG retracts. When the MLG is extended the main door closes and the hinged door stays open. A manually operated mechanism (for maintenance personnel) lets the main doors be opened for access to the MLG bay when the aircraft is on the ground.

3. Nose Landing Gear and Doors

The NLG includes a twin-wheel axle assembly and an oleo-pneumatic shock absorber. The NLG is supported longitudinally by a two-piece dragstay. The dragstay is locked mechanically by the lock links when the NLG is fully extended.

Each NLG bay has the following doors:

- Two hydraulically-operated FWD doors,
- Two mechanically-operated AFT doors,

- A fixed fairing door on the NLG leg.

All the doors close when the NLG retracts. When the NLG is extended the FWD doors close and the AFT doors stay open. A door opening mechanism lets the FWD doors be opened on the ground for access to the NLG bay.

4. Nose Wheel Steering (NWS)

Nose wheel steering system is a computer controlled electro-hydraulic system. The system uses the green main hydraulic power system to operate the hydraulic components.

The steering is controlled by two hand wheel transmitters in the cockpit, which supply the primary steering inputs to the BSCU (Brake and Steering Control Unit).

A steering disconnection box is installed on the NLG to disconnect the steering for towing.

For the operation and control of nose wheel steering, refer to AMM 32-51-00.

For the steering angle limits, refer to AMM 09-10-00.

5. Tow Truck Power

Electric power to the navigation lights can be provided through the tow truck power connector on the 5GC or 8GH service panel, see FIGURE 2-9-0-991-015-A and for connector definition, see 05-04-04.

6. Landing Gear Servicing Points

A. General

Fluid filling and gas charging of the MLG and NLG shock absorbers are accomplished through MS28889 standard valves.

B. Charging Pressures

For charging of the landing gear shock absorbers, refer to AMM 12-14-32.

7. Landing Gear Control

The landing gear and door operation is controlled electrically by one of the two Landing Gear Control and Interface Units (LGCIU). Control changes from one LGCIU to the other after each extension cycle.

In normal operation, the landing gears and doors are operated by the green hydraulic system.

In abnormal operation, the landing gears can be extended by the operation of electro-mechanical free-fall system. The related electrical switches in the cockpit disengages the doors and the landing gear uplocks. The landing gears then extend by free-fall and the downlock links of each landing gear (L/G) are locked in position by springs.

8. Braking

A. General

Carbon multi-disc brakes are installed on each wheel of the MLG. Each brake assembly has two wear indicators installed.

The braking system has four braking modes with autobrake and anti-skid systems:

- Normal braking with anti-skid,
- Alternate braking with anti-skid,
- Alternate braking without anti-skid,
- Parking brake with full brake pressure.

B. In-Flight Wheel Braking

Braking occurs automatically during the retraction of the landing gears. This stops the rotation of the MLG wheels before the landing gears go into their related bays.

The wheels of the NLG are braked by spring loaded pads.

9. Tire Pressure Indicating System (TPIS)

The TPIS automatically monitors the tire pressures and shows these values on Test Equipment (BITE) and also supplies other data and warnings on the WHEEL page of the System Display (SD).

10. Built In Test Equipment (BITE)

The BITE has hardware and software for these functions:

- to automatically do a self test at power-up,
- to continuously monitor the related systems for failures,
- to continuously monitor the interface with other specified systems in the aircraft,
- to keep a record of each failure and defect and send this data to other systems in the aircraft,
- to automatically do a functional test of some related systems before a landing,
- to do specified system tests during ground maintenance.

The BITE for the following systems is described in these chapters:

- The Brakes and Steering AMM 32-46-00,
- The TPIS AMM 32-49-00,
- The Landing Gear AMM 32-69-00.

**ON A/C A330-200 A330-200F A330-300 A330-800 A330-900

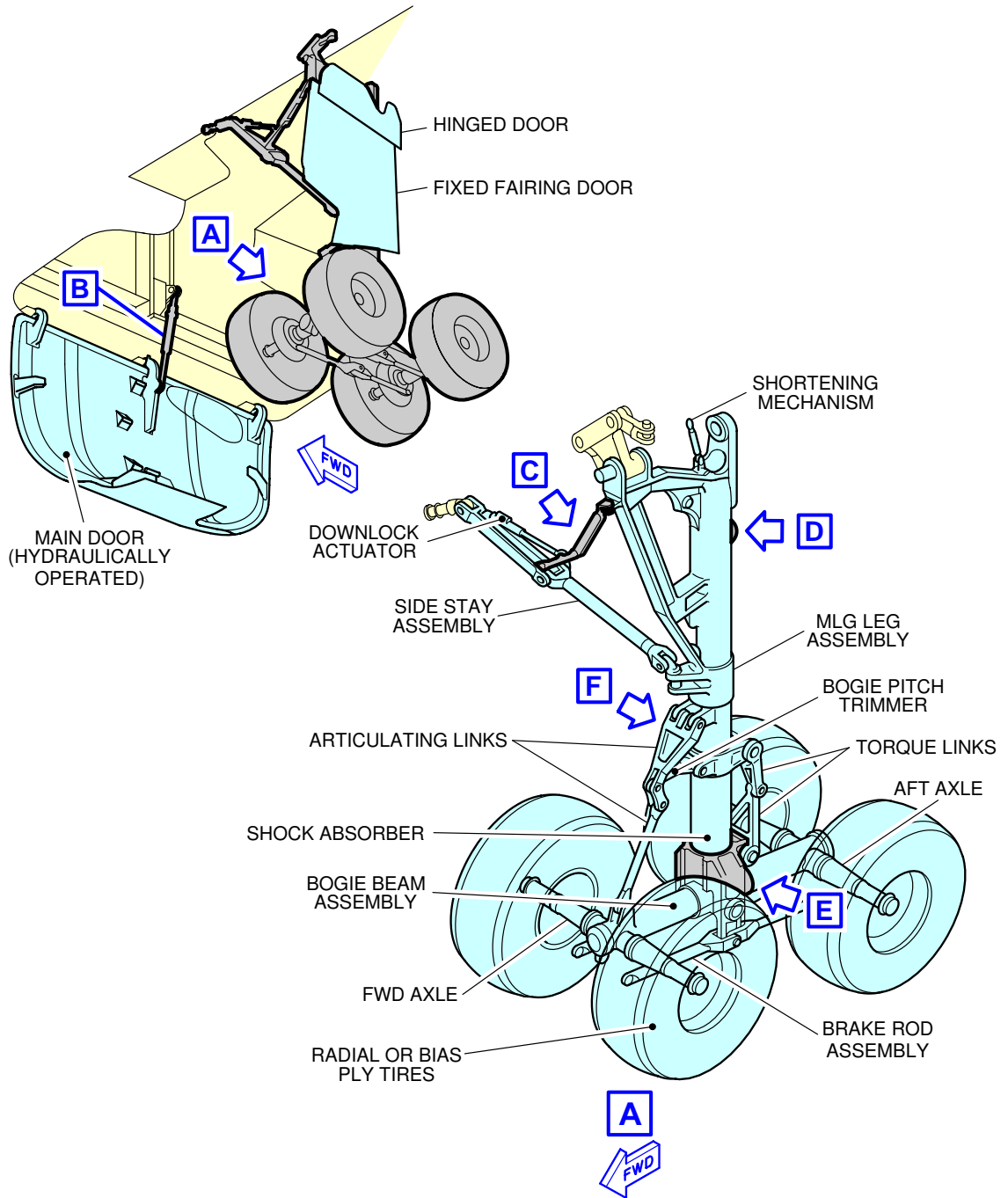

F_AC_020900_1_0070101_01_00

Main Landing Gear
 General (Sheet 1 of 3)
 FIGURE-2-9-0-991-007-A01

**ON A/C A330-200 A330-200F A330-300 A330-800 A330-900

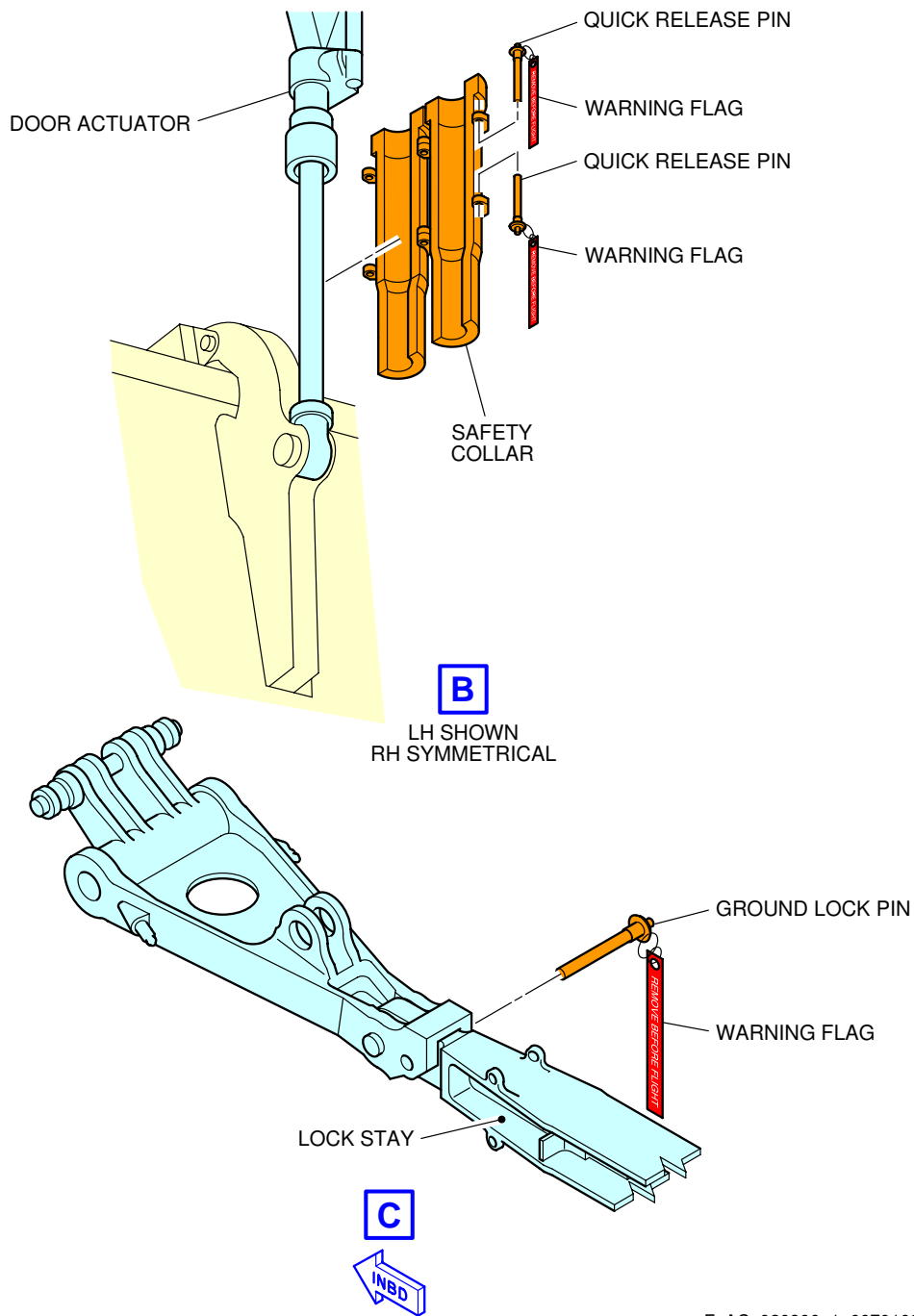

F_AC_020900_1_0070102_01_00

Main Landing Gear
Safety Devices (Sheet 2 of 3)
FIGURE-2-9-0-991-007-A01

**ON A/C A330-200 A330-200F A330-300 A330-800 A330-900

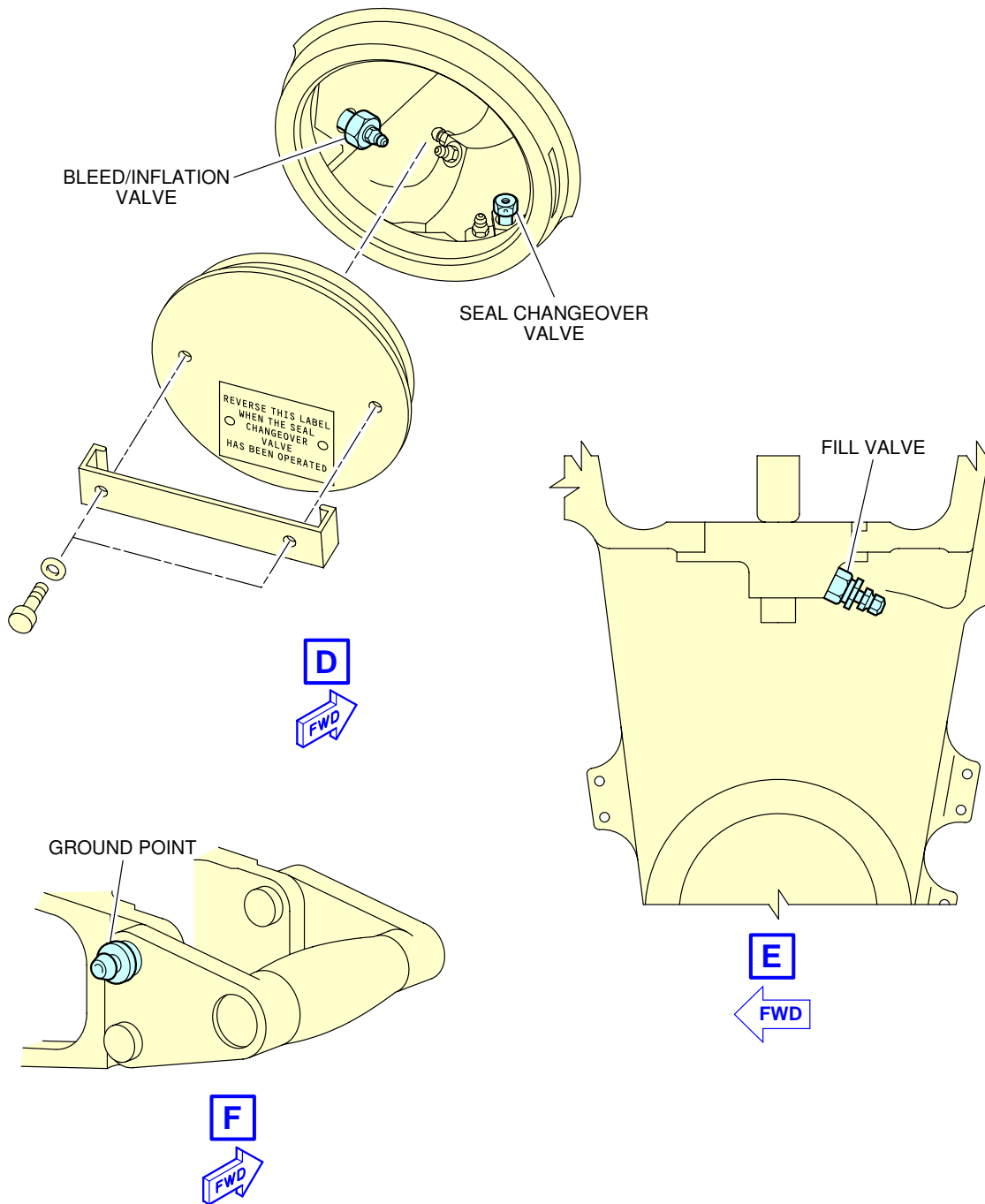

F_AC_020900_1_0070103_01_00

Main Landing Gear
Servicing (Sheet 3 of 3)
FIGURE-2-9-0-991-007-A01

****ON A/C A330-200 A330-200F A330-300 A330-800 A330-900**

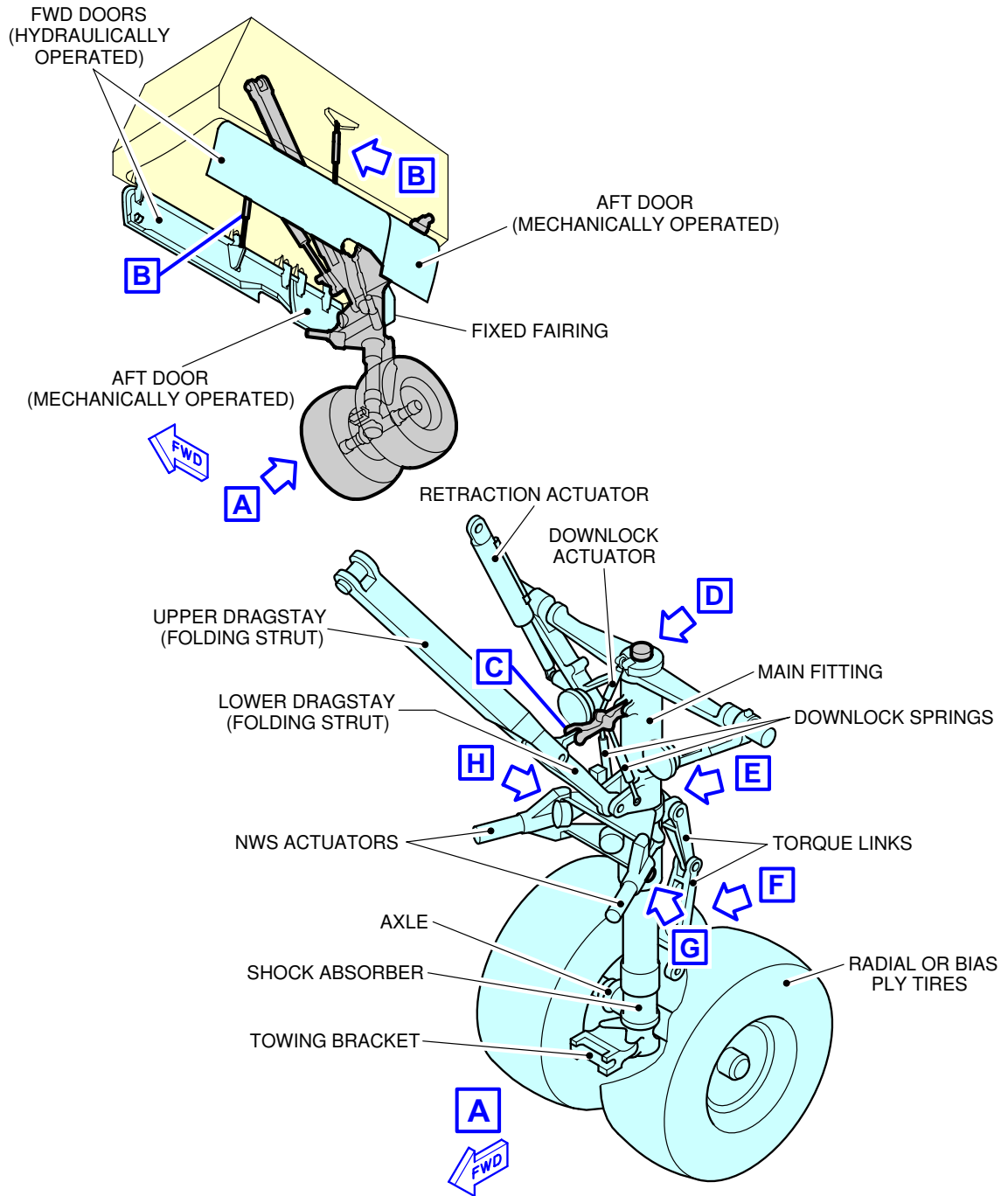

F_AC_020900_1_0080101_01_00

Nose Landing Gear
 General (Sheet 1 of 4)
 FIGURE-2-9-0-991-008-A01

**ON A/C A330-200 A330-200F A330-300 A330-800 A330-900

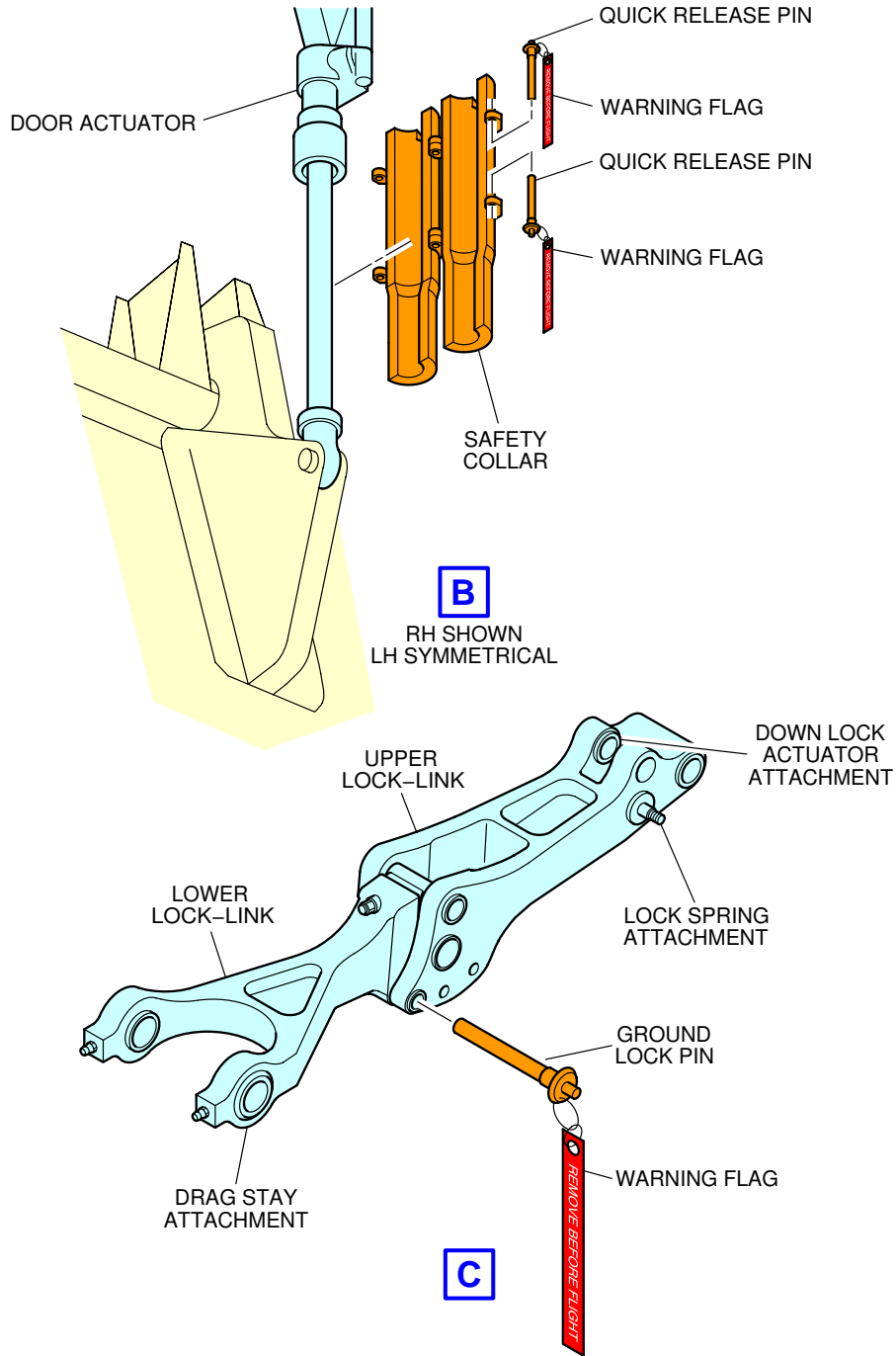

F_AC_020900_1_0080102_01_00

Nose Landing Gear
Safety Devices (Sheet 2 of 4)
FIGURE-2-9-0-991-008-A01

**ON A/C A330-200 A330-200F A330-300 A330-800 A330-900

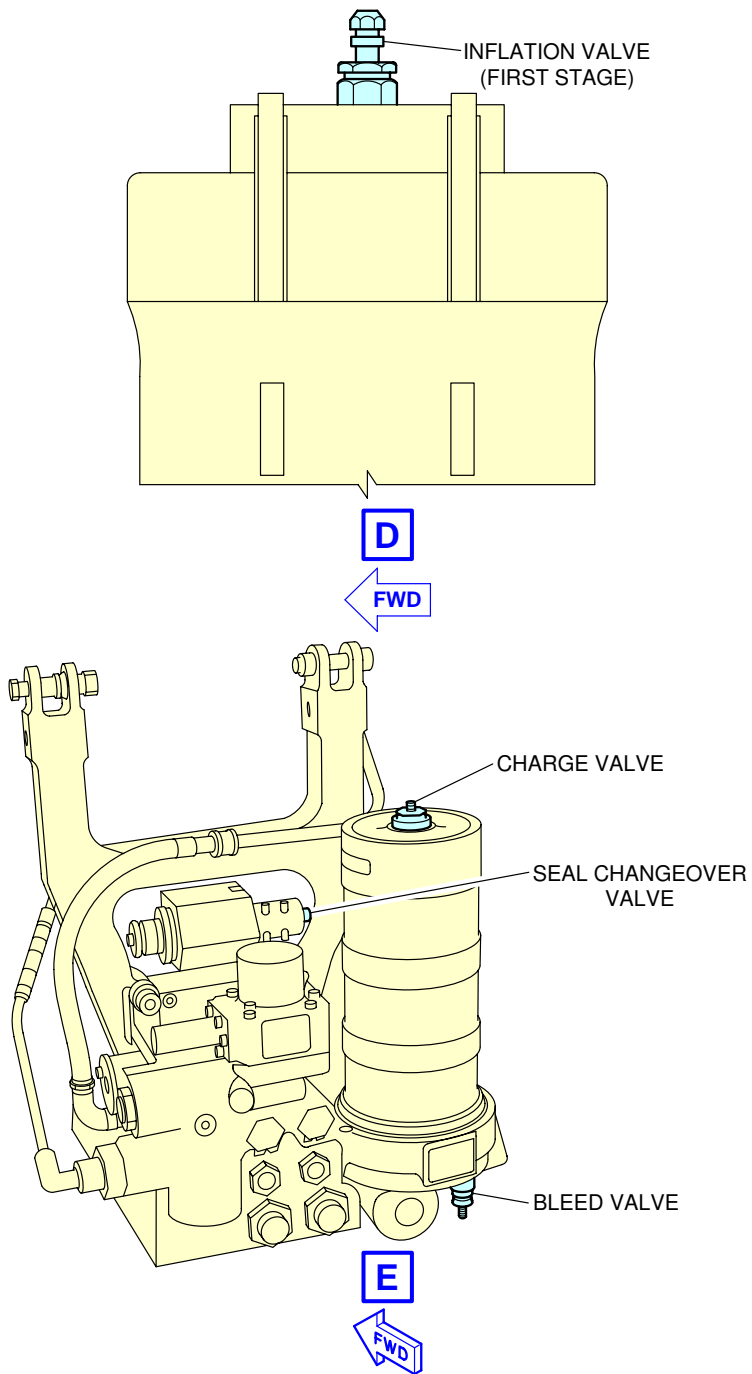

F_AC_020900_1_0080103_01_00

Nose Landing Gear
Servicing (Sheet 3 of 4)
FIGURE-2-9-0-991-008-A01

**ON A/C A330-200 A330-200F A330-300 A330-800 A330-900

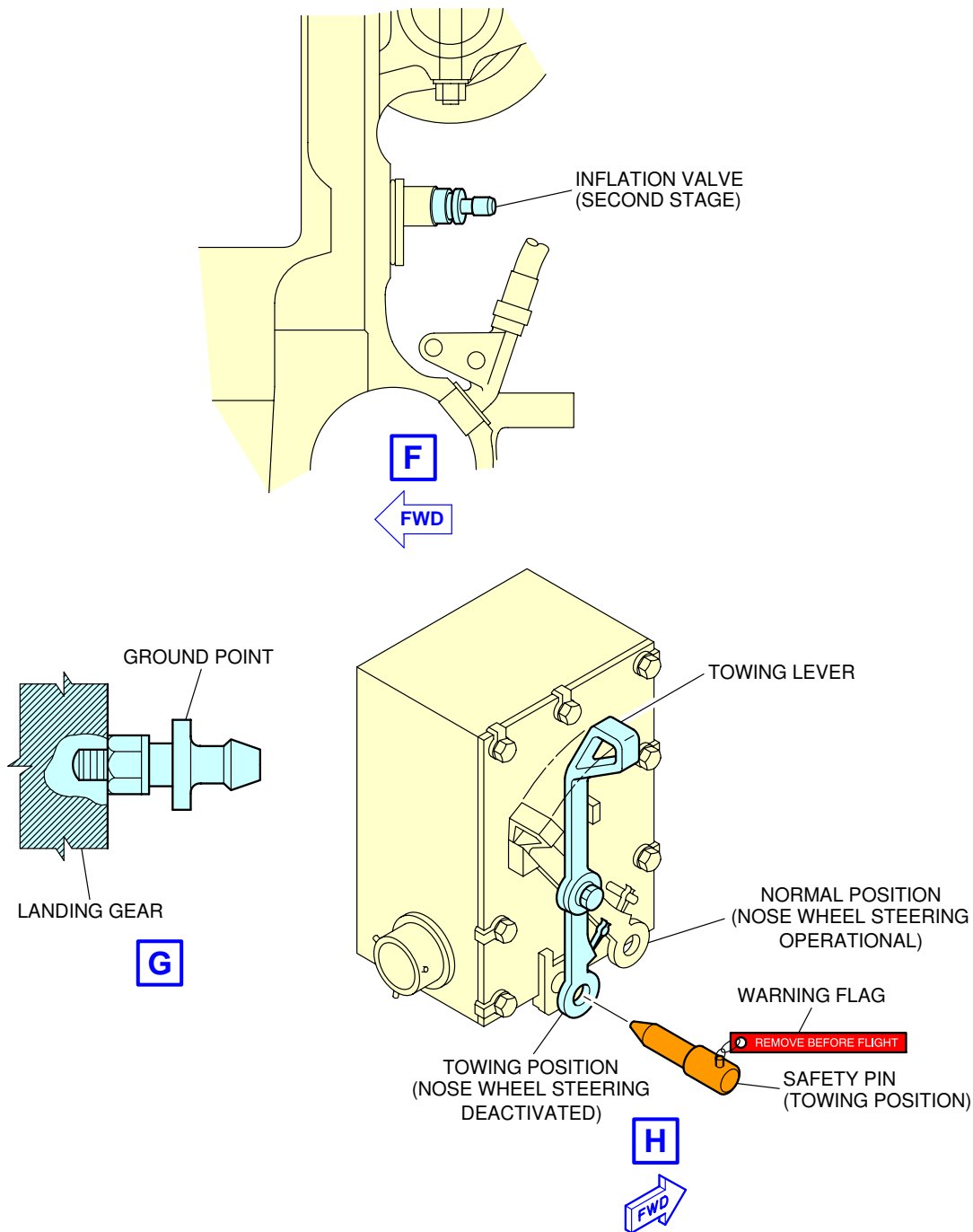

F_AC_020900_1_0080104_01_00

Nose Landing Gear
Servicing and Steering Disconnection Box (Sheet 4 of 4)
FIGURE-2-9-0-991-008-A01

**ON A/C A330-200 A330-200F A330-300 A330-800 A330-900

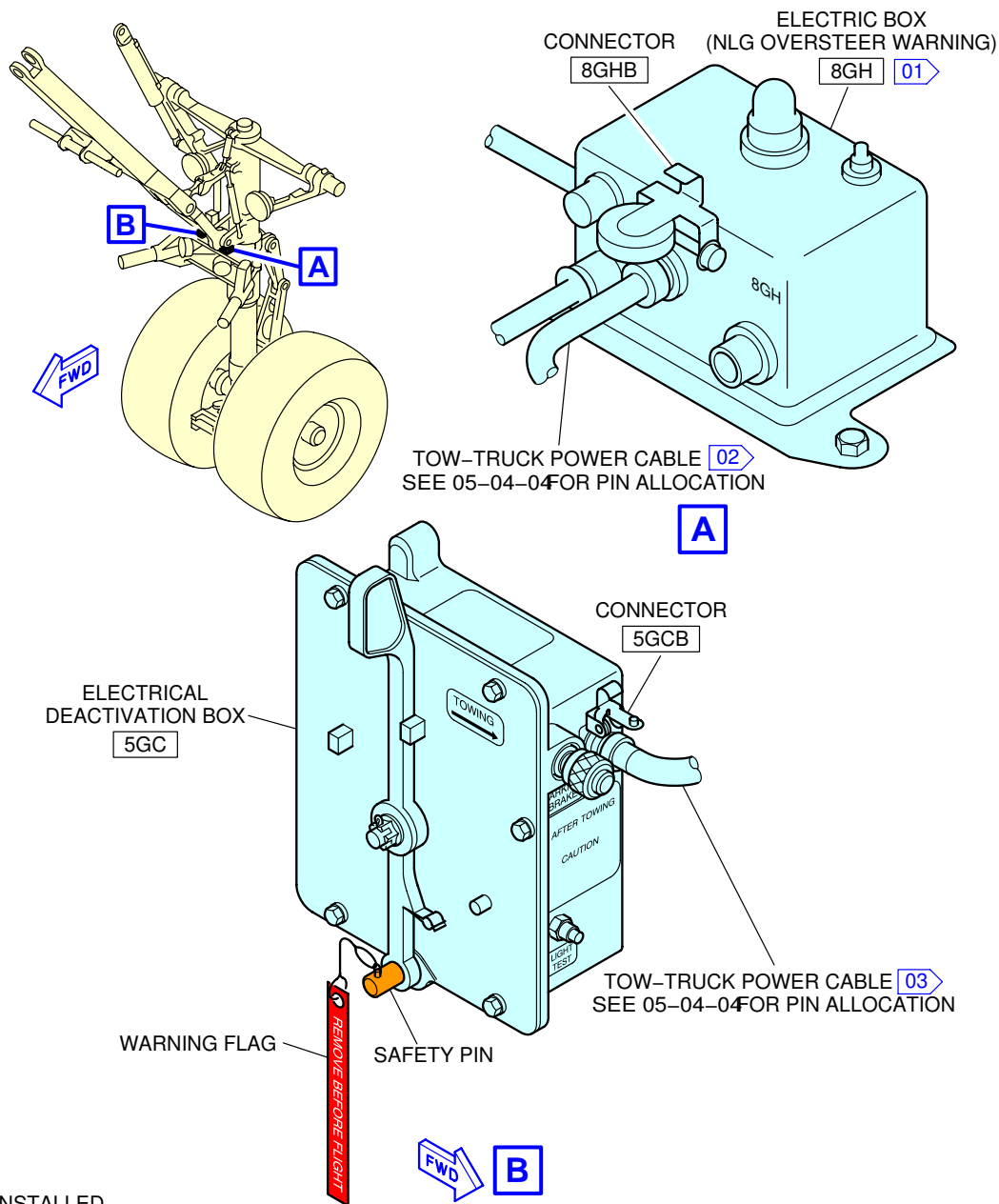

NOTE:

- 01 IF INSTALLED
- 02 CONNECT THE TOW-TRUCK POWER CABLE TO CONNECTOR 8GHB IF ELECTRICAL BOX 8GH IS INSTALLED ON THE AIRCRAFT.
- 03 IF ELECTRICAL BOX 8GH IS NOT INSTALLED, CONNECT THE TOW-TRUCK POWER CABLE TO CONNECTOR 5GCB ON ELECTRICAL DEACTIVATION BOX 5GC.

F_AC_020900_1_0150101_01_00

Tow Truck Power
FIGURE-2-9-0-991-015-A01

2-10-0 Exterior Lighting

****ON A/C A330-200 A330-200F A330-300 A330-800 A330-900**Exterior Lighting

1. General

This section provides the location of the aircraft exterior lighting.

EXTERIOR LIGHTING	
ITEM	DESCRIPTION
1	RIGHT NAVIGATION LIGHT (GREEN)
2	LEFT NAVIGATION LIGHT (RED)
3	TAIL NAVIGATION LIGHT (WHITE)
4	UPPER ANTI-COLLISION LIGHT/BEACON (RED)
5	LOWER ANTI-COLLISION LIGHT/BEACON (RED)
6	LOGO LIGHTS
7	ENGINE SCAN LIGHTS
8	WING SCAN LIGHTS
9	WING STROBE LIGHT (HIGH INTENSITY, WHITE)
10	TAIL STROBE LIGHT (HIGH INTENSITY, WHITE)
11	LANDING LIGHTS
12	RUNWAY TURN-OFF LIGHTS
13	TAXI LIGHTS
14	TAKE-OFF LIGHTS
15	CARGO COMPARTMENT FLOOD LIGHTS
16	LANDING GEAR BAY/WELL LIGHTS (DOME)
17 (A330-200F only)	CARGO COMPARTMENT FLOOD LIGHTS - MAIN DECK

**ON A/C A330-200

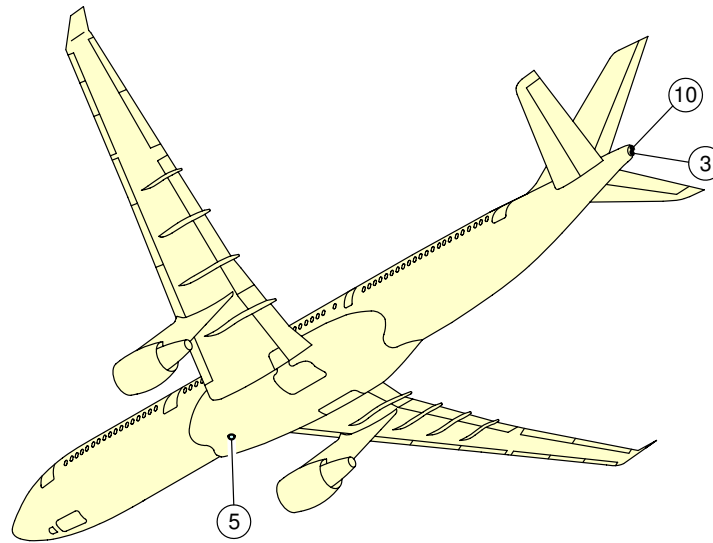
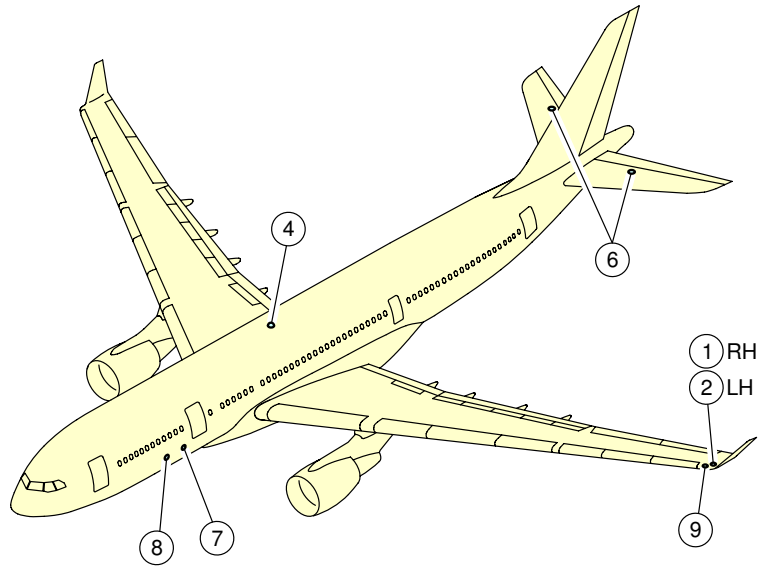

F_AC_021000_1_0010101_01_00

Exterior Lighting
(Sheet 1 of 5)
FIGURE-2-10-0-991-001-A01

****ON A/C A330-200**

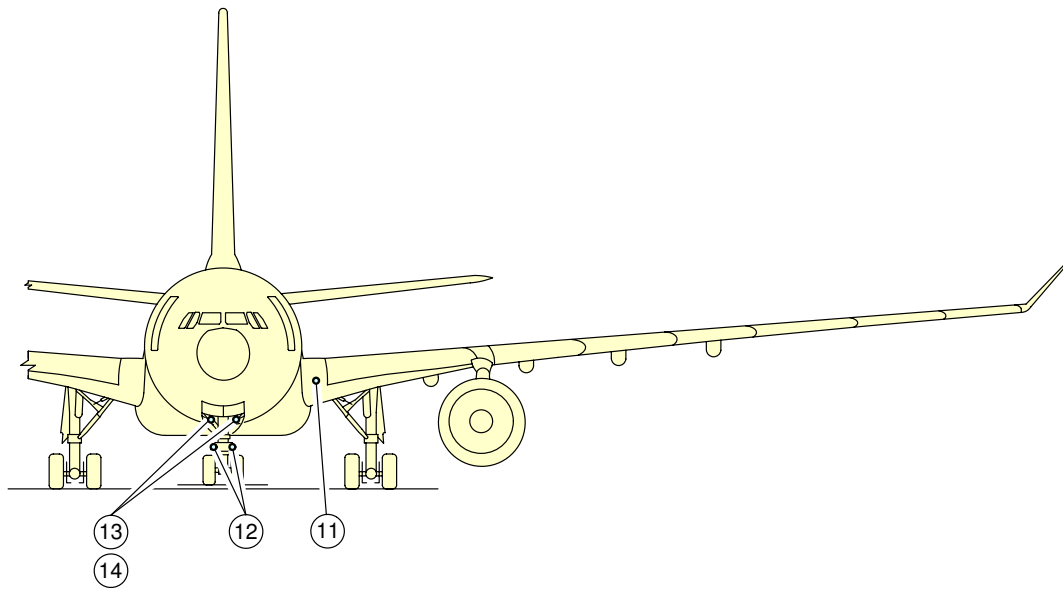

NOTE:

LIGHTS 13 AND 14 ARE THE SAME, BUT THEY OPERATE WITH DIFFERENT POWER SETTINGS.

F_AC_021000_1_0010102_01_00

Exterior Lighting
(Sheet 2 of 5)
FIGURE-2-10-0-991-001-A01

**ON A/C A330-200

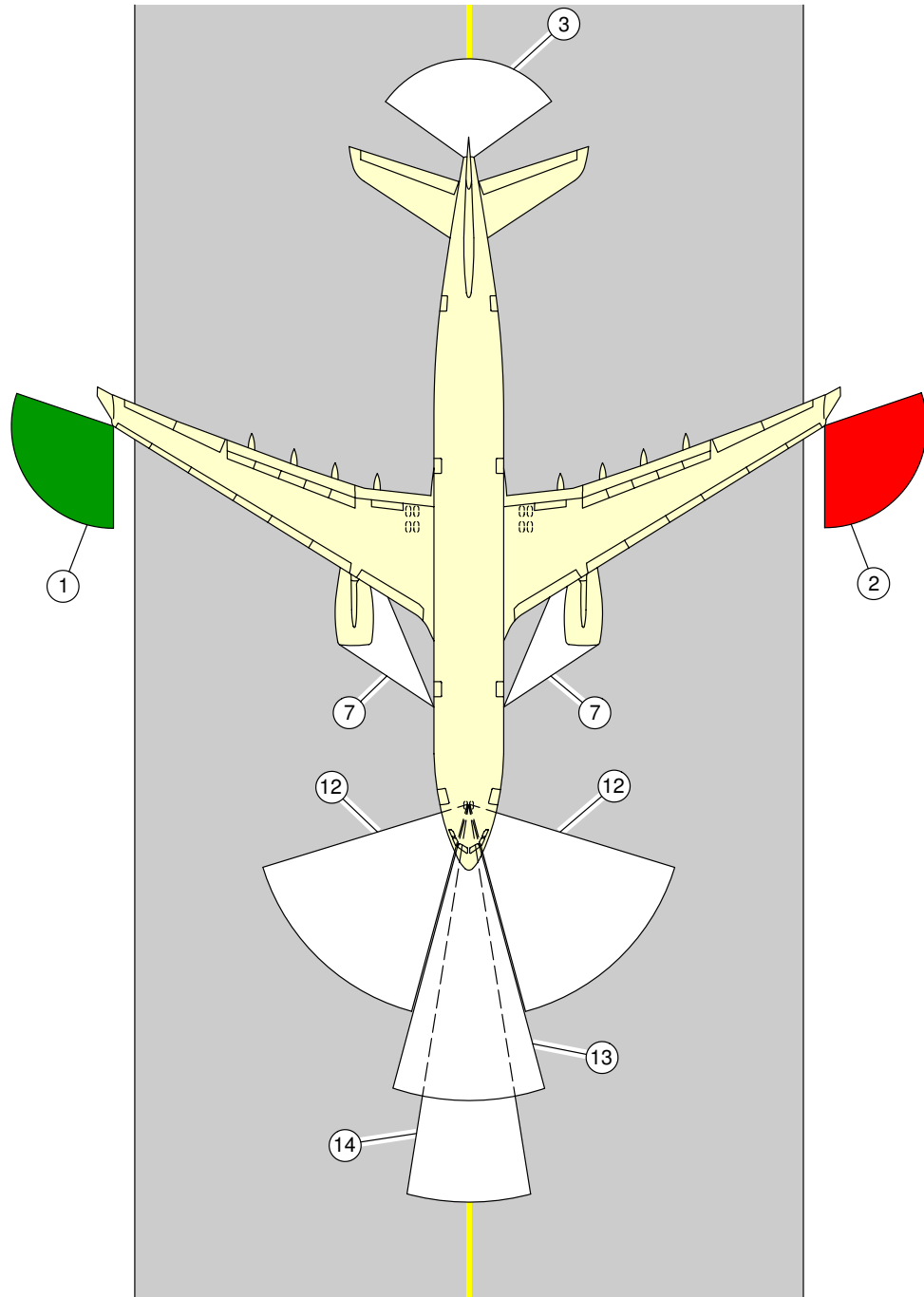

F_AC_021000_1_0010103_01_00

Exterior Lighting
(Sheet 3 of 5)
FIGURE-2-10-0-991-001-A01

**ON A/C A330-200

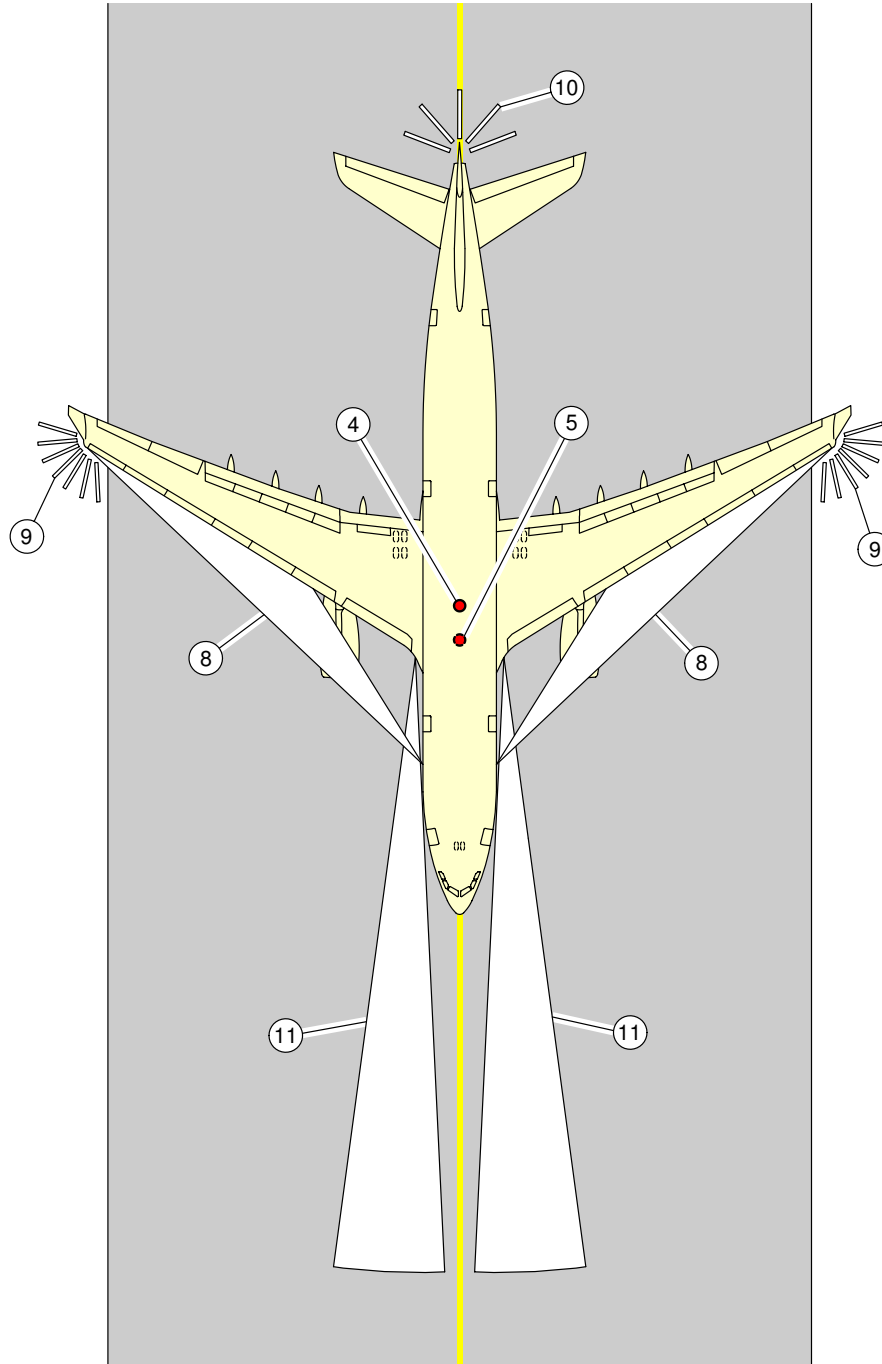

F_AC_021000_1_0010104_01_00

Exterior Lighting
(Sheet 4 of 5)
FIGURE-2-10-0-991-001-A01

**ON A/C A330-200

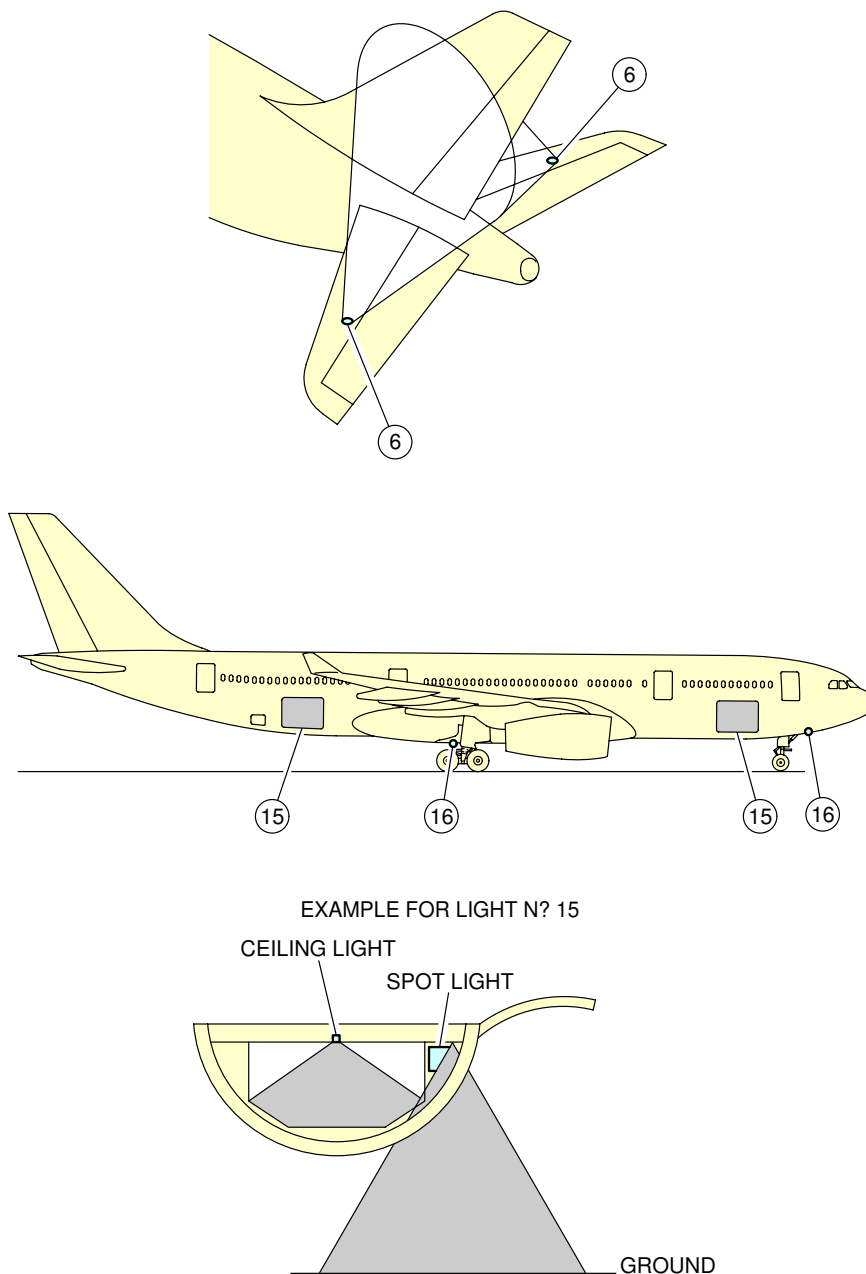

F_AC_021000_1_0010105_01_00

Exterior Lighting
(Sheet 5 of 5)
FIGURE-2-10-0-991-001-A01

**ON A/C A330-200F

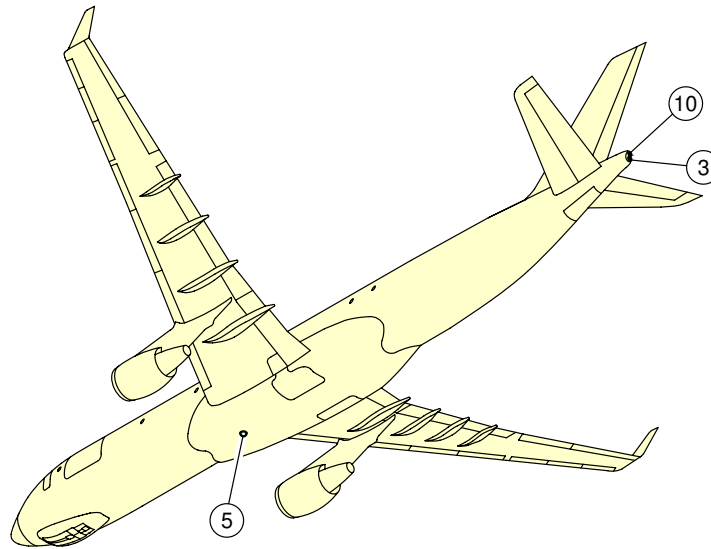
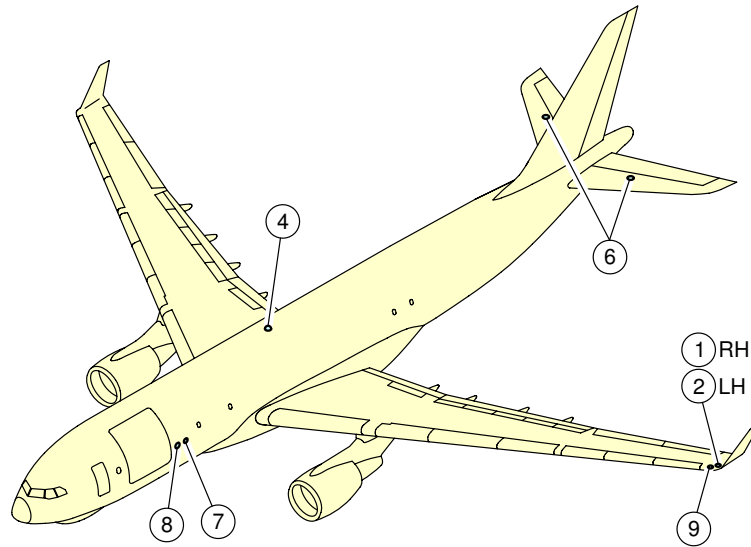

F_AC_021000_1_0020101_01_00

Exterior Lighting
(Sheet 1 of 6)
FIGURE-2-10-0-991-002-A01

****ON A/C A330-200F**

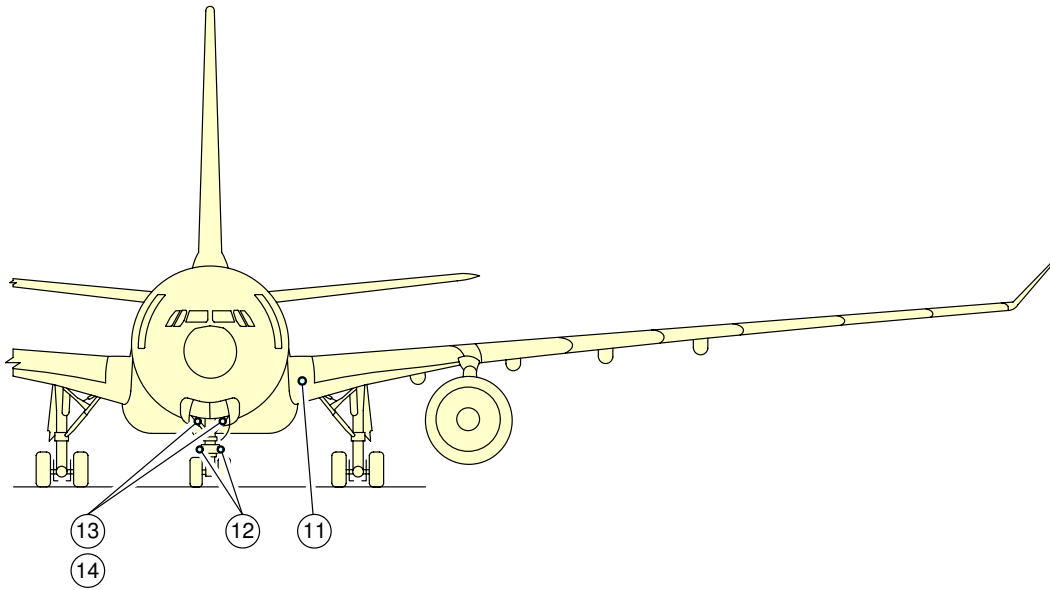

NOTE:

LIGHTS 13 AND 14 ARE THE SAME, BUT THEY OPERATE WITH DIFFERENT POWER SETTINGS.

F_AC_021000_1_0020102_01_00

Exterior Lighting
(Sheet 2 of 6)
FIGURE-2-10-0-991-002-A01

**ON A/C A330-200F

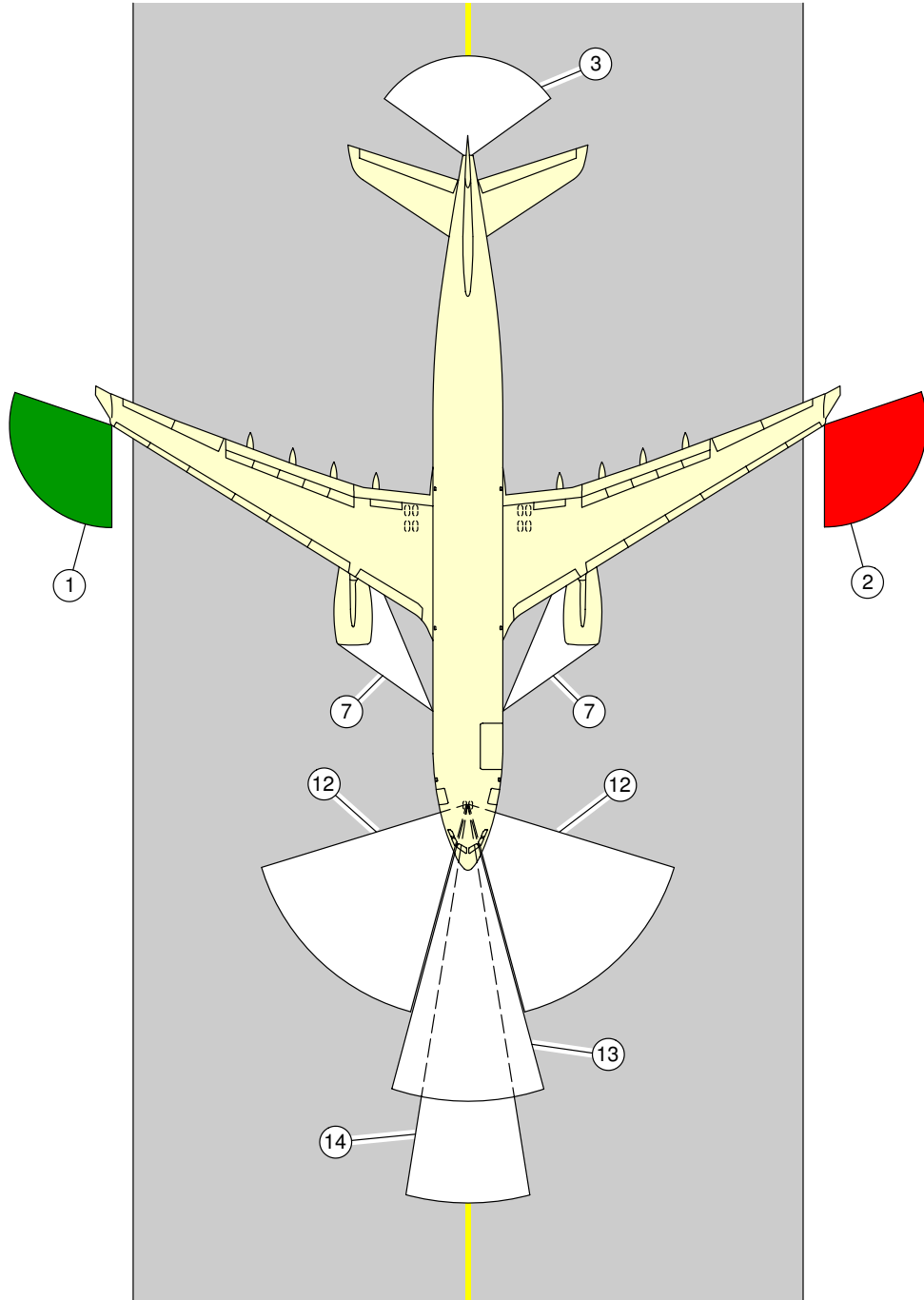

F_AC_021000_1_0020103_01_00

Exterior Lighting
(Sheet 3 of 6)
FIGURE-2-10-0-991-002-A01

**ON A/C A330-200F

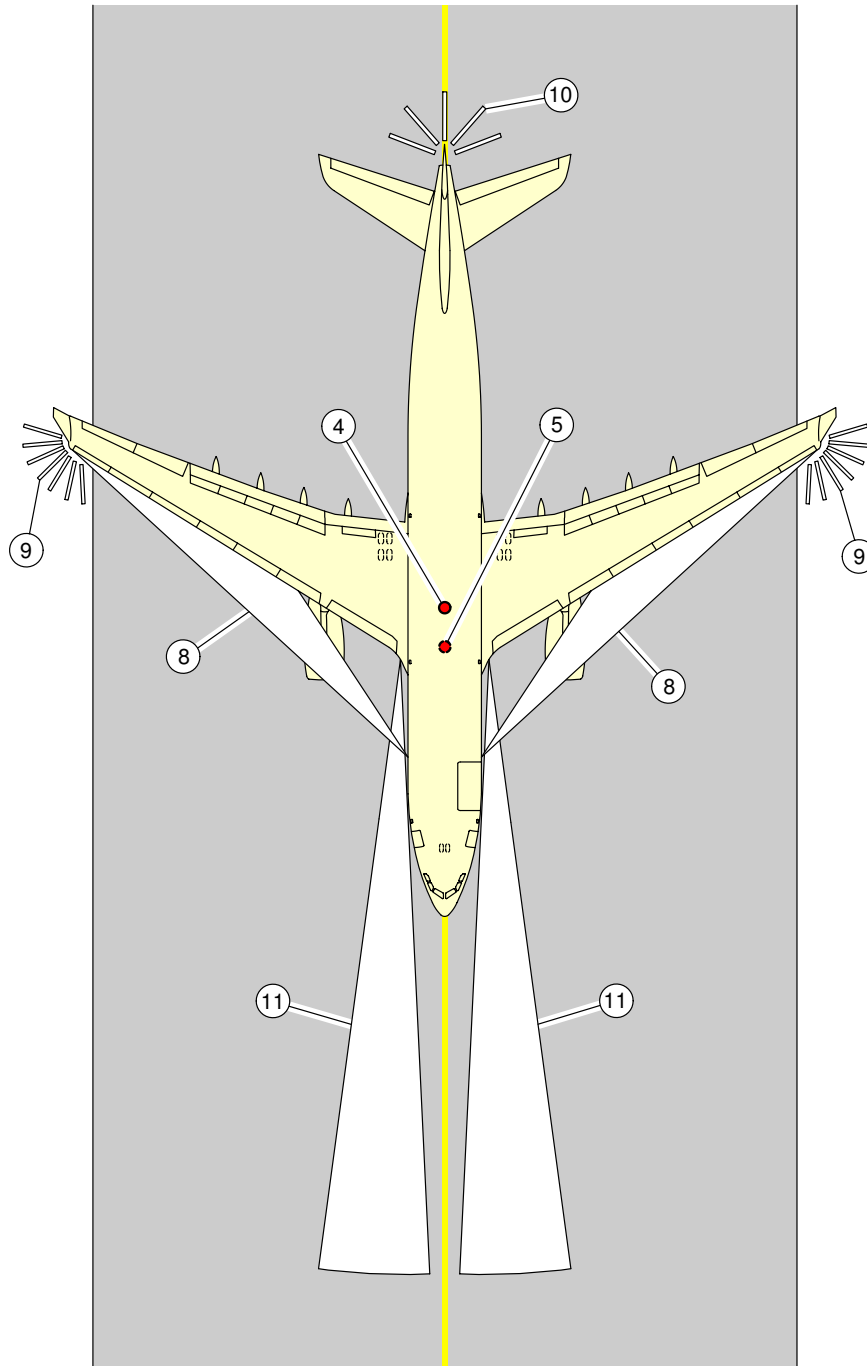

F_AC_021000_1_0020104_01_00

Exterior Lighting
(Sheet 4 of 6)
FIGURE-2-10-0-991-002-A01

**ON A/C A330-200F

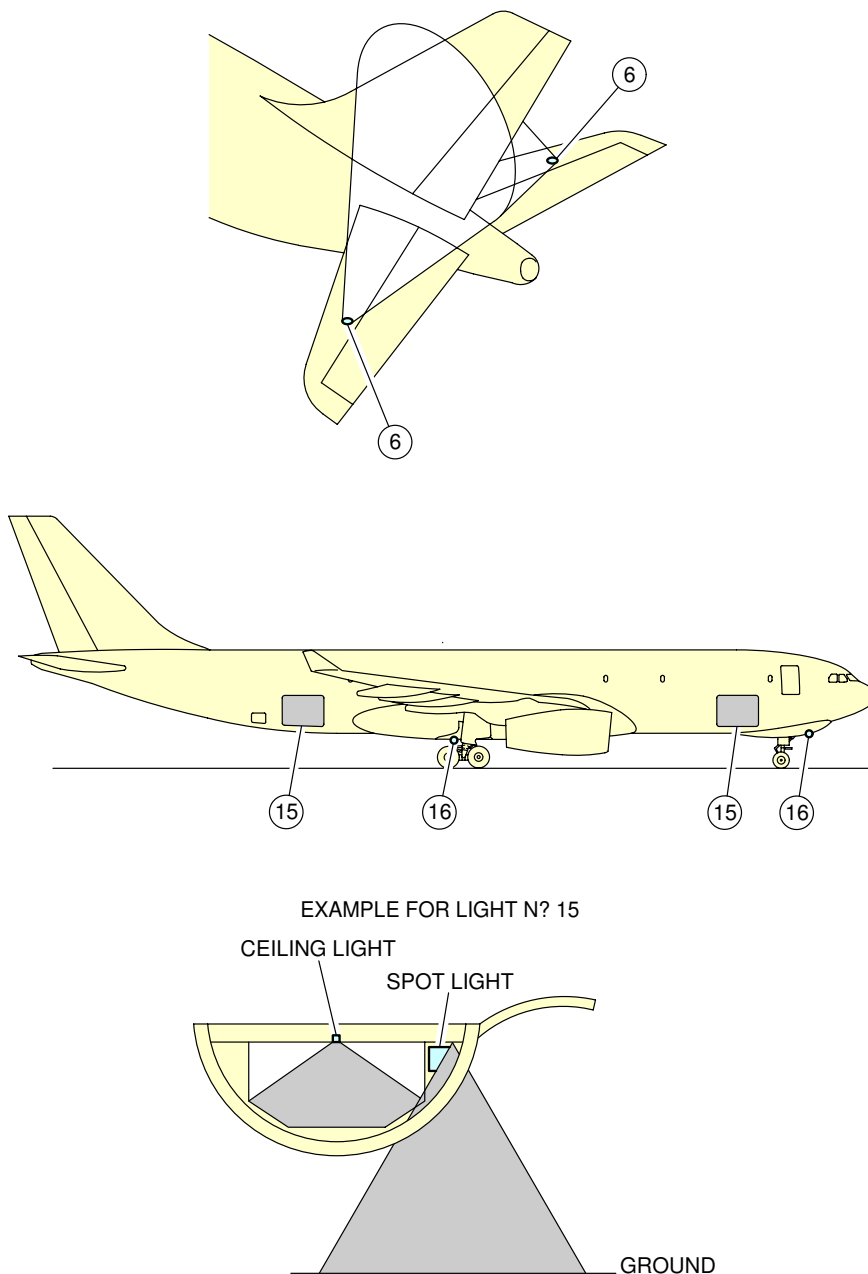

F_AC_021000_1_0020105_01_00

Exterior Lighting
(Sheet 5 of 6)
FIGURE-2-10-0-991-002-A01

**ON A/C A330-200F

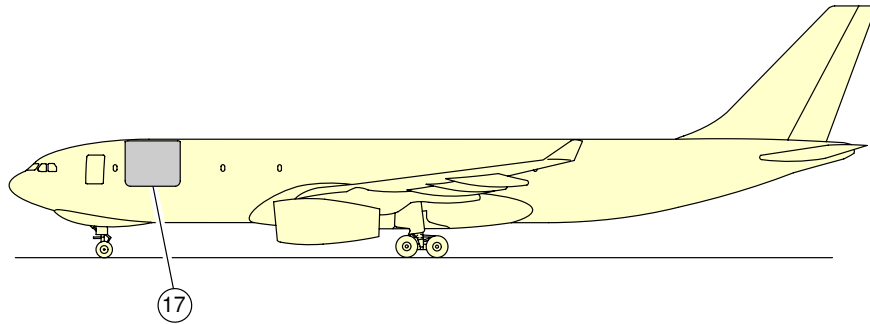

EXAMPLE FOR LIGHT N° 17

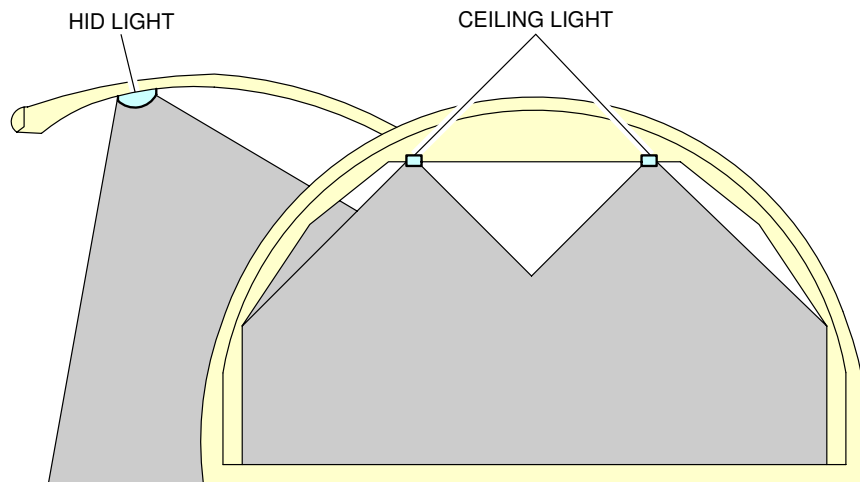

F_AC_021000_1_0020106_01_00

Exterior Lighting
(Sheet 6 of 6)
FIGURE-2-10-0-991-002-A01

**ON A/C A330-300

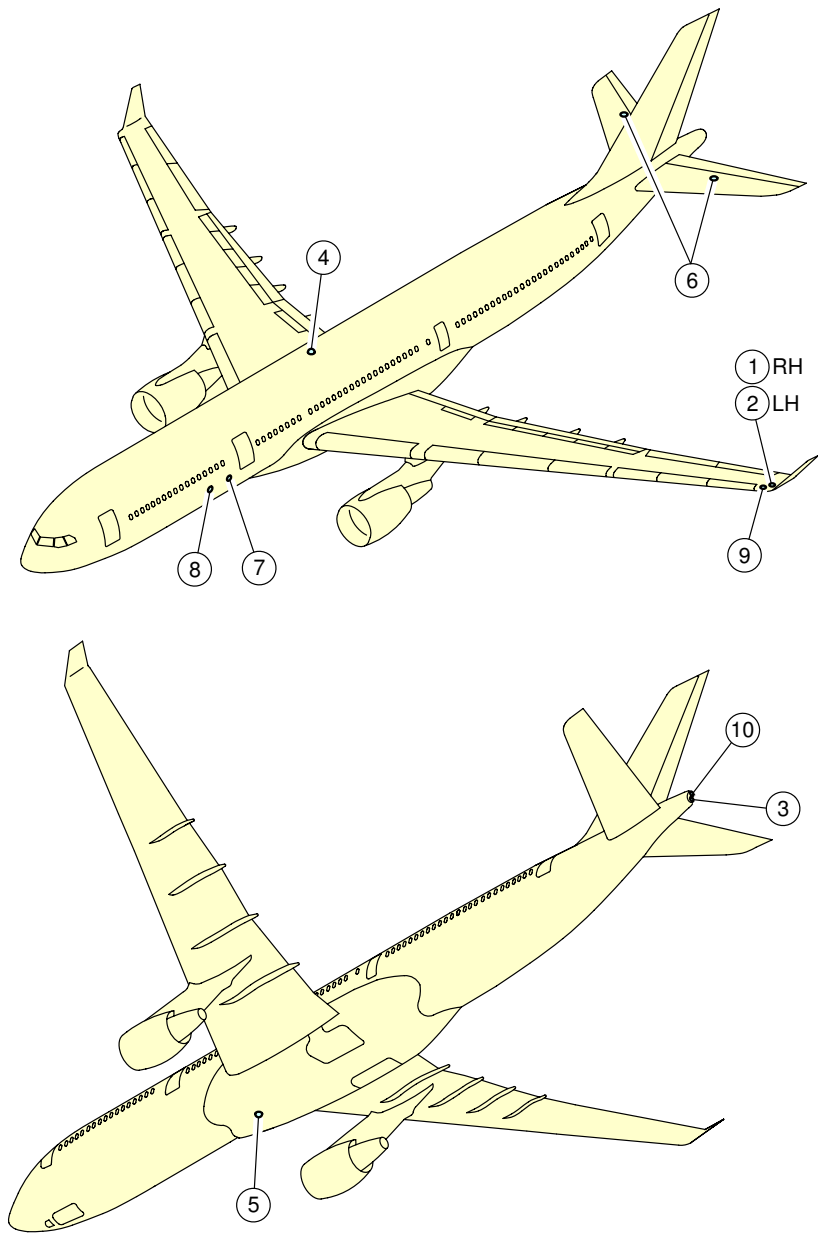

F_AC_021000_1_0030101_01_00

Exterior Lighting
(Sheet 1 of 5)
FIGURE-2-10-0-991-003-A01

****ON A/C A330-300**

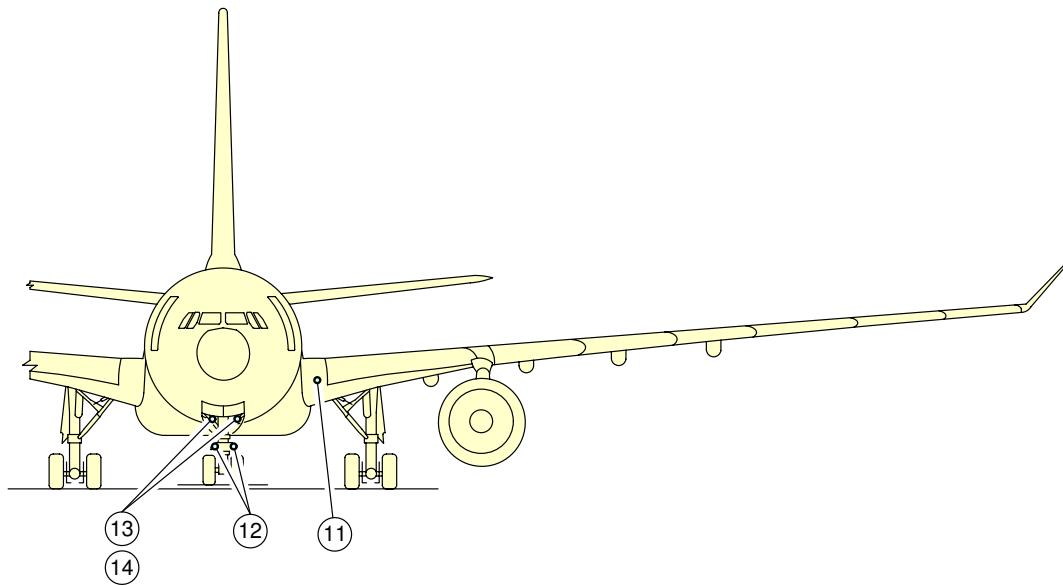

NOTE:

LIGHTS 13 AND 14 ARE THE SAME, BUT THEY OPERATE WITH DIFFERENT POWER SETTINGS.

F_AC_021000_1_0030102_01_00

Exterior Lighting
(Sheet 2 of 5)
FIGURE-2-10-0-991-003-A01

****ON A/C A330-300**

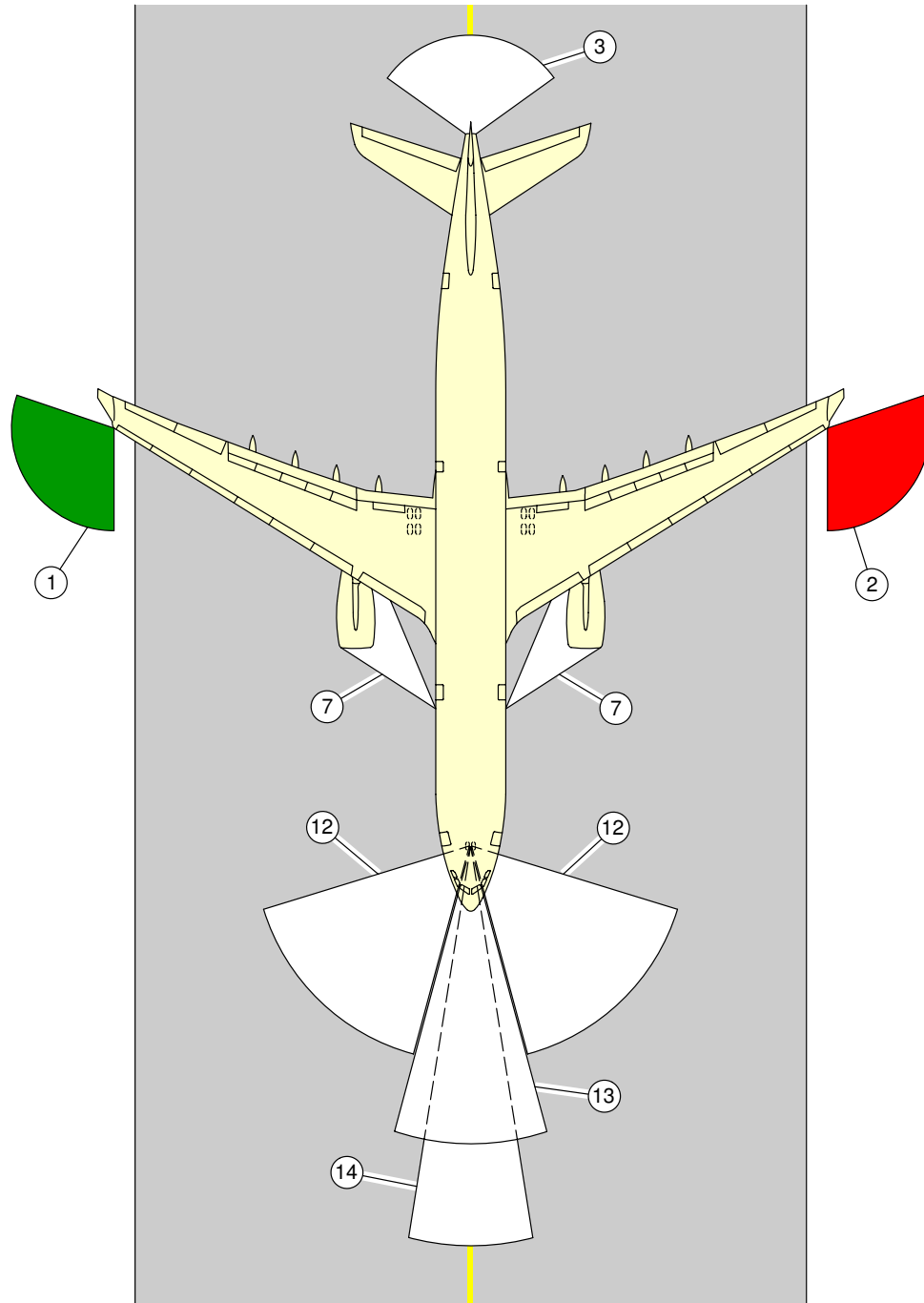

F_AC_021000_1_0030103_01_00

Exterior Lighting
(Sheet 3 of 5)
FIGURE-2-10-0-991-003-A01

**ON A/C A330-300

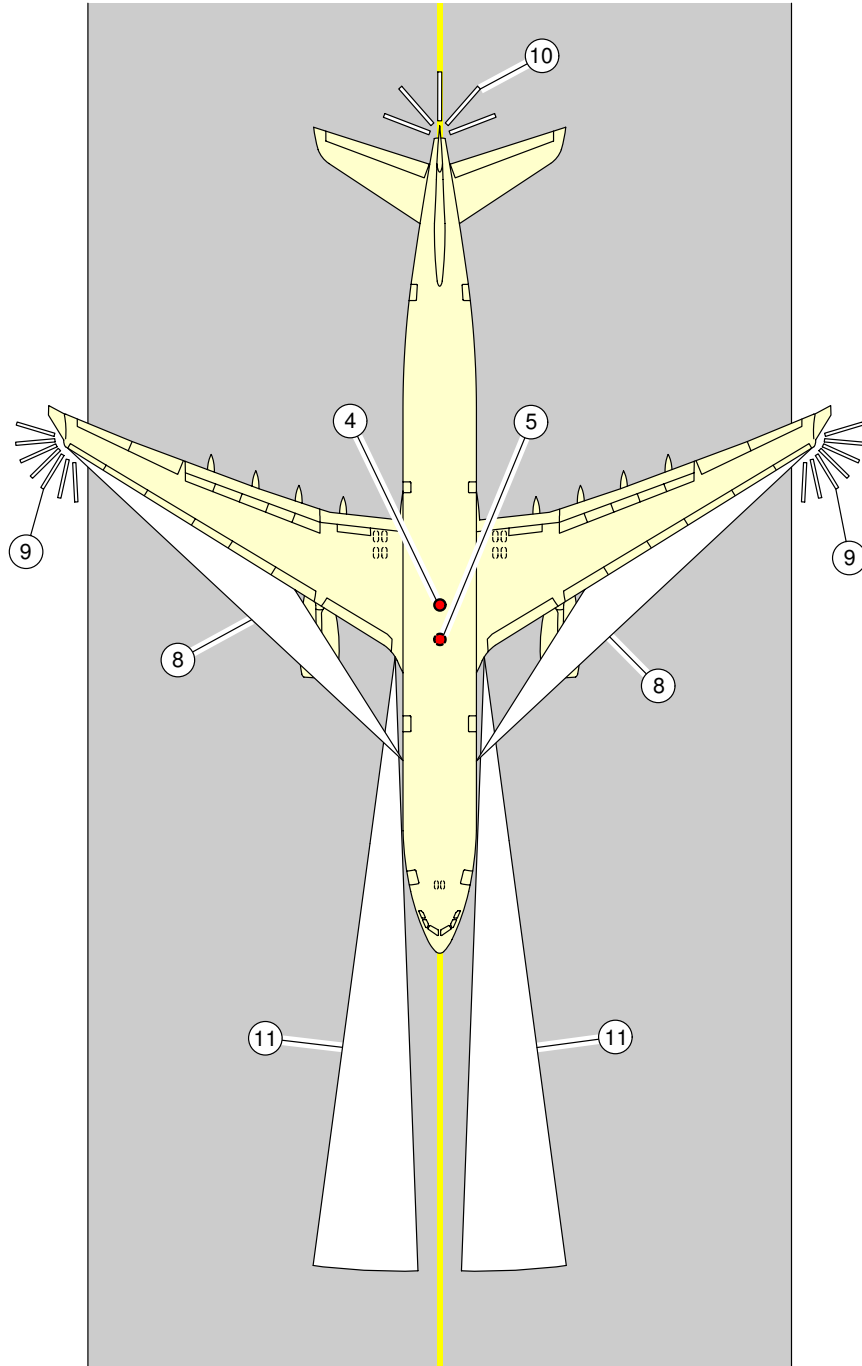

F_AC_021000_1_0030104_01_00

Exterior Lighting
(Sheet 4 of 5)
FIGURE-2-10-0-991-003-A01

**ON A/C A330-300

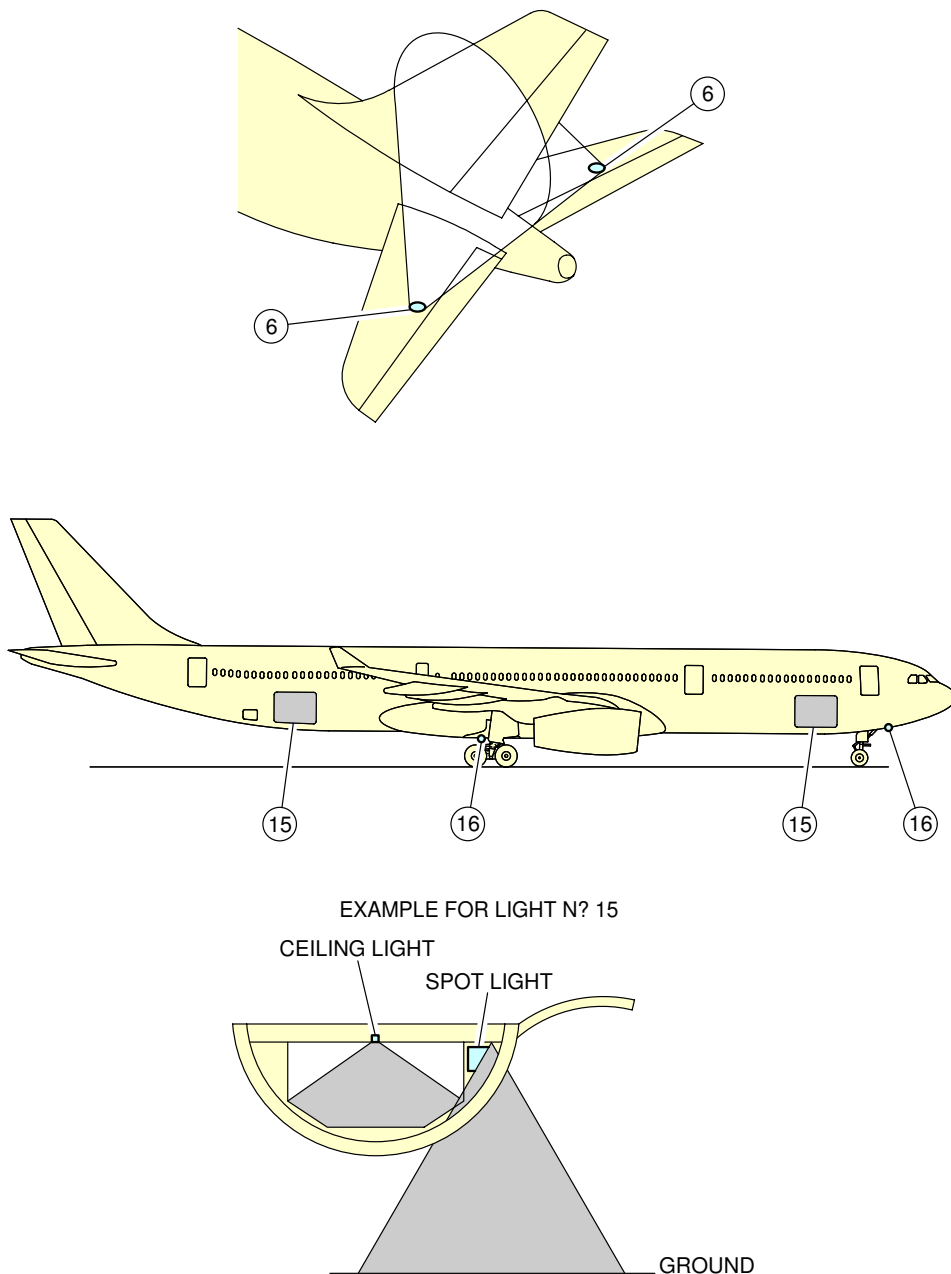

F_AC_021000_1_0030105_01_00

Exterior Lighting
(Sheet 5 of 5)
FIGURE-2-10-0-991-003-A01

**ON A/C A330-800

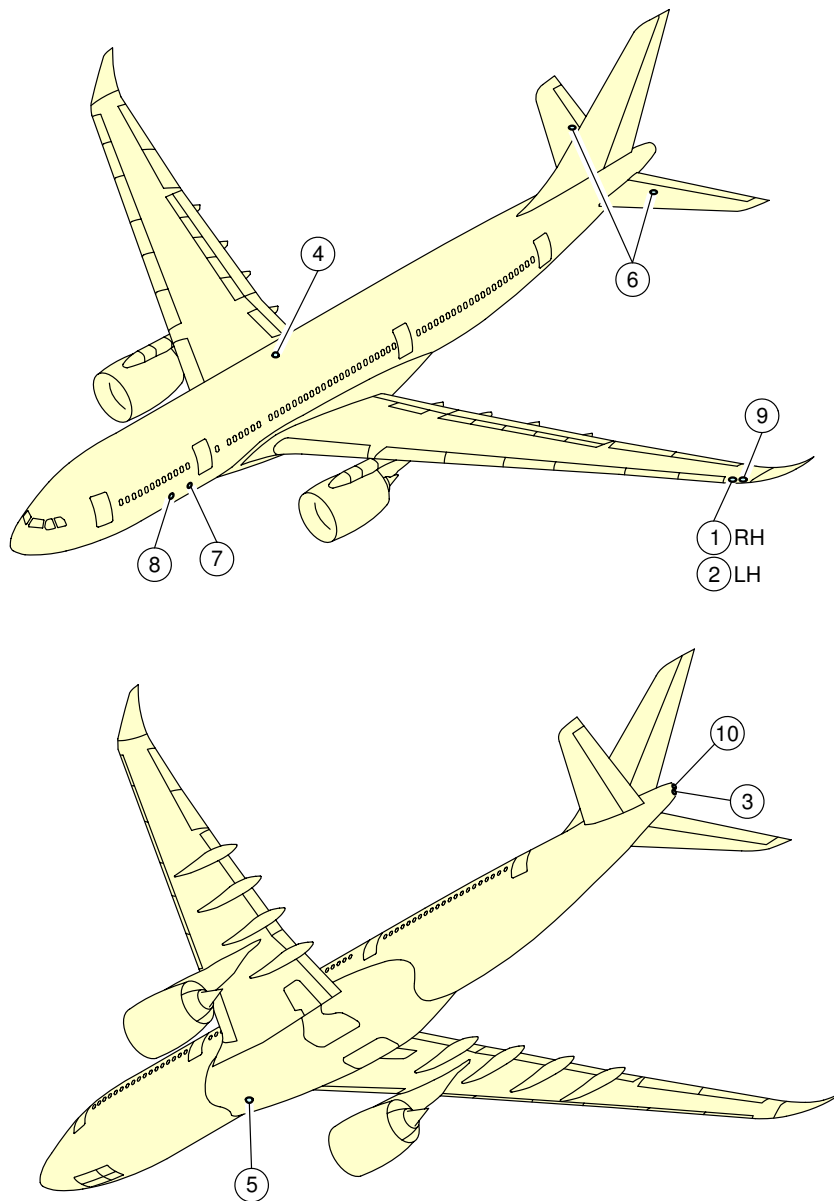

F_AC_021000_1_0080101_01_00

Exterior Lighting
(Sheet 1 of 5)
FIGURE-2-10-0-991-008-A01

****ON A/C A330-800**

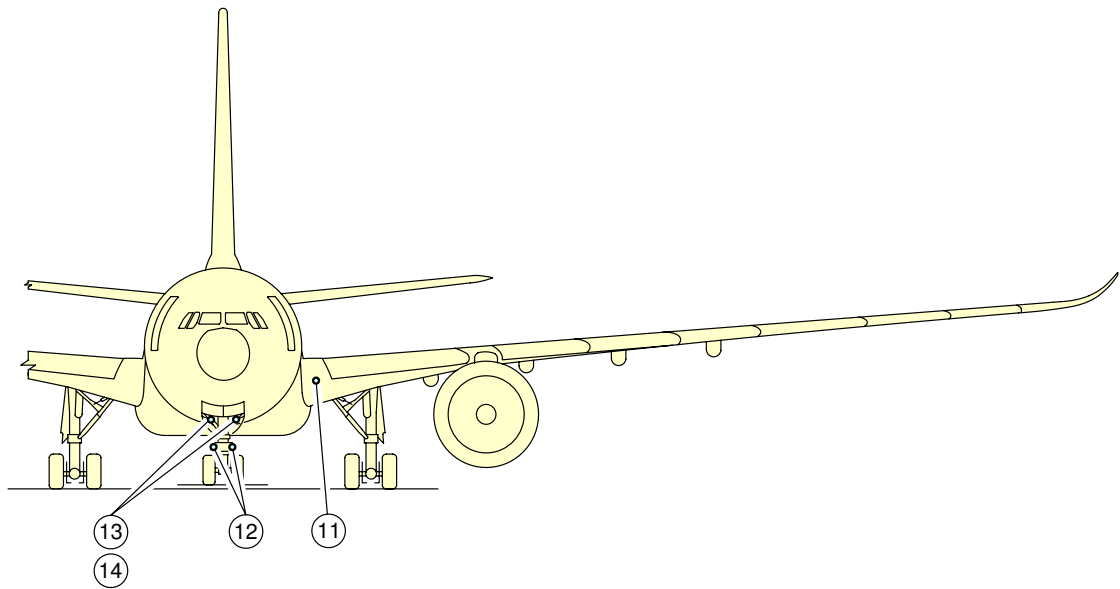

NOTE:

LIGHTS 13 AND 14 ARE THE SAME, BUT THEY OPERATE WITH DIFFERENT POWER SETTINGS.

F_AC_021000_1_0080102_01_00

Exterior Lighting
(Sheet 2 of 5)
FIGURE-2-10-0-991-008-A01

**ON A/C A330-800

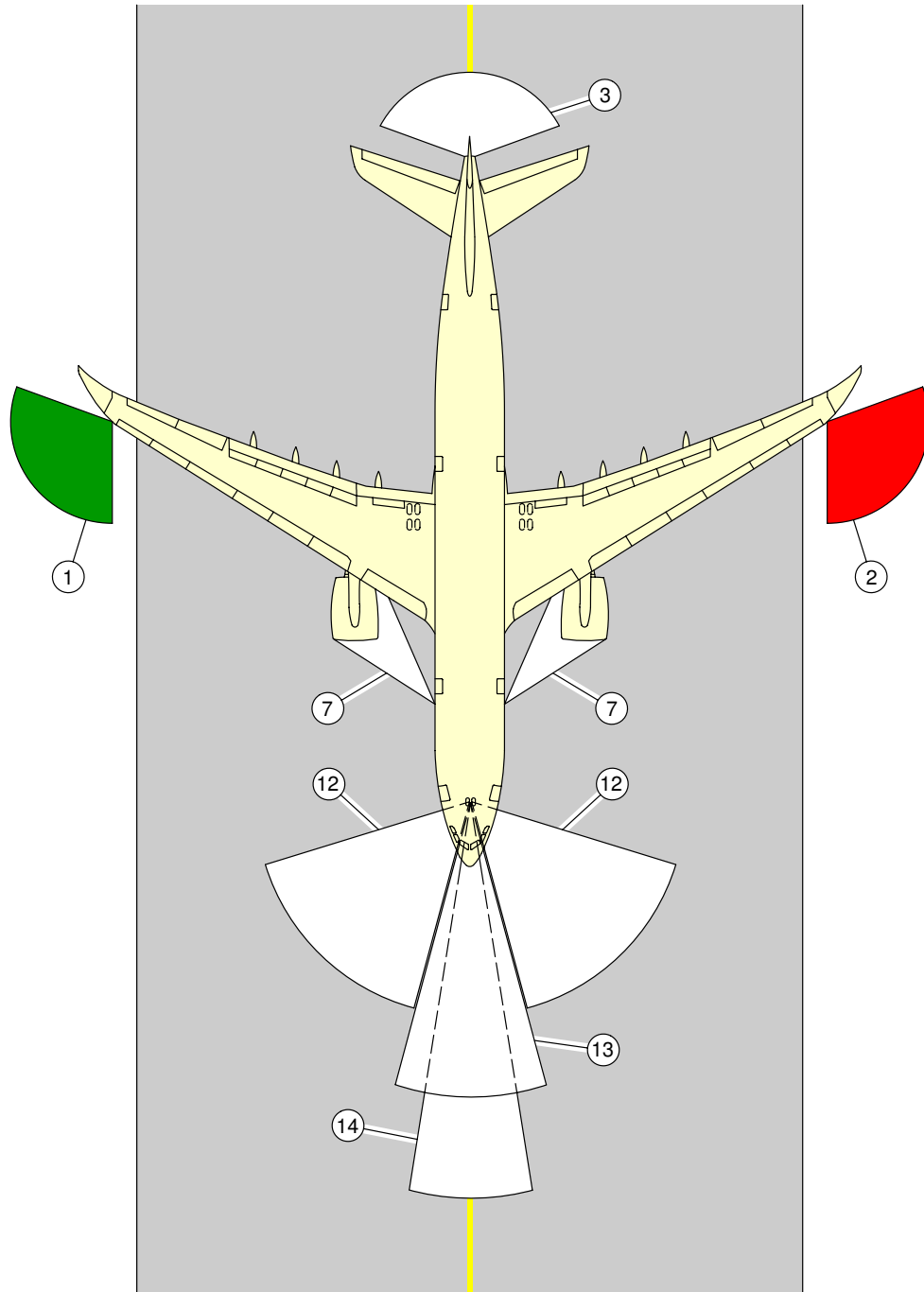

F_AC_021000_1_0080103_01_00

Exterior Lighting
(Sheet 3 of 5)
FIGURE-2-10-0-991-008-A01

****ON A/C A330-800**

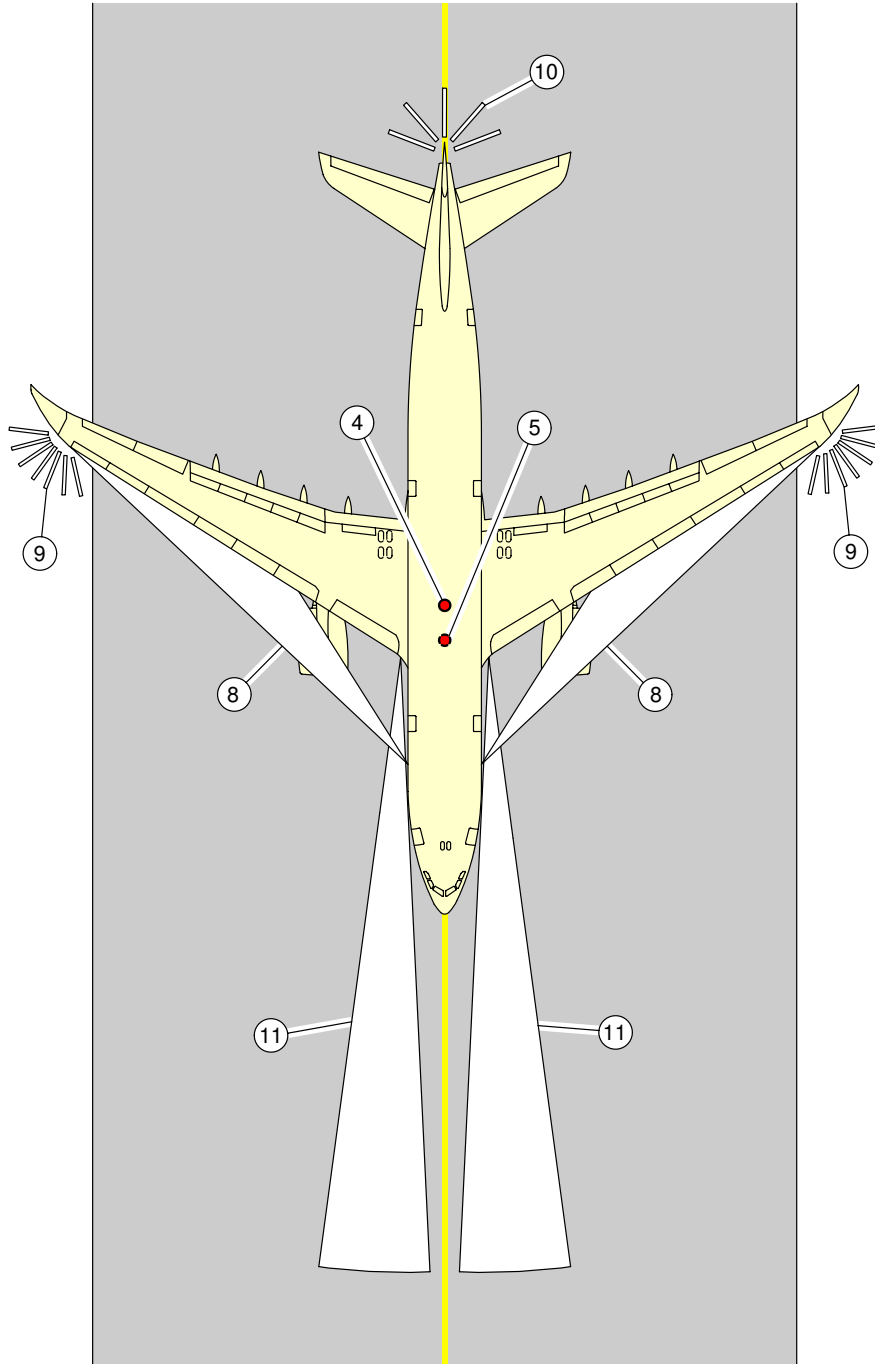

F_AC_021000_1_0080104_01_00

Exterior Lighting
(Sheet 4 of 5)
FIGURE-2-10-0-991-008-A01

**ON A/C A330-800

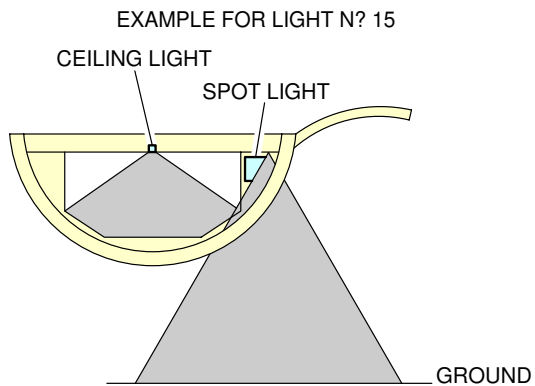
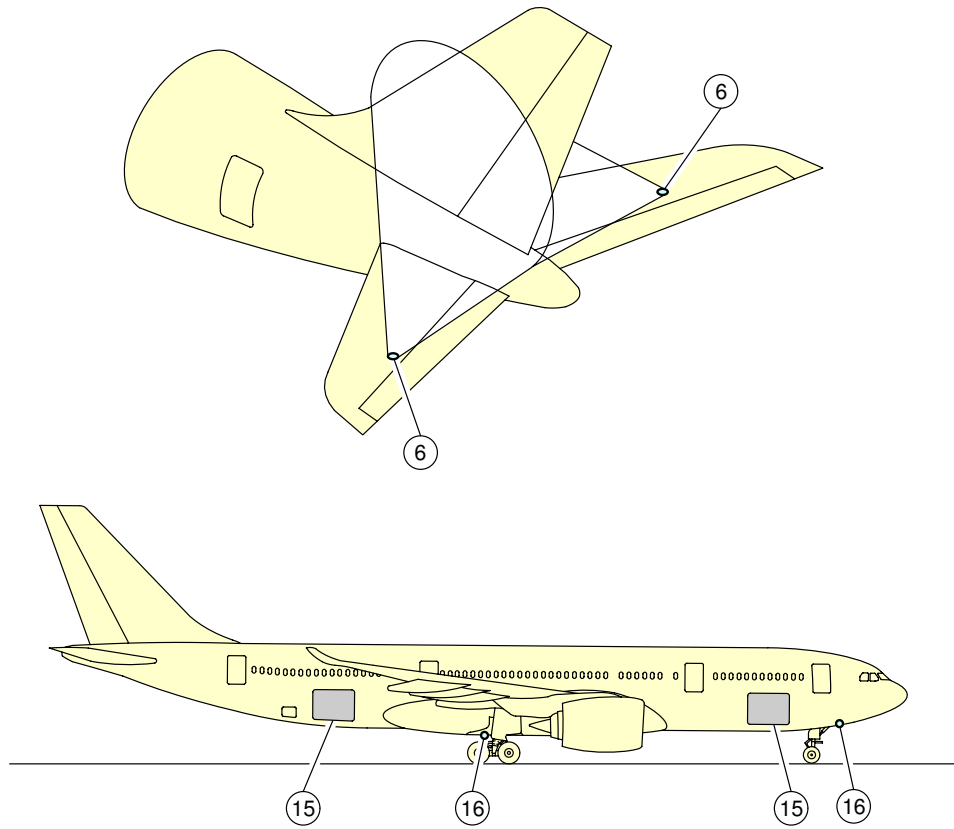

F_AC_021000_1_0080105_01_00

Exterior Lighting
(Sheet 5 of 5)
FIGURE-2-10-0-991-008-A01

**ON A/C A330-900

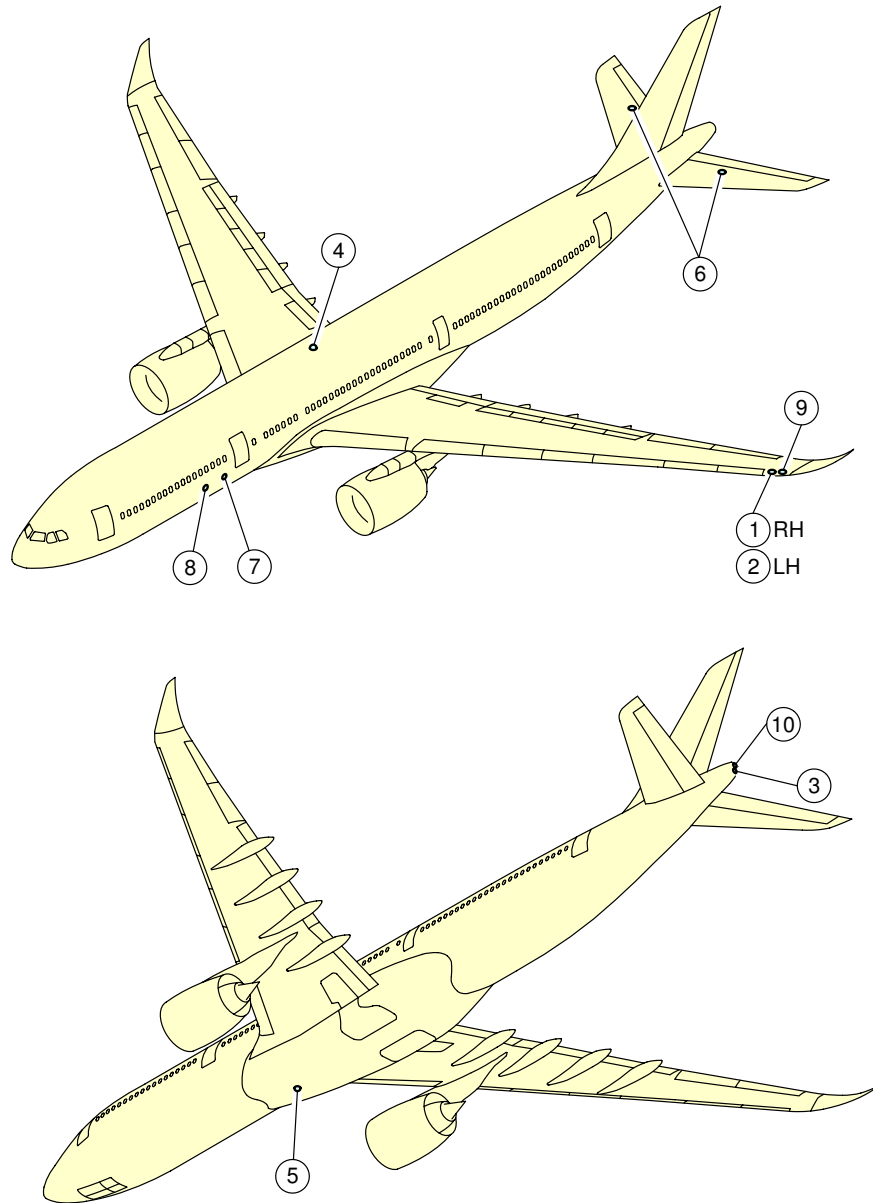

F_AC_021000_1_0090101_01_00

Exterior Lighting
(Sheet 1 of 5)
FIGURE-2-10-0-991-009-A01

****ON A/C A330-900**

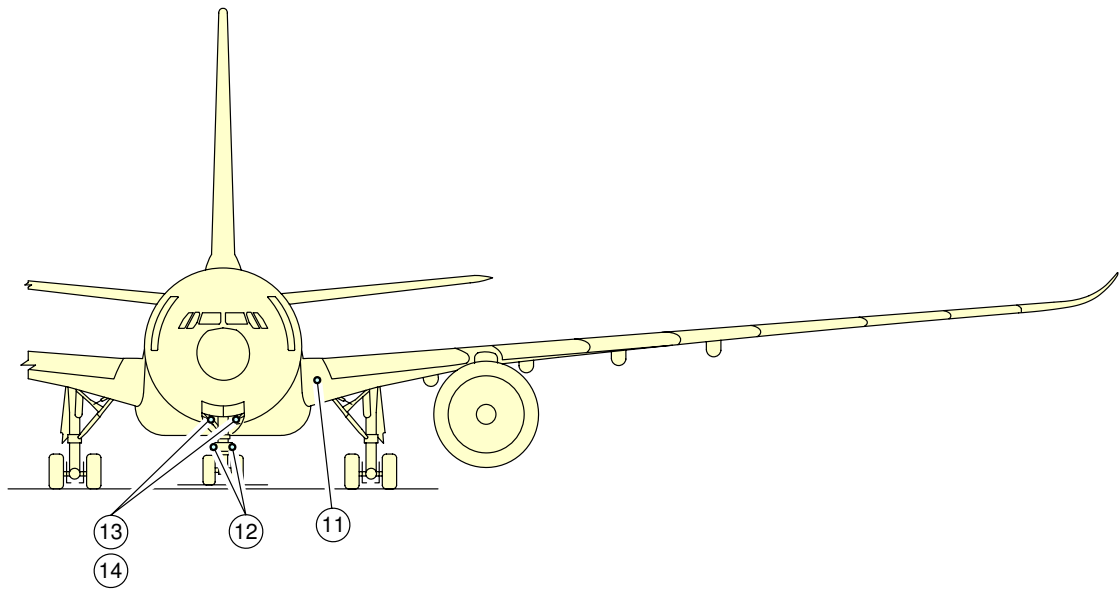

NOTE:

LIGHTS 13 AND 14 ARE THE SAME, BUT THEY OPERATE WITH DIFFERENT POWER SETTINGS.

F_AC_021000_1_0090102_01_00

Exterior Lighting
(Sheet 2 of 5)
FIGURE-2-10-0-991-009-A01

**ON A/C A330-900

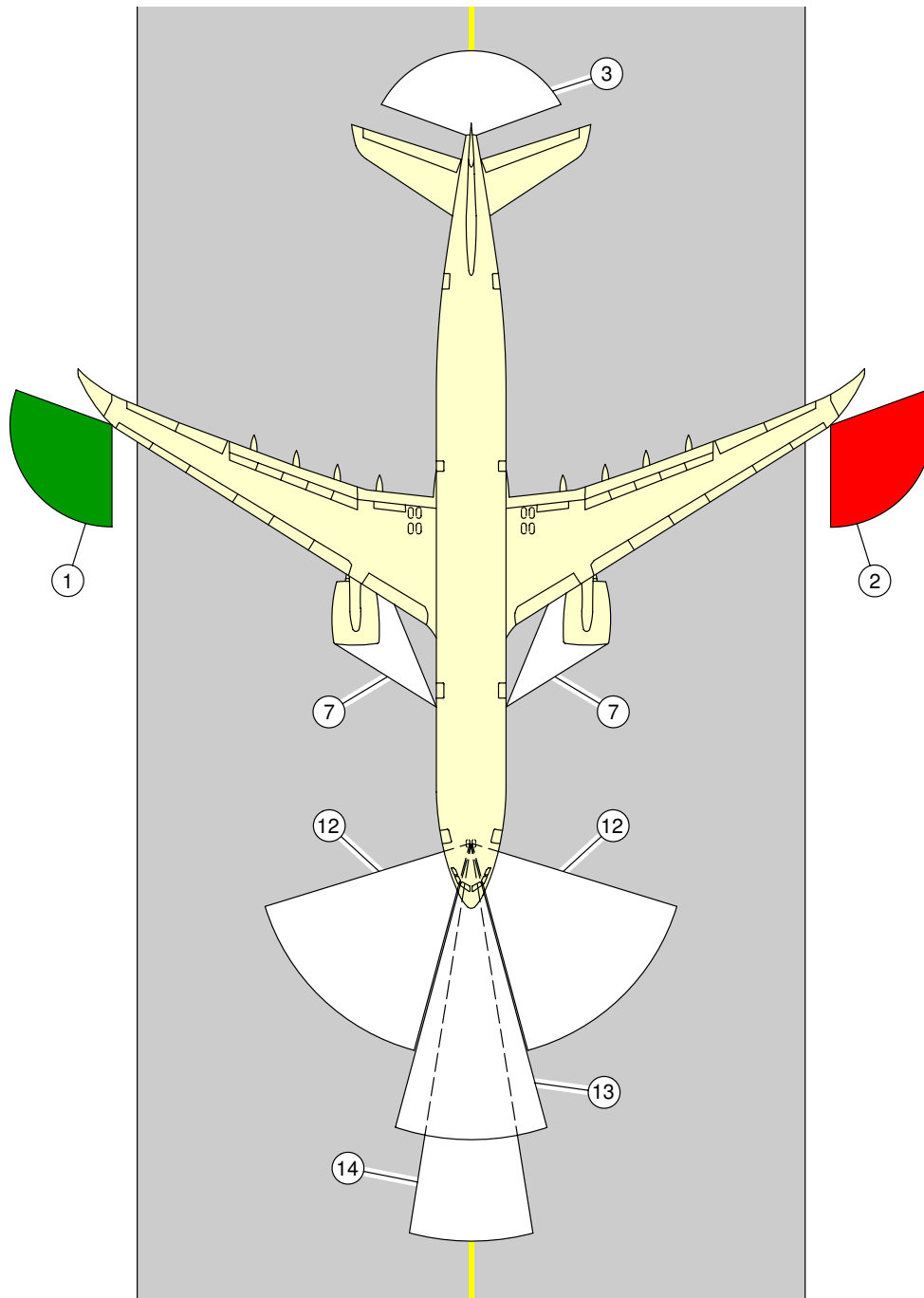

F_AC_021000_1_0090103_01_00

Exterior Lighting
(Sheet 3 of 5)
FIGURE-2-10-0-991-009-A01

**ON A/C A330-900

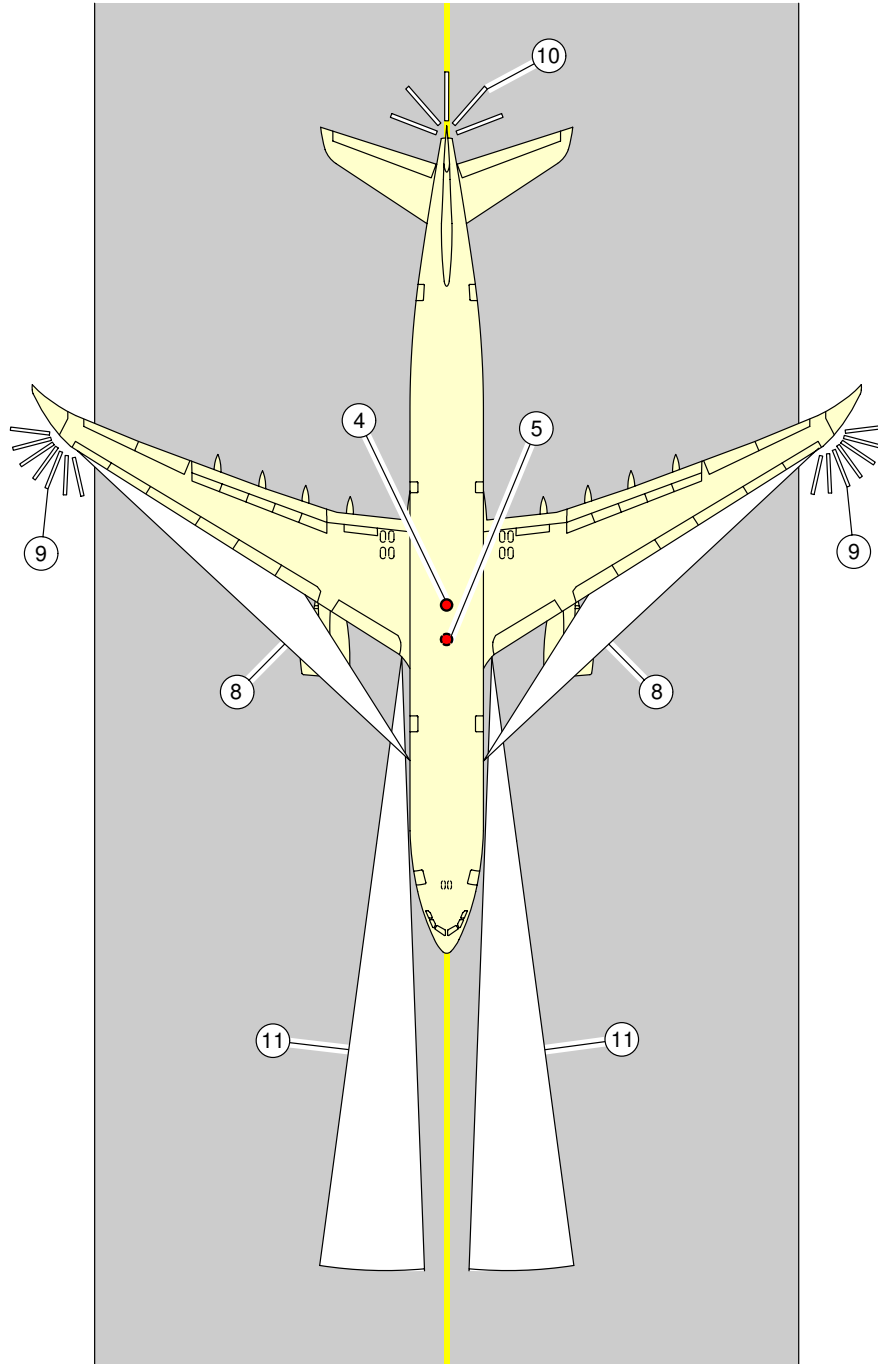

F_AC_021000_1_0090104_01_00

Exterior Lighting
(Sheet 4 of 5)
FIGURE-2-10-0-991-009-A01

**ON A/C A330-900

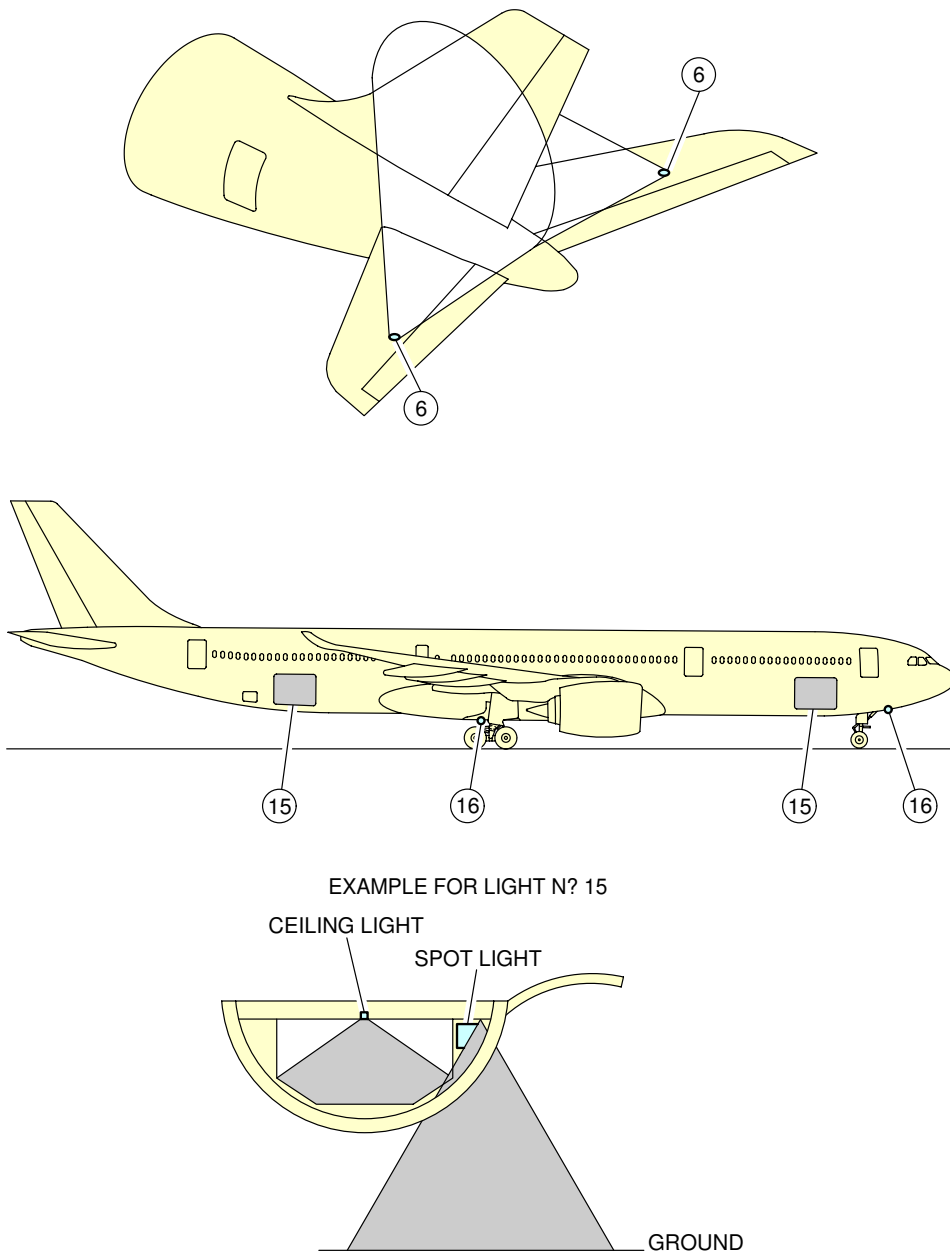

F_AC_021000_1_0090105_01_00

Exterior Lighting
(Sheet 5 of 5)
FIGURE-2-10-0-991-009-A01



2-11-0 **Antennas and Probes Location**

****ON A/C A330-200 A330-200F A330-300 A330-800 A330-900**

Antennas and Probes Location

1. This section gives the location of antennas and probes.

**ON A/C A330-200 A330-800

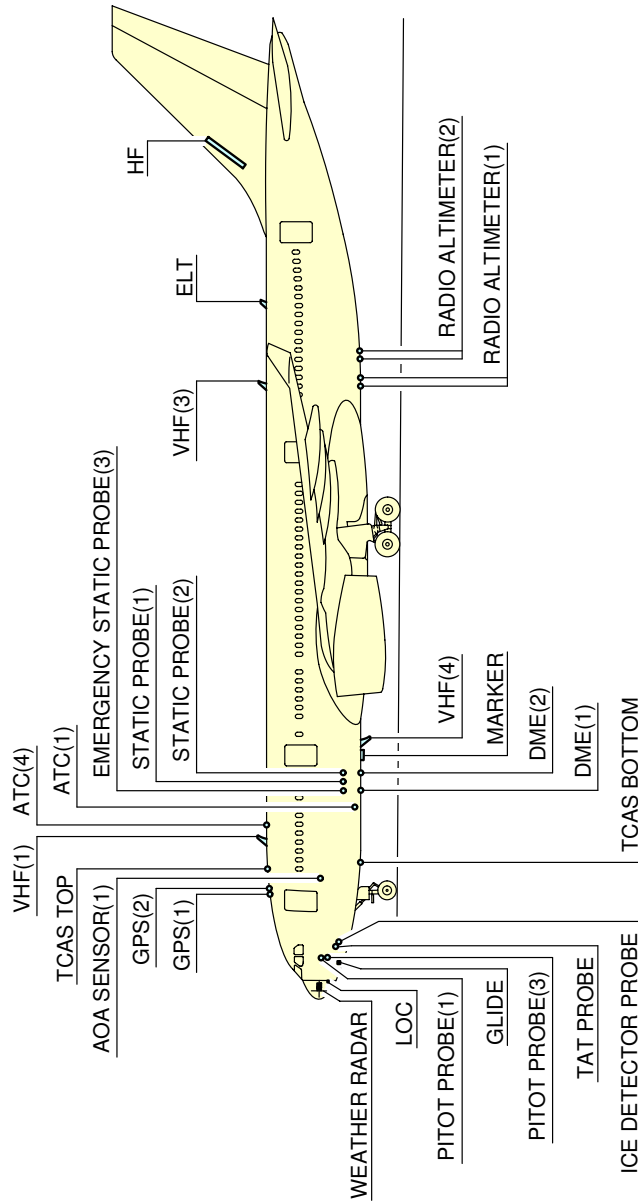

NOTE:
DEPENDENT ON AIRCRAFT CONFIGURATION

F_AC_021100_1_0010101_01_00

Antennas and Probes
Location (Sheet 1 of 2)
FIGURE-2-11-0-991-001-A01

**ON A/C A330-200 A330-800

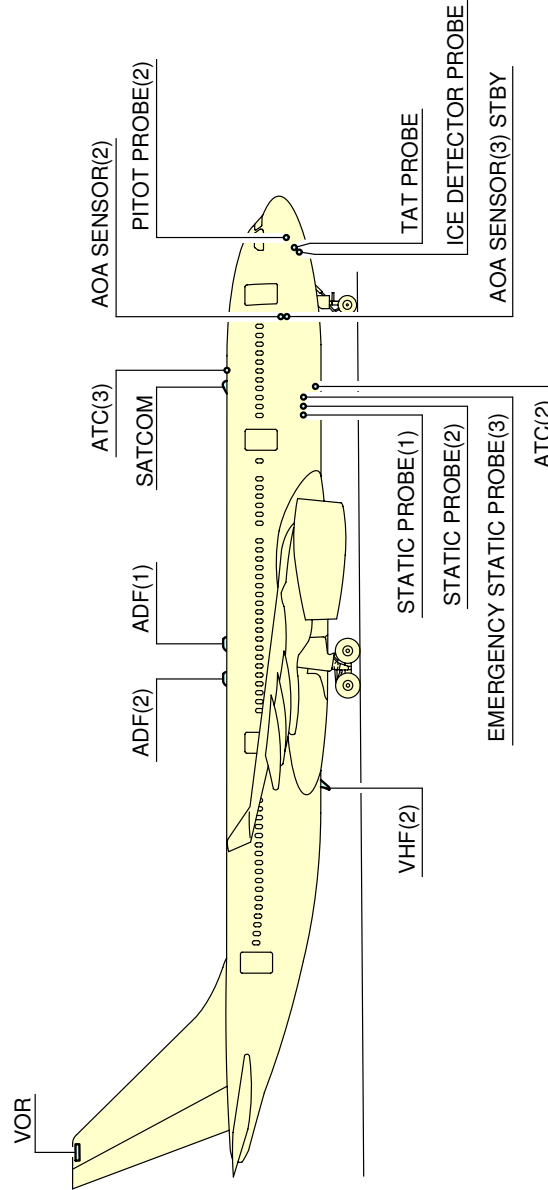

NOTE:
DEPENDENT ON AIRCRAFT CONFIGURATION

F_AC_021100_1_0010102_01_00

Antennas and Probes
Location (Sheet 2 of 2)
FIGURE-2-11-0-991-001-A01

****ON A/C A330-200F**

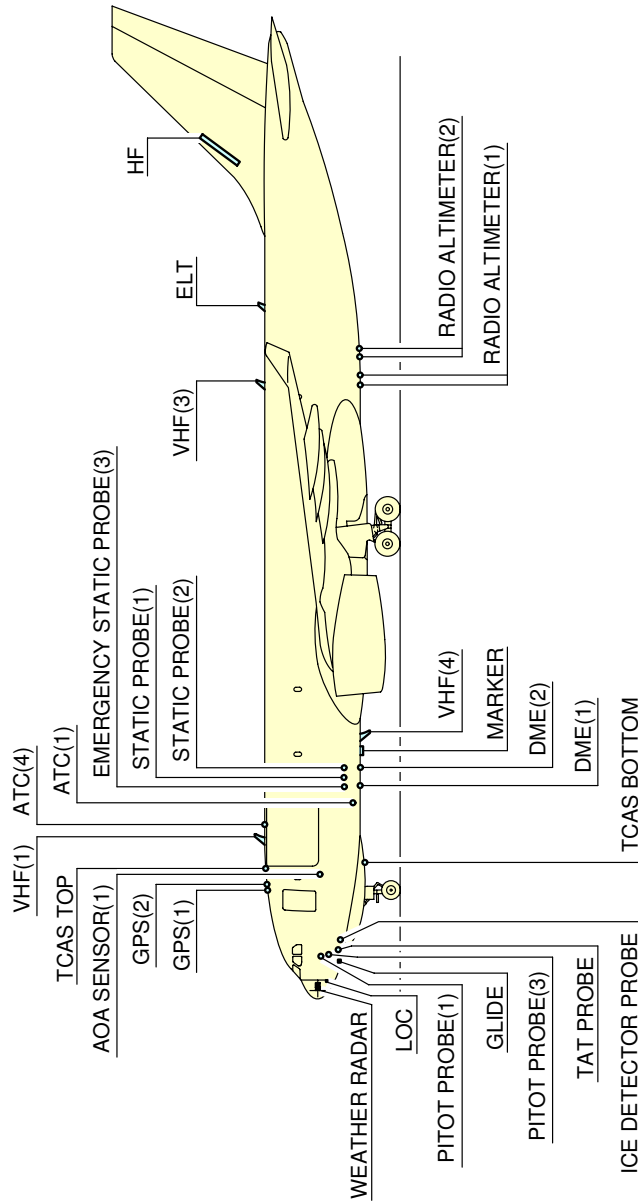

NOTE:
DEPENDENT ON AIRCRAFT CONFIGURATION

F_AC_021100_1_0020101_01_00

Antennas and Probes
Location (Sheet 1 of 2)
FIGURE-2-11-0-991-002-A01

**ON A/C A330-200F

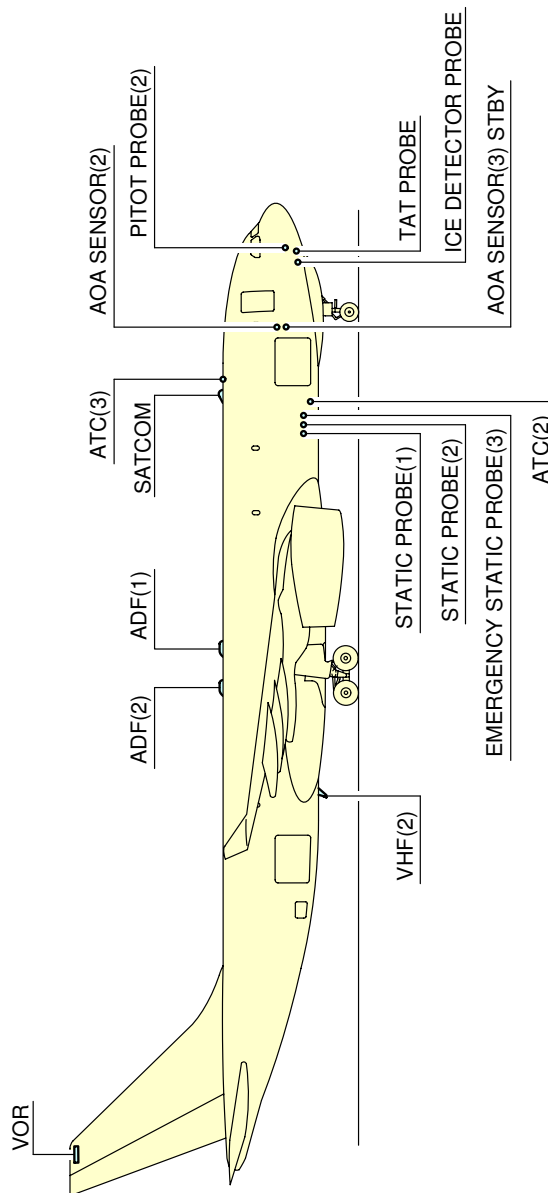

NOTE:
DEPENDENT ON AIRCRAFT CONFIGURATION

F_AC_021100_1_0020102_01_00

Antennas and Probes
Location (Sheet 2 of 2)
FIGURE-2-11-0-991-002-A01

**ON A/C A330-300 A330-900

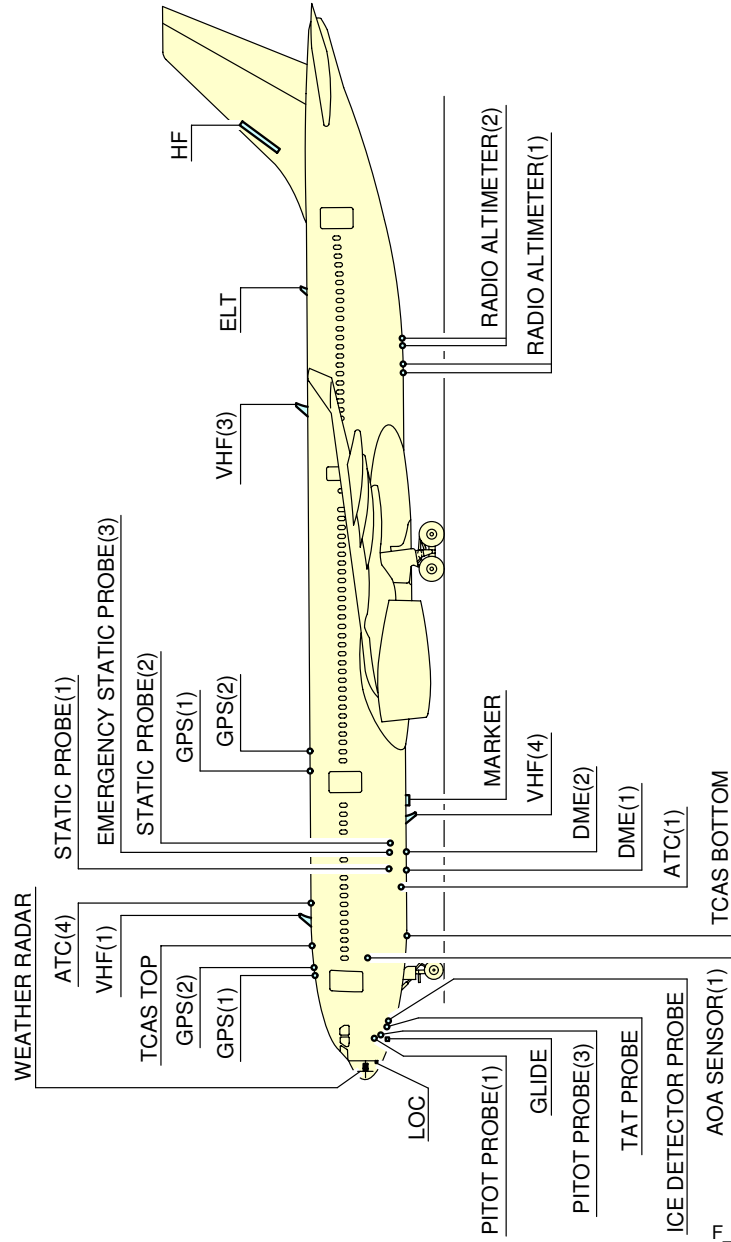

NOTE:
DEPENDENT ON AIRCRAFT CONFIGURATION

F_AC_021100_1_0030101_01_00

Antennas and Probes
Location (Sheet 1 of 2)
FIGURE-2-11-0-991-003-A01

**ON A/C A330-300 A330-900

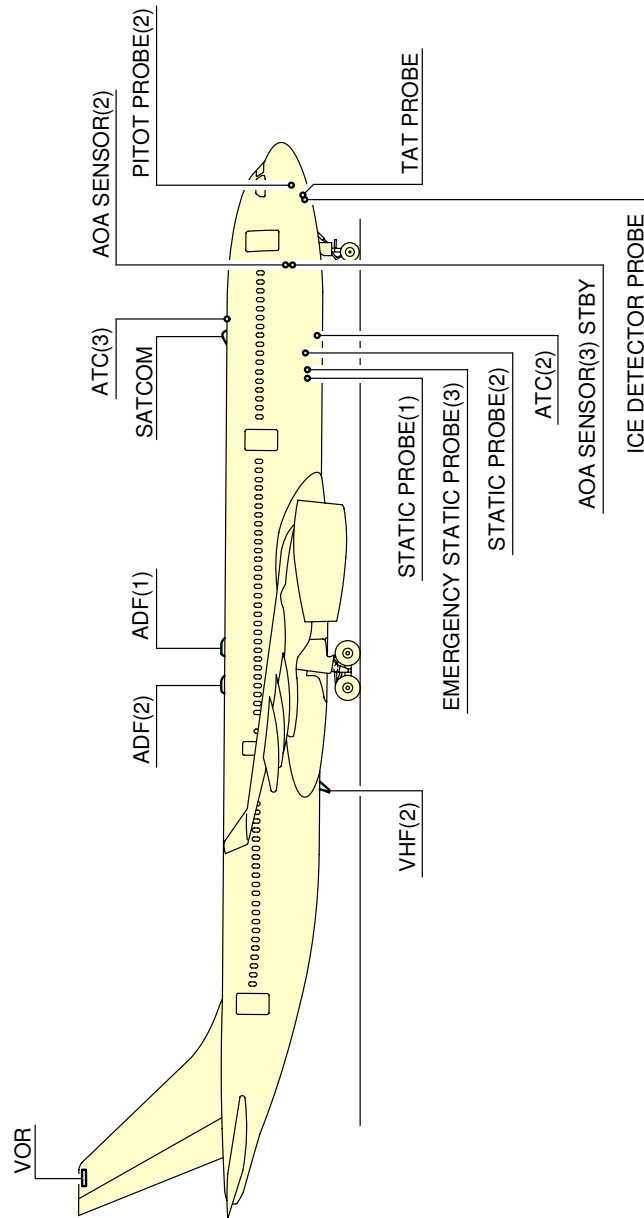

NOTE:
DEPENDENT ON AIRCRAFT CONFIGURATION

F_AC_021100_1_0030102_01_00

Antennas and Probes
Location (Sheet 2 of 2)
FIGURE-2-11-0-991-003-A01

2-12-0 Engine and Nacelle

****ON A/C A330-200 A330-200F A330-300 A330-800 A330-900**

Engine and Nacelle

****ON A/C A330-200 A330-200F A330-300**

1. Engine and Nacelle - PW 4000 Engine

A. Engine

The PW 4000 engine is a two spool, axial flow, high bypass ratio turbofan engine.

The engine has four major sections as follows:

- The compressor section
- The combustion section
- The turbine section
- The accessory drive section.

The compressor section has a six-stage low pressure compressor, a fan case, an intermediate case and an eleven-stage high pressure compressor. The 1st stage rotor in the low pressure compressor flows air through both the fan nozzle and the low compressor rotor/stator assemblies to the core of the engine. The high pressure compressor is used to increase the pressure of the primary airflow from the low compressor and send it to the diffuser.

The engine combustion section comprises the diffuser case and a combustion chamber installed in the case. The chamber forms the enclosure where fuel is mixed with air and burned to add energy to the primary gaspath.

The turbine section comprises the rear compressor drive turbine, the front compressor drive turbine and the Turbine Exhaust Case (TEC). The rear compressor drive turbine is the two-stage High Pressure Turbine (HPT) and the front compressor drive turbine is the five-stage Low Pressure Turbine (LPT). The HPT case assembly is air-cooled as part of the Turbine Case Cooling (TCC) system. The LPT rotor and stator assembly includes the front compressor driveshaft, the LPT case and the LPT spool case. The LPT case is externally cooled by turbine case cooling tubes.

The accessory drive section comprises the main gearbox and angle gearbox. The high pressure rotor is used to supply the main gearbox with power to drive the engine and aircraft-supplied accessories. Power comes from the towershaft in the intermediate case which is geared to the front of the high pressure rotor. The towershaft drives the angle gearbox bevel gear set which transmits power through the horizontal driveshaft assembly to the main gearbox group.

B. Nacelle

The nacelle is the aerodynamic structure around the basic engine. The nacelle provides a smooth airflow both around and into the engine to decrease drag and give better engine performance and prevents damage to the external surface of the engine and its accessories. The nacelle consists of the following major components:

- (1) Air Intake Cowl
The air intake cowl is an interchangeable aerodynamic fairing assembly that permits smooth airflow to the engine fan and core sections during ground and flight operation. The air intake cowl is attached with bolts to the engine fan case.
- (2) Fan Cowls
Fan cowls comprise a forward (fixed) fan cowl panel assembly and an aft fan cowl door assembly. The fan cowl panels and doors protect the engine and its components, and optimize the aerodynamic characteristics of the nacelle.
- (3) Thrust Reverser
The thrust reverser system is a component of the aircraft engine nacelle and is used to cancel the forward thrust and to give aerodynamic braking of the aircraft. The principle of the thrust reverser is to procedure forward flow of the fan exhaust by a hydraulically-actuated mechanical system. The system is designed to be used on the ground only.
- (4) Exhaust System
The turbine exhaust system has an exhaust nozzle and an exhaust plug. Both system components are acoustically treated and made to resist severe ambient conditions. The exhaust nozzle forms the outer contour of the engine primary exhaust annulus and the inner flow path of the fan airstream. The exhaust plug forms the inner contour of the engine primary exhaust annulus. The exhaust nozzle and exhaust plug are line replaceable units.

2. Engine and Nacelle - TRENT 700 Engine

A. Engine

The RB211-TRENT 700 engine is a high bypass ratio, triple spool turbofan.

The principal modules of the engine are:

- The Low Pressure Compressor (LPC) rotor
- The Intermediate Pressure (IP) compressor
- The intermediate case
- The HP system (this includes the High Pressure Compressor (HPC), the combustion system and the High Pressure Turbine (HPT))
- The Intermediate Pressure Turbine (IPT)
- The external gearbox
- The LPC case
- The Low Pressure Turbine (LPT).

The compressor system has three axial flow compressors in a triple spool configuration. The compressors are turned independently by their related turbines, each at its most satisfactory speed. The LP system has a single-stage compressor installed at the front of the engine. A shaft connects the compressor to a four-stage turbine at the rear of the gas generator. The gas generator also includes an eight-stage IP compressor, a six-stage HPC and a combustion system. Each of the compressors in the gas generator is connected to, and turned by, a different single-stage turbine. Between the HPC and the HPT is the annular combustion system which burns a mixture of fuel and air to supply energy as heat. Behind the LPT there is a common nozzle assembly which mixes the cold air and hot gas exhaust flows. The external gearbox module is installed below the rear case of the fan case. It has a gear train that decreases and increases the speed to meet the specified drive requirements of each accessory.

B. Nacelle

The nacelle gives the engine an aerodynamic shape. Each engine is housed in a nacelle suspended from a pylon attached below the wing. The nacelle consists of the following major components:

(1) Air Intake Cowl

The air intake cowl is attached to the forward flange of the front LPC case. Its function is to supply inlet air in a satisfactory condition for the engine compressors.

(2) Fan Cowl Doors

The fan cowl doors hang on the aircraft wing pylon and are closed around the LPC cases. They can be opened during ground maintenance to give access to the components installed on the cases and to let the thrust reverser cowl doors be opened.

(3) Thrust Reverser

The thrust reverser is a component of the aircraft engine nacelle. The thrust reverser is a twin thrust reverser cowl door ('C' duct) construction providing a fan duct inner wall fairing for the core engine between the top and bottom bifurcation walls. The thrust reverser incorporates hydraulically-powered actuators to operate four pivoting doors which redirect the fan air flow in reverse thrust. Hydraulic power is provided from the aircraft hydraulic system to position the doors in a "stowed" position for forward thrust and "deployed" position for reverse thrust.

(4) Common Nozzle Assembly (CNA)

The CNA is attached to the aft flange of the exhaust case. The function of the CNA is to mix the core engine exhaust with the LPC outlet air.

**ON A/C A330-200 A330-300

3. Engine and Nacelle - GE CF6-80E1 Engine

A. Engine

The CF6-80E1 engine is a high bypass ratio, dual-rotor, axial-flow turbofan engine. The major modules of the engine are:

- The fan module
- The core module

- The High Pressure Turbine (HPT)
- The Low Pressure Turbine (LPT)
- The accessory drive modules.

The fan module supplies approximately 80 percent of the total engine thrust through secondary air flow acceleration. The fan module also boosts primary air flow to the high pressure compressor. The fan rotor and booster assembly is part of the fan module. Air, taken in through the fan section, passes through successive stages of compressor rotor blades and compressor stator vanes, being compressed as it passes from stage to stage. The inlet guide vanes and the first five-stages of the stator are variable, and change their angular position as a function of the compressor inlet temperature and corrected engine speed. The combustion of fuel takes place in the combustor installed in the compressor rear frame. The two main modules of the turbine are the HPT and the LPT. The function of the HPT is to drive the high pressure compressor by converting the combustor exhaust gas flow into mechanical force. The LPT subsequently also converts this flow into force to drive the fan and booster assemblies. The HPT rotor is a two-stage air-cooled turbine. The LPT rotor drives the fan and booster rotors through the LPT rotor shaft by extracting energy from the combustion gases leaving the HPT. Power for both engine and aircraft accessories is extracted through a system of gearboxes and shafts. The accessory gearbox assembly is mounted on the compressor casing. The gearbox receives torque from the horizontal drive shaft and distributes the torque through spur gears to drive the gearbox-mounted accessories.

B. Nacelle

The nacelle provides protection for the engine and the engine accessories, and aerodynamic airflow around the engine during operation. Each engine is mounted in a nacelle suspended from a pylon attached to the wing lower surface. The nacelle consists of the following major components:

(1) Air Intake Cowl Assembly

The air intake cowl structure is an interchangeable aerodynamically-faired assembly which supplies the inlet airflow to the fan and core sections of the engine. It is installed on the forward face of the engine fan case.

(2) Fan Cowl Doors

The fan cowl door assemblies are engine-to-engine interchangeable units enclosing the engine fan case between the air intake cowl and thrust reverser cowl doors. Each assembly is supported by three hinges at the pylon and latched along the bottom splitline with three tension hook latches.

(3) Thrust Reverser

The thrust reverser is a bifurcated assembly of two halves forming the fan exhaust duct and nozzle, enclosing the engine between the fan frame and the core cowling, and containing the mechanism for reversing the fan exhaust flow during aircraft landing.

(4) Core Cowl Doors

The core cowl door assemblies are interchangeable units which enclose the core engine between the thrust reverser cowl doors and the exhaust nozzle. Each assembly is hinged from the pylon in three locations and latched along the bottom splitline with three tension hook latches.

(5) Exhaust Nozzle

The exhaust nozzle, through which all exhaust gases are expelled, is part of the aerodynamically-structured nacelle. The exhaust nozzle provides a fixed area annulus for exhausting the core engine gas stream flow and provides a continuation of the aerodynamic cowling from the core cowl interface.

****ON A/C A330-800 A330-900**

4. Engine and Nacelle - TRENT 7000 Engine

A. Engine

The TRENT 7000 engine is a high by-pass ratio, triple spool turbo fan. It has a Low Pressure (LP) system and a gas generator system.

The major modules of the engines are:

- The air Inlet section
- The compressor section
- The combustion section
- The turbine section
- The accessory drives

The air Inlet section:- The function of the air inlet section is to make sure there is a smooth flow of air into the LP compressor.

The compressor section:- The function of the compressor section is to increase the pressure of the air. The compressor section has a LP and Intermediate Pressure (IP) compressor. Each section is connected to the applicable turbine by a shaft.

The Combustion section:- The function of the combustion section is to burn a mixture of fuel and air to supply energy as heat. The heat is released into the system to increase the speed of the air and give a smooth expanded gas flow to the turbine section. The combustion section includes the High Pressure (HP) compressor and HP turbine.

The turbine section:- The function of the turbine section is to use the energy in the airflow to turn the compressors. The turbine section has a LP and IP turbine. Each section is connected to the applicable compressor by a shaft.

The accessory drives:- The function of the accessory drives section is to transmit mechanical energy from the IP rotor to the accessory units installed on the external gearbox.

B. Nacelle

The nacelle gives the engine an aerodynamic shape. Each engine is housed in a nacelle suspended from a pylon attached below the wing. The nacelle consists of the following major components:

- (1) **Air Intake Cowl**
The air intake cowl is attached to the forward flange of the front Low Pressure Compressor (LPC) case. Its function is to supply inlet air in a satisfactory condition for the engine compressors.
- (2) **Fan Cowl Doors**
The fan cowl doors hang on the aircraft wing pylon and are closed around the engine fan case. They can be opened during ground maintenance to give access to the components installed on the cases and to let the thrust reverser cowl doors be opened.
- (3) **Thrust Reverser**
The thrust reverser is a component of the aircraft engine nacelle. The thrust reverser is a twin thrust reverser cowl door ('C' duct) construction providing a fan duct inner wall fairing for the core engine between the top and bottom bifurcation walls. The thrust reverser incorporates hydraulically-powered actuators to operate translating doors and blocker doors which redirect the fan air flow in reverse thrust thanks to cascades. Hydraulic power is provided from the aircraft hydraulic system to position the translating doors in a "stowed" position for forward thrust and "deployed" position for reverse thrust.
- (4) **Exhaust**
The exhaust system provides flow contour for exhaust gas and has been designed to be able to withstand hot environment due to nearness of the exhaust gas. It is composed of two parts, the primary nozzle and the exhaust plug. The exhaust system is a plain short structure, attached to engine turbine exhaust case.

**ON A/C A330-200 A330-200F A330-300

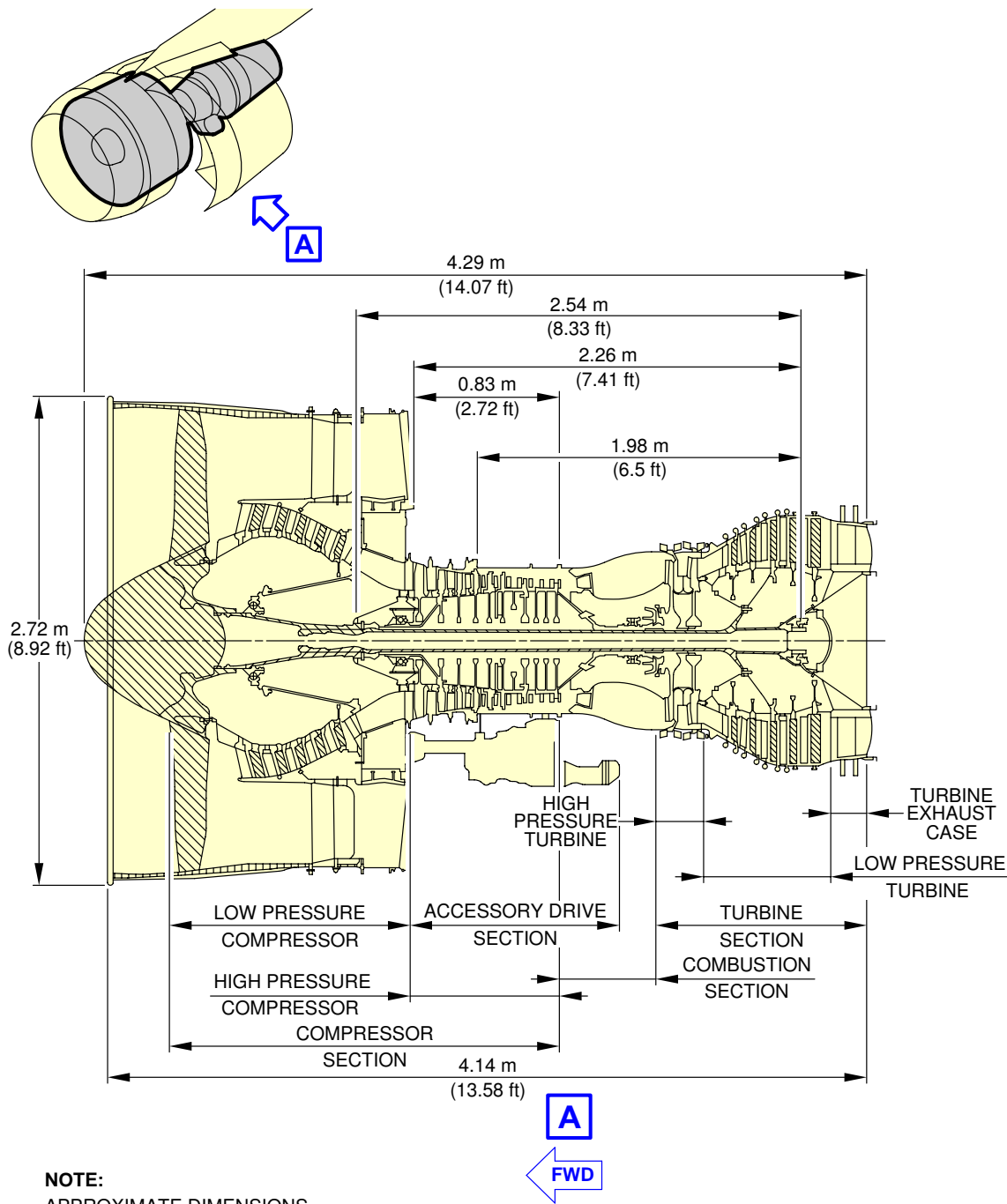

F_AC_021200_1_0010101_01_00

Engine and Nacelle
 Engine Dimensions - PW 4000
 FIGURE-2-12-0-991-001-A01

****ON A/C A330-200 A330-200F A330-300**

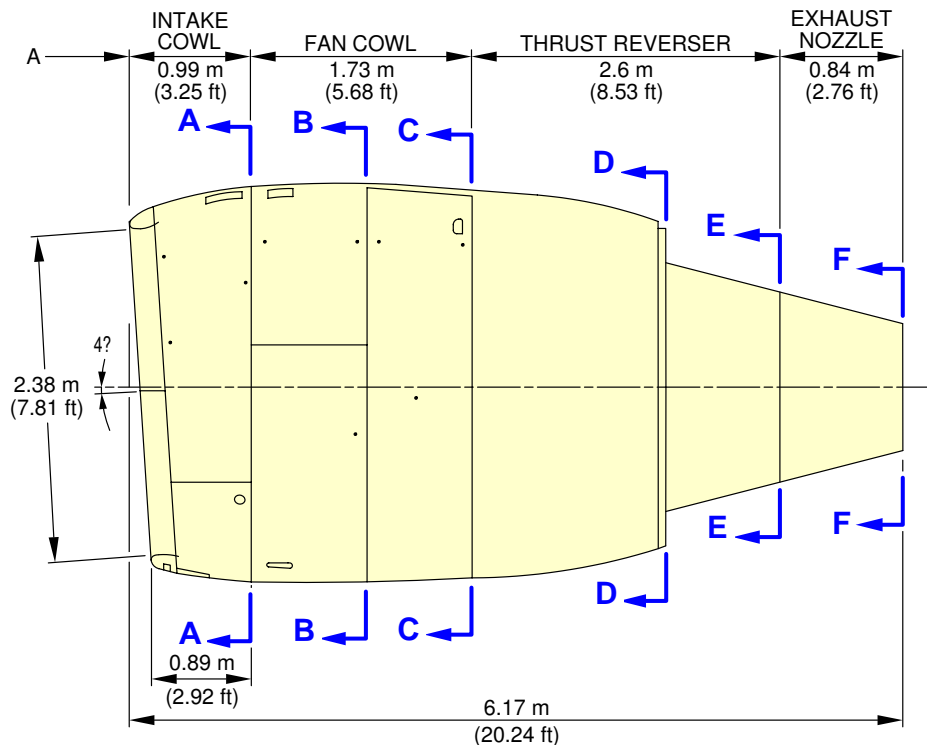

DISTANCE FROM NOSE	A330-300	A330-200/ A330-200F
A	21.45 m (70.37 ft)	18.25 m (59.88 ft)

	W	U	V	NAC STA
A-A	3.12 m (10.24 ft)	1.56 m (5.12 ft)	1.56 m (5.12 ft)	0.89 m (2.92 ft)
B-B	3.16 m (10.37 ft)	1.58 m (5.18 ft)	1.58 m (5.18 ft)	1.79 m (5.87 ft)
C-C	3.06 m (10.04 ft)	1.53 m (5.02 ft)	1.53 m (5.02 ft)	2.62 m (8.6 ft)
D-D	2.58 m (8.46 ft)	1.29 m (4.23 ft)	1.29 m (4.23 ft)	4.62 m (15.16 ft) *
E-E	1.42 m (4.66 ft)	0.71 m (2.33 ft)	0.71 m (2.33 ft)	5.23 m (17.16 ft)
F-F	1 m (3.28 ft)	0.5 m (1.64 ft)	0.5 m (1.64 ft)	6.07 m (19.91 ft)

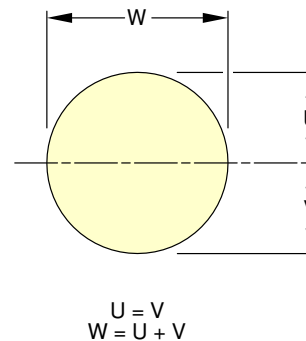

NOTE:
APPROXIMATE DIMENSIONS.

* STOWED POSITION

F_AC_021200_1_0020101_01_00

Engine and Nacelle
Nacelle Dimensions - PW 4000
FIGURE-2-12-0-991-002-A01

**ON A/C A330-200 A330-200F A330-300

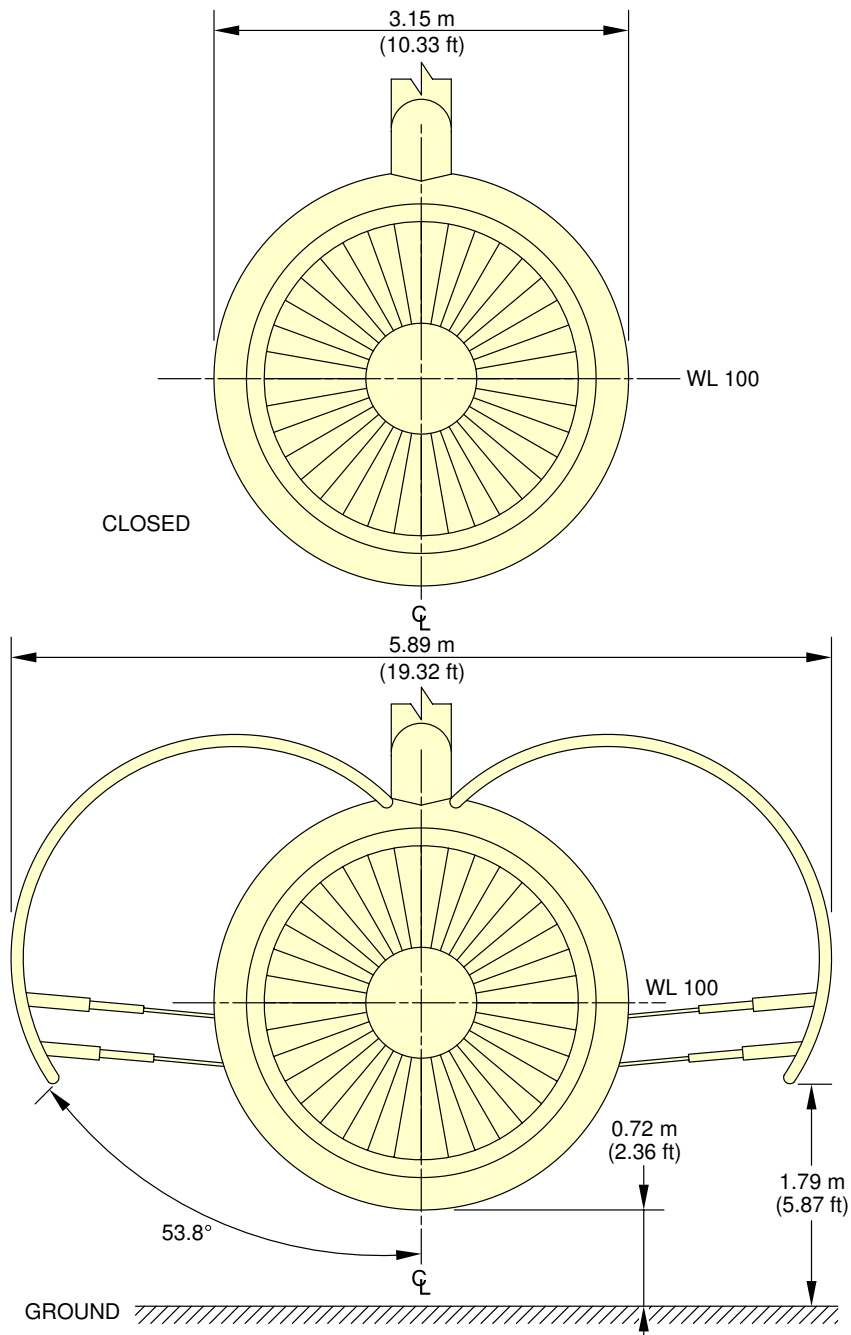

NOTE:
APPROXIMATE DIMENSIONS.

F_AC_021200_1_0030101_01_01

Engine and Nacelle
Fan Cowls - PW 4000
FIGURE-2-12-0-991-003-A01

****ON A/C A330-200 A330-200F A330-300**

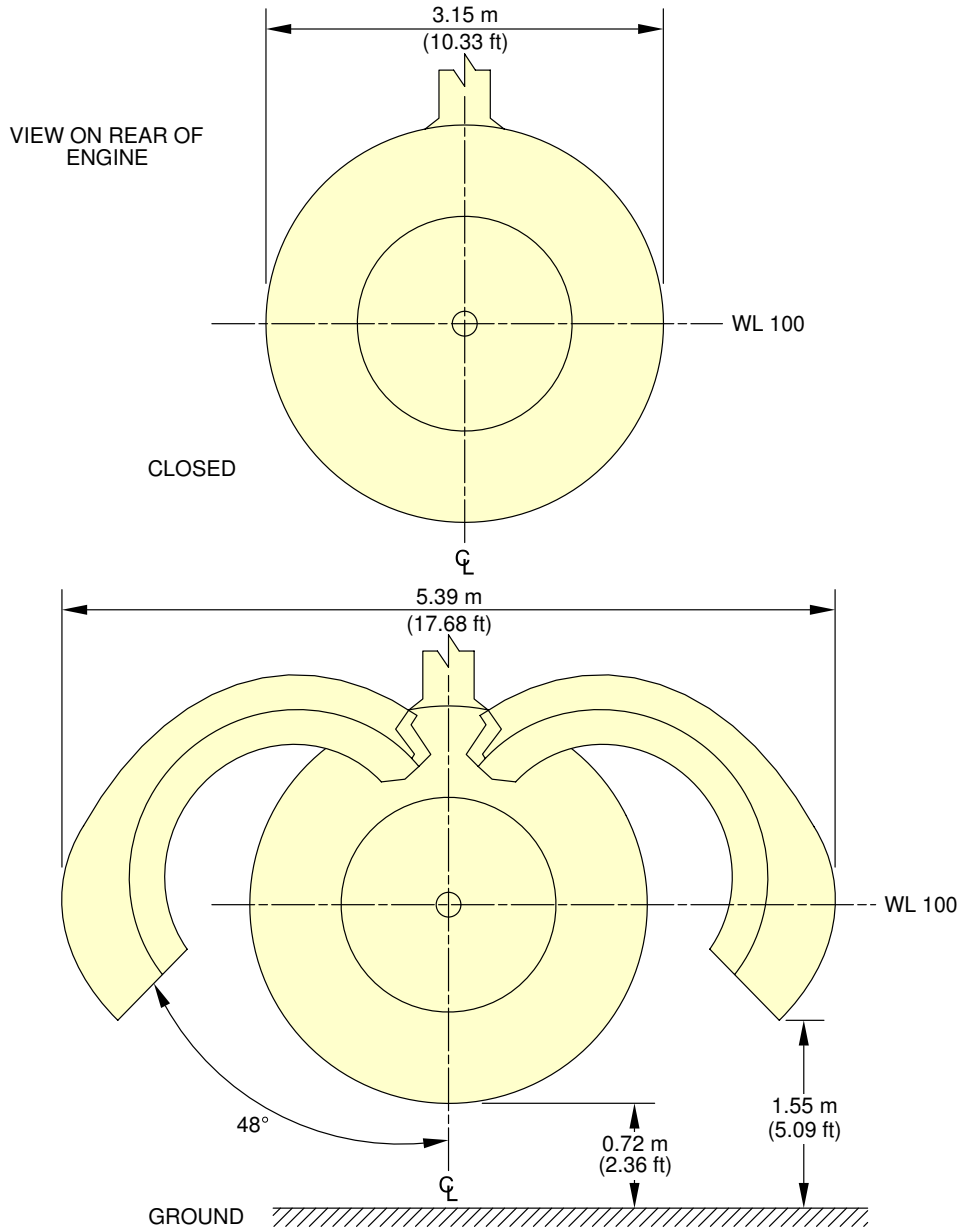

CAUTION:
DO NOT ACTUATE SLATS WITH THRUST REVERSER COWLS AT 48° OPEN POSITION.

NOTE:
APPROXIMATE DIMENSIONS.

F_AC_021200_1_0040101_01_01

Engine and Nacelle
Thrust Reverser Cowls - PW 4000
FIGURE-2-12-0-991-004-A01

**ON A/C A330-200 A330-200F A330-300

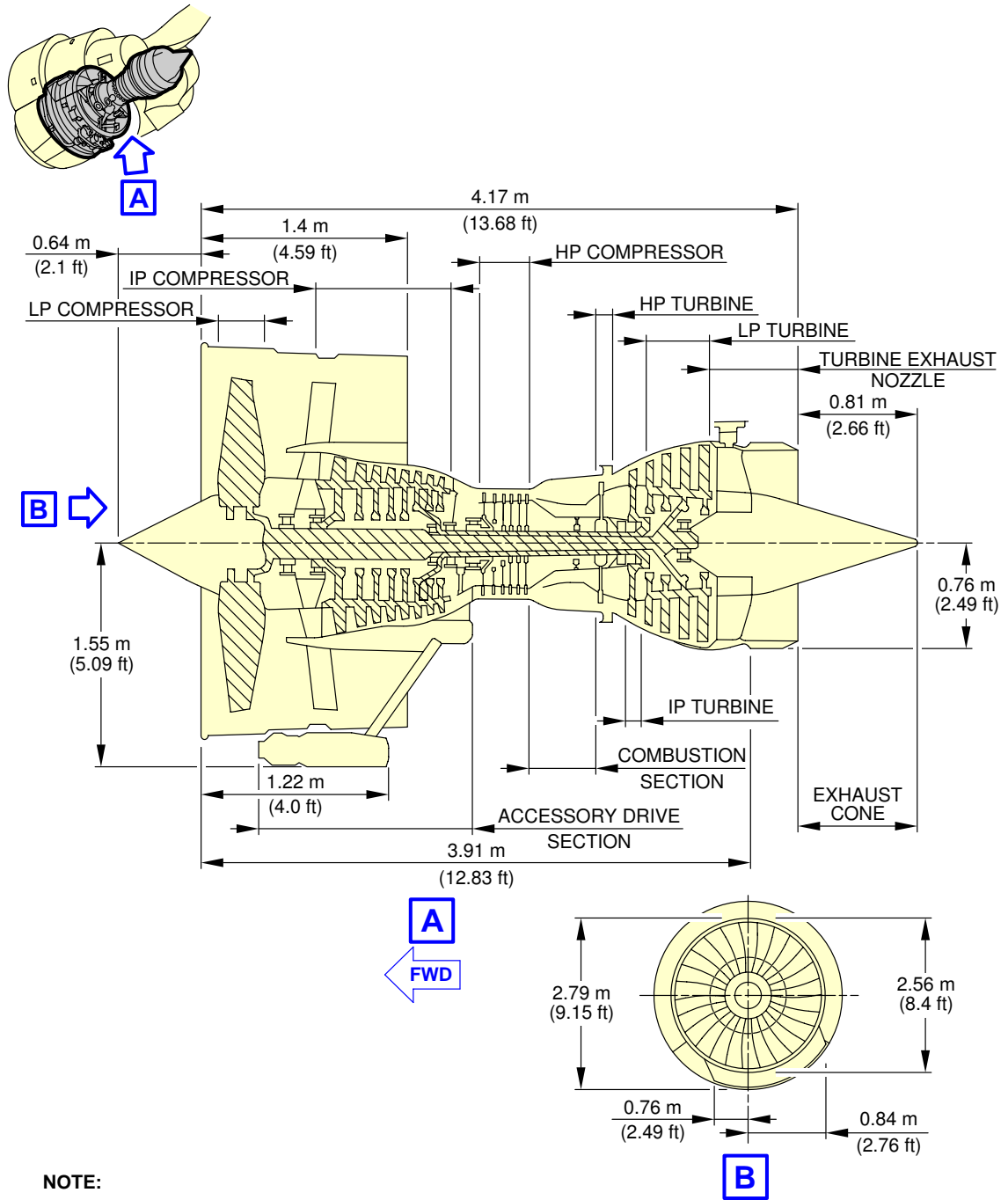

NOTE:
APPROXIMATE DIMENSIONS.

F_AC_021200_1_0050101_01_00

Engine and Nacelle
Engine Dimensions - TRENT 700
FIGURE-2-12-0-991-005-A01

****ON A/C A330-200 A330-200F A330-300**

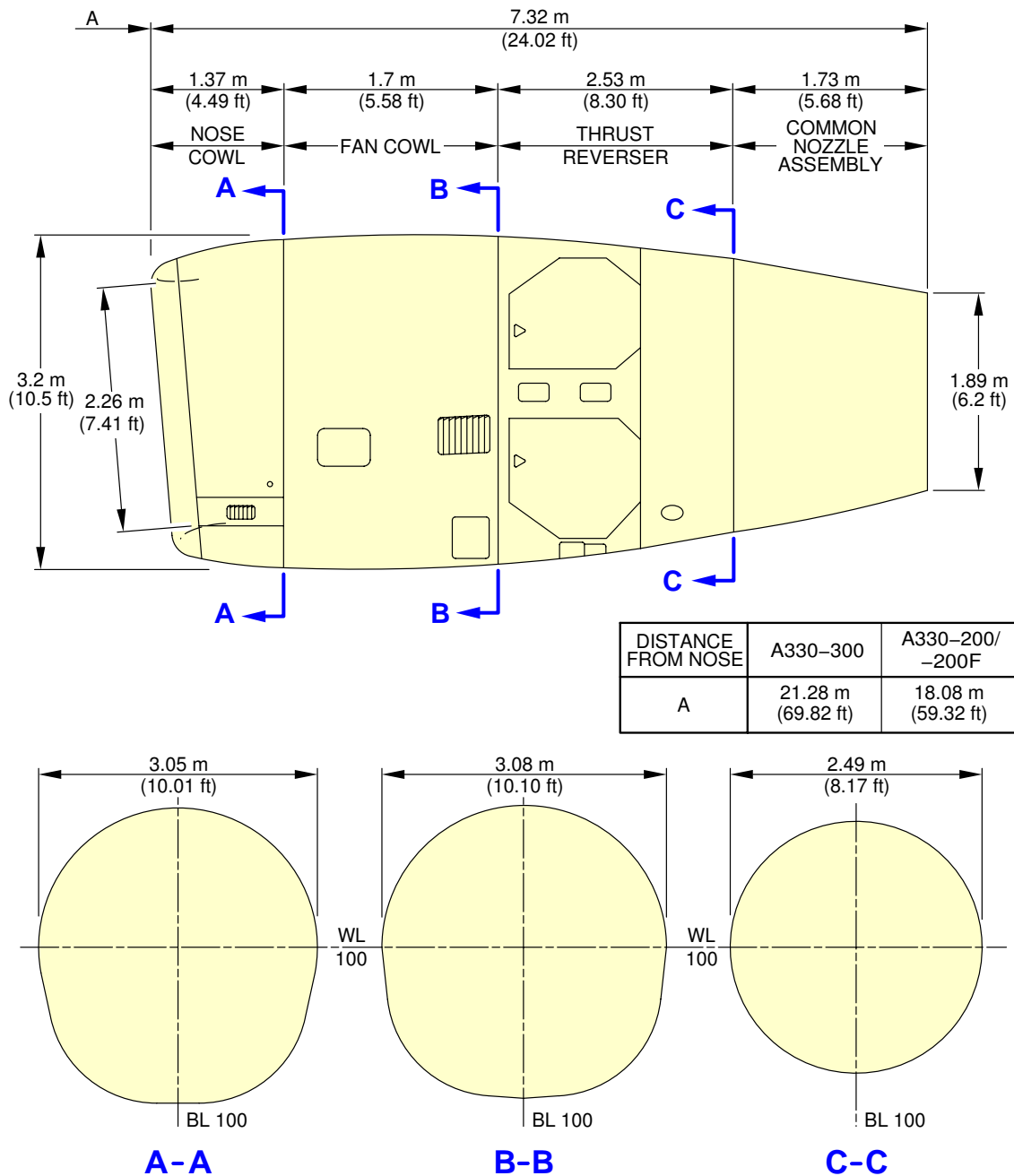

NOTE:
APPROXIMATE DIMENSIONS.

F_AC_021200_1_0060101_01_00

Engine and Nacelle
Nacelle Dimensions - TRENT 700
FIGURE-2-12-0-991-006-A01

****ON A/C A330-200 A330-200F A330-300**

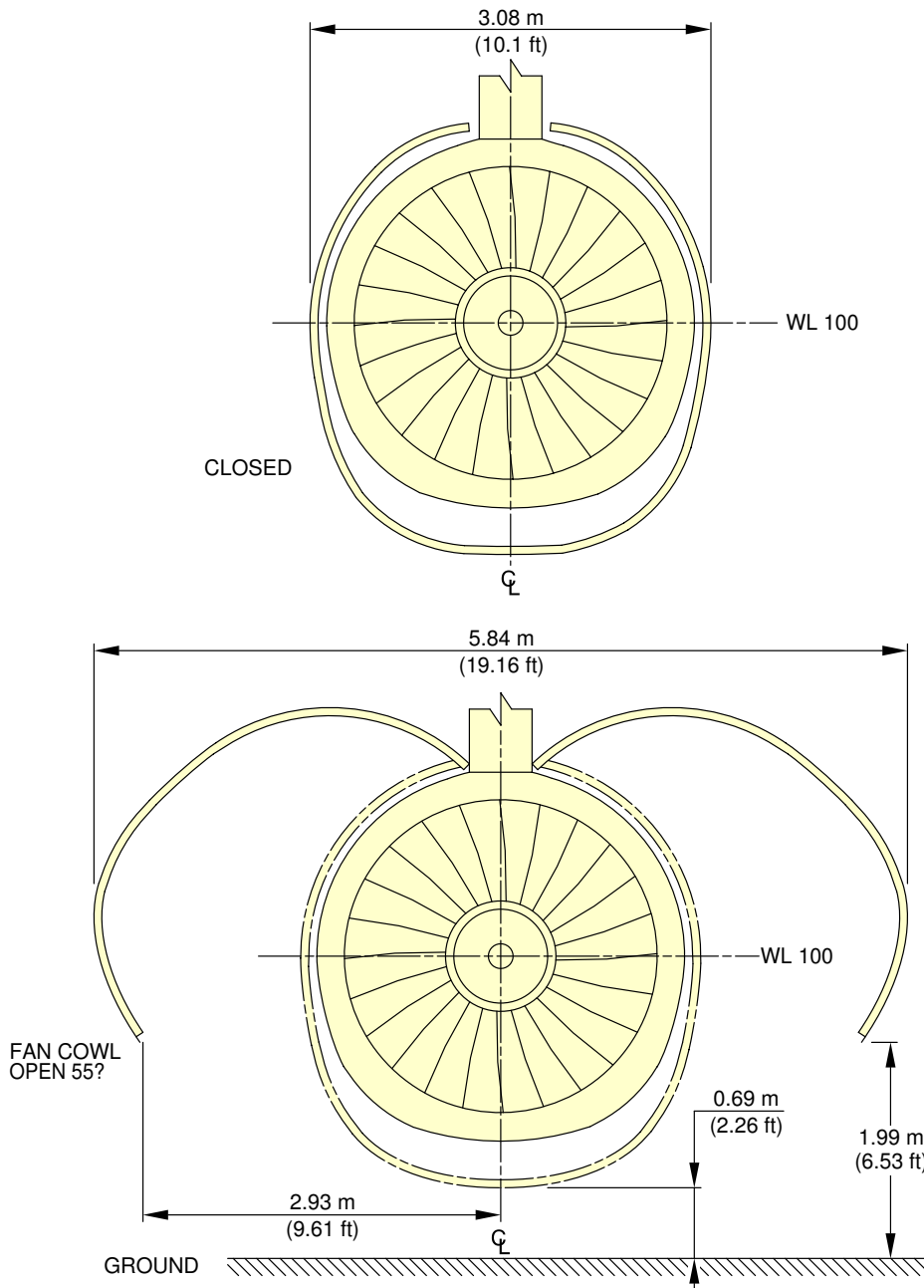

NOTE:
APPROXIMATE DIMENSIONS.

F_AC_021200_1_0070101_01_00

Engine and Nacelle
Fan Cowls - TRENT 700
FIGURE-2-12-0-991-007-A01

****ON A/C A330-200 A330-200F A330-300**

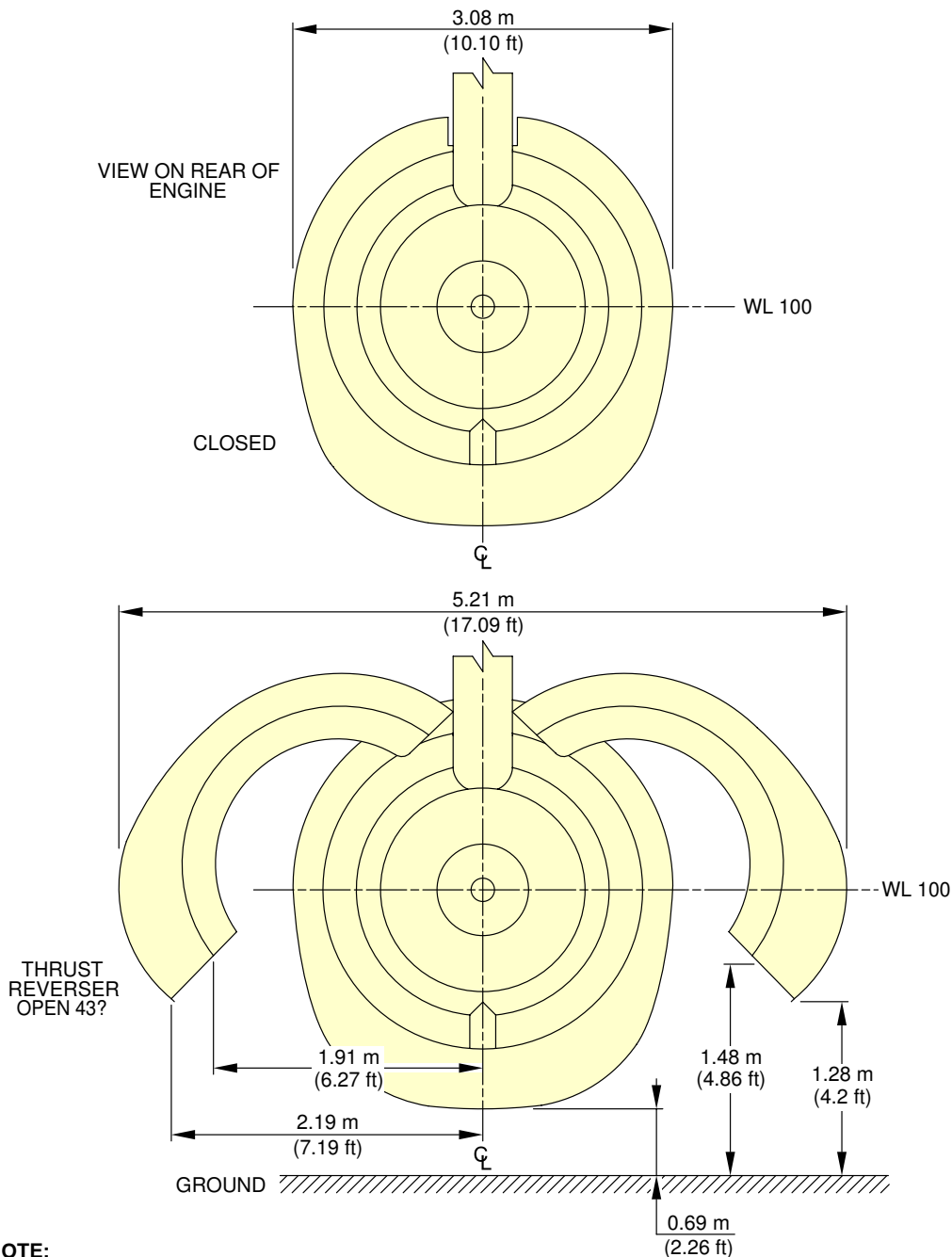

NOTE:
APPROXIMATE DIMENSIONS.

F_AC_021200_1_0080101_01_00

Engine and Nacelle
Thrust Reverser Cowls - TRENT 700
FIGURE-2-12-0-991-008-A01

**ON A/C A330-200 A330-300

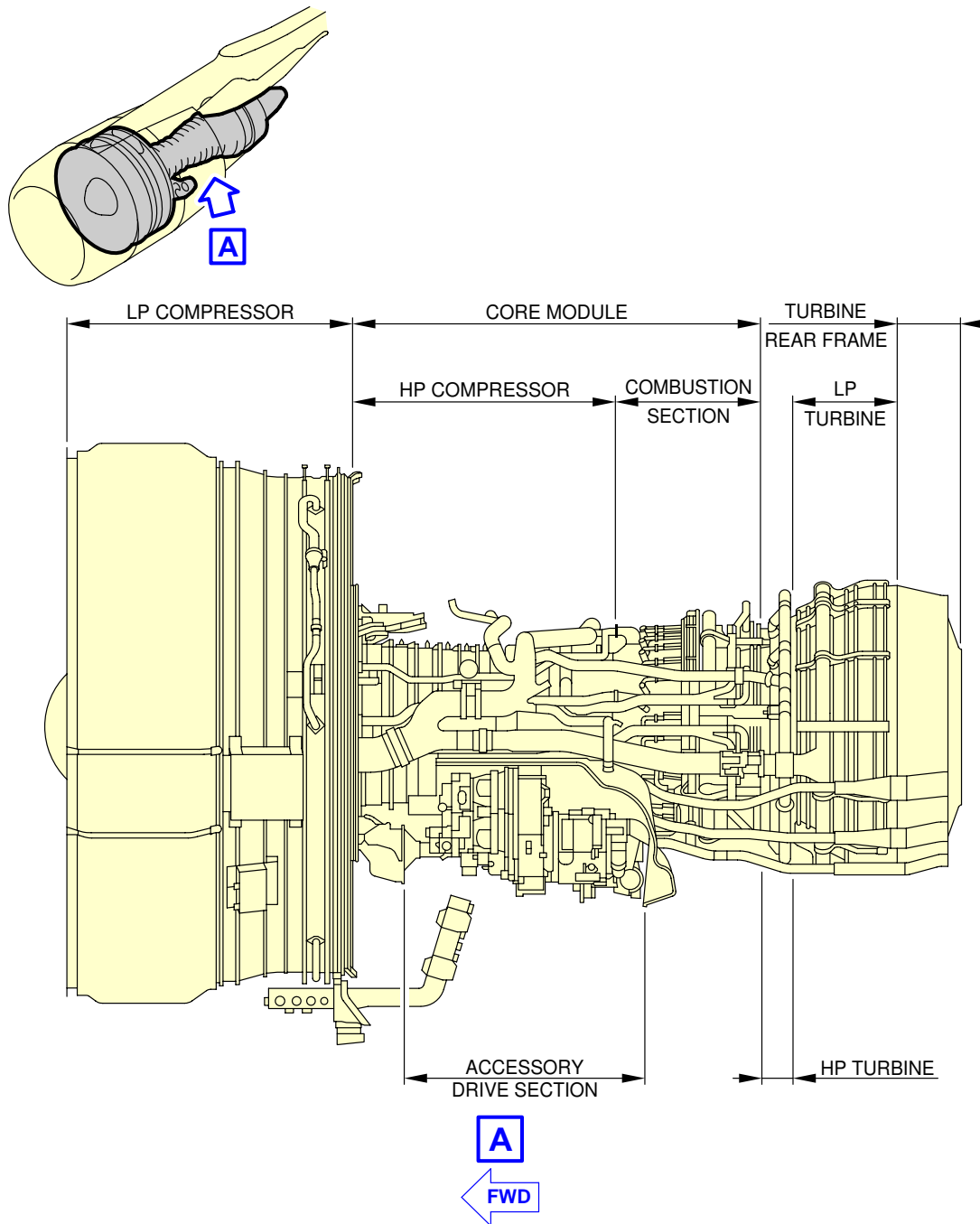

F_AC_021200_1_0090101_01_00

Engine and Nacelle
Engine Dimensions - GE CF6-80E1
FIGURE-2-12-0-991-009-A01

****ON A/C A330-200 A330-300**

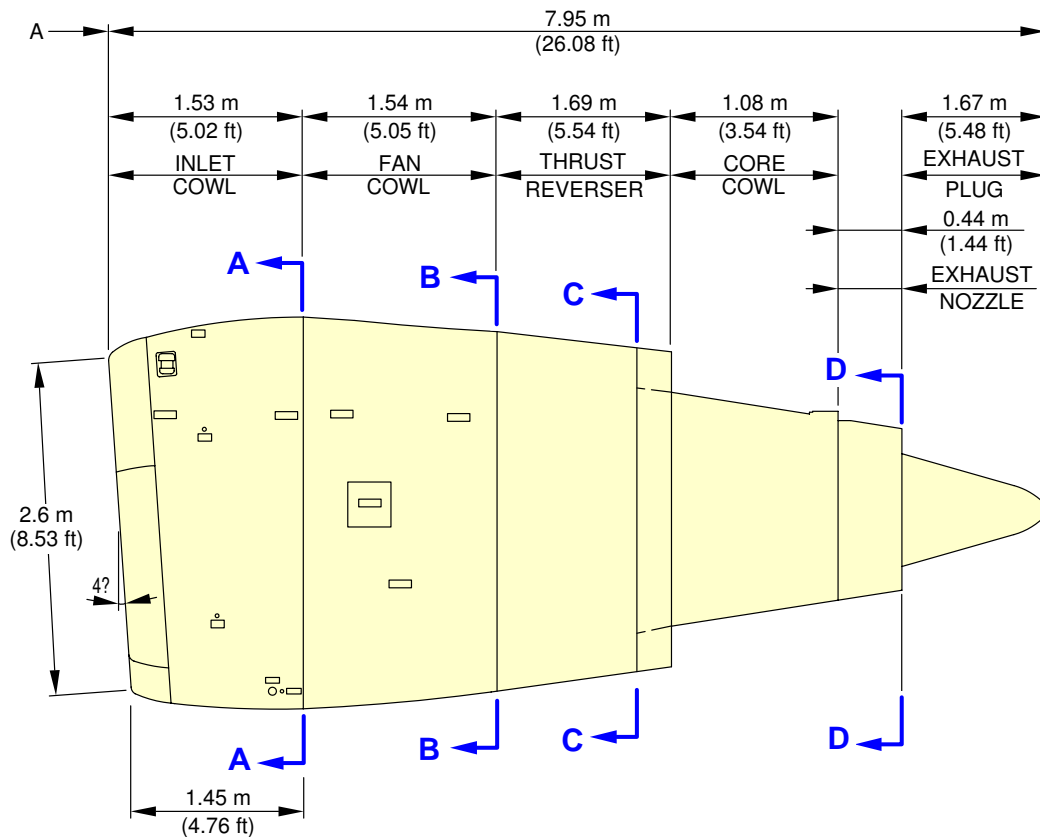

DISTANCE FROM THE NOSE	A330-300	A330-200
A	21.14 m (69.36 ft)	17.94 m (58.86 ft)

	W	U	V	NAC STA
A-A	3.08 m (10.1 ft)	1.51 m (4.95 ft)	1.59 m (5.22 ft)	3.49 m (11.45 ft)
B-B	2.82 m (9.25 ft)	1.41 m (4.63 ft)	1.41 m (4.63 ft)	5.03 m (16.5 ft)
C-C	2.49 m (8.17 ft)	1.25 m (4.1 ft)	1.25 m (4.1 ft)	6.4 m (21 ft)
D-D	1.28 m (4.2 ft)	0.64 m (2.1 ft)	0.64 m (2.1 ft)	8.24 m (27.03 ft)

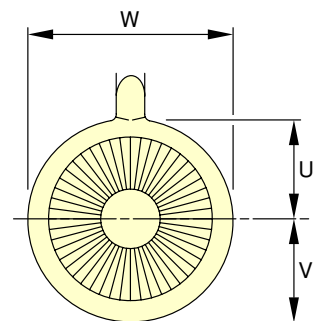

NOTE:
APPROXIMATE DIMENSIONS

F_AC_021200_1_0100101_01_00

Engine and Nacelle
Nacelle Dimensions - GE CF6-80E1
FIGURE-2-12-0-991-010-A01

**ON A/C A330-200 A330-300

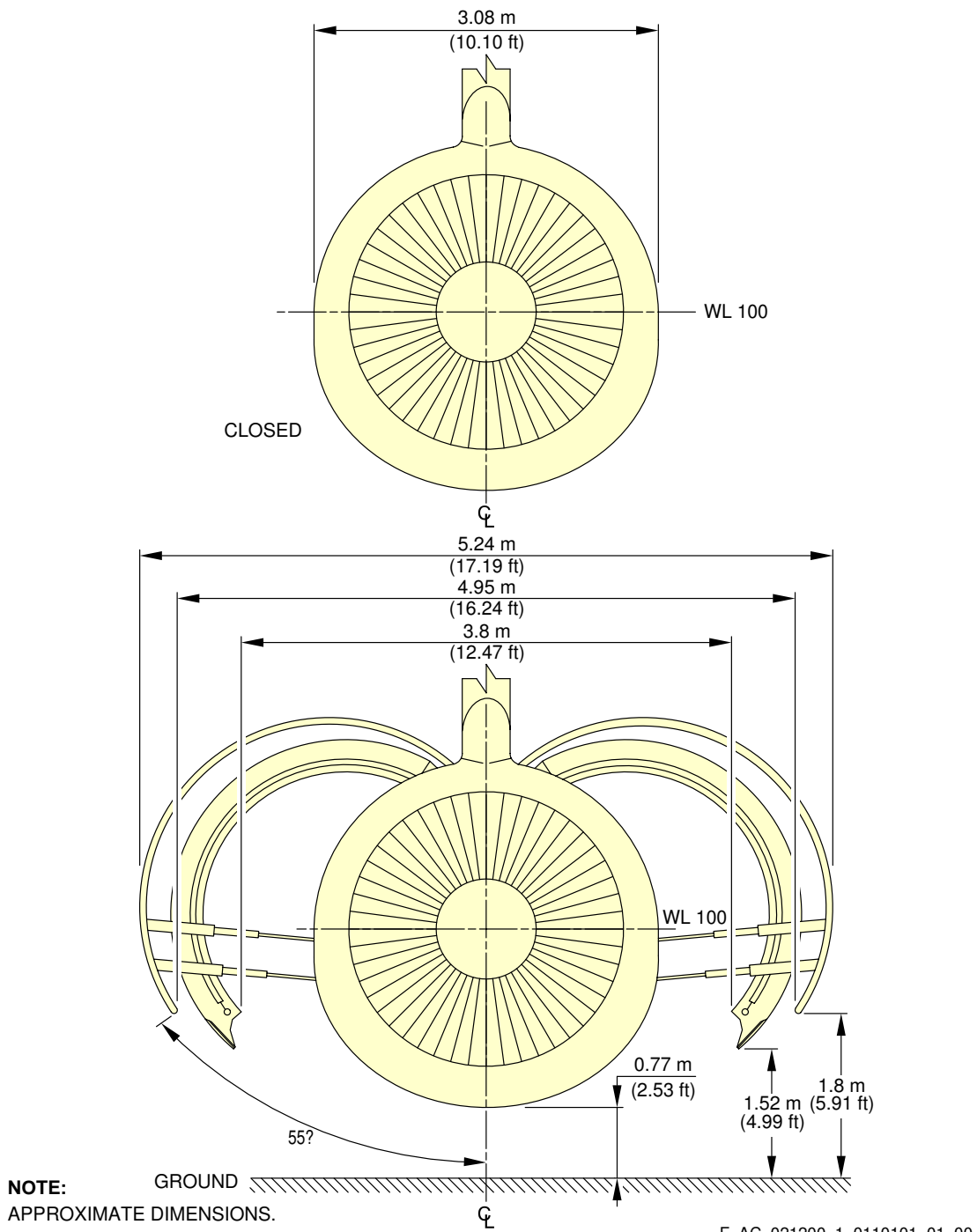

Engine and Nacelle
Fan Cowls - GE CF6-80E1
FIGURE-2-12-0-991-011-A01

**ON A/C A330-200 A330-300

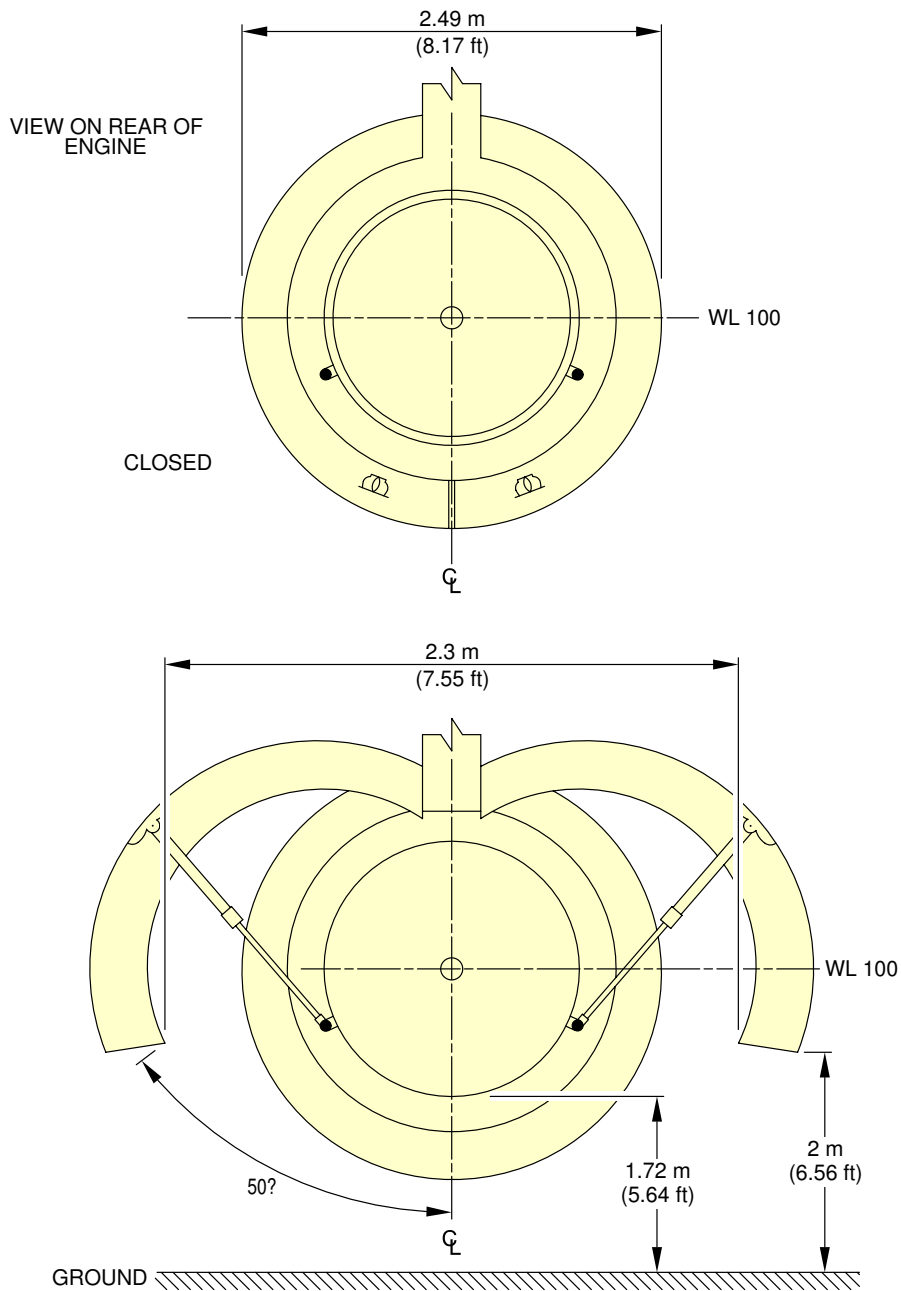

NOTE:
APPROXIMATE DIMENSIONS.

F_AC_021200_1_0120101_01_00

Engine and Nacelle
Thrust Reverser Cowls - GE CF6-80E1
FIGURE-2-12-0-991-012-A01

**ON A/C A330-800 A330-900

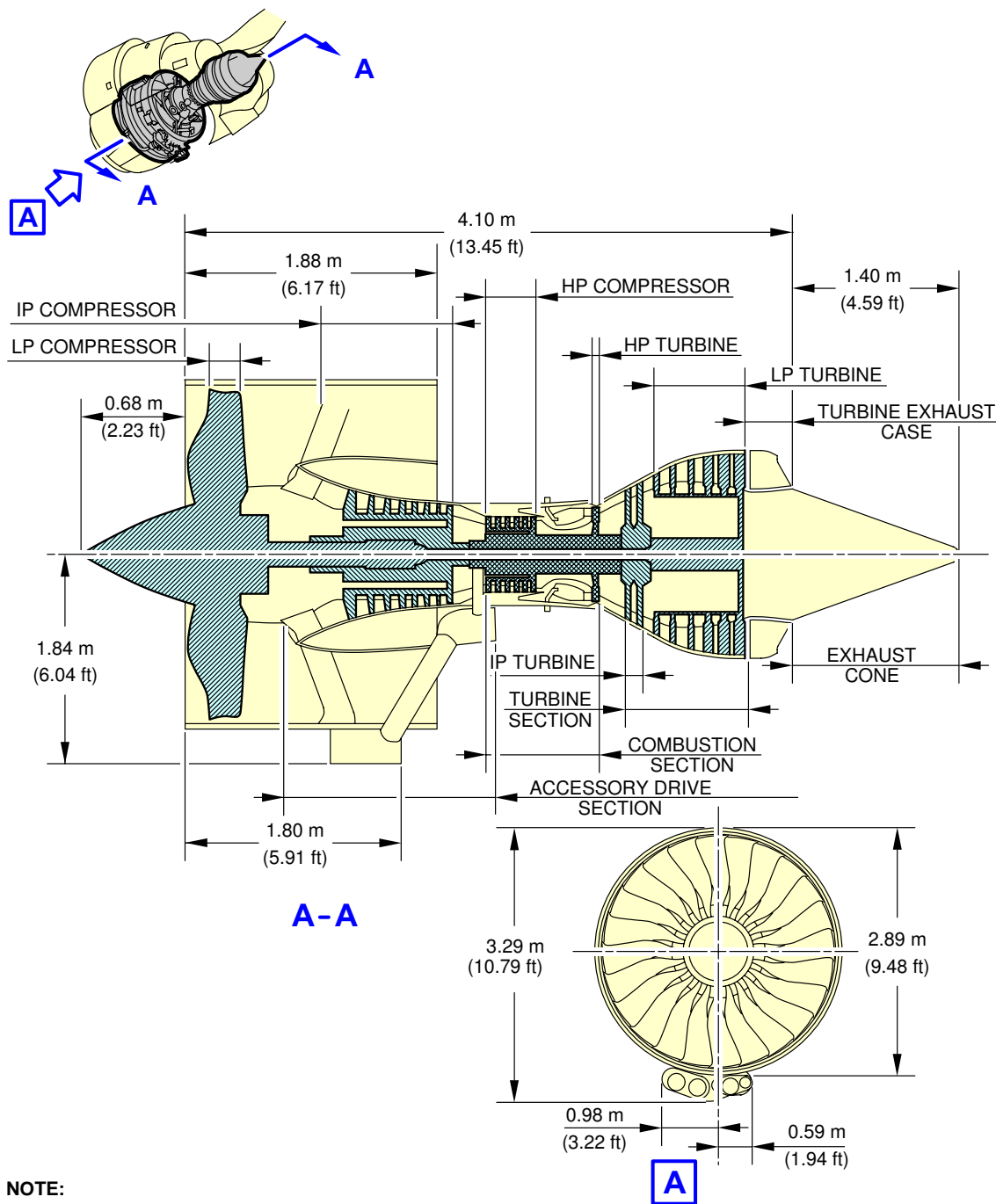

NOTE:
APPROXIMATE DIMENSIONS.

F_AC_021200_1_0260101_01_00

Engine and Nacelle
Engine Dimensions - TRENT 7000
FIGURE-2-12-0-991-026-A01

**ON A/C A330-800 A330-900

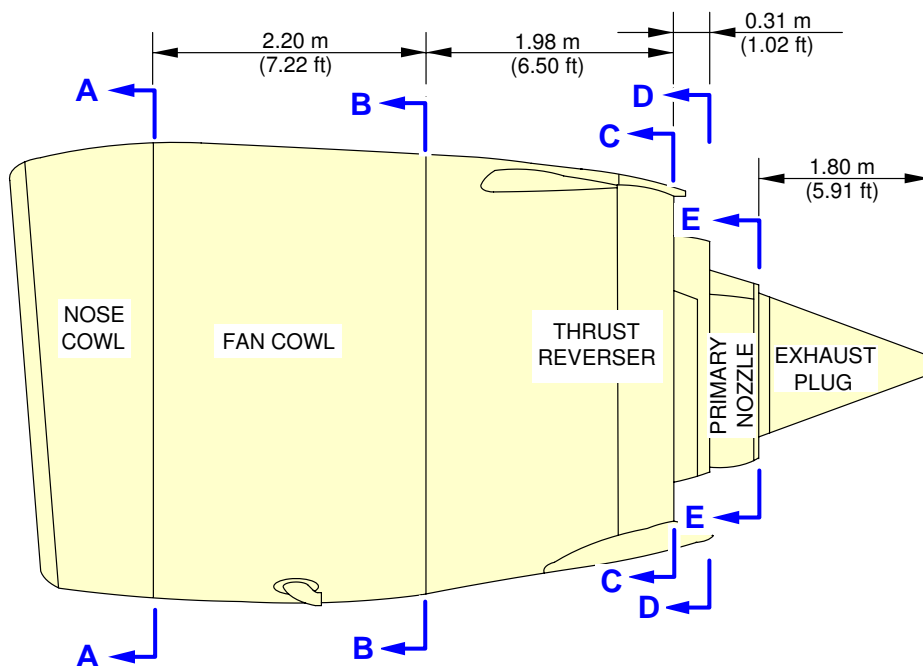

	W	U	V
A-A	3.65 m (11.98 ft)	TBD	TBD
B-B	TBD	TBD	TBD
C-C	TBD	TBD	TBD
D-D	TBD	TBD	TBD
E-E	TBD	TBD	TBD

DISTANCE FROM THE NOSE	A330-800	A330-900
INBOARD ENGINE	TBD	TBD
OUTBOARD ENGINE	TBD	TBD

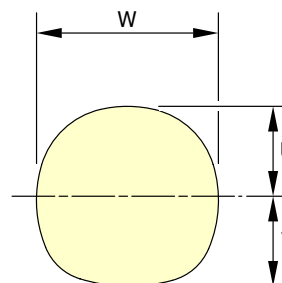

NOTE:
APPROXIMATE DIMENSIONS.

F_AC_021200_1_0270101_01_00

Engine and Nacelle
Nacelle Dimensions - TRENT 7000
FIGURE-2-12-0-991-027-A01

2-12-1 Auxiliary Power Unit

****ON A/C A330-200 A330-200F A330-300 A330-800 A330-900**

Auxiliary Power Unit

1. General

The Auxiliary Power Unit (APU) and its related mechanical components are installed at the rear part of the fuselage in the tailcone section. The APU compartment is a fireproof area (identified as the Fire Zone).

The APU is a pneumatic and shaft-power gas-turbine engine and is used for the ground and in-flight power supply of the aircraft.

The APU supplies:

- mechanical shaft-power to operate a generator
- bleed-air to the Main Engine Start (MES) and the Environmental Control System (ECS).

A part of the automatic system, with the pneumatic and the electromechanical controls, operates the start and the acceleration functions of the APU.

An air intake system with a flap-type door is installed in front of the APU compartment. The exhaust gases pass overboard at the end of the fuselage cone.

2. Powerplant

The APU is the Garrett Gas-Turbine Compressor Power-unit (GTCP) 331-350C with a single shaft engine.

The engine is the primary component of the APU, which is of the modular design. The modules of the engine are:

- The power section
- The load compressor
- The accessory drive gearbox with LRU(s).

The power section has a two-stage centrifugal compressor, a reverse-flow annular combustion chamber and a three-stage axial turbine. The power section directly operates the one-stage centrifugal load-compressor which supplies the bleed-air to the pneumatic system. The inlet guide vanes as part of the load compressor, control the airflow.

The power section also operates the gearbox which is attached to the load compressor. The following LRU's are mounted on the gearbox :

- the APU generator,
- the starter motor,
- the oil pump,
- the Fuel Control Unit (FCU),
- the cooling air fan.

The APU has a gearbox-driven oil-cooled AC generator.

The cooling air and ventilation system of the APU supplies the air for cooling of the APU and the equipment on the APU. It also supplies the air for ventilation of the APU compartment.

3. Control circuit

The Electronic Control Box (ECB), which controls the Fuel Control Unit (FCU) and the Inlet Guide Vanes (IGV), keeps the APU at a constant speed. The control circuit is used to start the APU, to shut it down, to control it and to prevent internal failure.

4. Controls and Indication

The primary APU controls and indications are installed in the overhead panel, on the center pedestal panel and on the forward center panel. External APU panels are also installed on the nose landing gear and on the refuel/defuel panel, to initiate an APU emergency shut-down.

**ON A/C A330-200 A330-200F A330-300 A330-800 A330-900

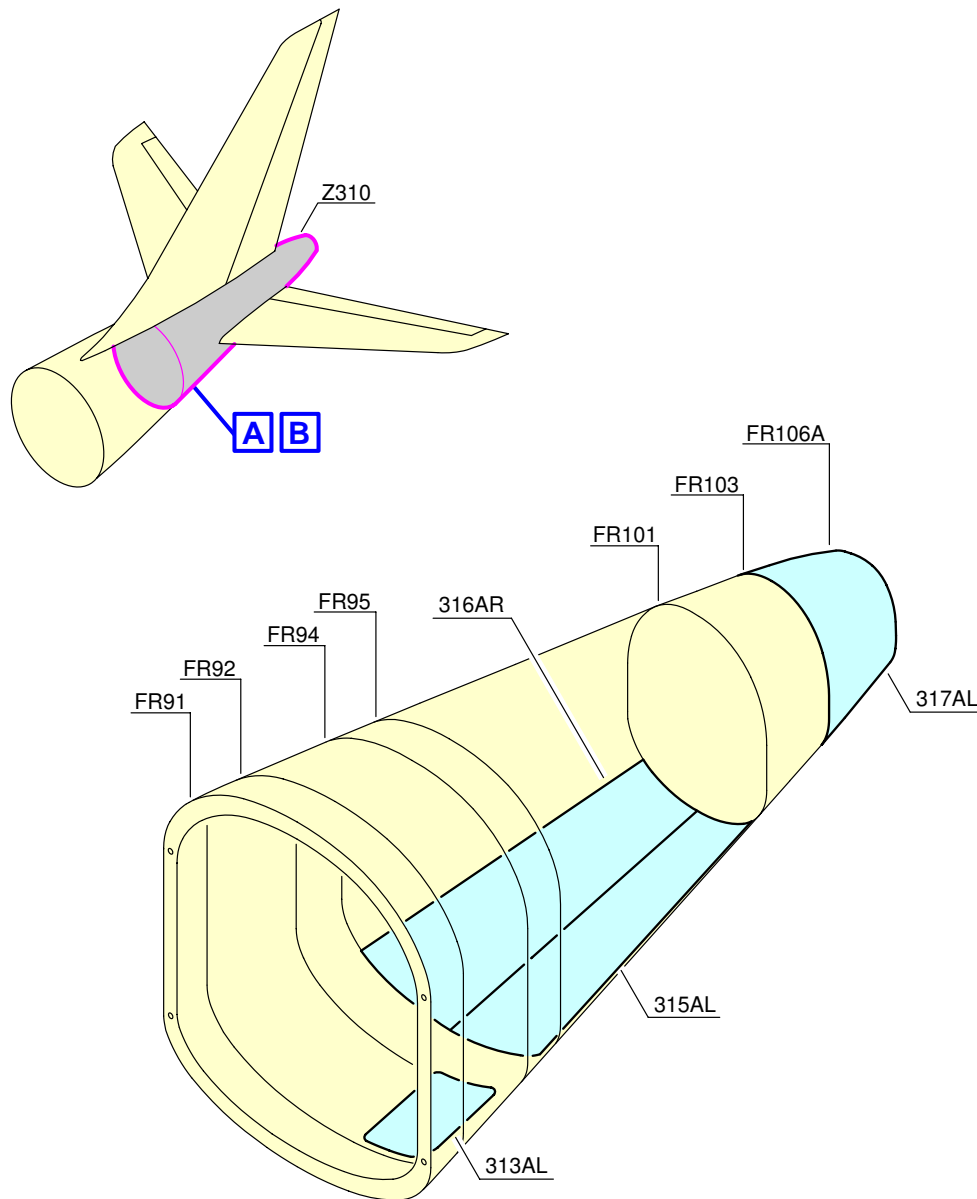

A

F_AC_021201_1_0020101_01_00

Auxiliary Power Unit
Access Doors (Sheet 1 of 2)
FIGURE-2-12-1-991-002-A01

**ON A/C A330-200 A330-200F A330-300 A330-800 A330-900

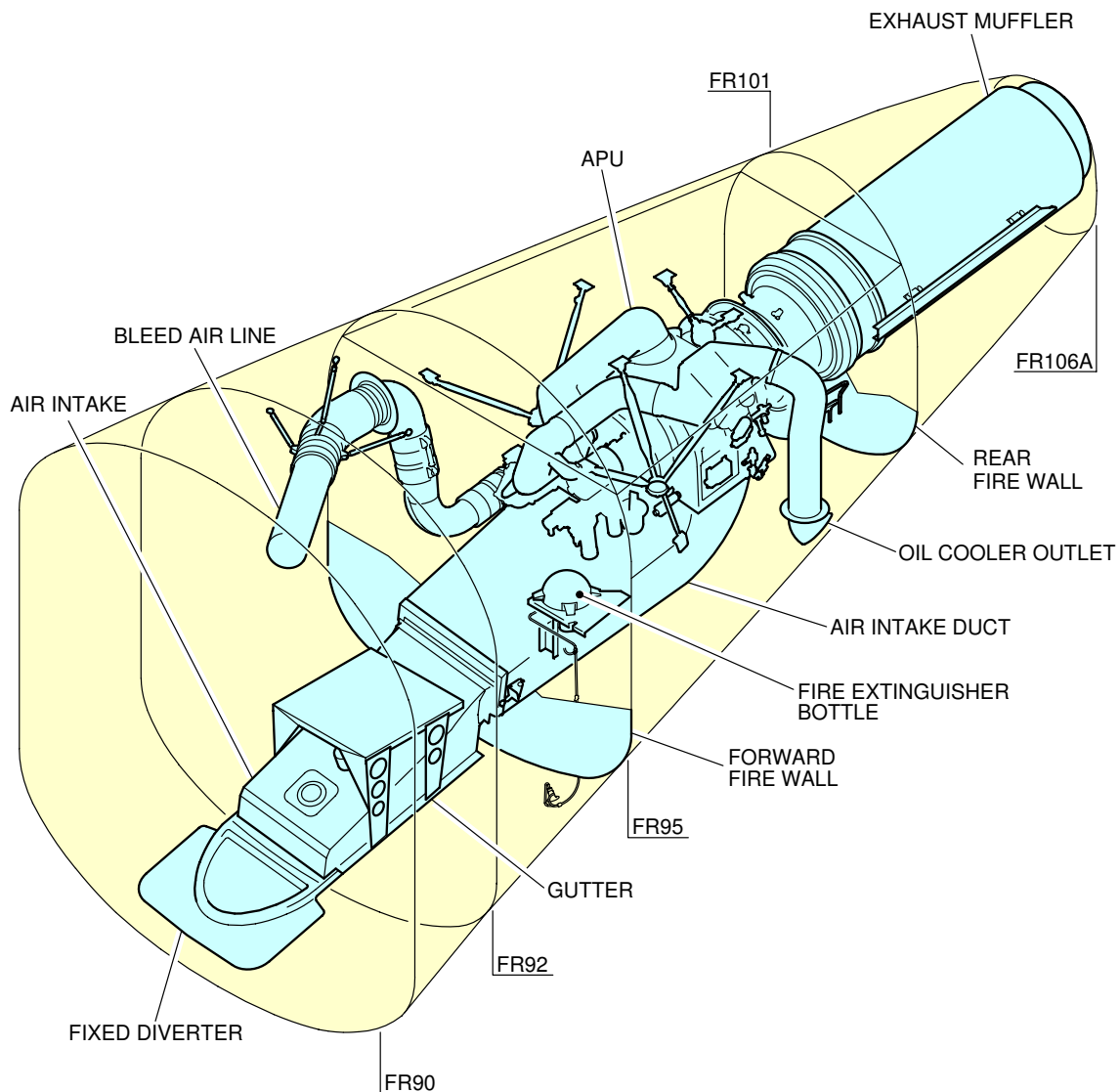

B

F_AC_021201_1_0020102_01_00

Auxiliary Power Unit
General Layout (Sheet 2 of 2)
FIGURE-2-12-1-991-002-A01

2-13-0 Levelling, symmetry and Alignment****ON A/C A330-200 A330-200F A330-300 A330-800 A330-900**Leveling, Symmetry and Alignment****ON A/C A330-200 A330-300 A330-800 A330-900****1. Quick Leveling**

There are three alternative procedures to level the aircraft:

- Quick leveling procedure with Air Data/Inertial Reference System (ADIRS)
- Quick leveling procedure with a spirit level in the passenger compartment
- Quick leveling procedure with a spirit level in the FWD cargo compartment.

****ON A/C A330-200F****2. Quick Leveling**

There are three alternative procedures to level the aircraft:

- Quick leveling procedure with Air Data/Inertial Reference System (ADIRS)
- Quick leveling procedure with a spirit level in the Main Deck cargo compartment
- Quick leveling procedure with a spirit level in the FWD cargo compartment.

****ON A/C A330-200 A330-200F A330-300 A330-800 A330-900****3. Precision Leveling**

For precise leveling, it is necessary to install sighting rods in the receptacles located under the fuselage (points 12 and 13 for longitudinal leveling) and under the wings (points 2LH and 2RH for lateral leveling) and use a sighting tube. With the aircraft on jacks, adjust the jacks until the reference marks on the sighting rods are aligned in the sighting plane (aircraft level).

4. Symmetry and Alignment Check

Possible deformation of the aircraft is measured by photogrammetry.

**ON A/C A330-200 A330-800

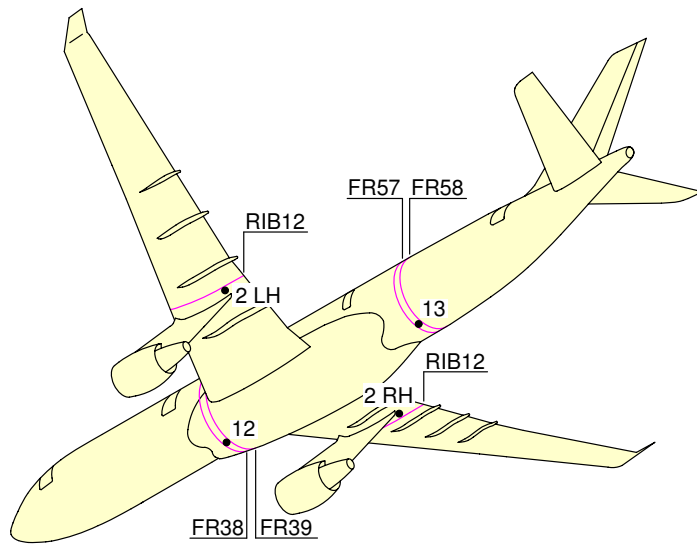

F_AC_021300_1_0010101_01_00

Location of Leveling Points
FIGURE-2-13-0-991-001-A01

**ON A/C A330-300 A330-900

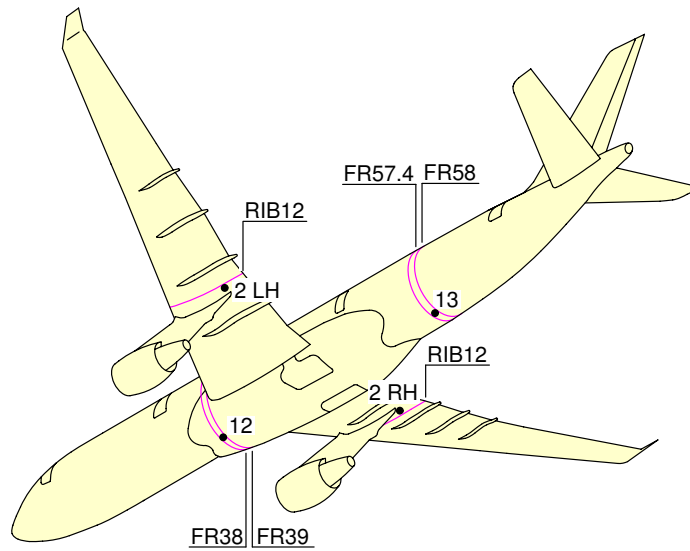

F_AC_021300_1_0020101_01_00

Location of Leveling Points
FIGURE-2-13-0-991-002-A01

**ON A/C A330-200F

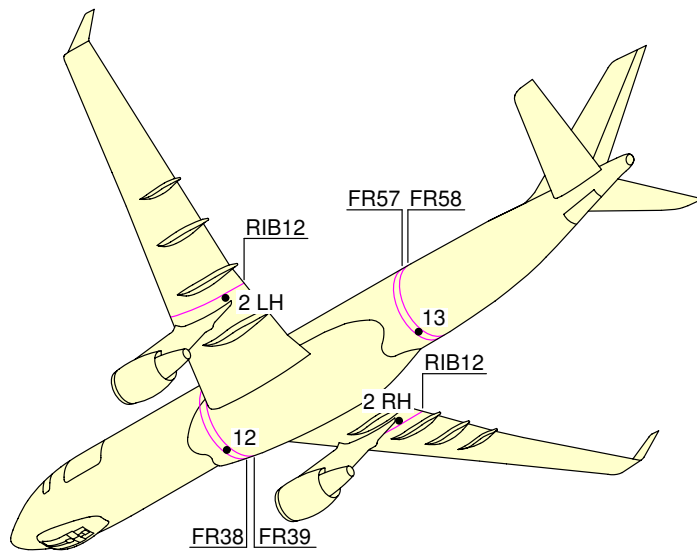

F_AC_021300_1_0030101_01_00

Location of Leveling Points
FIGURE-2-13-0-991-003-A01

2-14-0 Jacking for Maintenance****ON A/C A330-200 A330-200F A330-300 A330-800 A330-900**Jacking for Maintenance****ON A/C A330-200 A330-800 A330-900**

1. Aircraft Jacking Points for Maintenance

A. General

- (1) The A330-200/-800/-900 can be jacked:
 - At not more than 152 000 kg (335 103 lb),
 - Within the limits of the permissible wind speed when the aircraft is jacked outside a closed environment.

B. Primary Jacking Points

- (1) The aircraft is provided with three primary jacking points:
 - One located under the forward fuselage (after FR10A),
 - Two located under the wings (one under each wing), at the intersection of RIB10 and the rear of the spar-datum.
- (2) Three jack adapters (ground equipment) are used as intermediary parts between the aircraft jacking points and the jacks:
 - One male spherical jack adapter at the forward fuselage,
 - Two female spherical jack pad adapters at the wings (one at each wing).

C. Auxiliary Jacking Point (Safety Stay)

- (1) When the aircraft is on jacks, a safety stay is placed under the fuselage at FR87 to prevent tail tipping caused by accidental displacement of the aircraft center of gravity.
- (2) The safety point must not be used for lifting the aircraft.
- (3) One male spherical stay adapter (ground equipment) is used as an intermediary part between the aircraft safety point and the stay.

****ON A/C A330-300**

2. Aircraft Jacking Points for Maintenance

A. General

- (1) The A330-300 can be jacked:
 - At not more than 152 000 kg (335 103 lb),
 - Within the limits of the permissible wind speed when the aircraft is jacked outside a closed environment.

B. Primary Jacking Points

- (1) The aircraft is provided with three primary jacking points:
 - One located under the forward fuselage (after FR10A),

- Two located under the wings (one under each wing), at the intersection of RIB10 and the rear of the spar-datum.
- (2) Three jack adapters (ground equipment) are used as intermediary parts between the aircraft jacking points and the jacks:
 - One male spherical jack adapter at the forward fuselage,
 - Two female spherical jack pad adapters at the wings (one at each wing).
- C. Auxiliary Jacking Point (Safety Stay)
 - (1) When the aircraft is on jacks, a safety stay is placed under the fuselage at FR85 to prevent tail tipping caused by accidental displacement of the aircraft center of gravity.
 - (2) The safety point must not be used for lifting the aircraft.
 - (3) One male spherical stay adapter (ground equipment) is used as an intermediary part between the aircraft safety point and the stay.

****ON A/C A330-200F**

3. Aircraft Jacking Points for Maintenance

A. General

- (1) The A330-200F can be jacked:
 - At not more than 136 000 kg (299 829 lb),
 - Within the limits of the permissible wind speed when the aircraft is jacked outside a closed environment.

B. Primary Jacking Points

- (1) The aircraft is provided with three primary jacking points:
 - One located under the forward fuselage (at FR10A), covered by nose fairing panel 125AL.
 - Two located under the wings (one under each wing), at the intersection of RIB10 and the rear of the spar-datum.
- (2) Three jack adapters (ground equipment) are used as intermediary parts between the aircraft jacking points and the jacks:
 - One male spherical jack adapter at the forward fuselage,
 - Two female spherical jack pad adapters at the wings (one at each wing).

C. Auxiliary Jacking Point (Safety Stay)

- (1) When the aircraft is on jacks, a safety stay is placed under the fuselage at FR87 to prevent tail tipping caused by accidental displacement of the aircraft center of gravity.
- (2) The safety point must not be used for lifting the aircraft.
- (3) One male spherical stay adapter (installed on the aircraft) is used as an intermediary part between the aircraft safety point and the stay.

****ON A/C A330-200 A330-300 A330-800 A330-900**

4. Jacks and Safety Stay

A. Jack Design

- (1) The maximum eligible loads given in the table (Ref. FIGURE 2-14-0-991-001-A FIGURE 2-14-0-991-001-B FIGURE 2-14-0-991-001-D FIGURE 2-14-0-991-001-E) are the maximum loads applicable on jack fittings.
- (2) In fully retracted position (jack stroke at minimum), the height of the jack is such that the jack may be placed beneath the aircraft under the most adverse conditions, namely, tires deflated and shock absorbers depressurized, with sufficient clearance between the aircraft jacking point and the jack upper end.
- (3) The lifting jack stroke enables the aircraft to be jacked up so that the Fuselage Datum Line (FDL) may be positioned up to 7.2 m (23.62 ft) from the ground to allow all required maintenance procedures and in particular, the removal/installation of the landing-gear shock absorbers.

B. Safety Stay

The stay stroke enables the aircraft tail to be supported up to the Fuselage Datum Line (FDL) positioned 7.2 m (23.62 ft) from the ground.

****ON A/C A330-200F**

5. Jacks and Safety Stay

A. Jack Design

- (1) The maximum eligible loads given in the table (Ref. FIGURE 2-14-0-991-001-C) are the maximum loads applicable on jack fittings.
- (2) In fully retracted position (jack stroke at minimum), the height of the jack is such that the jack may be placed beneath the aircraft under the most adverse conditions, namely, tires deflated and shock absorbers depressurized, with sufficient clearance between the aircraft jacking point and the jack upper end.
- (3) The lifting jack stroke enables the aircraft to be jacked up so that the Fuselage Datum line (FDL) may be positioned up to 7.2 m (23.62 ft) from the ground to allow all required maintenance procedures and in particular, the removal/installation of the landing-gear shock absorbers.
- (4) At the forward jacking point, specific jack dimensions are necessary (Ref. FIGURE 2-14-0-991-022-A):
 - Maximum jack tube diameter 320 mm (12.6 in),
 - Maximum threaded rod diameter 160 mm (6.3 in),
 - Minimum threaded rod length 250 mm (9.8 in).

B. Safety Stay

The stay stroke enables the aircraft tail to be supported up to the Fuselage Datum Line (FDL) positioned 7.2 m (23.62 ft) from the ground.

**ON A/C A330-200

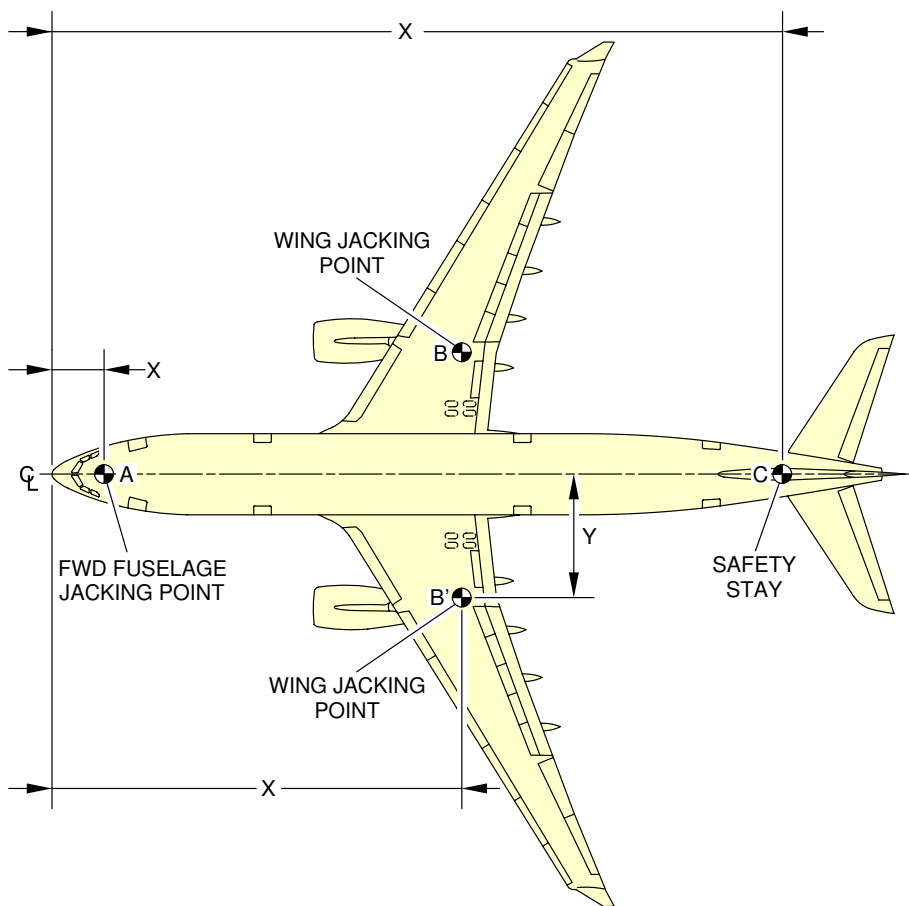

		X		Y		MAXIMUM LOAD ELIGIBLE daN
		m	ft	m	ft	
FWD FUSELAGE JACKING POINT	A	3.58	11.75	0	0	12 300
WING JACKING POINT	B	28.35	93.01	8.51	27.92	73 200
	B'	28.35	93.01	-8.51	-27.92	73 200
SAFETY STAY	C	51.54	169.09	0	0	4 500

NOTE:
SAFETY STAY IS NOT USED FOR JACKING.

F_AC_021400_1_0010101_01_01

Jacking for Maintenance
Jacking Points Location
FIGURE-2-14-0-991-001-A01

****ON A/C A330-300**

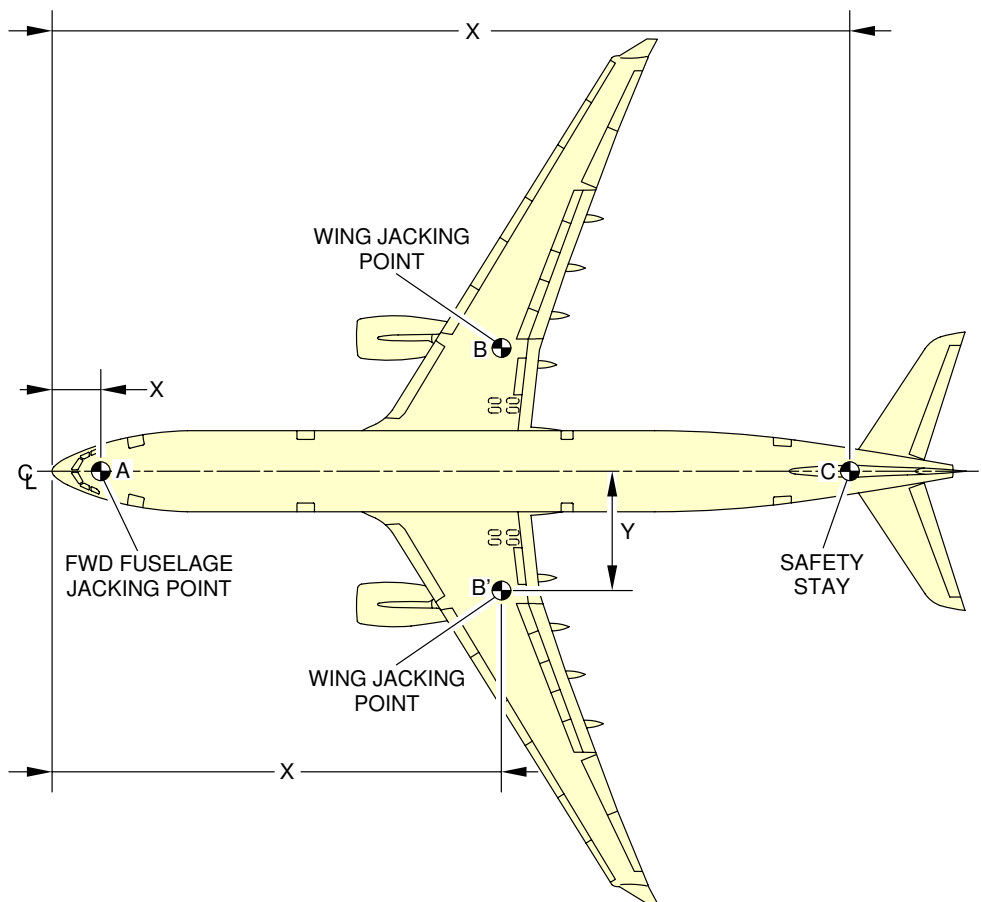

		X		Y		MAXIMUM LOAD ELIGIBLE daN
		m	ft	m	ft	
FWD FUSELAGE JACKING POINT	A	3.58	11.75	0	0	12 300
WING JACKING POINT	B	31.55	103.51	8.51	27.92	73 200
	B'	31.55	103.51	-8.51	-27.92	73 200
SAFETY STAY (PRE-MOD F535-71610)	C	55.81	183.1	0	0	4 500
SAFETY STAY (POST-MOD F535-78031)	C	56.86	186.55	0	0	4 500
SAFETY STAY (WITH MOD)	C	56.86	186.55	0	0	4 500

NOTE:

SAFETY STAY IS NOT USED FOR JACKING.

F_AC_021400_1_0010201_01_01

Jacking for Maintenance
Jacking Points Location
FIGURE-2-14-0-991-001-B01

**ON A/C A330-200F

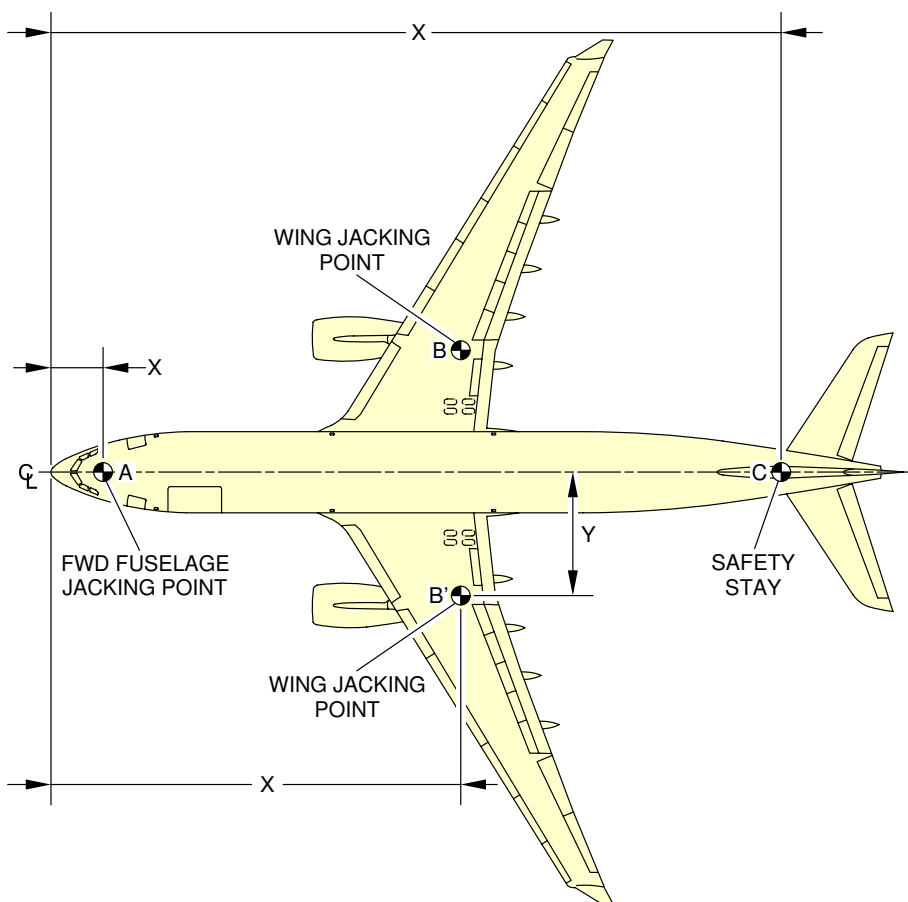

		X		Y		MAXIMUM LOAD ELIGIBLE daN
		m	ft	m	ft	
FWD FUSELAGE JACKING POINT	A	3.57	11.71	0	0	11 250
WING JACKING POINT	B	28.35	93.01	8.51	27.92	65 411
	B'	28.35	93.01	-8.51	-27.92	65 411
SAFETY STAY	C	51.54	169.09	0	0	4 500

NOTE:
SAFETY STAY IS NOT USED FOR JACKING.

F_AC_021400_1_0010301_01_01

Jacking for Maintenance
Jacking Points Location
FIGURE-2-14-0-991-001-C01

****ON A/C A330-800**

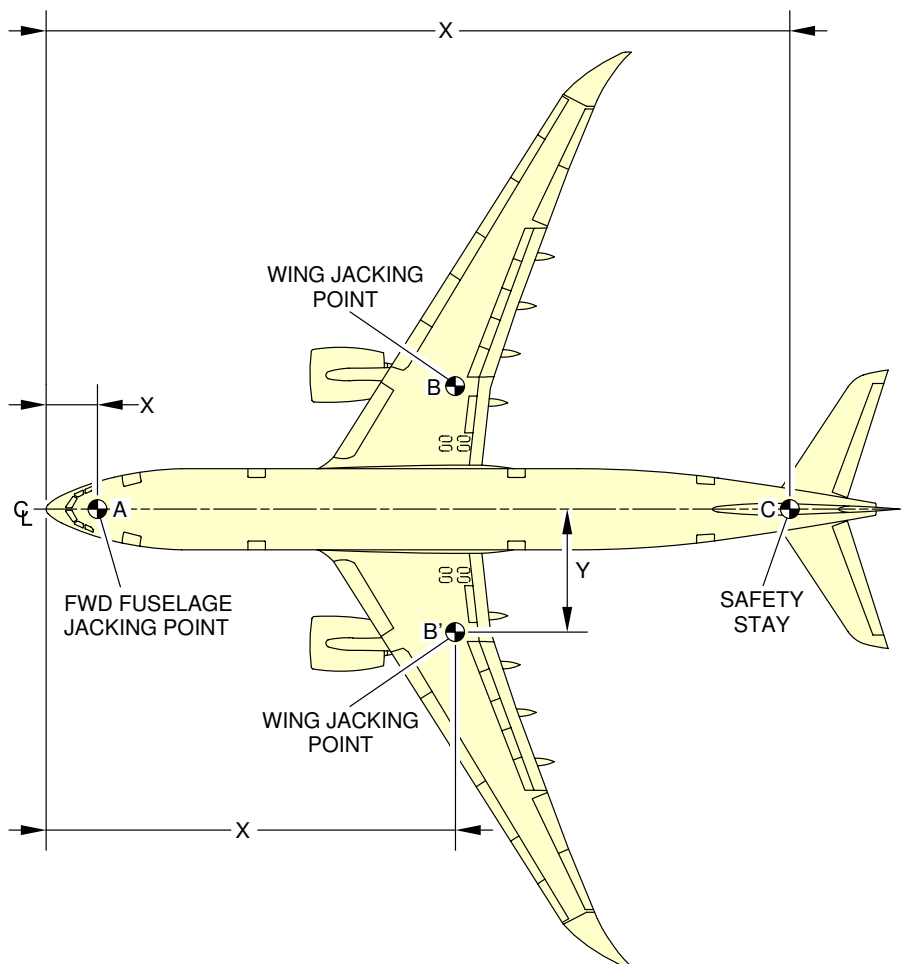

		X		Y		MAXIMUM LOAD ELIGIBLE daN
		m	ft	m	ft	
FWD FUSELAGE JACKING POINT	A	3.58	11.75	0	0	12 300
WING JACKING POINT	B	28.35	93.01	8.51	27.92	73 200
	B'	28.35	93.01	-8.51	-27.92	73 200
SAFETY STAY	C	51.54	169.09	0	0	4 500

NOTE:
SAFETY STAY IS NOT USED FOR JACKING.

F_AC_021400_1_0010401_01_02

Jacking for Maintenance
Jacking Points Location
FIGURE-2-14-0-991-001-D01

****ON A/C A330-900**

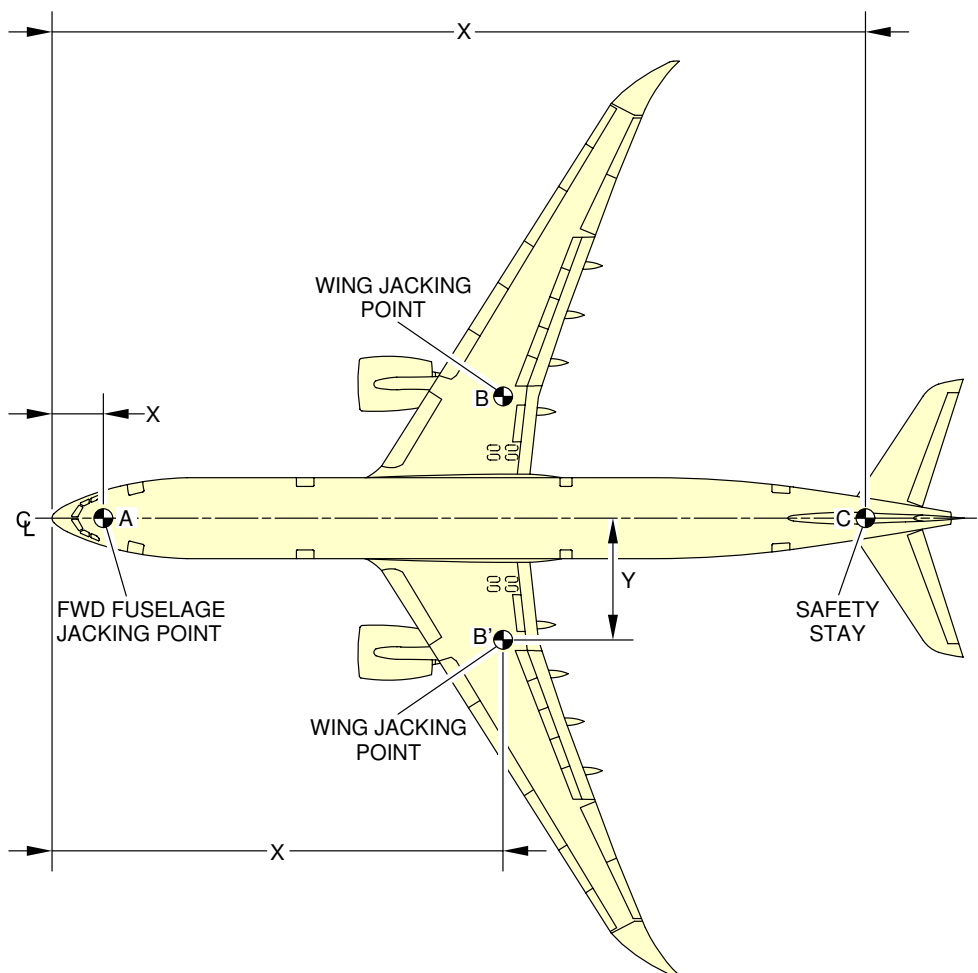

		X		Y		MAXIMUM LOAD ELIGIBLE daN
		m	ft	m	ft	
FWD FUSELAGE JACKING POINT	A	3.58	11.75	0	0	12 300
WING JACKING POINT	B	31.55	103.51	8.51	27.92	73 200
	B'	31.55	103.51	-8.51	-27.92	73 200
SAFETY STAY	C	56.86	186.55	0	0	4 500

NOTE:
SAFETY STAY IS NOT USED FOR JACKING.

F_AC_021400_1_0010501_01_01

Jacking for Maintenance
Jacking Points Location
FIGURE-2-14-0-991-001-E01

**ON A/C A330-200 A330-300 A330-800 A330-900

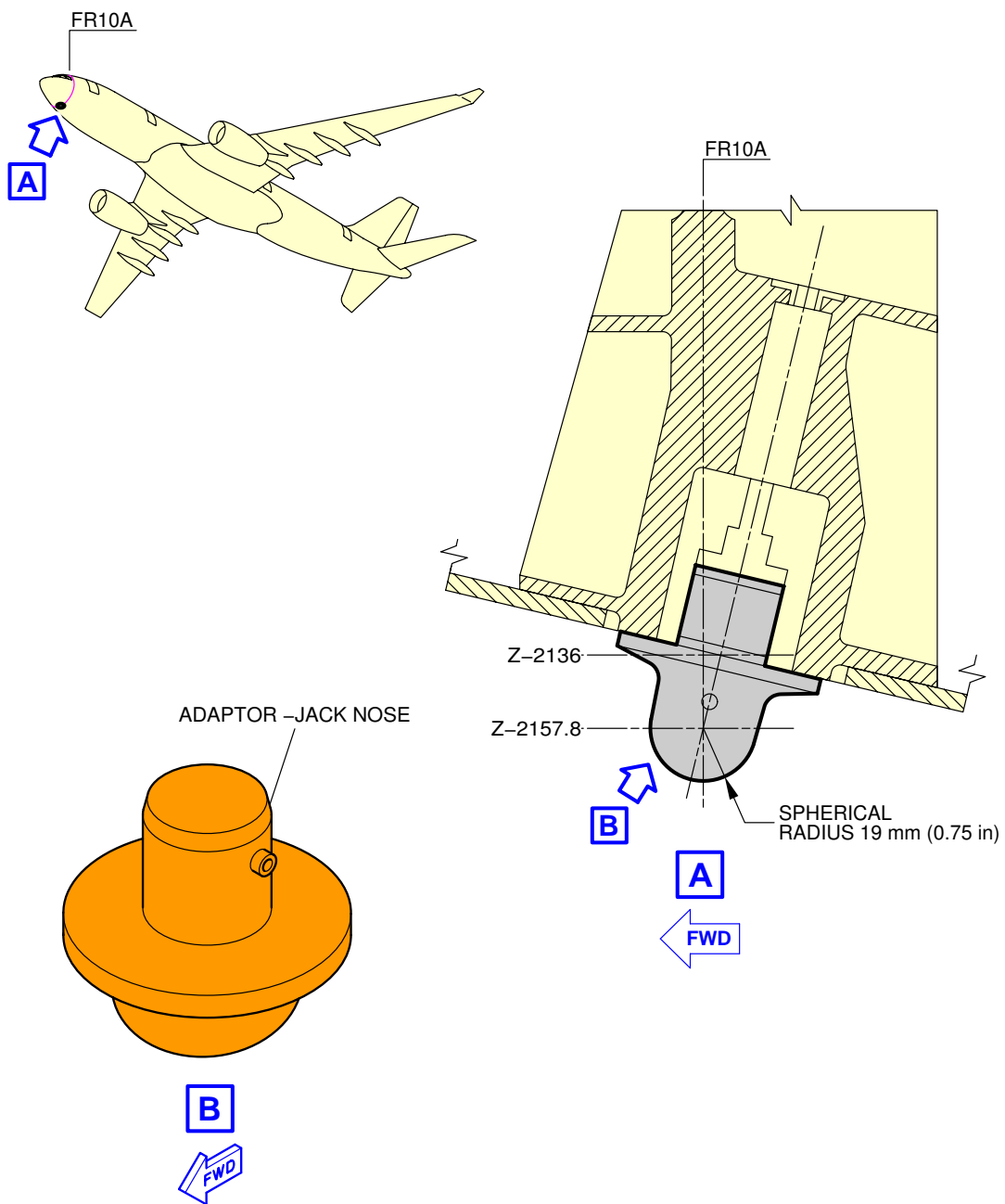

F_AC_021400_1_0020101_01_00

Jacking for Maintenance
Forward Jacking Point
FIGURE-2-14-0-991-002-A01

**ON A/C A330-200F

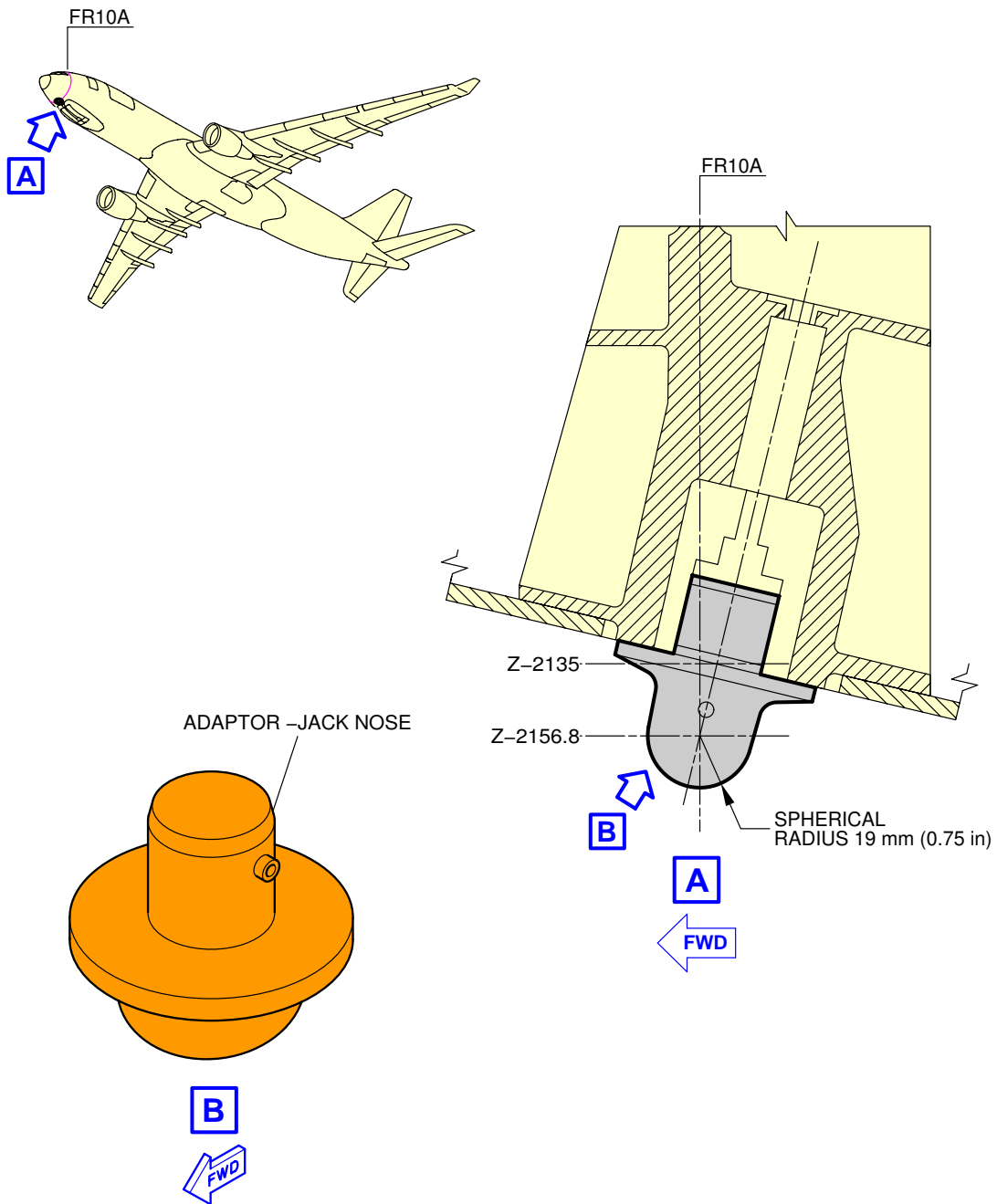

F_AC_021400_1_0020201_01_00

Jacking for Maintenance
Forward Jacking Point
FIGURE-2-14-0-991-002-B01

**ON A/C A330-200 A330-300 A330-800 A330-900

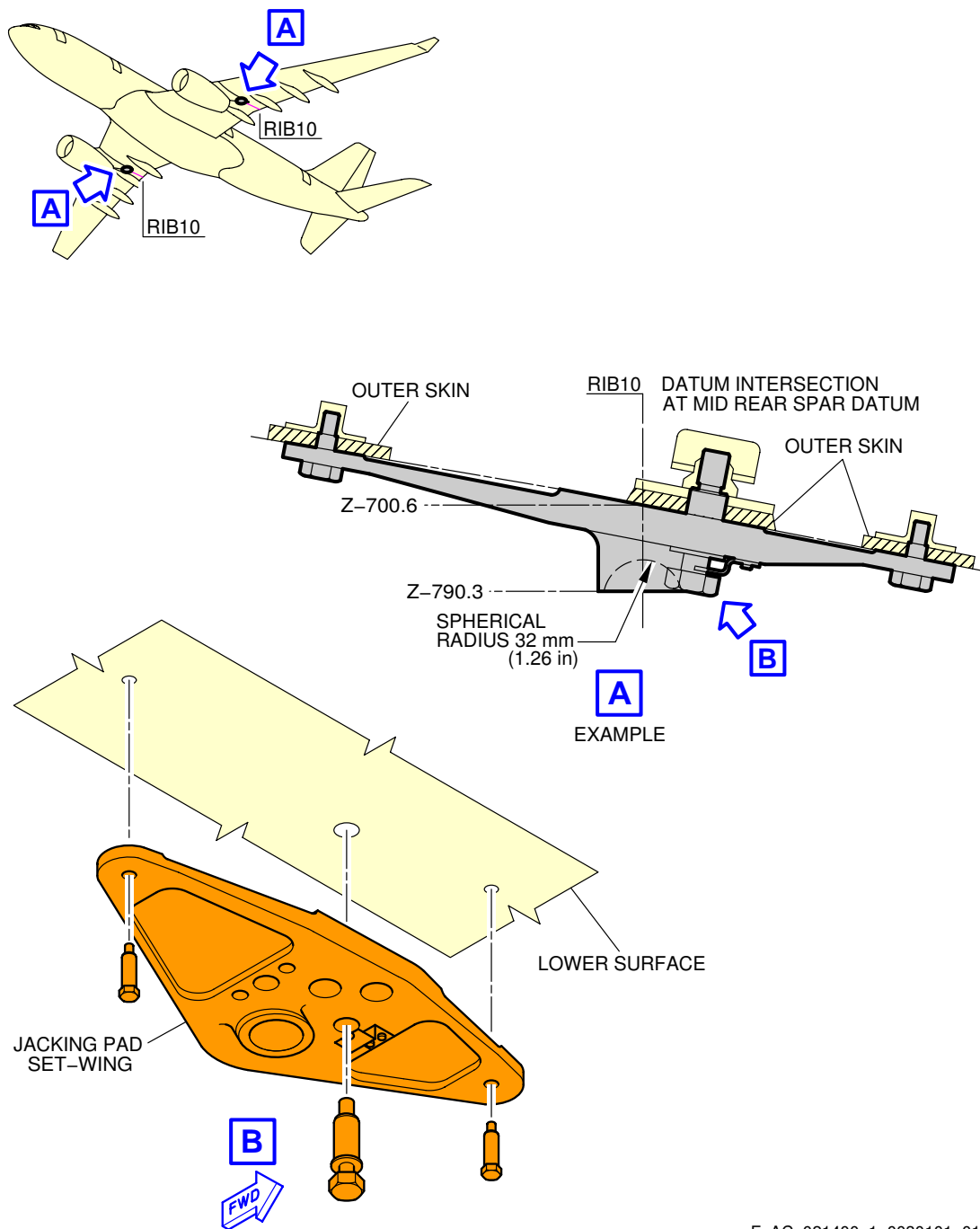

F_AC_021400_1_0030101_01_00

Jacking for Maintenance
Wing Jacking Points
FIGURE-2-14-0-991-003-A01

**ON A/C A330-200F

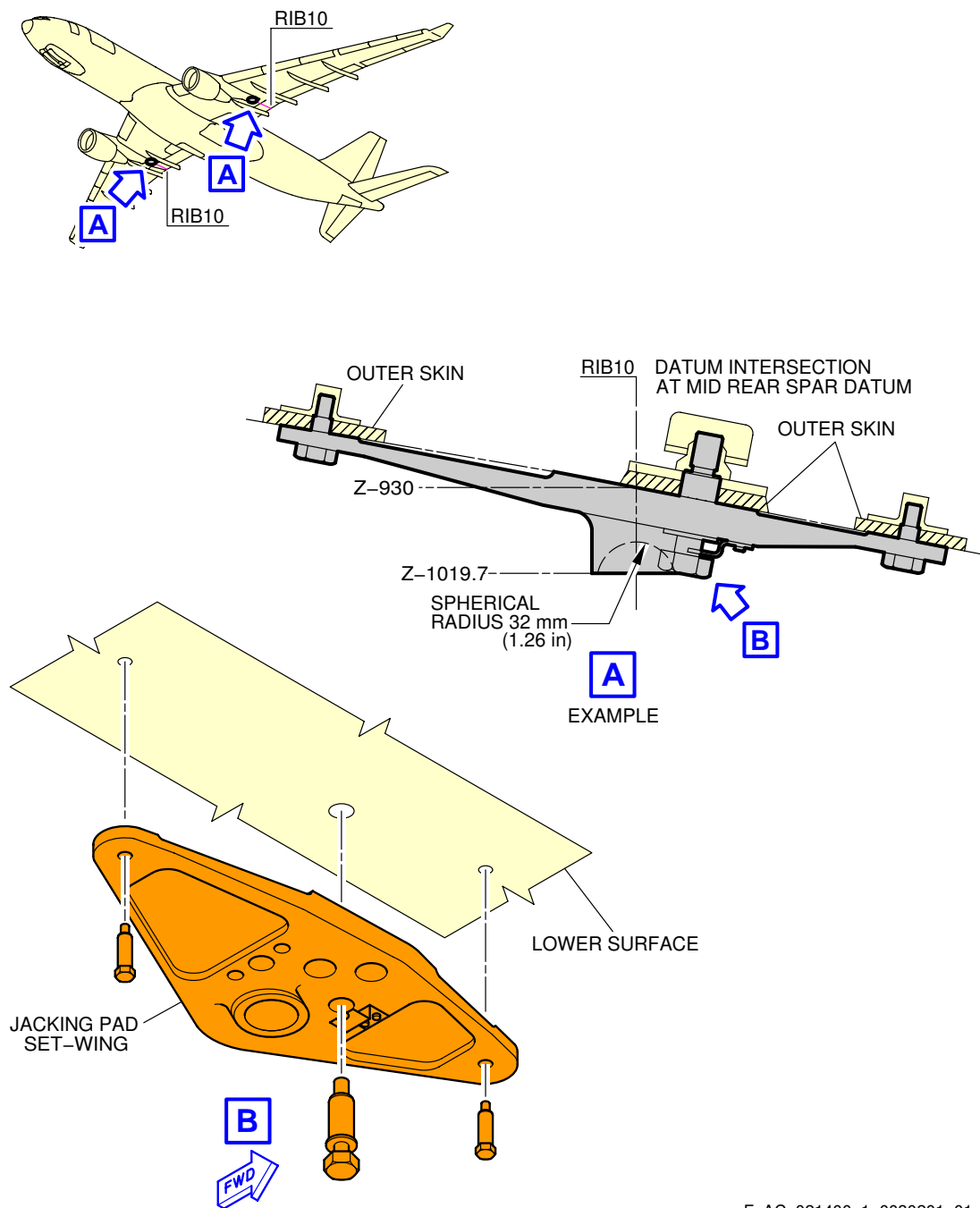

F_AC_021400_1_0030201_01_00

Jacking for Maintenance
Wing Jacking Points
FIGURE-2-14-0-991-003-B01

**ON A/C A330-200 A330-800 A330-900

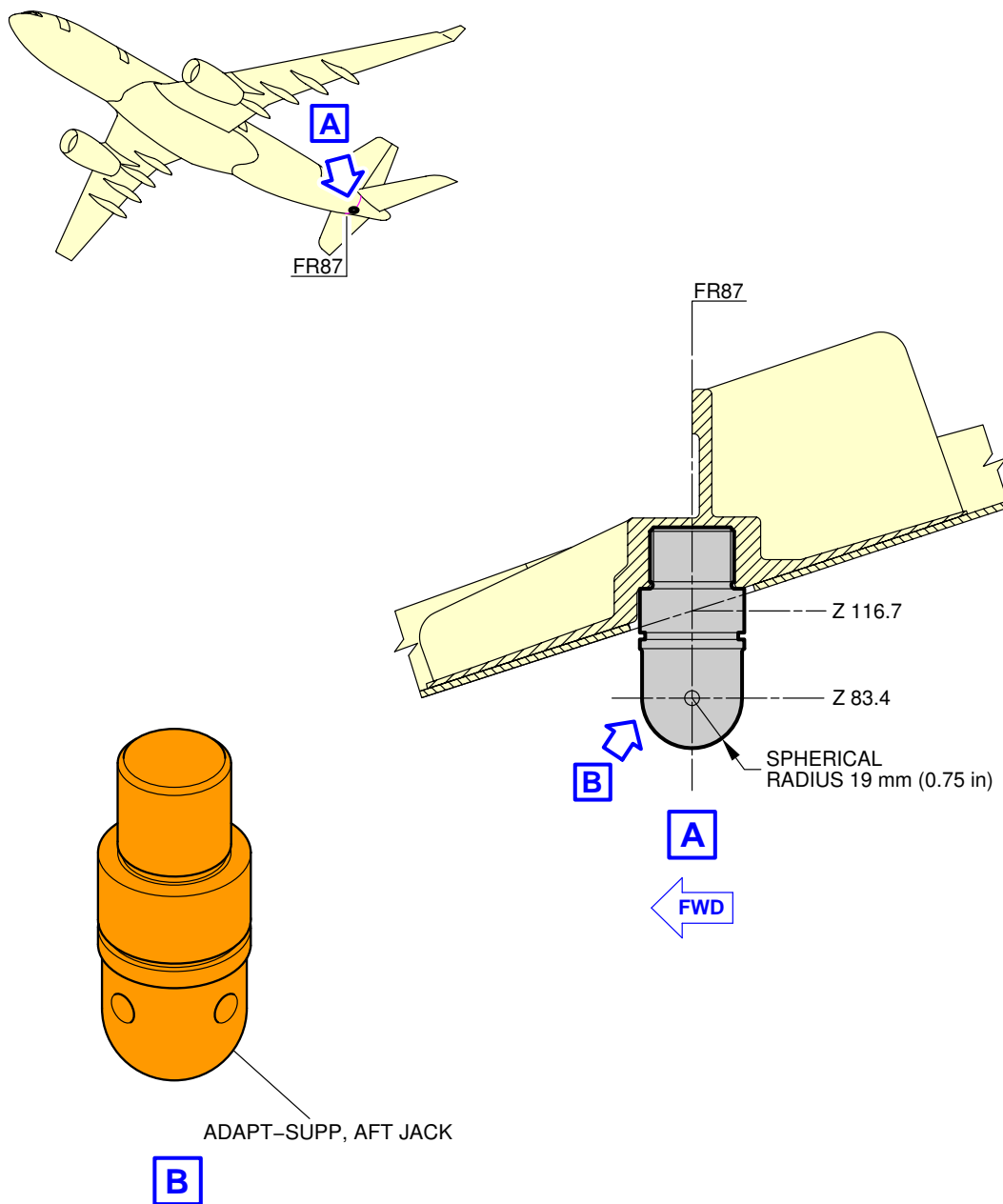

F_AC_021400_1_0040101_01_00

Jacking for Maintenance
Auxiliary Jacking Point - Safety Stay
FIGURE-2-14-0-991-004-A01

**ON A/C A330-300

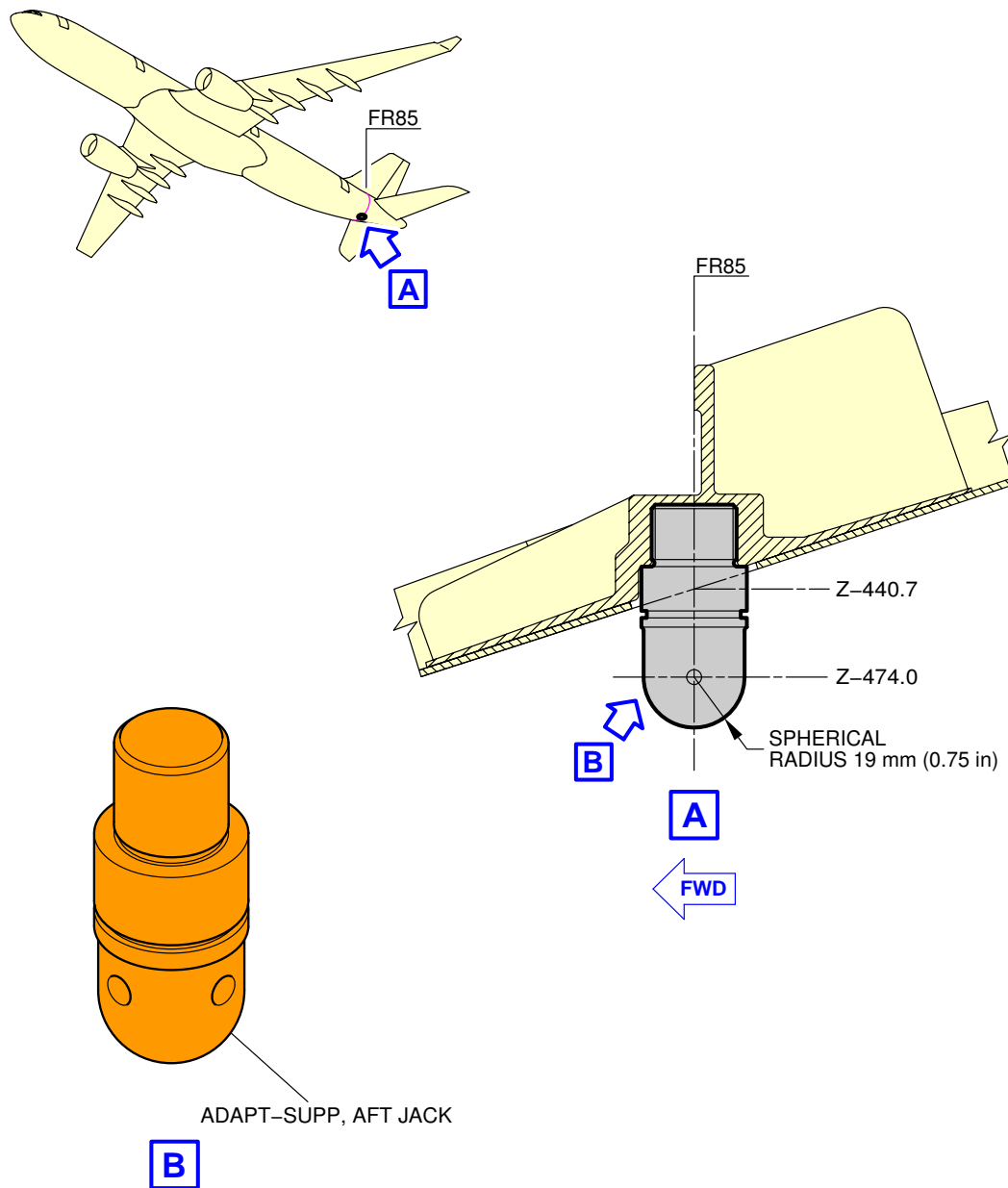

F_AC_021400_1_0040201_01_00

Jacking for Maintenance
Auxiliary Jacking Point - Safety Stay
FIGURE-2-14-0-991-004-B01

**ON A/C A330-200F

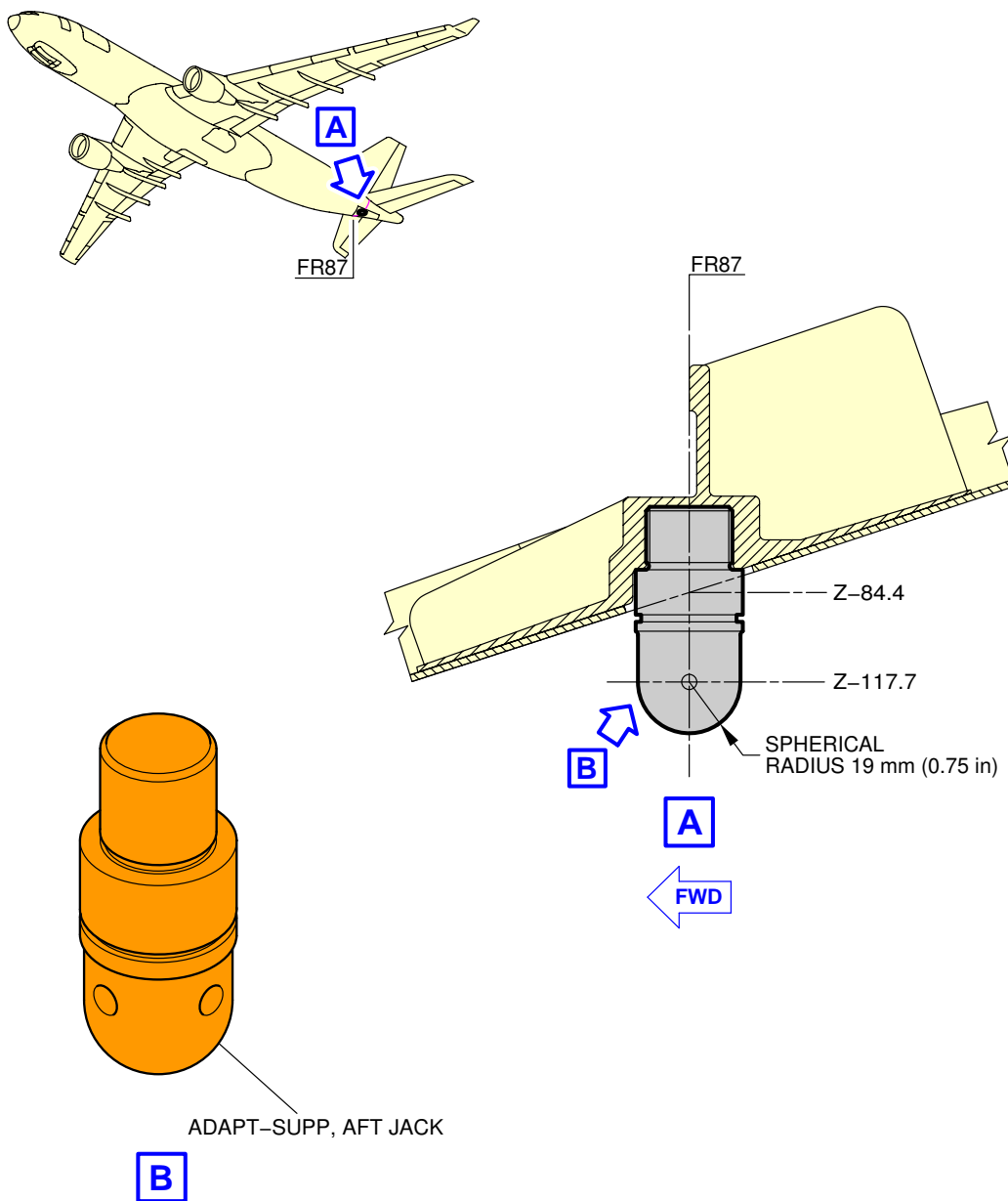

F_AC_021400_1_0040301_01_00

Jacking for Maintenance
Auxiliary Jacking Point - Safety Stay
FIGURE-2-14-0-991-004-C01

**ON A/C A330-200F

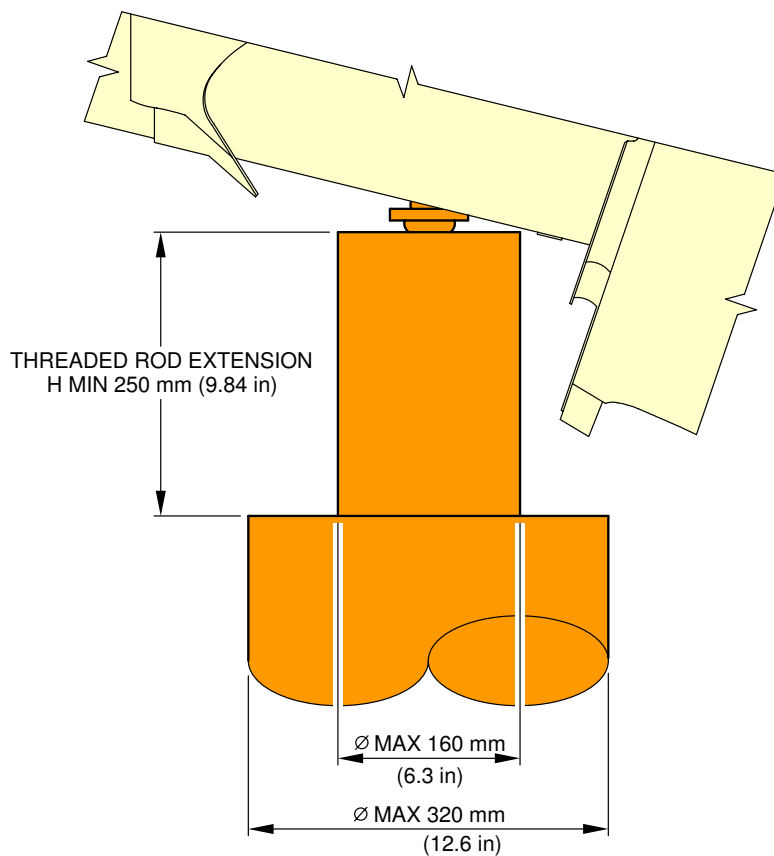
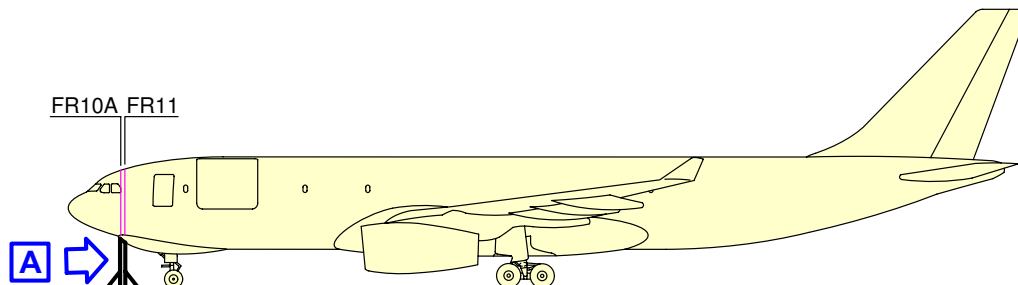

A

CAUTION:

MAKE SURE THAT THE JACK YOU USE IS APPLICABLE FOR THIS AIRCRAFT. IF THE JACK DIMENSIONS ARE NOT IN THE RANGE FOR THIS AIRCRAFT, DAMAGE TO THE AIRCRAFT STRUCTURE CAN OCCUR.

F_AC_021400_1_0220101_01_00

Jacking for Maintenance
Specific Jack-Nose Dimensions
FIGURE-2-14-0-991-022-A01

****ON A/C A330-200**

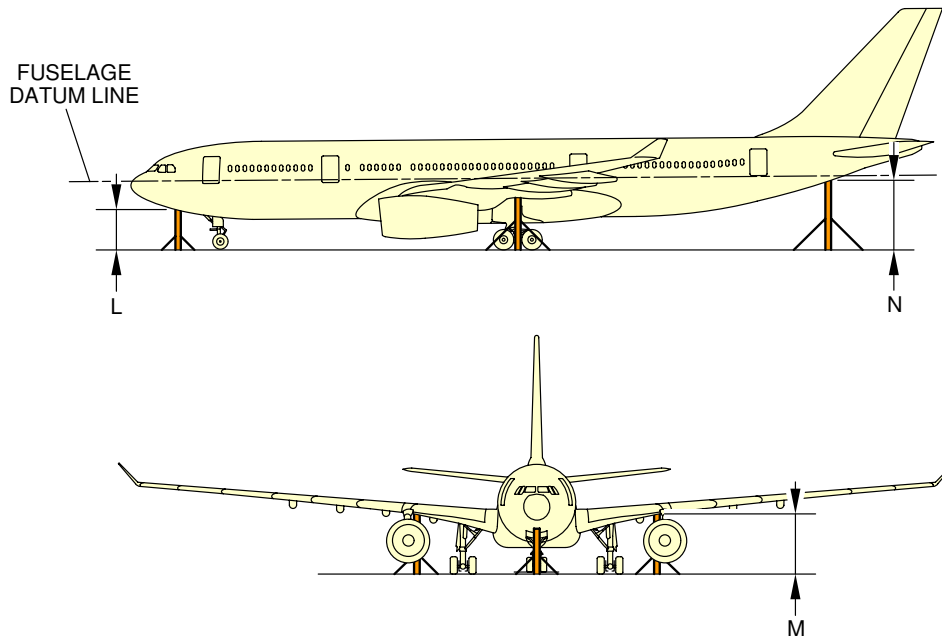

	L	M		N
AIRCRAFT ON WHEELS WITH STANDARD TIRES 01 , MAX. JACK WEIGHT 152 000 kg (335 103 lb)	2.62 m (8.60 ft)	4.59 m (15.06 ft)		5.71 m (18.73 ft)
AIRCRAFT ON WHEELS WITH STANDARD TIRES 01 , OEW 125 206 kg (276 032 lb)	2.63 m (8.63 ft)	4.67 m (15.32 ft)		5.86 m (19.23 ft)
AIRCRAFT ON WHEELS, SHOCK ABSORBER DEFLATED AND FLAT TIRES (RH)	2.66 m (8.73 ft)	(LH) 4.71 m (15.45 ft)	(RH) 3.97 m (13.02 ft)	5.19 m (17.03 ft)
AIRCRAFT ON JACKS, FUSELAGE DATUM LINE PARALLEL TO GROUND AT 6.51 m (21.36 ft), SHOCK-ABSORBER RELAXED, CLEARANCE OF MAIN LANDING GEAR WHEELS: 0.23 m (0.75 ft) (STANDARD TIRES 01), CLEARANCE OF NOSE LANDING GEAR WHEELS: 1.51 m (4.95 ft) (STANDARD TIRES 01)	4.37 m (14.34 ft)	5.81 m (19.06 ft)		6.42 m (21.06 ft)

NOTE:

01 STANDARD TIRES: NOSE LANDING GEAR = 1 050 x 395 R16
MAIN LANDING GEAR = 1 400 x 530 R23

F_AC_021400_1_0050101_01_01

Jacking for Maintenance
Jacking Dimensions
FIGURE-2-14-0-991-005-A01

****ON A/C A330-300**

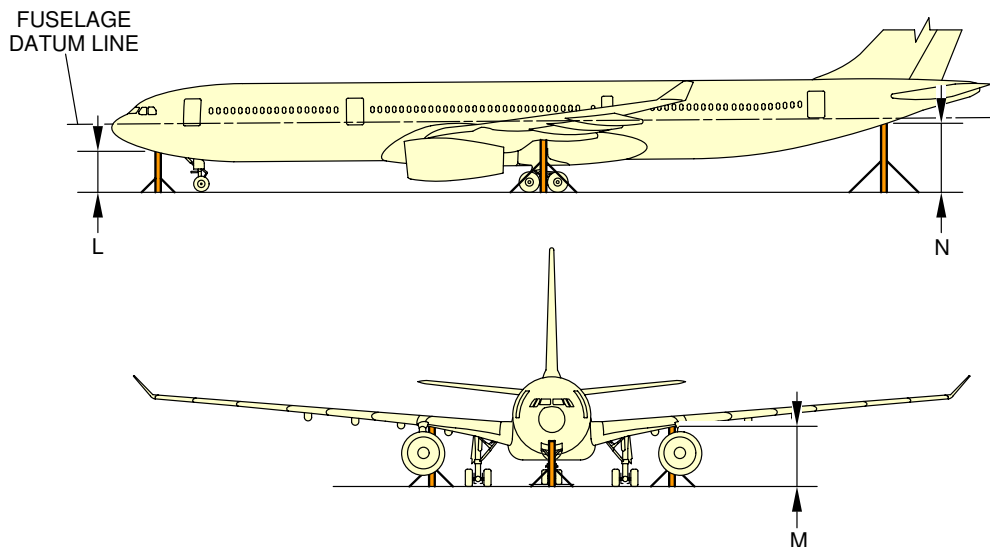

	L	M		N		
				PRE-MOD (F535-71610)	POST-MOD (F535-78031)	WITH MOD
AIRCRAFT ON WHEELS WITH STANDARD TIRES 01 , MAX. JACK WEIGHT 152 000 kg (335 103 lb)	2.65 m (8.69 ft)	4.59 m (15.06 ft)		5.29 m (17.36 ft)	5.66 m (18.57 ft)	5.66 m (18.57 ft)
AIRCRAFT ON WHEELS WITH STANDARD TIRES 01 , OEW = 126 352 kg (278 558 lb)	2.63 m (8.63 ft)	4.67 m (15.32 ft)		5.46 m (17.91 ft)	5.84 m (19.16 ft)	N/A
AIRCRAFT ON WHEELS WITH STANDARD TIRES 01 , OEW = 130 316 kg (287 298 lb)	2.63 m (8.63 ft)	4.66 m (15.29 ft)		N/A	N/A	5.82 m (19.09 ft)
AIRCRAFT ON WHEELS, SHOCK ABSORBER DEFLATED AND FLAT TIRES (RH)	2.68 m (8.79 ft)	(LH) 4.70 m (15.42 ft)	(RH) 3.98 m (13.06 ft)	4.79 m (15.72 ft)	5.16 m (16.93 ft)	5.16 m (16.93 ft)
AIRCRAFT ON JACKS, FUSELAGE DATUM LINE PARALLEL TO GROUND AT 6.51 m (21.36 ft), SHOCK-ABSORBER RELAXED, CLEARANCE OF MAIN LANDING GEAR WHEELS: 0.24 m (0.79 ft) (STANDARD TIRES 01), CLEARANCE OF NOSE LANDING GEAR WHEELS: 1.50 m (4.92 ft) (STANDARD TIRES 01)	4.37 m (14.34 ft)	5.81 m (19.06 ft)		6.07 m (19.91 ft)	6.42 m (21.06 ft)	6.42 m (21.06 ft)

NOTE:

01 STANDARD TIRES: NOSE LANDING GEAR = 1 050 x 395 R16
 MAIN LANDING GEAR = 1 400 x 530 R23

F_AC_021400_1_0050201_01_01

Jacking for Maintenance
 Jacking Dimensions
 FIGURE-2-14-0-991-005-B01

****ON A/C A330-200F**

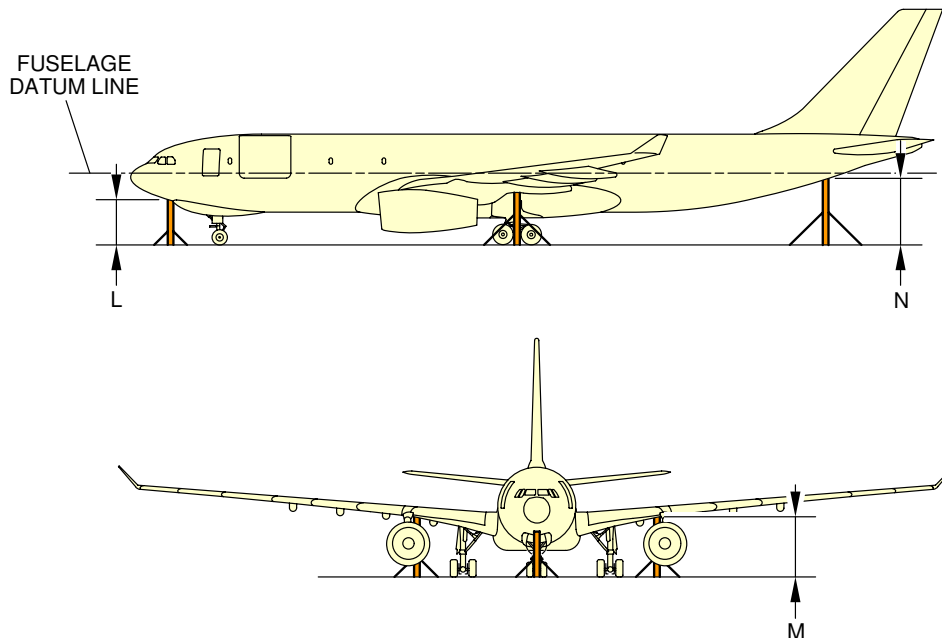

	L	M		N
AIRCRAFT ON WHEELS WITH STANDARD TIRES 01 , MAX. JACK WEIGHT 136 000 kg (299 829 lb)	3.05 m (10.01 ft)	4.64 m (15.22 ft)		5.41 m (17.75 ft)
AIRCRAFT ON WHEELS WITH STANDARD TIRES 01 , OEW 109 000 kg (240 304 lb)	3.06 m (10.04 ft)	4.75 m (15.58 ft)		5.60 m (18.37 ft)
AIRCRAFT ON WHEELS, SHOCK ABSORBER DEFLATED AND FLAT TIRES (RH)	3.11 m (10.20 ft)	(LH) 4.89 m (16.04 ft)	(RH) 3.95 m (12.96 ft)	4.92 m (16.14 ft)
AIRCRAFT ON JACKS, FUSELAGE DATUM LINE PARALLEL TO GROUND AT 6.52 m (21.39 ft), SHOCK-ABSORBER RELAXED, CLEARANCE OF MAIN LANDING GEAR WHEELS: 0.36 m (1.18 ft) (STANDARD TIRES 01), CLEARANCE OF NOSE LANDING GEAR WHEELS: 1.50 m (4.92 ft) (STANDARD TIRES 01)	4.37 m (14.34 ft)	5.81 m (19.06 ft)		6.42 m (21.06 ft)

NOTE:

01 STANDARD TIRES: NOSE LANDING GEAR = 1 050 x 395 R16
MAIN LANDING GEAR = 1 400 x 530 R23

F_AC_021400_1_0050301_01_01

Jacking for Maintenance
Jacking Dimensions
FIGURE-2-14-0-991-005-C01

****ON A/C A330-800**

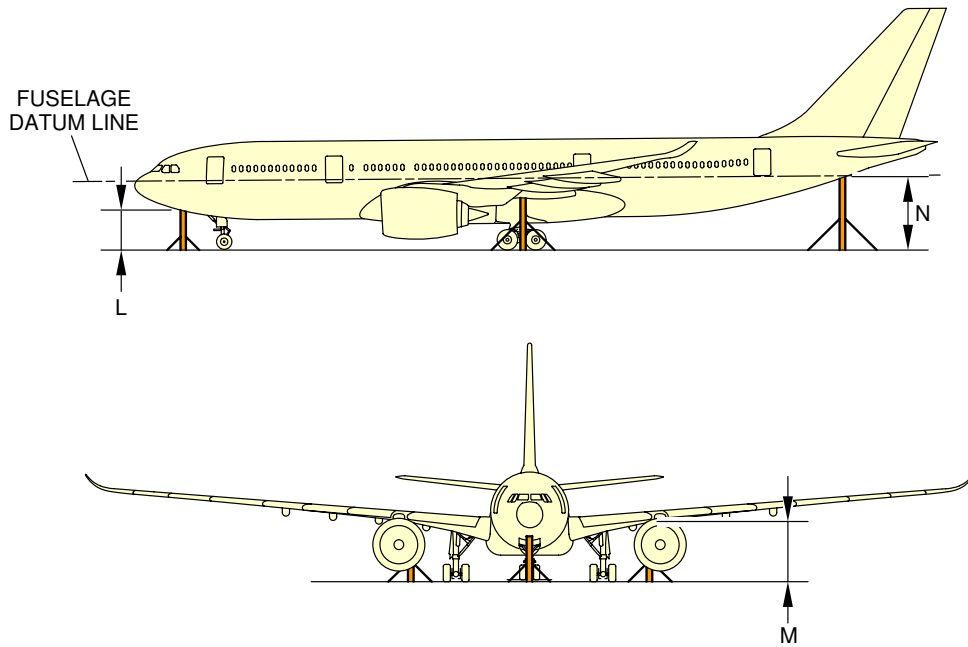

	L	M		N
AIRCRAFT ON WHEELS WITH STANDARD TIRES 01 , MAX. JACK WEIGHT 152 000 kg (335 103 lb)	2.62 m (8.60 ft)	4.59 m (15.06 ft)		5.71 m (18.73 ft)
AIRCRAFT ON WHEELS WITH STANDARD TIRES 01 , OEW 130 499 kg (287 701 lb)	2.62 m (8.60 ft)	4.66 m (15.29 ft)		5.83 m (19.13 ft)
AIRCRAFT ON WHEELS, SHOCK ABSORBER DEFLATED AND FLAT TIRES (RH)	2.66 m (8.73 ft)	(LH) 4.71 m (15.45 ft)	(RH) 3.97 m (13.02 ft)	5.19 m (17.03 ft)
AIRCRAFT ON JACKS, FUSELAGE DATUM LINE PARALLEL TO GROUND AT 6.51 m (21.36 ft), SHOCK-ABSORBER RELAXED, CLEARANCE OF MAIN LANDING GEAR WHEELS: 0.23 m (0.75 ft) (STANDARD TIRES 01), CLEARANCE OF NOSE LANDING GEAR WHEELS: 1.51 m (4.95 ft) (STANDARD TIRES 01)	4.37 m (14.34 ft)	5.81 m (19.06 ft)		6.42 m (21.06 ft)

NOTE:

01 STANDARD TIRES: NOSE LANDING GEAR = 1 050 x 395 R16
MAIN LANDING GEAR = 1 400 x 530 R23

F_AC_021400_1_0050401_01_01

Jacking for Maintenance
Jacking Dimensions
FIGURE-2-14-0-991-005-D01

****ON A/C A330-900**

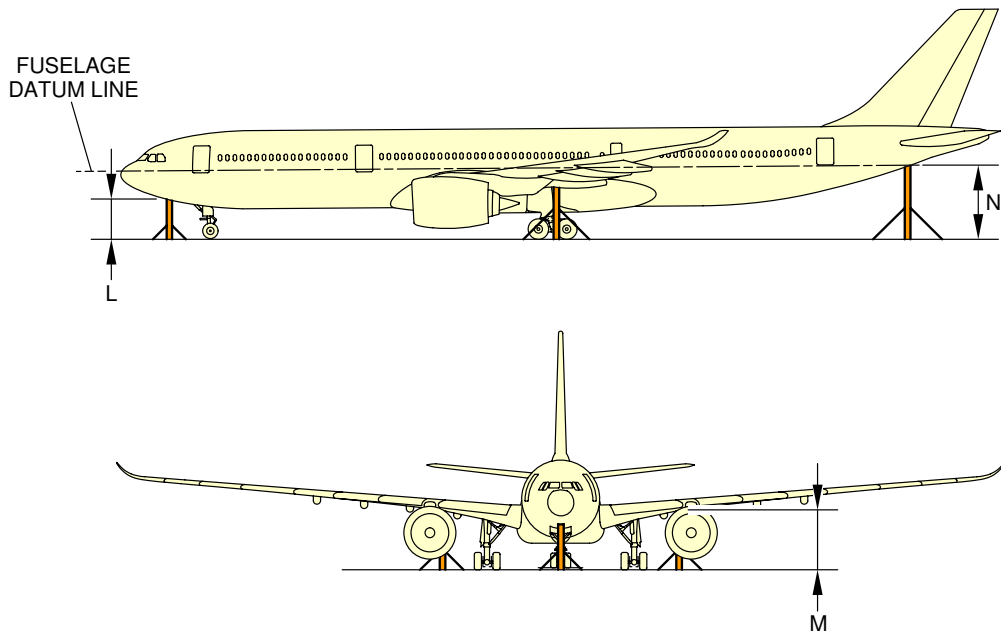

	L	M		N
AIRCRAFT ON WHEELS WITH STANDARD TIRES 01 , MAX. JACK WEIGHT 152 000 kg (335 103 lb)	2.65 m (8.69 ft)	4.59 m (15.06 ft)		5.66 m (18.57 ft)
AIRCRAFT ON WHEELS WITH STANDARD TIRES 01 , OEW 135 093 kg (297 829 lb)	2.63 m (8.63 ft)	4.64 m (15.22 ft)		5.79 m (19.00 ft)
AIRCRAFT ON WHEELS, SHOCK ABSORBER DEFLATED AND FLAT TIRES (RH)	2.68 m (8.79 ft)	(LH) 4.70 m (15.42 ft)	(RH) 3.98 m (13.06 ft)	5.16 m (16.93 ft)
AIRCRAFT ON JACKS, FUSELAGE DATUM LINE PARALLEL TO GROUND AT 6.51 m (21.36 ft), SHOCK-ABSORBER RELAXED, CLEARANCE OF MAIN LANDING GEAR WHEELS: 0.24 m (0.79 ft) (STANDARD TIRES 01), CLEARANCE OF NOSE LANDING GEAR WHEELS: 1.50 m (4.92 ft) (STANDARD TIRES 01)	4.37 m (14.34 ft)	5.81 m (19.06 ft)		6.42 m (21.06 ft)

NOTE:

01 STANDARD TIRES: NOSE LANDING GEAR = 1 050 x 395 R16
MAIN LANDING GEAR = 1 400 x 530 R23

F_AC_021400_1_0050501_01_01

Jacking for Maintenance
Jacking Dimensions
FIGURE-2-14-0-991-005-E01

2-14-1 Jacking of the Landing Gear

****ON A/C A330-200 A330-200F A330-300 A330-800 A330-900**

Jacking of the Landing Gear

1. General

Landing gear jacking will be required to lift the landing gear wheels off the ground.

NOTE : You can lift the aircraft at Maximum Ramp Weight (MRW).

NOTE : The load at each jacking position is the load required to give 25.4 mm (1 in) clearance between the ground and the tire.

2. Main Gear Jacking

The main gears are normally jacked up by placing a jack directly under the ball pad.

The ball spherical radius is 19 mm (0.75 in).

It is also possible to jack the main gear using a cantilever jack.

The reactions at each of the jacking points are shown in the table, see FIGURE 2-14-1-991-026-A FIGURE 2-14-1-991-026-B FIGURE 2-14-1-991-026-C FIGURE 2-14-1-991-026-D. These loads apply to all existing variants and weights of the concerned aircraft.

3. Nose Gear Jacking

For nose gear jacking, a 19 mm (0.75 in) radius ball pad is fitted under the lower end of the shock-absorber sliding tube. Jacking can be accomplished either by placing a jack directly under the ball pad, or using an adapter fitting provided with an identical ball pad.

The reactions at each of the jacking points are shown in the table, see FIGURE 2-14-1-991-026-A FIGURE 2-14-1-991-026-B FIGURE 2-14-1-991-026-C FIGURE 2-14-1-991-026-D. These loads apply to all existing variants and weights of the concerned aircraft.

**ON A/C A330-200 A330-200F A330-300 A330-800 A330-900

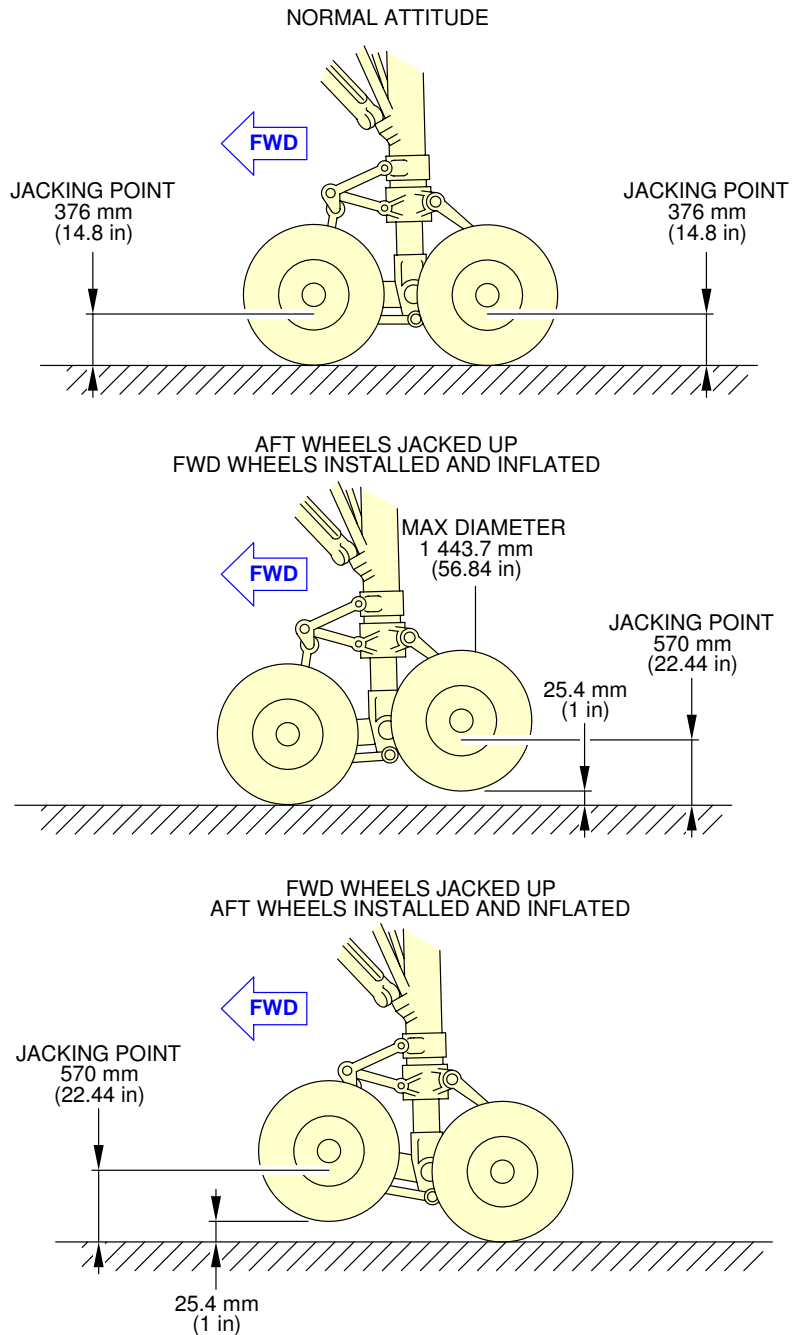

F_AC_021401_1_0010102_01_00

Jacking of the Landing Gear
MLG Jacking Point Heights (Sheet 1 of 3)
FIGURE-2-14-1-991-001-A01

****ON A/C A330-200 A330-200F A330-300 A330-800 A330-900**

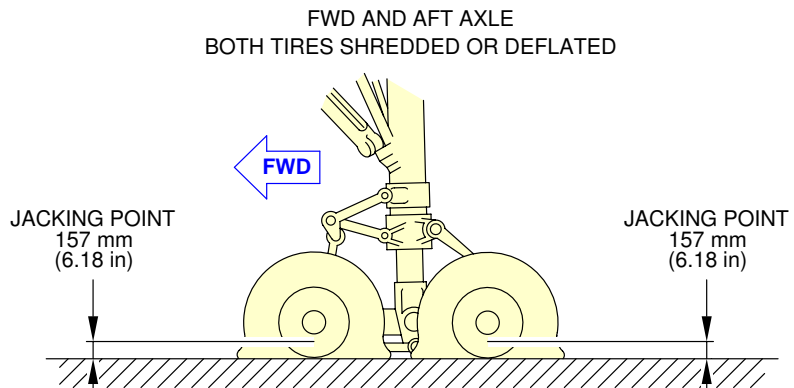
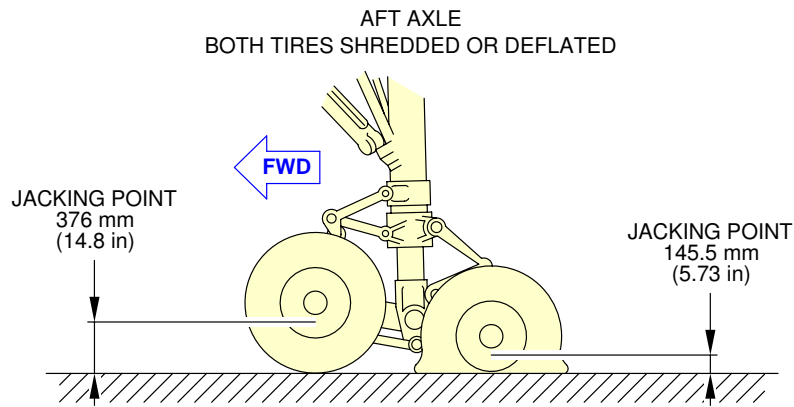
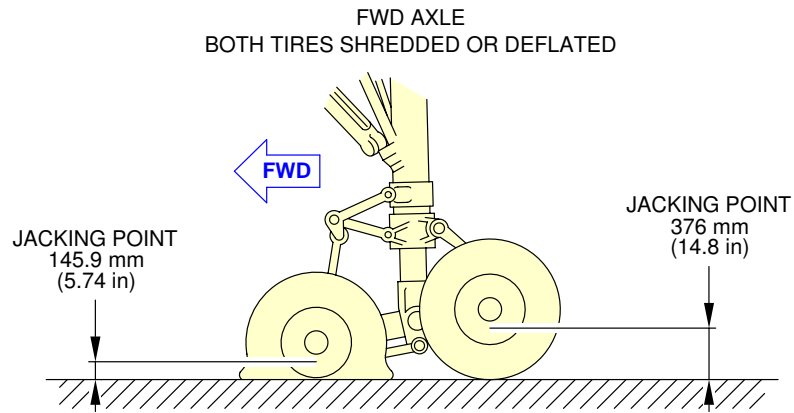

F_AC_021401_1_0010103_01_00

Jacking of the Landing Gear
MLG Jacking Point Heights (Sheet 2 of 3)
FIGURE-2-14-1-991-001-A01

****ON A/C A330-200 A330-200F A330-300 A330-800 A330-900**

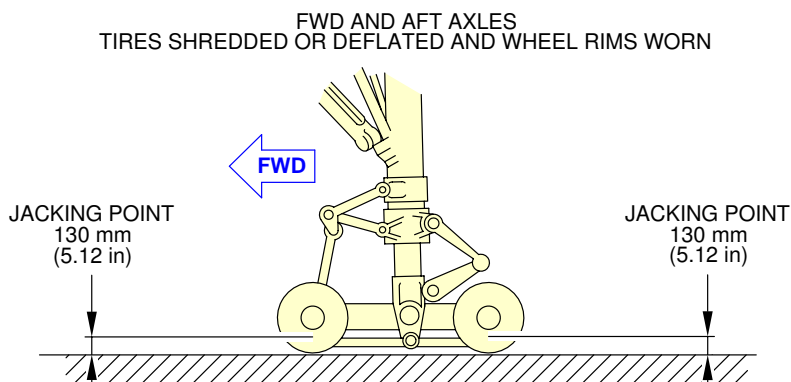
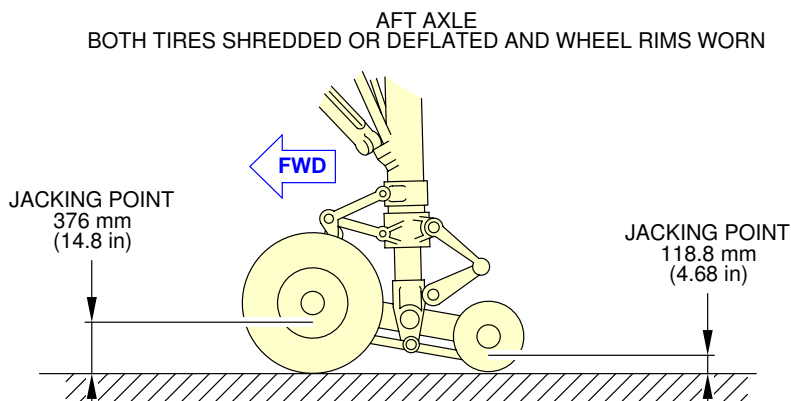
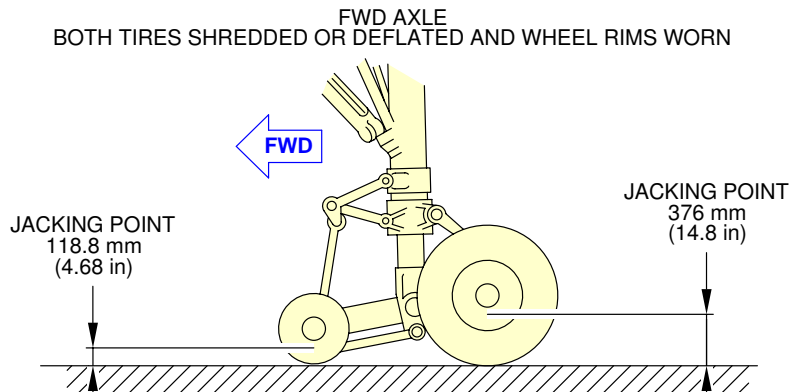

F_AC_021401_1_0010104_01_00

Jacking of the Landing Gear
MLG Jacking Point Heights (Sheet 3 of 3)
FIGURE-2-14-1-991-001-A01

****ON A/C A330-200 A330-200F A330-300 A330-800 A330-900**

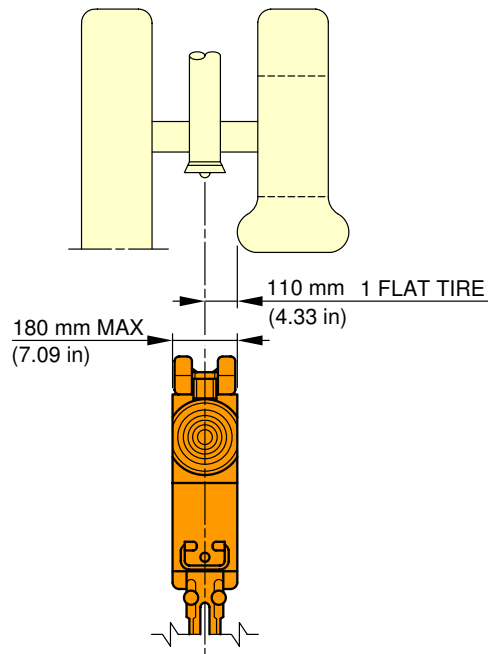
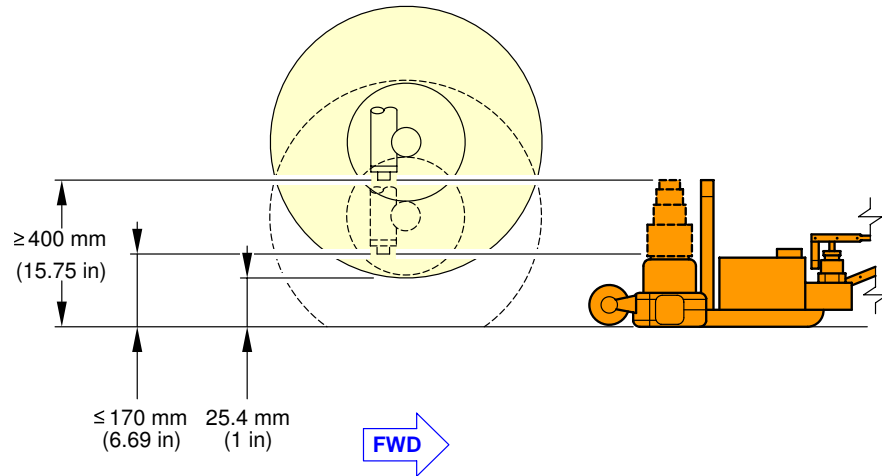

F_AC_021401_1_0020101_01_00

Jacking of the Landing Gear
Jacking of the NLG (Sheet 1 of 2)
FIGURE-2-14-1-991-002-A01

****ON A/C A330-200 A330-200F A330-300 A330-800 A330-900**

NORMAL ATTITUDE

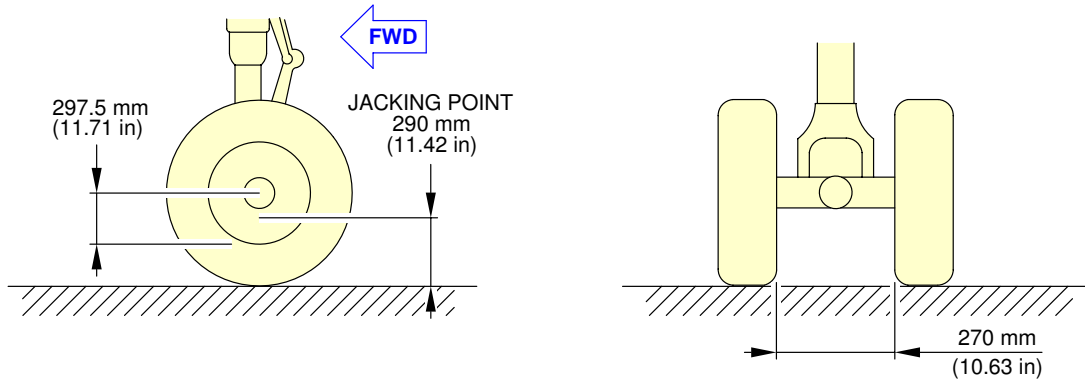

TWO TIRES DEFLATED OR SHREDDED

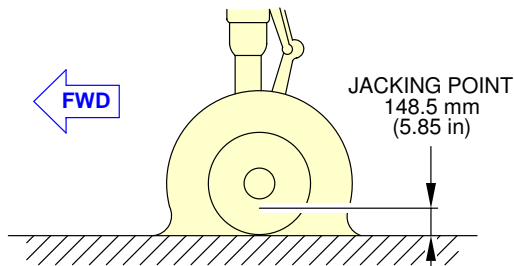

HEIGHT OF JACKING POINT TO GROUND TO CHANGE/REPLACE THE WHEEL ASSEMBLY

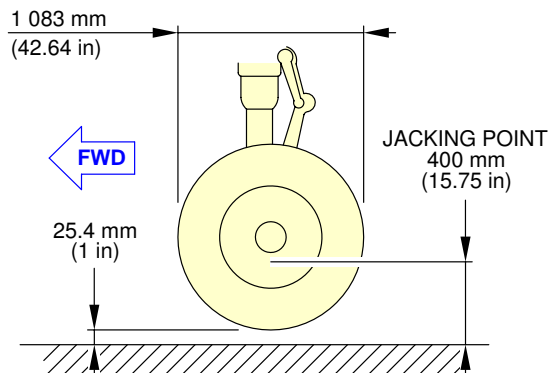

F_AC_021401_1_0020102_01_00

Jacking of the Landing Gear
 NLG Jacking Point Heights (Sheet 2 of 2)
 FIGURE-2-14-1-991-002-A01

****ON A/C A330-300**

A330-300 WV080	
MAXIMUM DESIGN TAXI WEIGHT (MTW)	238 900 kg (526 684 lb)
MAXIMUM DESIGN TAKE-OFF WEIGHT (MTOW)	238 000 kg (524 700 lb)
MAXIMUM LOAD VALUE TO BE APPLIED ON NLG JACKING POINT	24 900 kg (54 895 lb)
NUMBER OF JACKING POINTS ON ONE MLG	2
MAXIMUM LOAD VALUE TO BE APPLIED ON EACH MLG JACKING POINT	56 750 kg (125 112 lb)

F_AC_021401_1_0260101_01_00

Jacking of the Landing Gear
Maximum Load at Each Jacking Point
FIGURE-2-14-1-991-026-A01

****ON A/C A330-200**

A330-200 WV062	
MAXIMUM DESIGN TAXI WEIGHT (MTW)	238 900 kg (526 684 lb)
MAXIMUM DESIGN TAKE-OFF WEIGHT (MTOW)	238 000 kg (524 700 lb)
MAXIMUM LOAD VALUE TO BE APPLIED ON NLG JACKING POINT	26 000 kg (57 320 lb)
NUMBER OF JACKING POINTS ON ONE MLG	2
MAXIMUM LOAD VALUE TO BE APPLIED ON EACH MLG JACKING POINT	55 000 kg (121 254 lb)

F_AC_021401_1_0260201_01_00

Jacking of the Landing Gear
Maximum Load at Each Jacking Point
FIGURE-2-14-1-991-026-B01

****ON A/C A330-900**

A330-900 WV901	
MAXIMUM DESIGN TAXI WEIGHT (MTW)	242 900 kg (535 503 lb)
MAXIMUM DESIGN TAKE-OFF WEIGHT (MTOW)	242 000 kg (533 519 lb)
MAXIMUM LOAD VALUE TO BE APPLIED ON NLG JACKING POINT	23 569 kg (51 961 lb)
NUMBER OF JACKING POINTS ON ONE MLG	2
MAXIMUM LOAD VALUE TO BE APPLIED ON EACH MLG JACKING POINT	57 107 kg (125 899 lb)

F_AC_021401_1_0260301_01_01

Jacking of the Landing Gear
Maximum Load at Each Jacking Point
FIGURE-2-14-1-991-026-C01

****ON A/C A330-800**

A330-800 WV801	
MAXIMUM DESIGN TAXI WEIGHT (MTW)	242 900 kg (535 503 lb)
MAXIMUM DESIGN TAKE-OFF WEIGHT (MTOW)	242 000 kg (533 519 lb)
MAXIMUM LOAD VALUE TO BE APPLIED ON NLG JACKING POINT	21 565 kg (47 543 lb)
NUMBER OF JACKING POINTS ON ONE MLG	2
MAXIMUM LOAD VALUE TO BE APPLIED ON EACH MLG JACKING POINT	56 894 kg (125 430 lb)

F_AC_021401_1_0260401_01_01

Jacking of the Landing Gear
Maximum Load at Each Jacking Point
FIGURE-2-14-1-991-026-D01

2-14-2 Support of Aircraft

****ON A/C A330-200 A330-200F A330-300 A330-800 A330-900**

Support of Aircraft

1. Support of Aircraft

When it is necessary to support the aircraft in order to relieve the loads on the structure for the accomplishment of modifications or major work, it is advisable to provide adapters under the wings and the fuselage for an alternative means of lifting.

The aircraft must not be lifted or supported by the wings or fuselage alone. It is important to support the aircraft fuselage and wings at the same time to prevent structural damage.

A. Shoring Cradles

Shoring cradles are used when it is necessary to stress-jack the aircraft to carry out maintenance and repair work. These are used to oppose the deflections of the wings and reduce the stresses to an acceptable level at the area of maintenance and repair.

The shoring cradles, each with two adjustable pads, 152.4 mm (6 in) square, are positioned at four locations under each wing.

The adjustable pads are faced with thin rubber and are in contact with the wing profile at the datum intersections of the ribs and the front and rear spars (F/S and R/S).

**ON A/C A330-200 A330-800

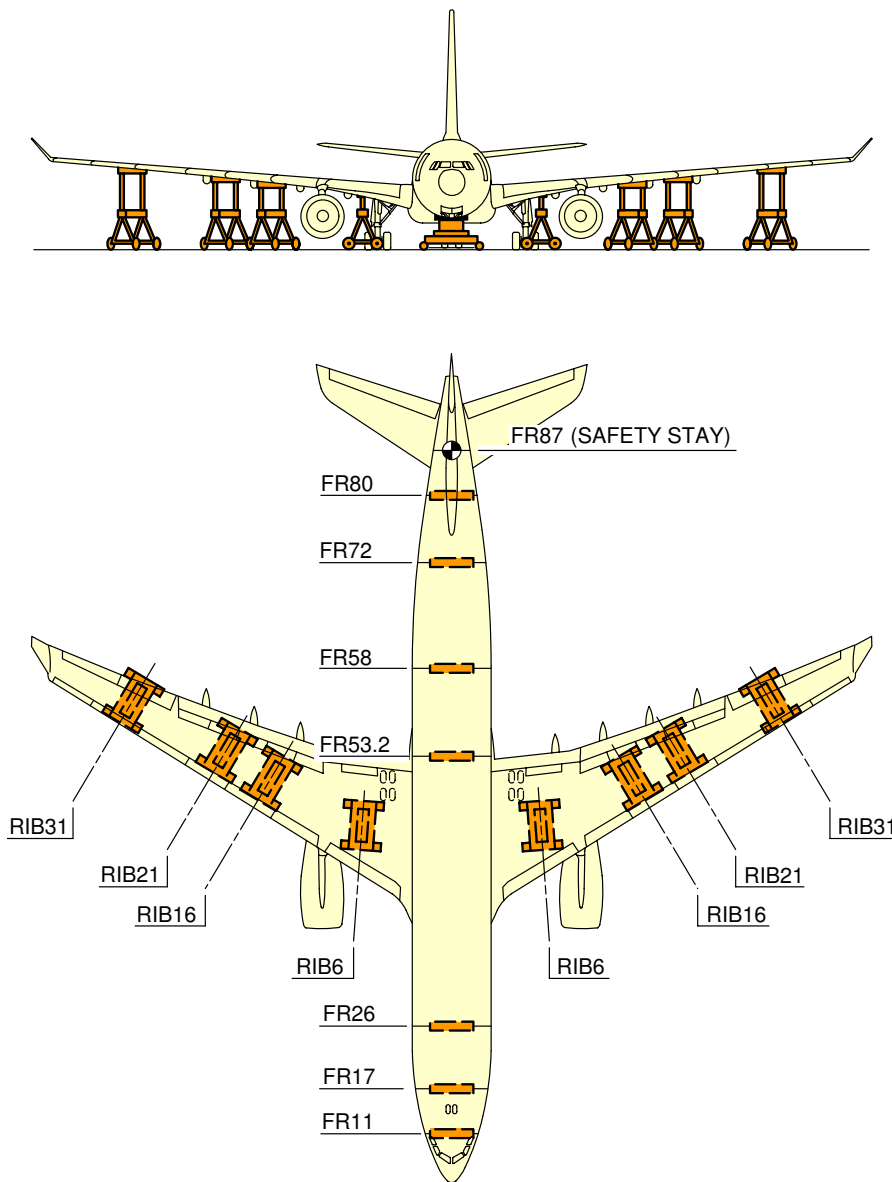

NOTE:
THE SHORING CRADLE MUST BE INSTALLED AT THE EXACT LOCATION OF THE FRAME.

F_AC_021402_1_0010101_01_00

Support of Aircraft
Location of Shoring Cradles (Sheet 1 of 2)
FIGURE-2-14-2-991-001-A01

**ON A/C A330-200 A330-800

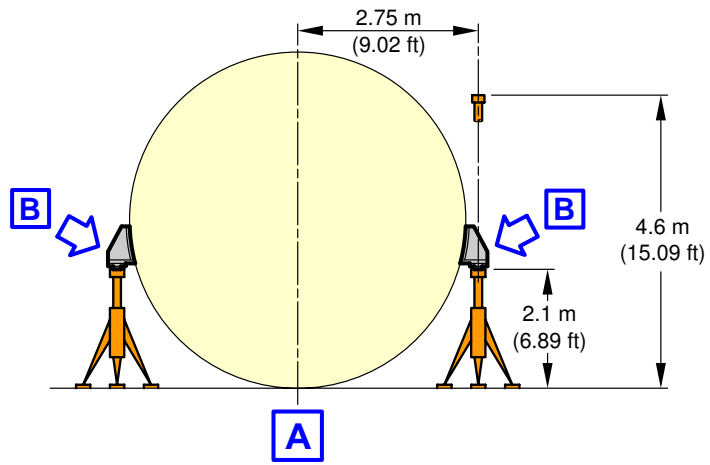
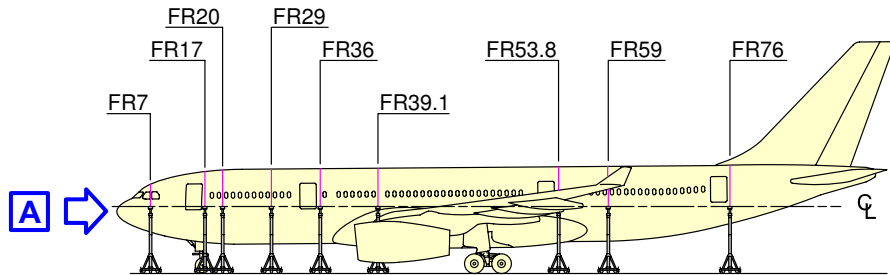

EXAMPLE

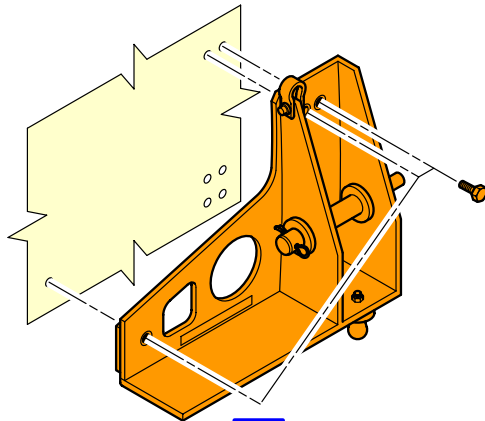

B
FWD
LH SHOWN
RH SYMMETRICAL

F_AC_021402_1_0010102_01_00

Support of Aircraft
Location of Auxiliary Jacking Points (Sheet 2 of 2)
FIGURE-2-14-2-991-001-A01

**ON A/C A330-300 A330-900

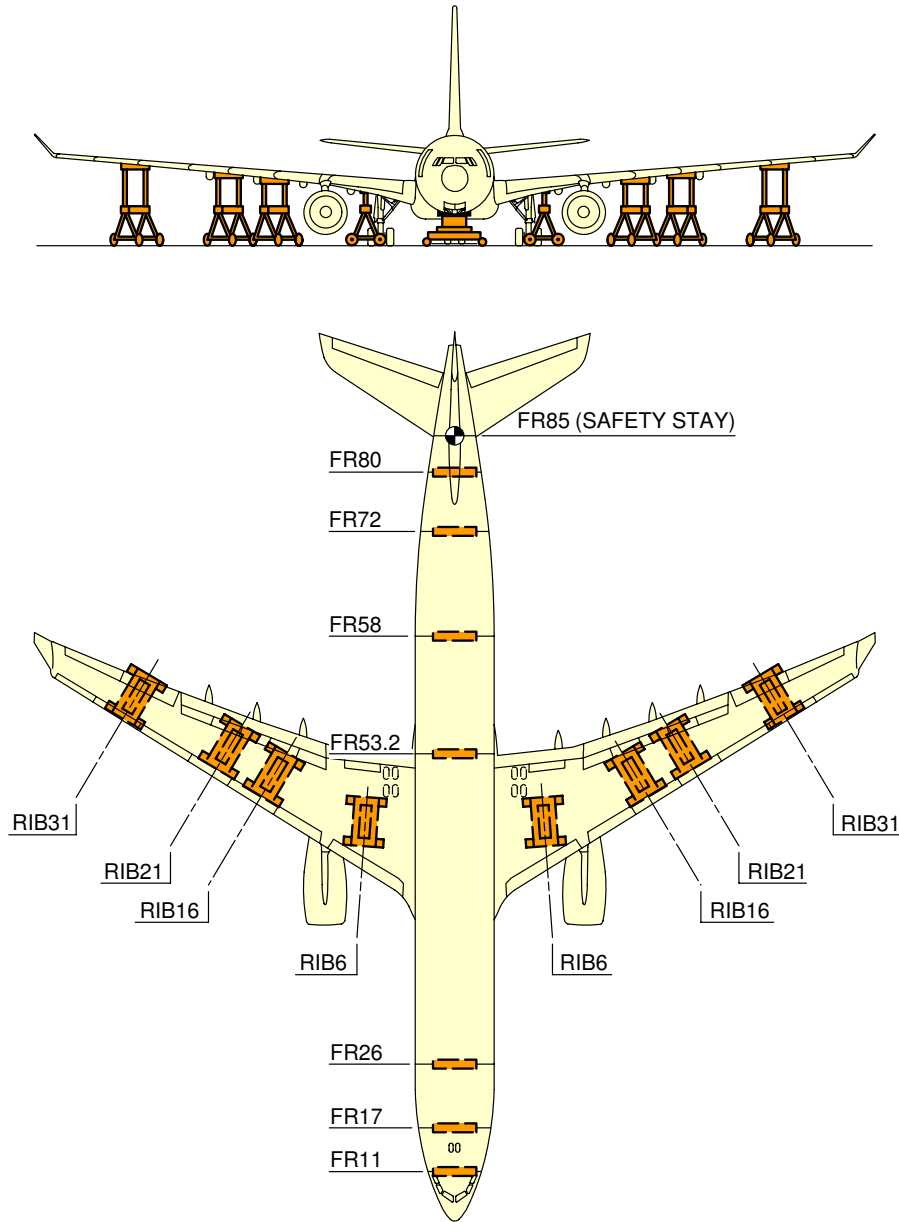

NOTE:

THE SHORING CRADLE MUST BE INSTALLED AT THE EXACT LOCATION OF THE FRAME.

F_AC_021402_1_0010201_01_00

Support of Aircraft
Location of Shoring Cradles (Sheet 1 of 2)
FIGURE-2-14-2-991-001-B01

**ON A/C A330-300 A330-900

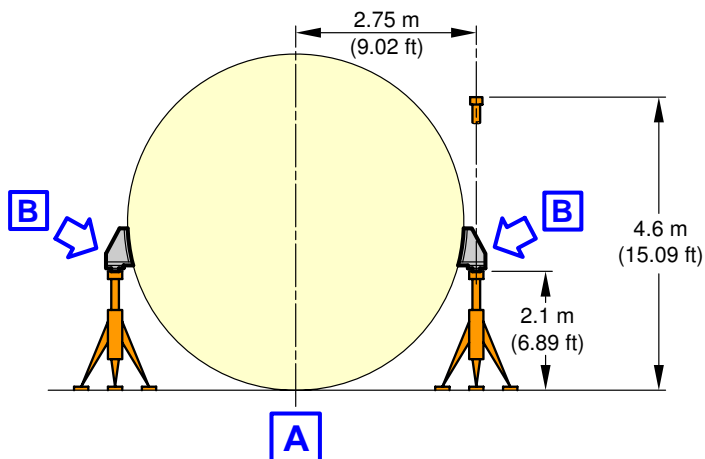
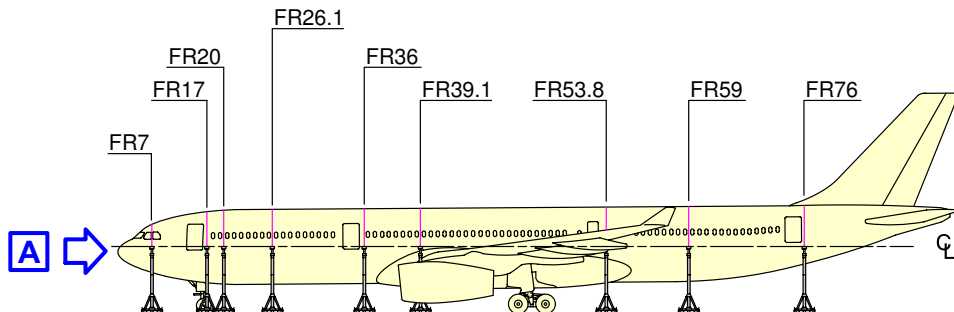

EXAMPLE

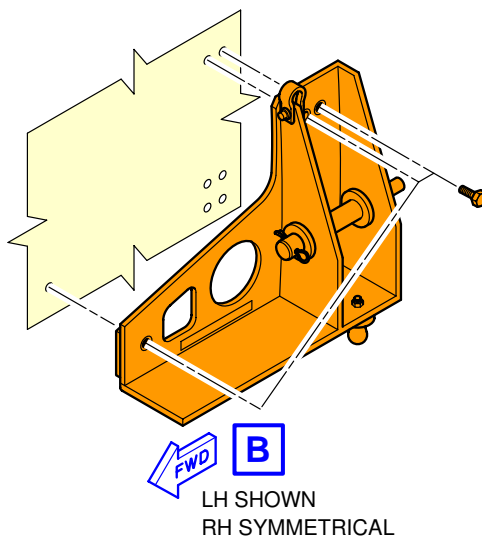

F_AC_021402_1_0010202_01_00

Support of Aircraft
 Location of Auxiliary Jacking Points (Sheet 2 of 2)
 FIGURE-2-14-2-991-001-B01

**ON A/C A330-200F

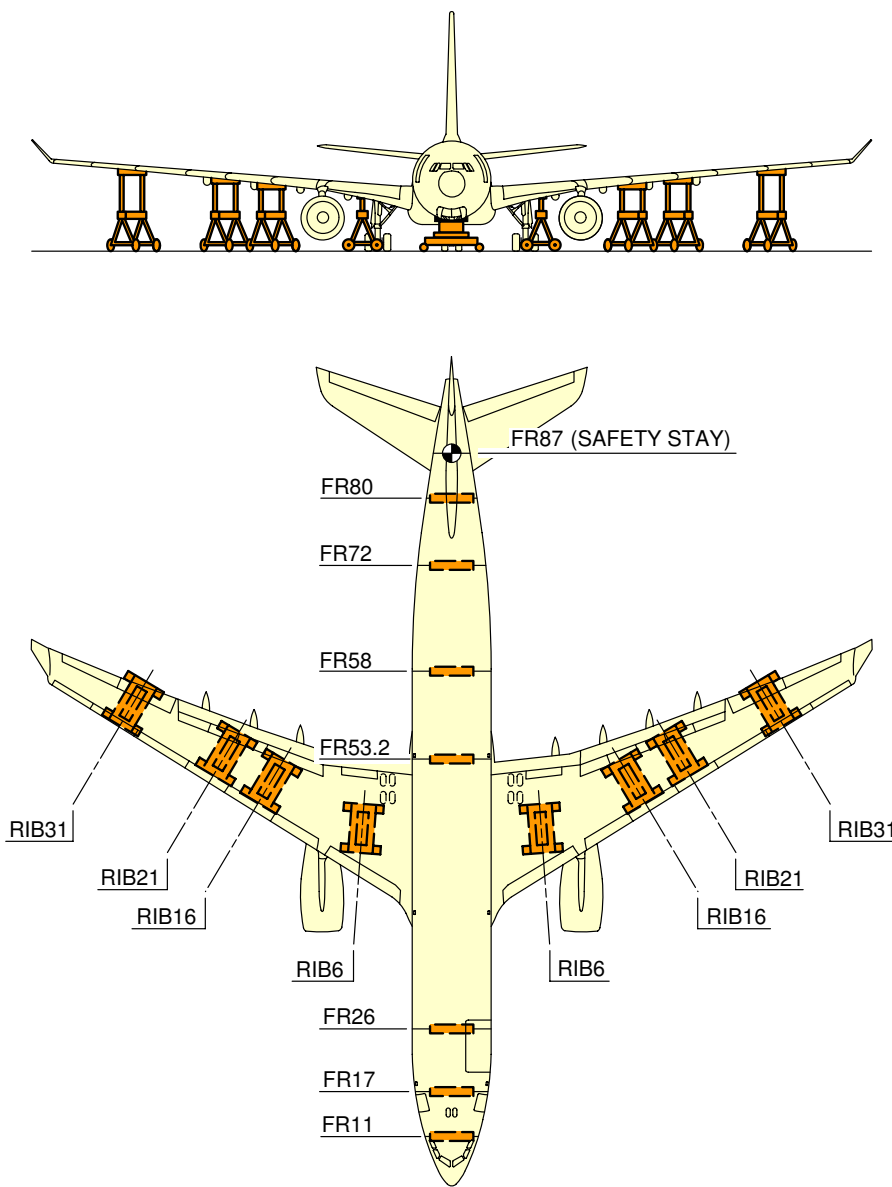

NOTE:

THE SHORING CRADLE MUST BE INSTALLED AT THE EXACT LOCATION OF THE FRAME.

F_AC_021402_1_0010301_01_00

Support of Aircraft
Location of Shoring Cradles (Sheet 1 of 2)
FIGURE-2-14-2-991-001-C01

**ON A/C A330-200F

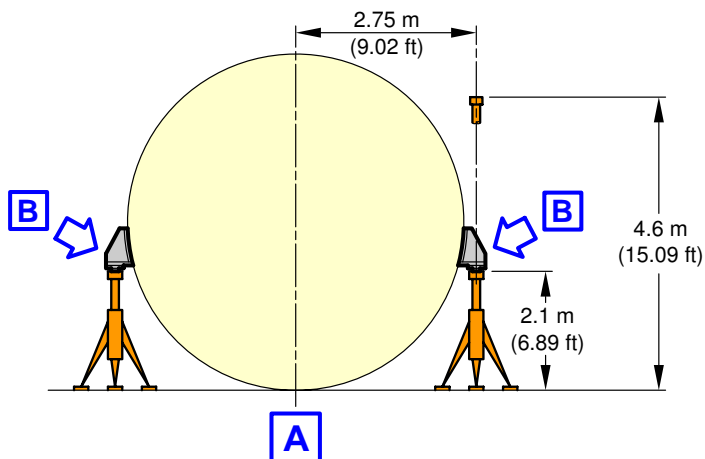
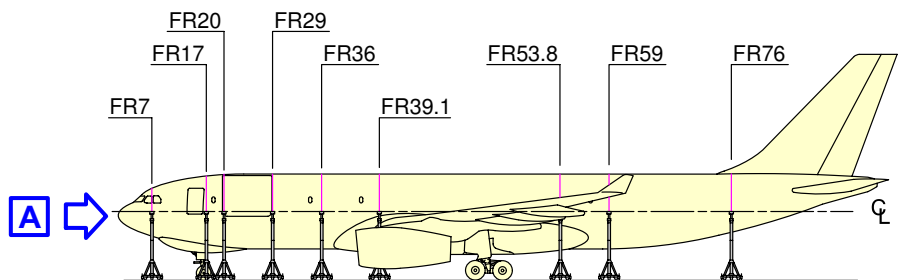

EXAMPLE

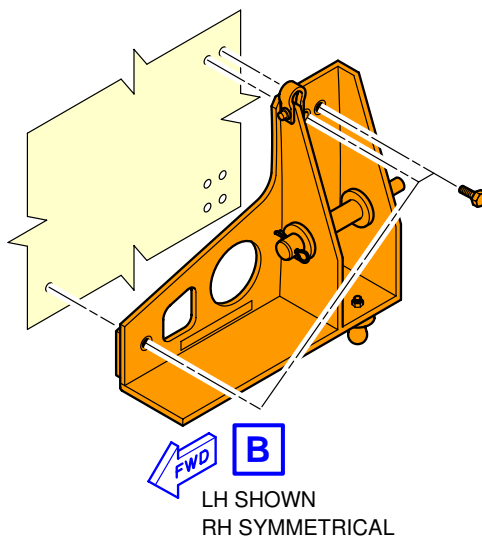

F_AC_021402_1_0010302_01_00

Support of Aircraft
Location of Auxiliary Jacking Points (Sheet 2 of 2)
FIGURE-2-14-2-991-001-C01

AIRCRAFT PERFORMANCE

3-1-0 General Information

****ON A/C A330-200 A330-200F A330-300 A330-800 A330-900**General Information

1. Standard day temperatures for the altitude shown are tabulated below :

Standard day temperatures for the altitude			
Altitude		Standard Day Temperature	
FEET	METERS	°F	°C
0	0	59.0	15.0
2000	610	51.9	11.1
4000	1220	44.7	7.1
6000	1830	37.6	3.1
8000	2440	30.5	-0.8



3-2-1 Payload / Range - ISA Conditions

****ON A/C A330-200 A330-200F A330-300 A330-900**

Payload / Range - ISA Conditions

1. This section gives the payload / range at ISA conditions.

**ON A/C A330-200

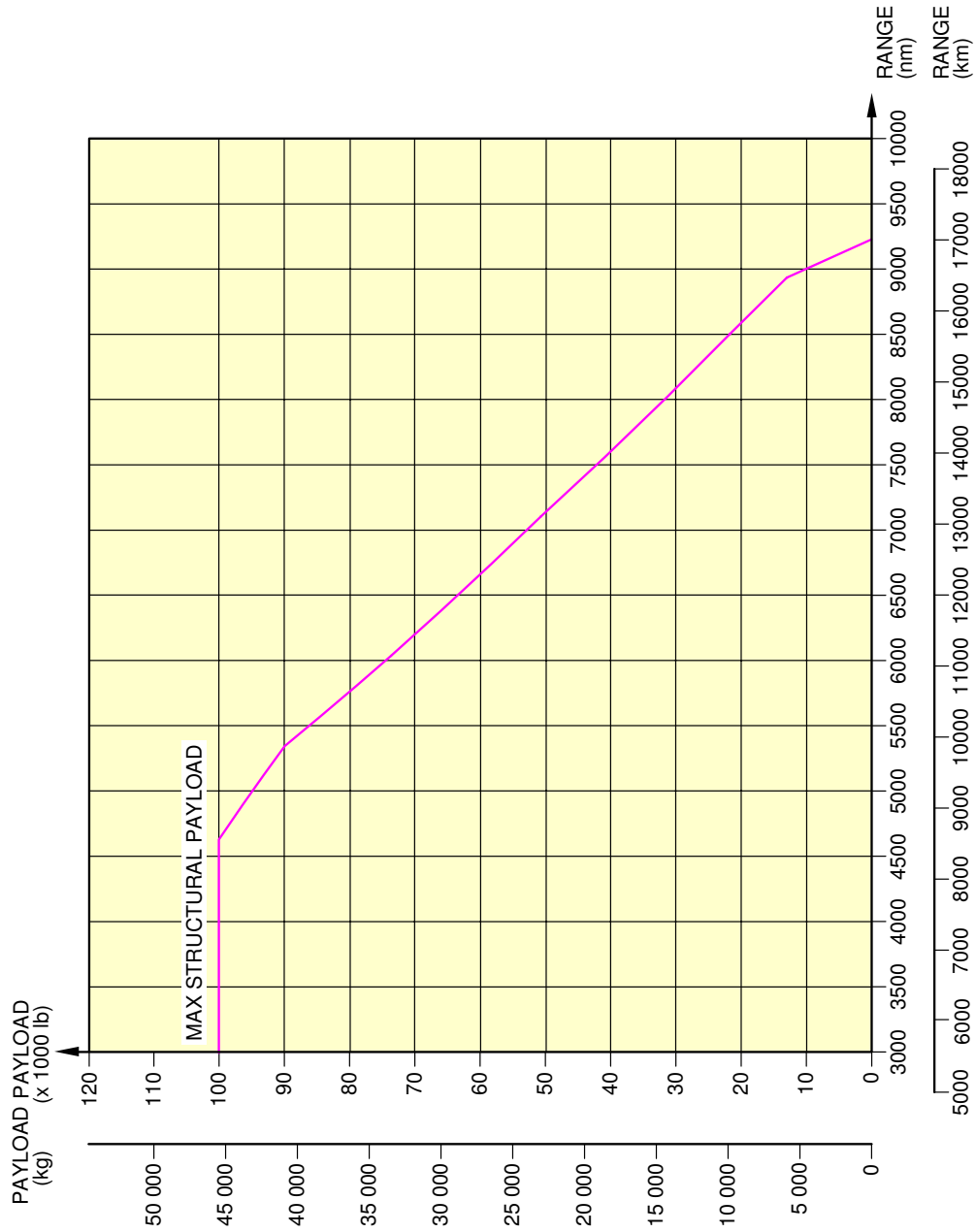

NOTE : THESE CURVES ARE GIVEN FOR INFORMATION ONLY
 THE APPROVED VALUES ARE STATED IN THE "OPERATING
 MANUALS" SPECIFIC TO THE AIRLINE OPERATING THE AIRCRAFT.
 MAX ZERO FUEL WEIGHT : 170 000 kg
 MAX TAKE-OFF WEIGHT : 242 000 kg

F_AC_030201_1_0010101_01_03

Payload / Range - ISA Conditions
 PW 4000 Series Engine
 FIGURE-3-2-1-991-001-A01

**ON A/C A330-200

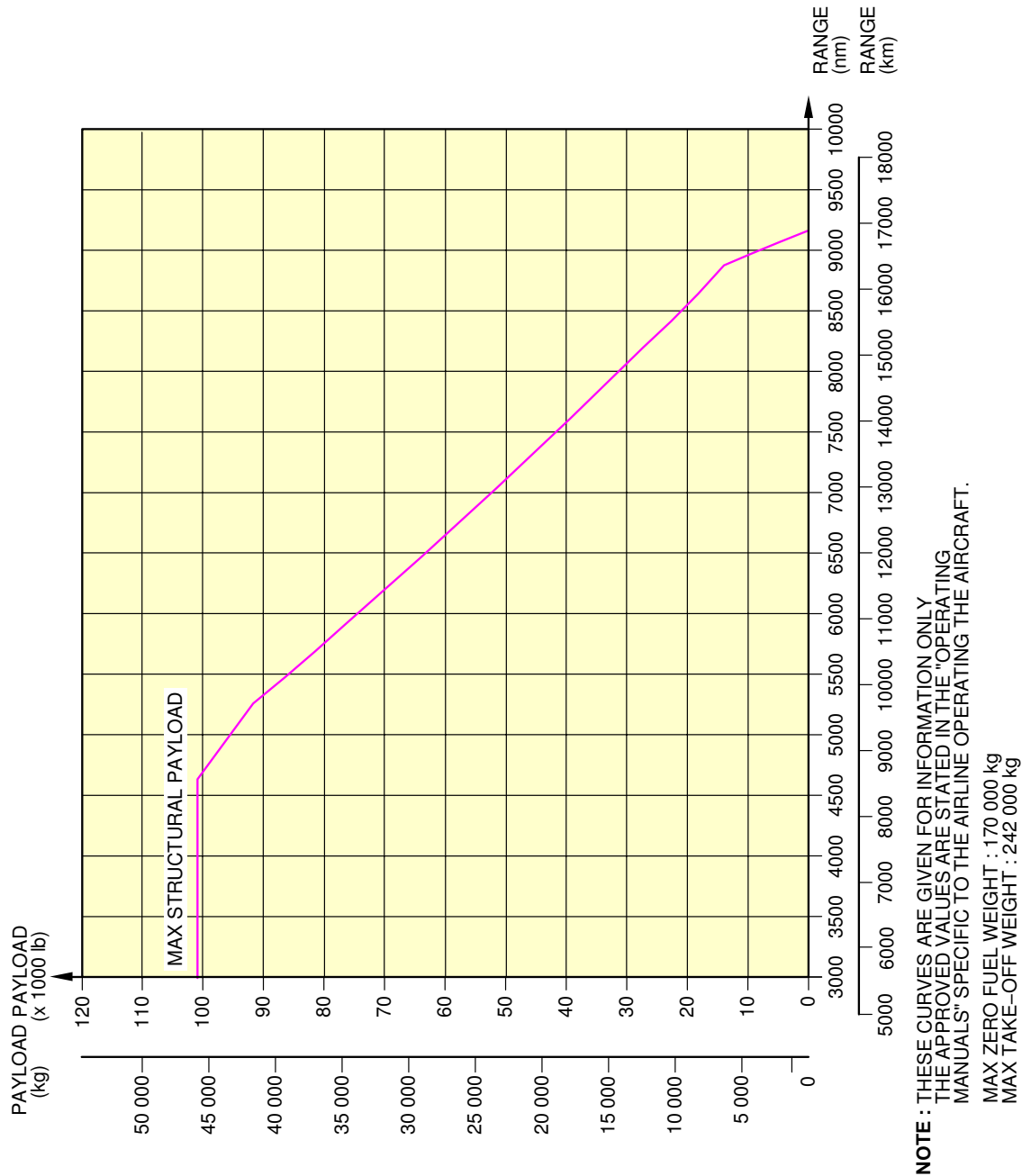

F_AC_030201_1_0020101_01_03

Payload / Range - ISA Conditions
 RR TRENT 700 Series Engine
 FIGURE-3-2-1-991-002-A01

**ON A/C A330-200

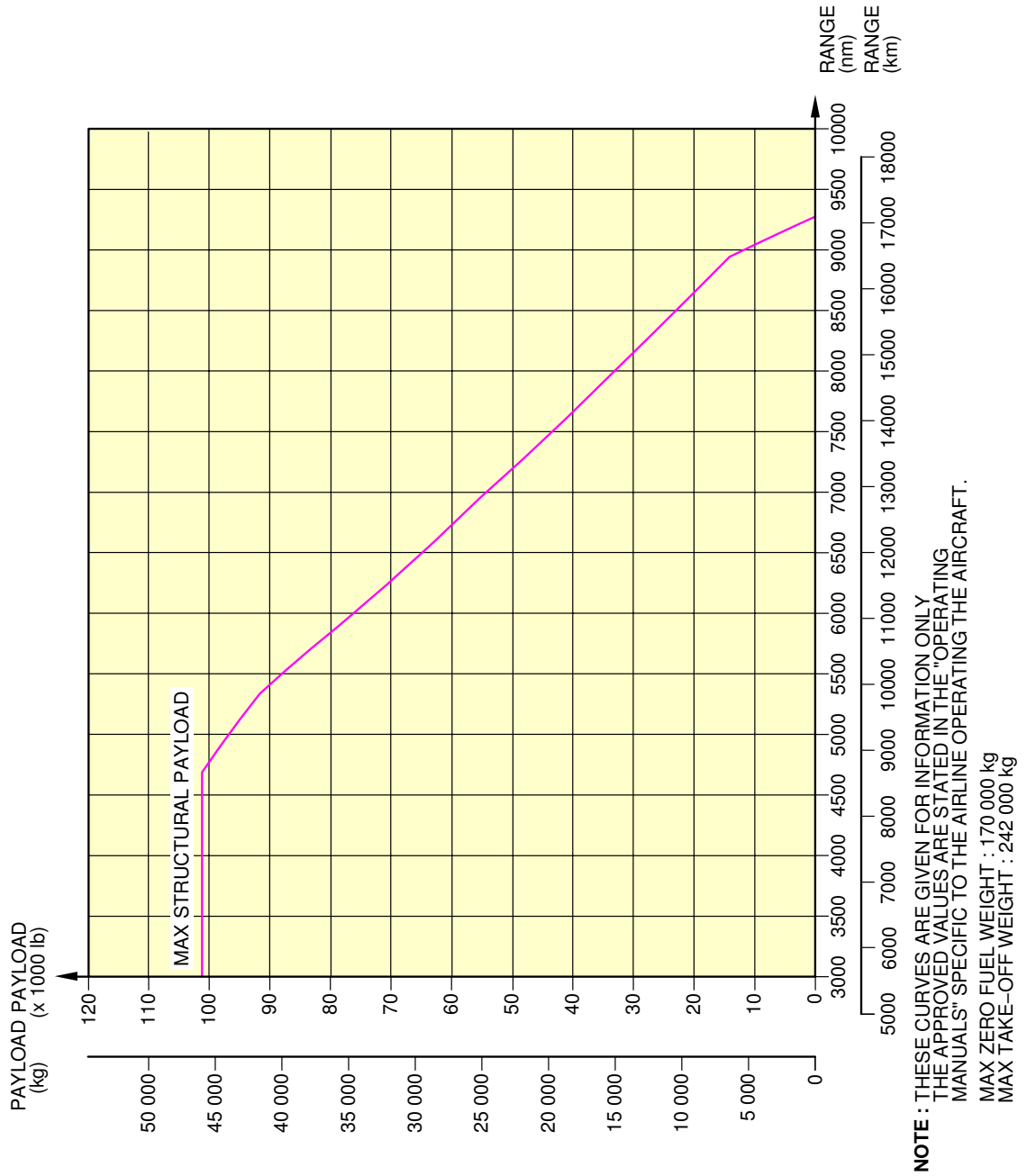

F_AC_030201_1_0030101_01_03

Payload / Range - ISA Conditions
 GE CF6-80E1 Series Engine
 FIGURE-3-2-1-991-003-A01

**ON A/C A330-200F

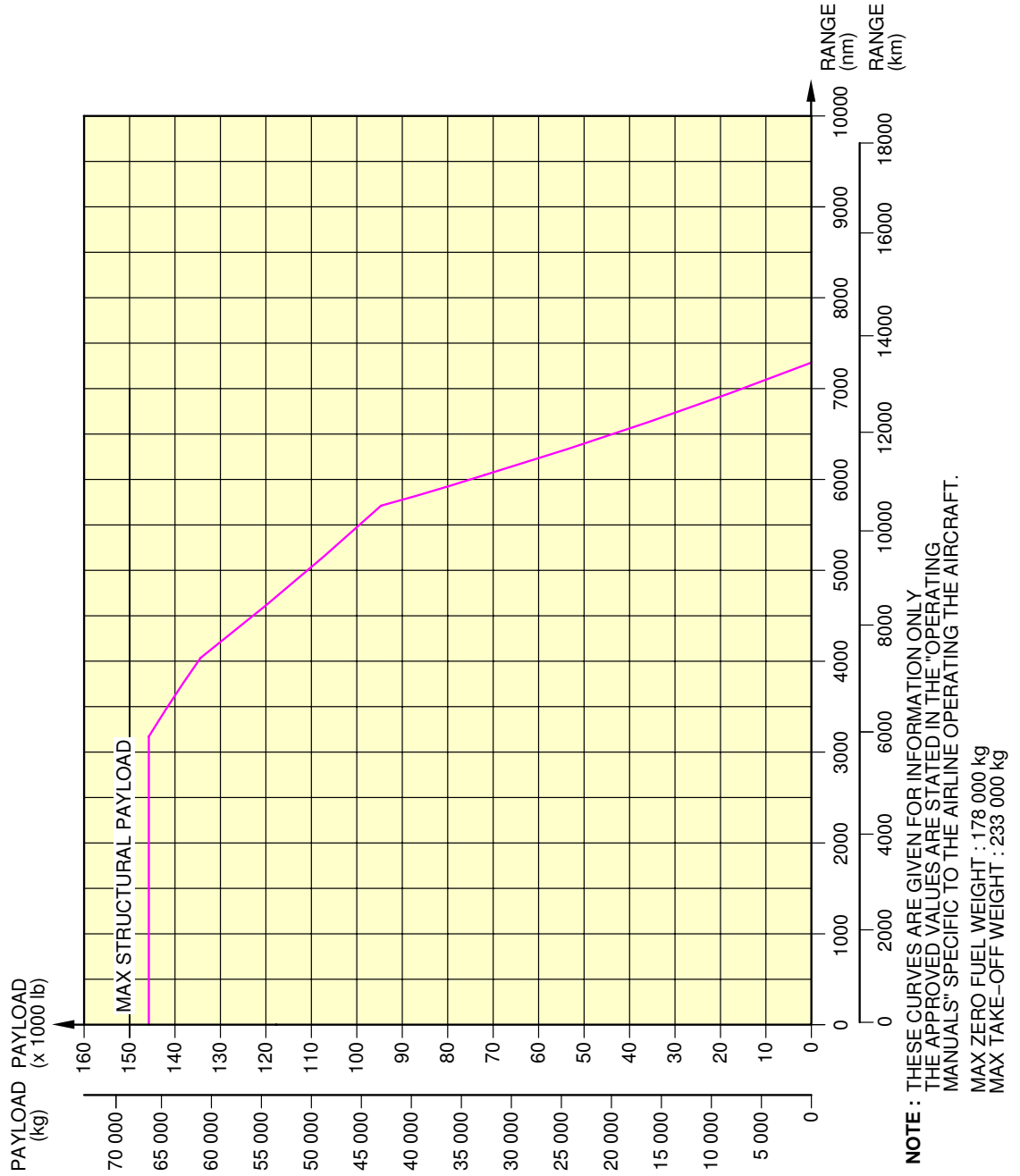

F_AC_030201_1_0290101_01_01

Payload / Range - ISA Conditions
 RR TRENT 700 Series Engine
 FIGURE-3-2-1-991-029-A01

**ON A/C A330-200F

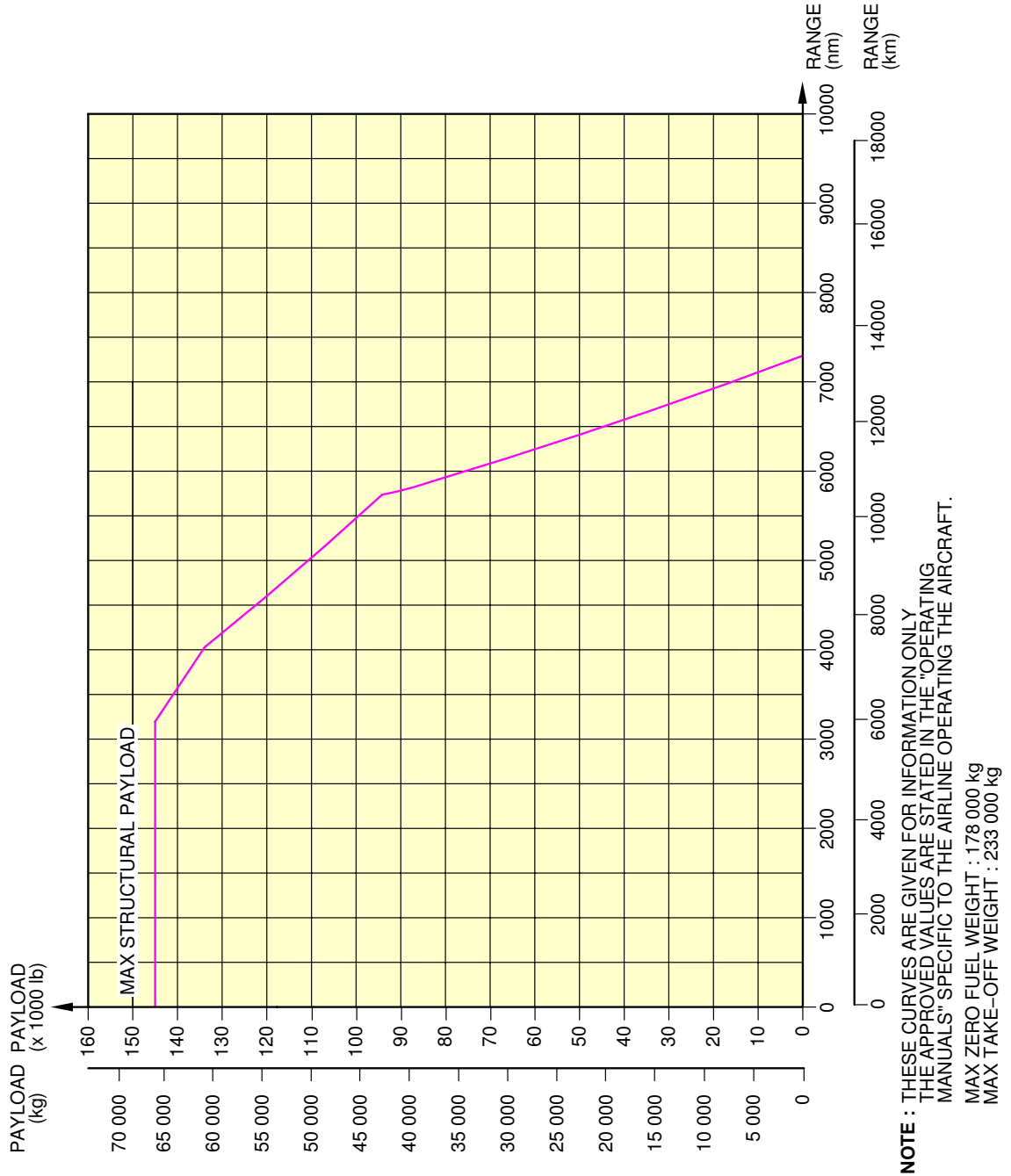

F_AC_030201_1_0310101_01_01

Payload / Range - ISA Conditions
 PW 4000 Series Engine
 FIGURE-3-2-1-991-031-A01

**ON A/C A330-300

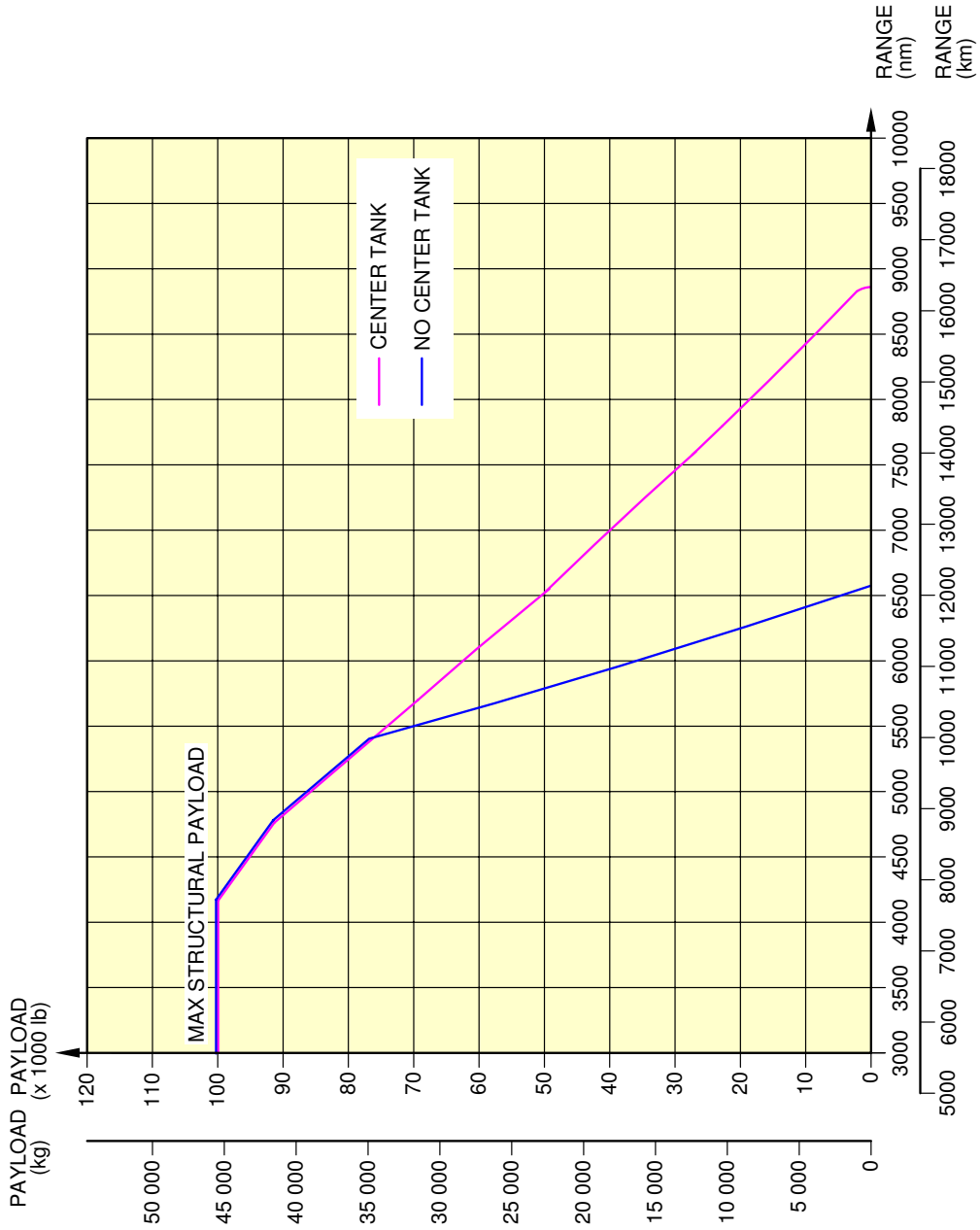

NOTE : THESE CURVES ARE GIVEN FOR INFORMATION ONLY
 THE APPROVED VALUES ARE STATED IN THE "OPERATING
 MANUALS" SPECIFIC TO THE AIRLINE OPERATING THE AIRCRAFT.
 MAX ZERO FUEL WEIGHT : 175 000 kg
 MAX TAKE-OFF WEIGHT : 242 000 kg

F_AC_030201_1_0040101_01_03

Payload / Range - ISA Conditions
 PW 4000 Series Engine
 FIGURE-3-2-1-991-004-A01

**ON A/C A330-300

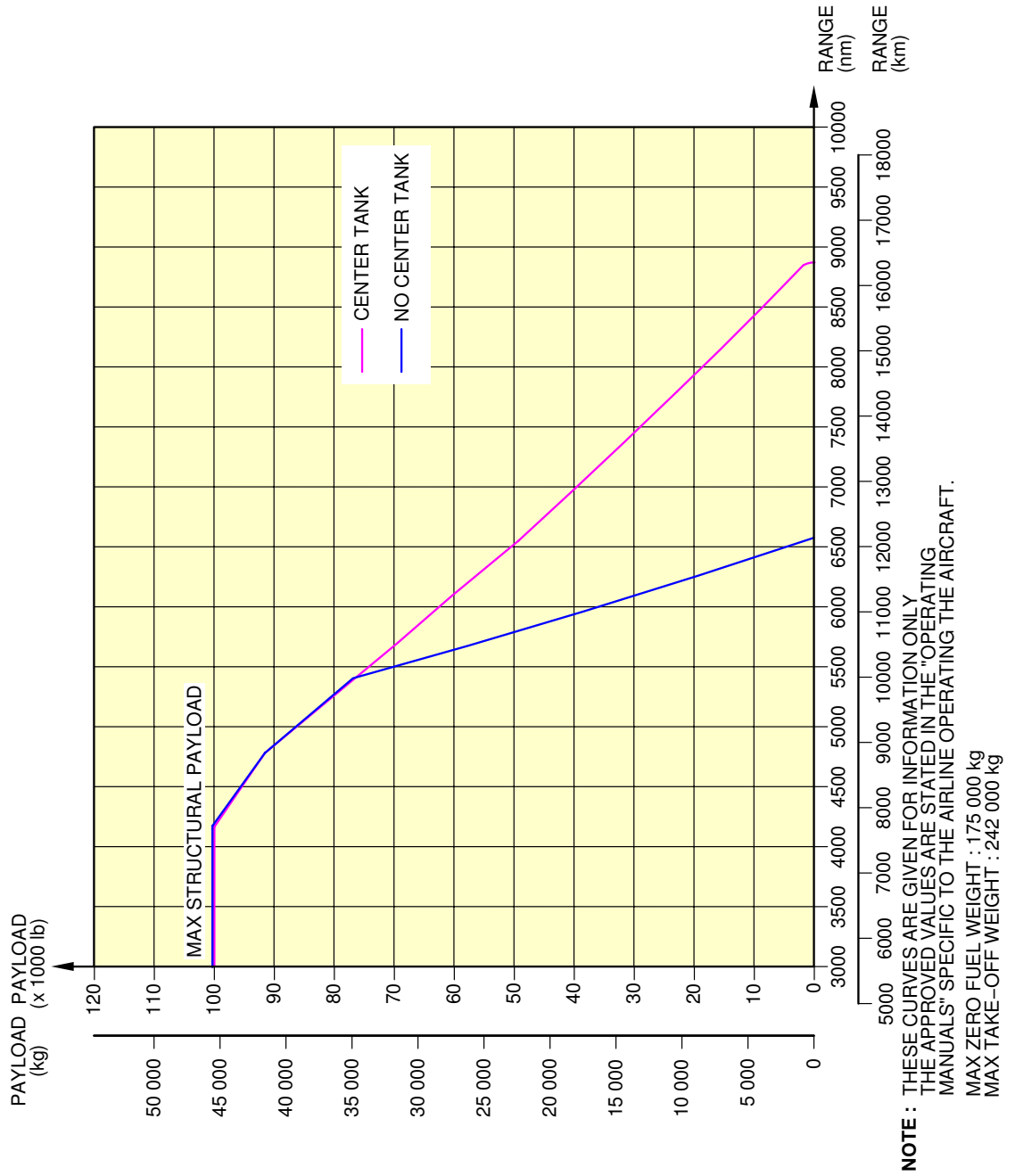

F_AC_030201_1_0050101_01_03

Payload / Range - ISA Conditions
 RR TRENT 700 Series Engine
 FIGURE-3-2-1-991-005-A01

****ON A/C A330-300**

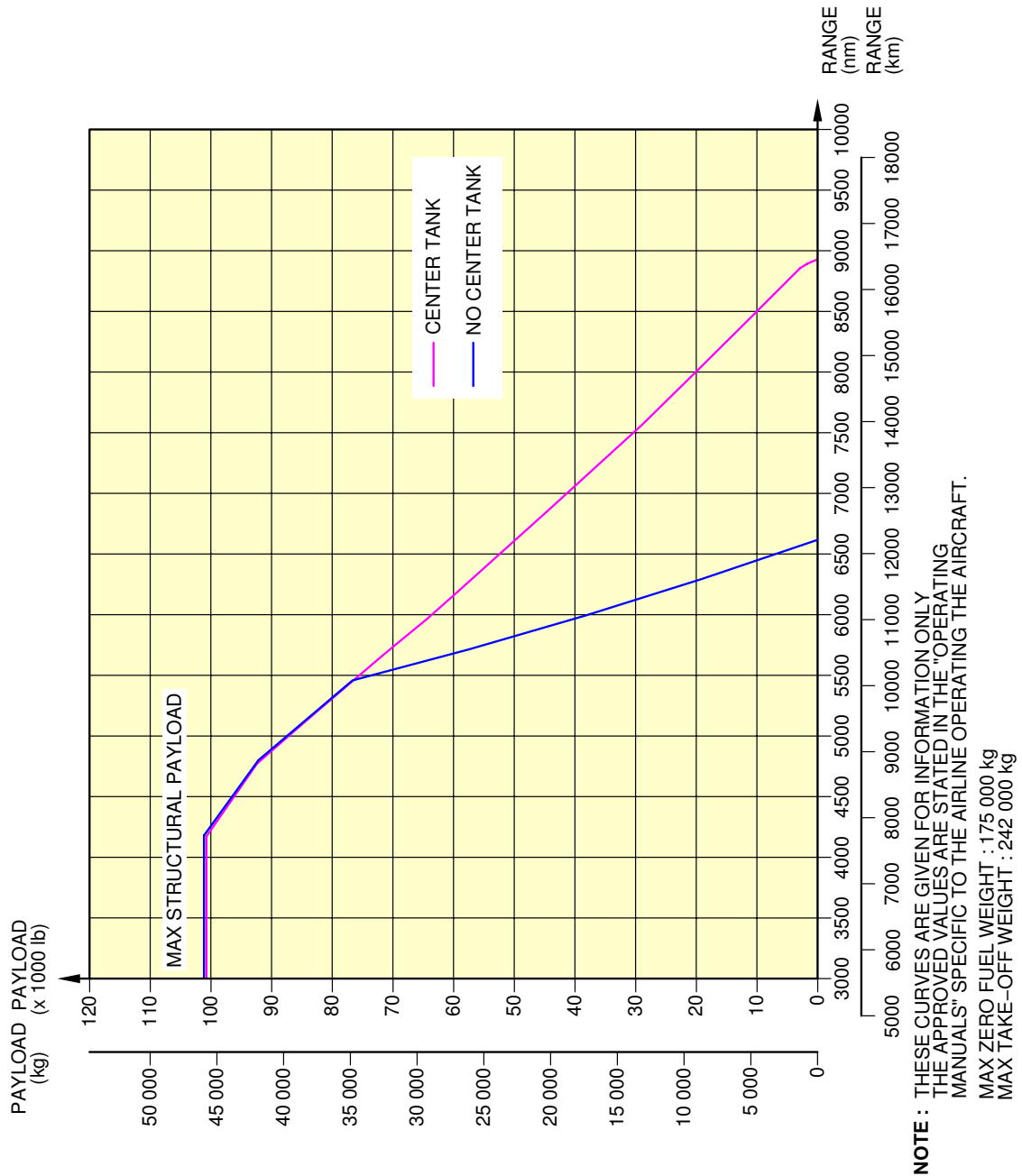

F_AC_030201_1_0060101_01_03

Payload / Range - ISA Conditions
 GE CF6-80E1 Series Engine
 FIGURE-3-2-1-991-006-A01

**ON A/C A330-900

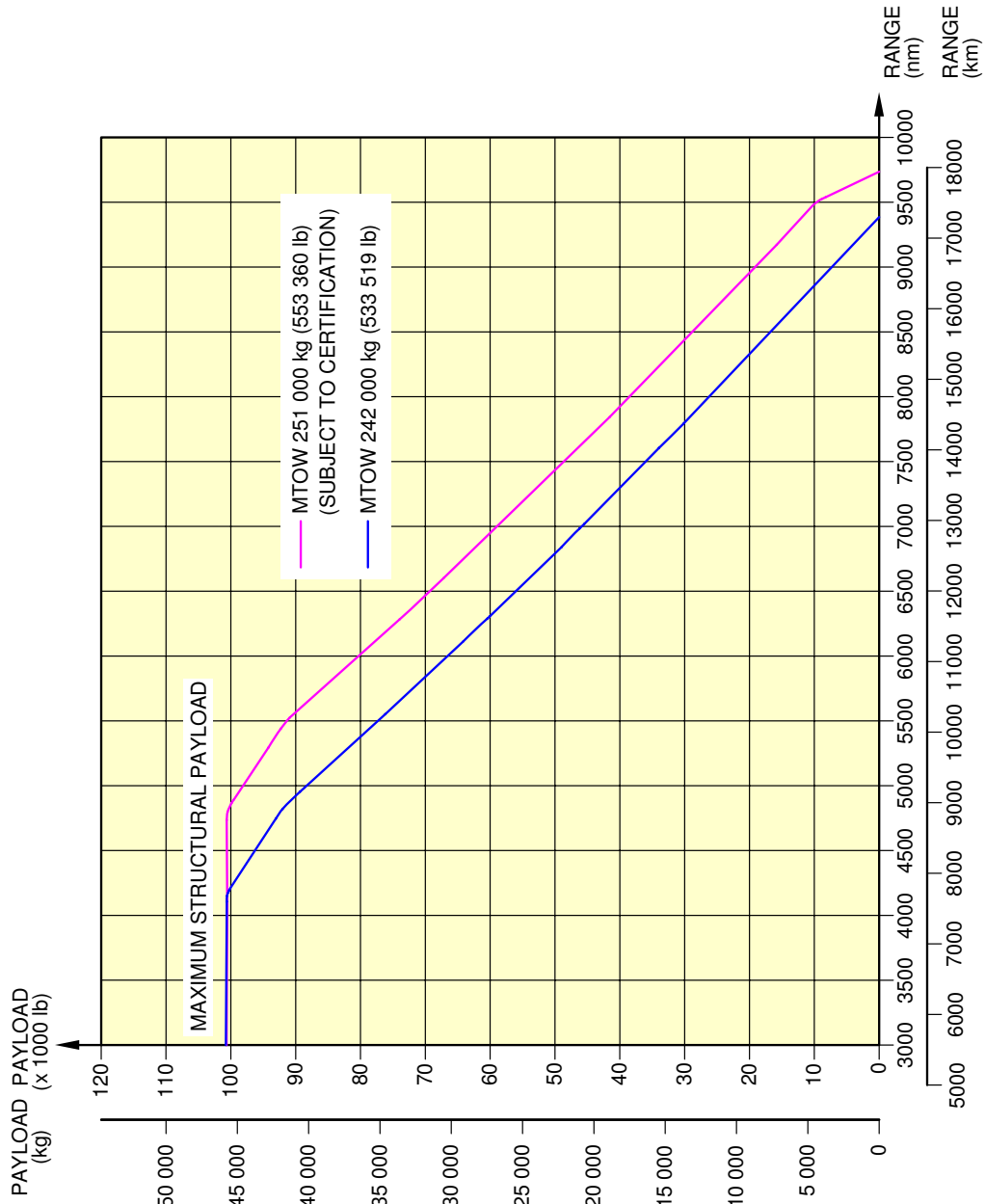

NOTE : THESE CURVES ARE GIVEN FOR INFORMATION ONLY. THE APPROVED VALUES ARE STATED IN THE "OPERATING MANUALS" SPECIFIC TO THE AIRLINE OPERATING THE AIRCRAFT.
 MAXIMUM ZERO FUEL WEIGHT : 181 000 kg (399 037 lb)

F_AC_030201_1_0330101_01_00

Payload / Range - ISA Conditions
 RR TRENT 7000 Series Engine
 FIGURE-3-2-1-991-033-A01



3-3-1 Take-Off Weight Limitation - ISA Conditions

****ON A/C A330-200 A330-200F A330-300 A330-900**

Take-Off Weight Limitation - ISA Conditions

1. This section gives the take-off weight limitation at ISA conditions.

**ON A/C A330-200

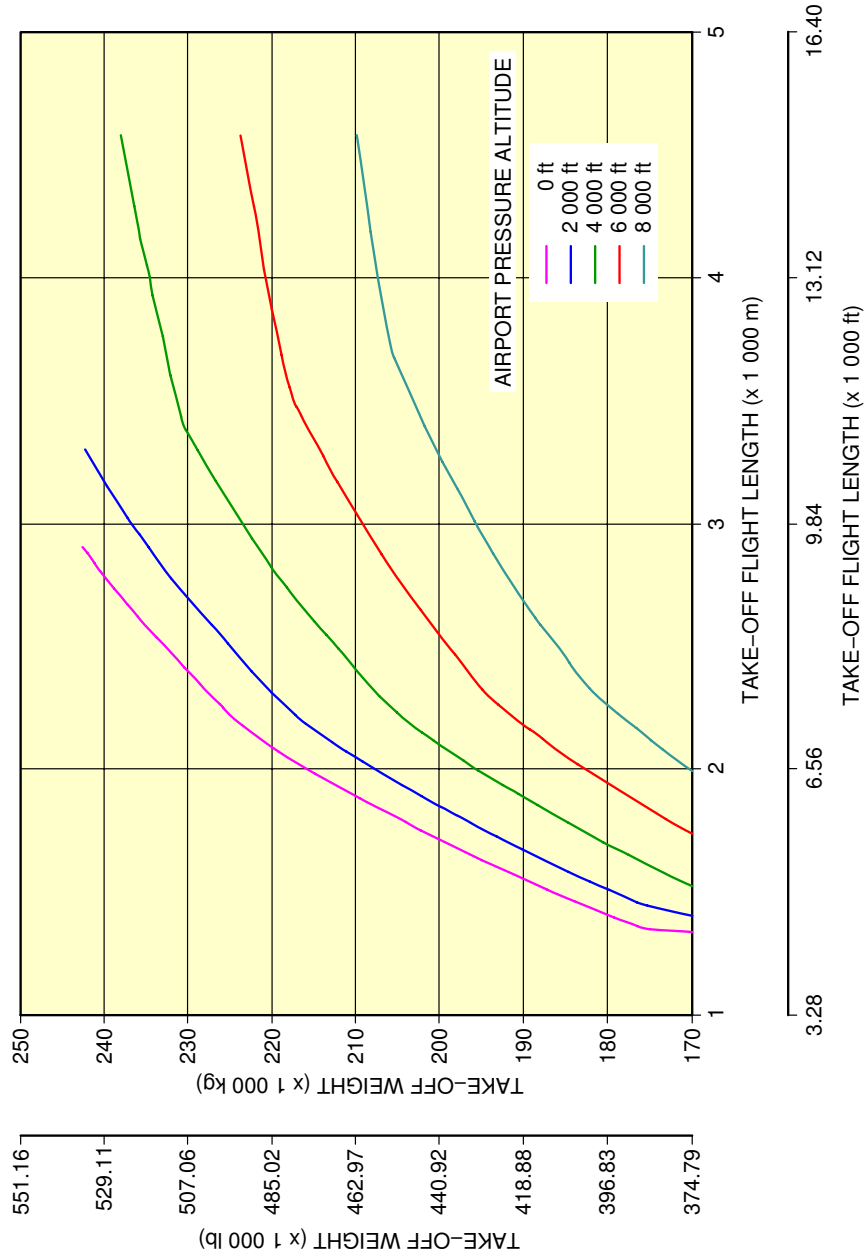

NOTE: THESE CURVES ARE GIVEN FOR INFORMATION ONLY. THE APPROVED VALUES ARE STATED IN THE "OPERATING MANUALS" SPECIFIC TO THE AIRLINE OPERATING THE AIRCRAFT.

F_AC_030301_1_0010101_01_02

Take-Off Weight Limitation
 ISA Conditions - PW 4000 Series Engine
 FIGURE-3-3-1-991-001-A01

**ON A/C A330-200

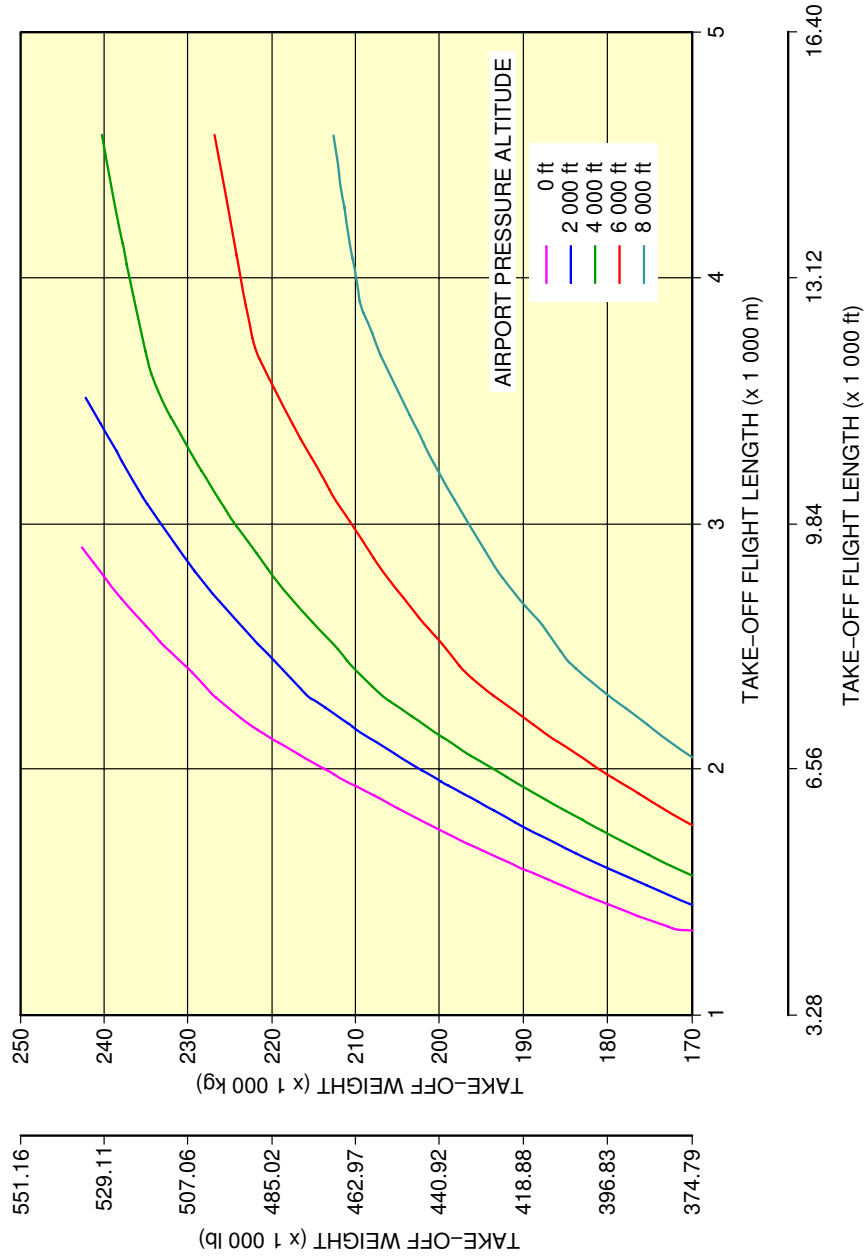

NOTE: THESE CURVES ARE GIVEN FOR INFORMATION ONLY. THE APPROVED VALUES ARE STATED IN THE "OPERATING MANUALS" SPECIFIC TO THE AIRLINE OPERATING THE AIRCRAFT.

F_AC_030301_1_0020101_01_02

Take-Off Weight Limitation
 ISA Conditions - RR TRENT 700 Series Engine
 FIGURE-3-3-1-991-002-A01

**ON A/C A330-200

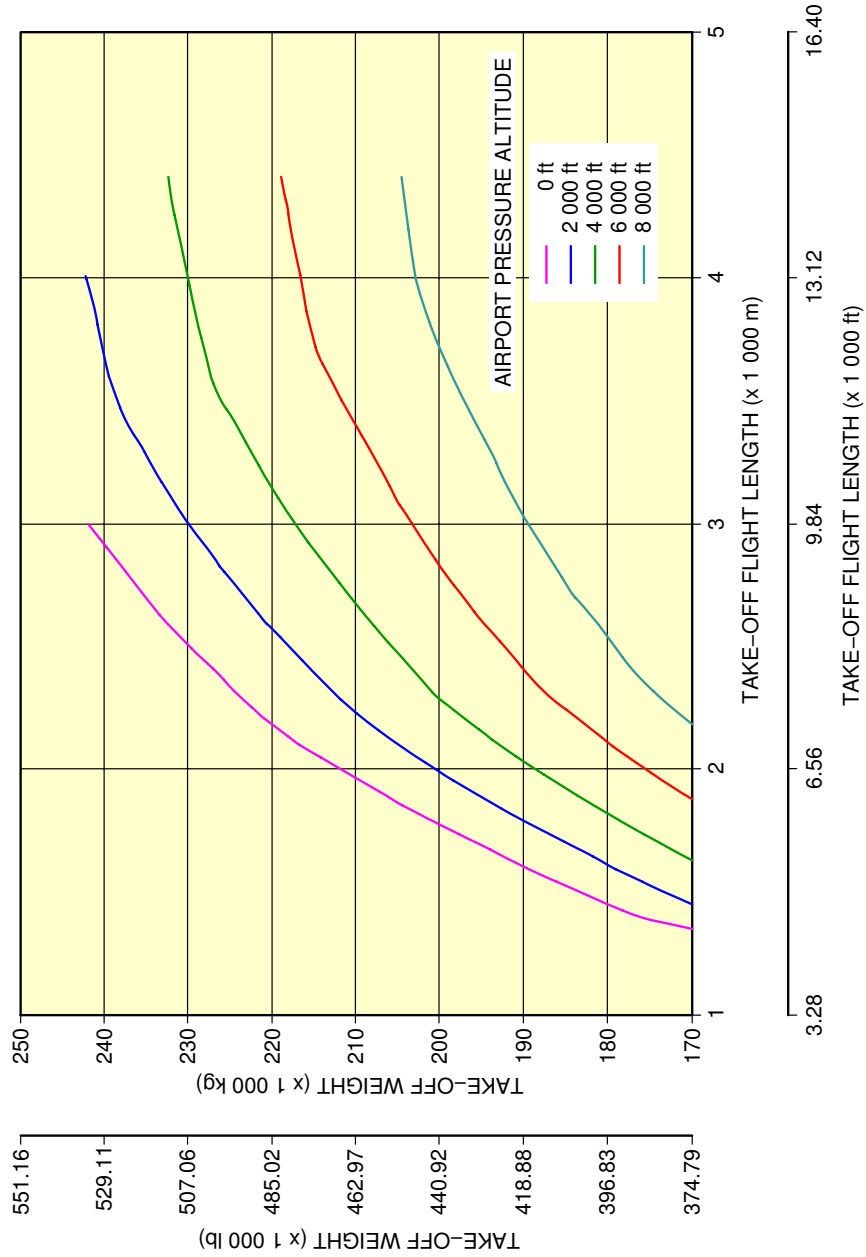

NOTE: THESE CURVES ARE GIVEN FOR INFORMATION ONLY. THE APPROVED VALUES ARE STATED IN THE "OPERATING MANUALS" SPECIFIC TO THE AIRLINE OPERATING THE AIRCRAFT.

F_AC_030301_1_0030101_01_02

Take-Off Weight Limitation
 ISA Conditions - GE CF6-80E1 Series Engine
 FIGURE-3-3-1-991-003-A01

****ON A/C A330-200F**

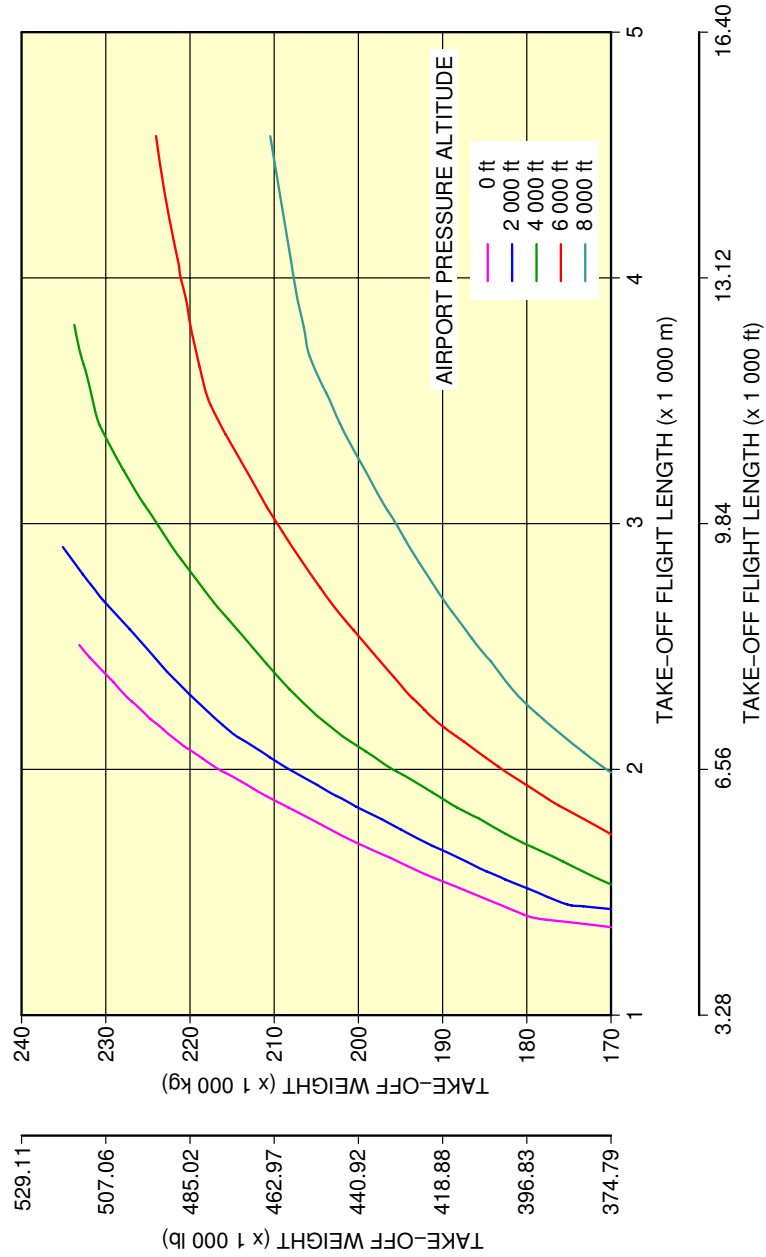

NOTE: THESE CURVES ARE GIVEN FOR INFORMATION ONLY. THE APPROVED VALUES ARE STATED IN THE "OPERATING MANUALS" SPECIFIC TO THE AIRLINE OPERATING THE AIRCRAFT.

F_AC_030301_1_0120101_01_00

Take-Off Weight Limitation
 ISA Conditions - PW 4000 Series Engine
 FIGURE-3-3-1-991-012-A01

****ON A/C A330-200F**

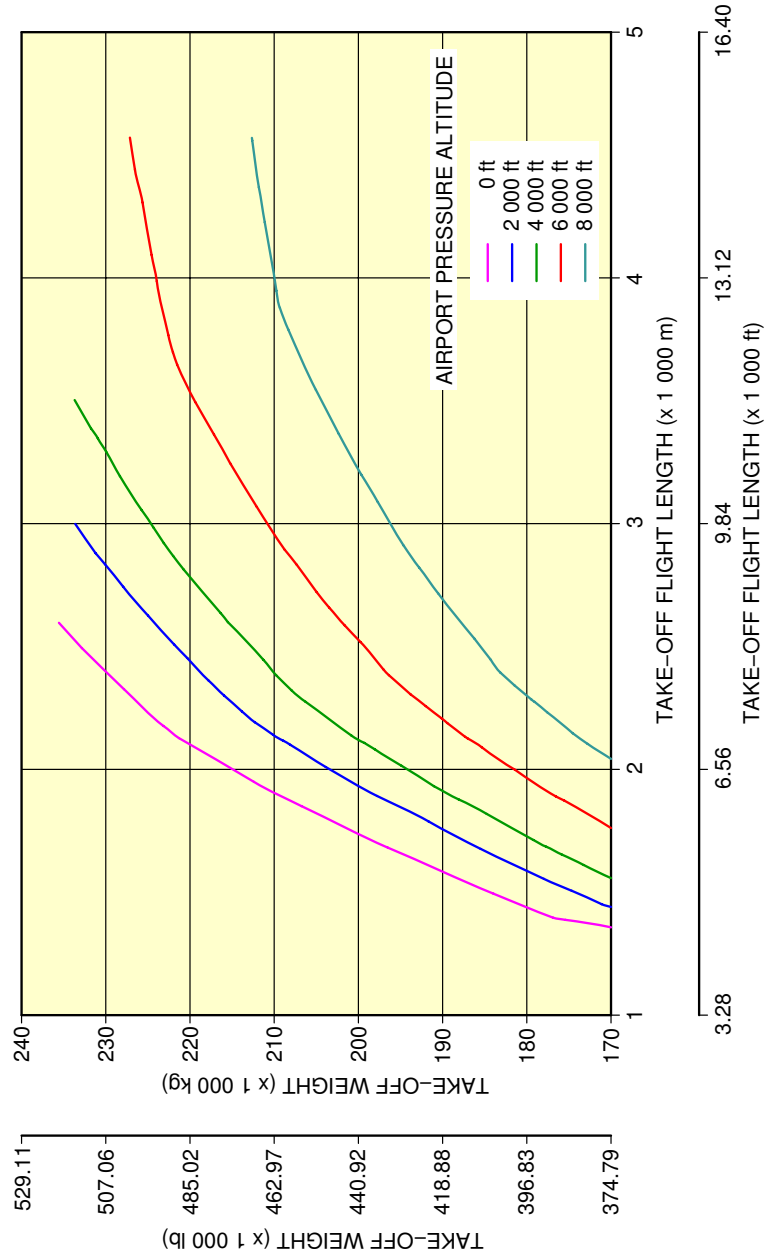

NOTE: THESE CURVES ARE GIVEN FOR INFORMATION ONLY. THE APPROVED VALUES ARE STATED IN THE "OPERATING MANUALS" SPECIFIC TO THE AIRLINE OPERATING THE AIRCRAFT.

F_AC_030301_1_0130101_01_00

Take-Off Weight Limitation
ISA Conditions - RR TRENT 700 Series Engine
FIGURE-3-3-1-991-013-A01

****ON A/C A330-300**

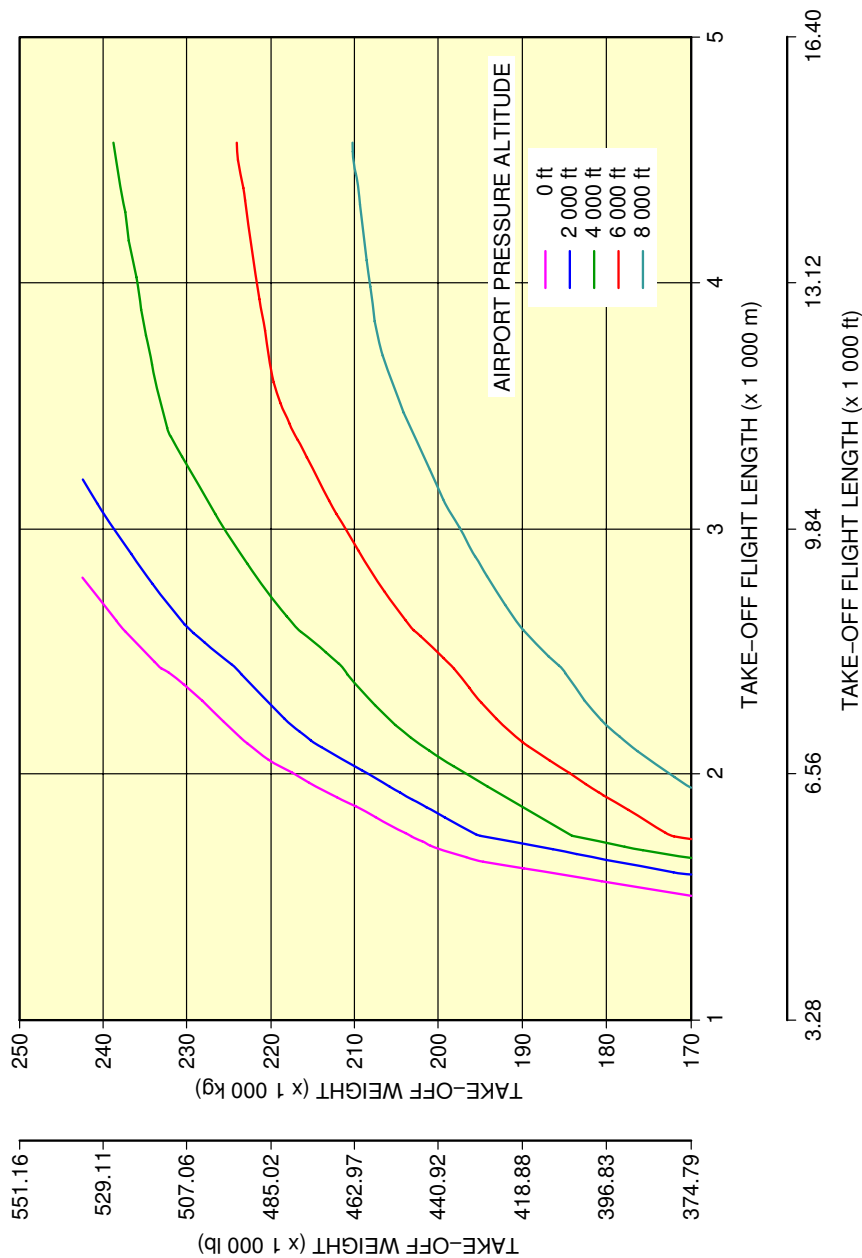

NOTE: THESE CURVES ARE GIVEN FOR INFORMATION ONLY. THE APPROVED VALUES ARE STATED IN THE "OPERATING MANUALS" SPECIFIC TO THE AIRLINE OPERATING THE AIRCRAFT.

F_AC_030301_1_0140101_01_00

Take-Off Weight Limitation
 ISA Conditions - PW 4000 Series Engine
 FIGURE-3-3-1-991-014-A01

**ON A/C A330-300

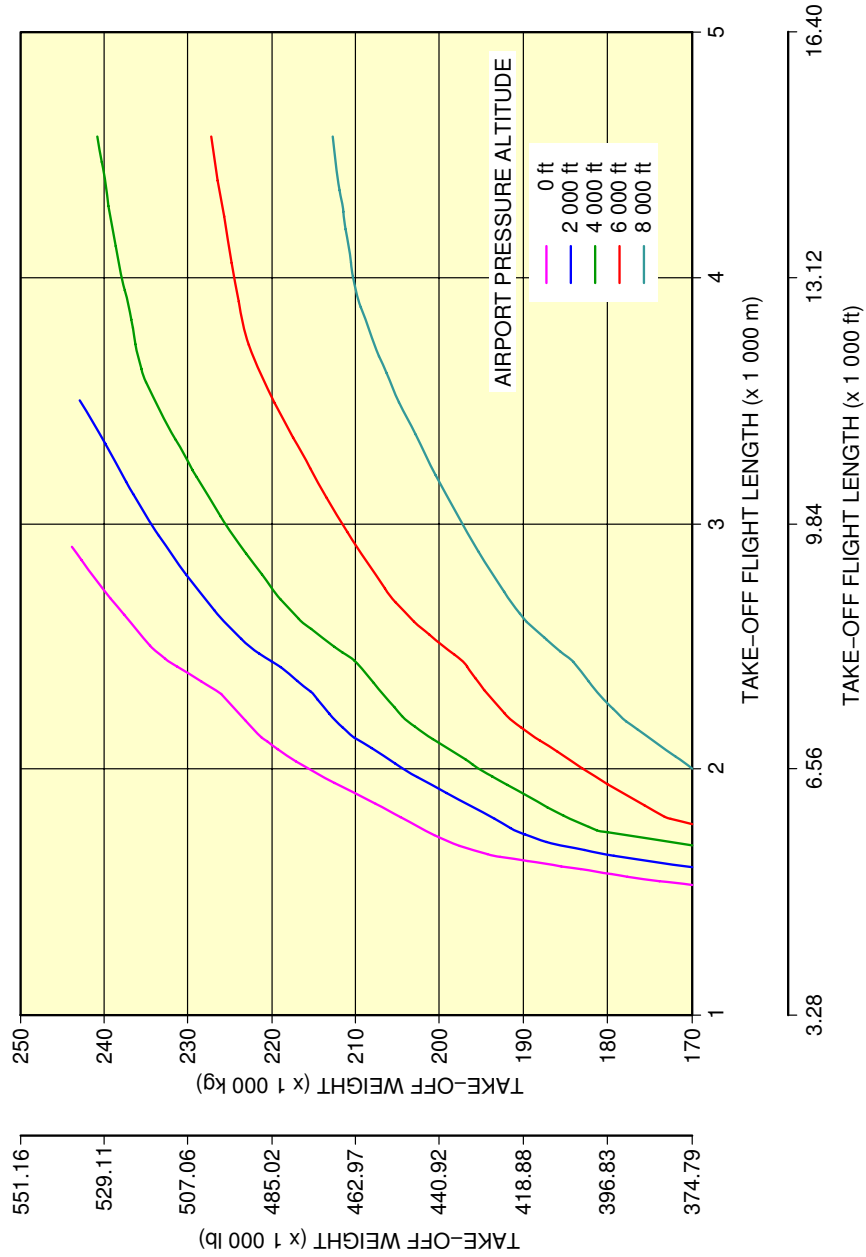

NOTE: THESE CURVES ARE GIVEN FOR INFORMATION ONLY. THE APPROVED VALUES ARE STATED IN THE "OPERATING MANUALS" SPECIFIC TO THE AIRLINE OPERATING THE AIRCRAFT.

F_AC_030301_1_0150101_01_00

Take-Off Weight Limitation
 ISA Conditions - RR TRENT 700 Series Engine
 FIGURE-3-3-1-991-015-A01

**ON A/C A330-300

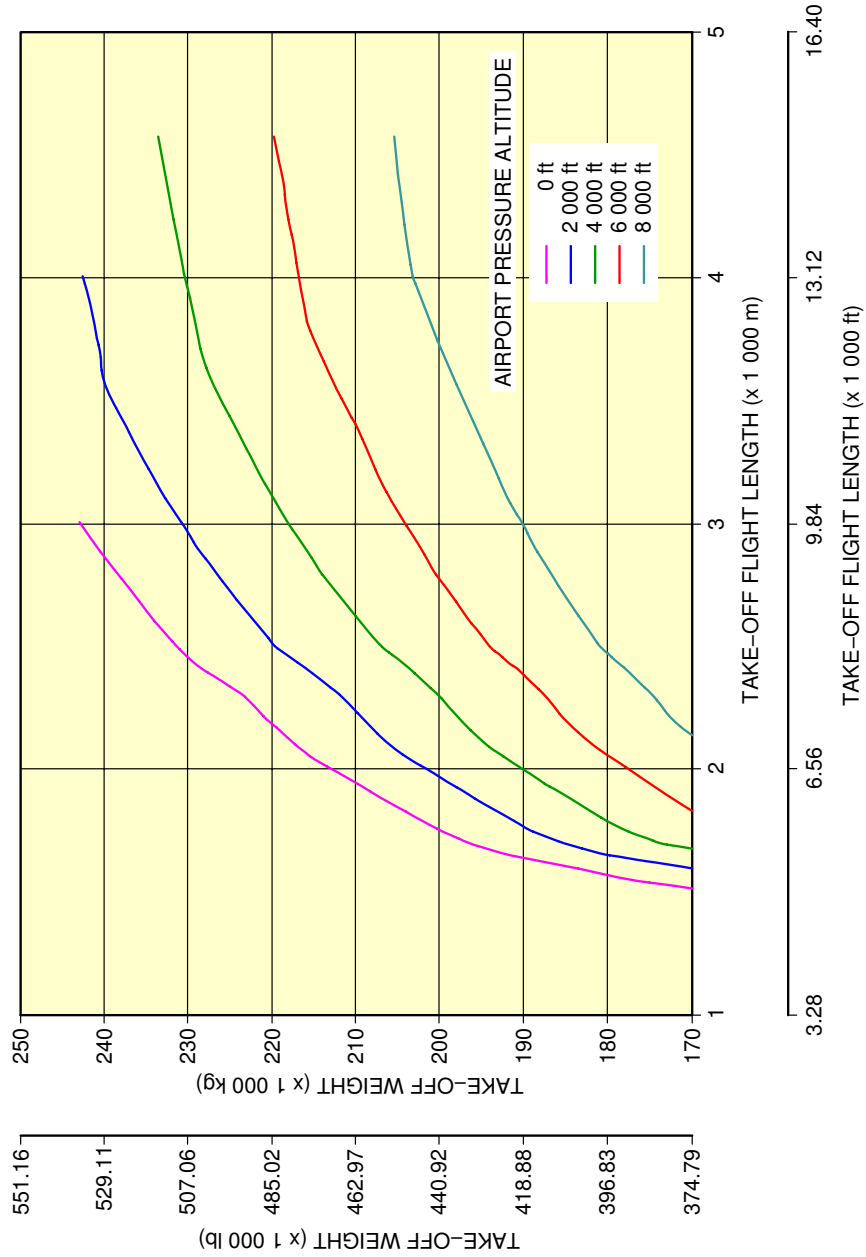

NOTE: THESE CURVES ARE GIVEN FOR INFORMATION ONLY. THE APPROVED VALUES ARE STATED IN THE "OPERATING MANUALS" SPECIFIC TO THE AIRLINE OPERATING THE AIRCRAFT.

F_AC_030301_1_0160101_01_00

Take-Off Weight Limitation
 ISA Conditions - GE CF6-80E1 Series Engine
 FIGURE-3-3-1-991-016-A01

****ON A/C A330-900**

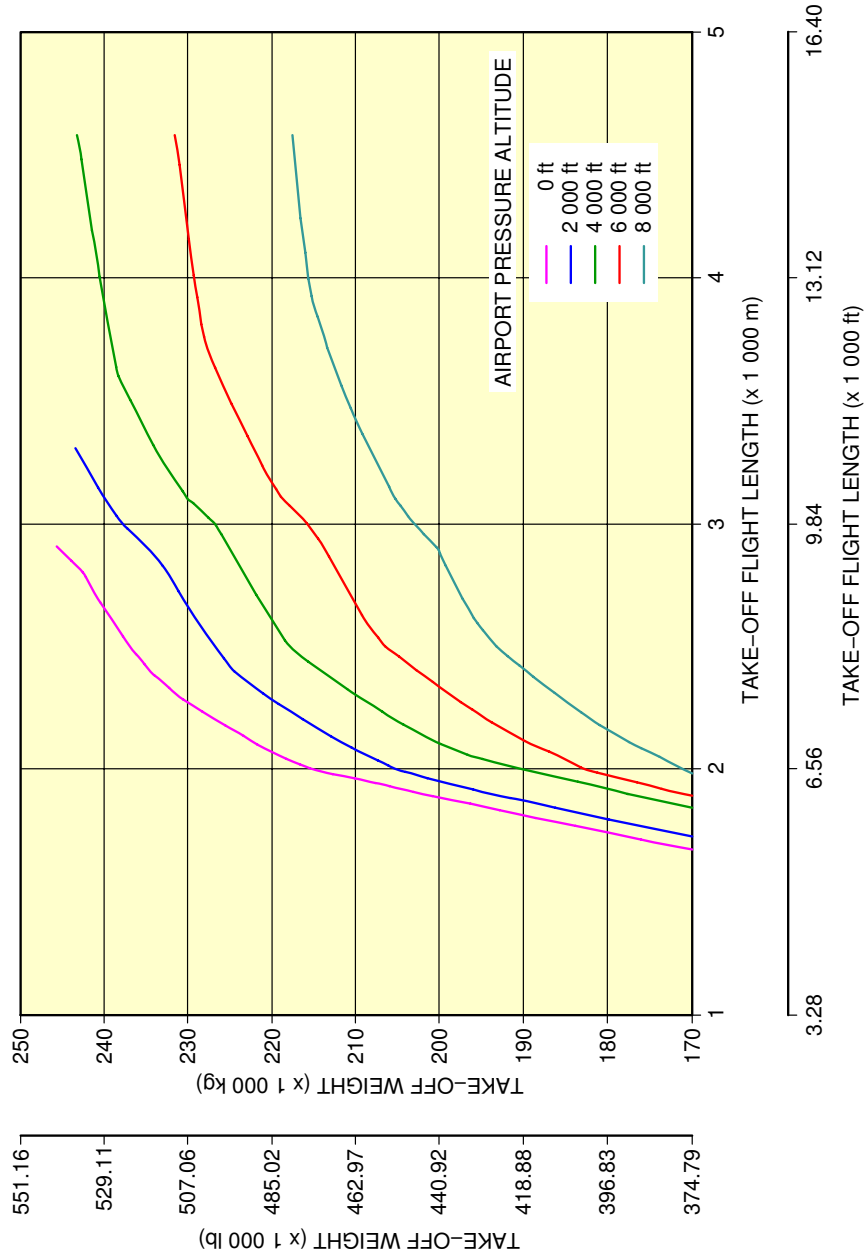

NOTE: THESE CURVES ARE GIVEN FOR INFORMATION ONLY. THE APPROVED VALUES ARE STATED IN THE "OPERATING MANUALS" SPECIFIC TO THE AIRLINE OPERATING THE AIRCRAFT.

F_AC_030301_1_0170101_01_00

Take-Off Weight Limitation
ISA Conditions - RR TRENT 7000 Series Engine
FIGURE-3-3-1-991-017-A01



3-3-2 Take-Off Weight Limitation - ISA +15 ° C (+59 ° F) Conditions

****ON A/C A330-200 A330-200F A330-300 A330-900**

Take-Off Weight Limitation - ISA +15 ° C (+27 ° F) Conditions

1. This section gives the take-off weight limitation at ISA +15 ° C (+27 ° F) conditions.

**ON A/C A330-200

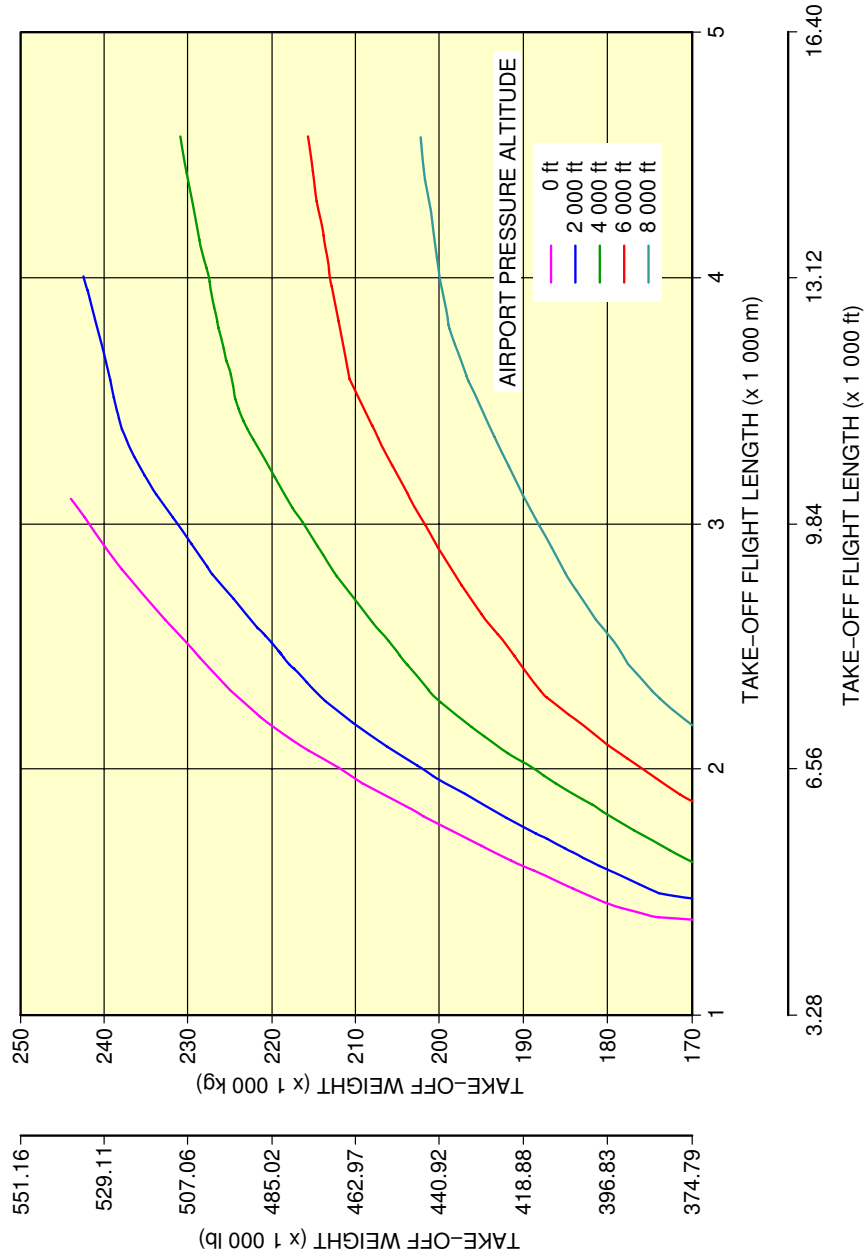

NOTE: THESE CURVES ARE GIVEN FOR INFORMATION ONLY. THE APPROVED VALUES ARE STATED IN THE "OPERATING MANUALS" SPECIFIC TO THE AIRLINE OPERATING THE AIRCRAFT.

F_AC_030302_1_0010101_01_02

Take-Off Weight Limitation
 ISA +15 °C (+27 °F) Conditions - PW 4000 Series Engine
 FIGURE-3-3-2-991-001-A01

**ON A/C A330-200

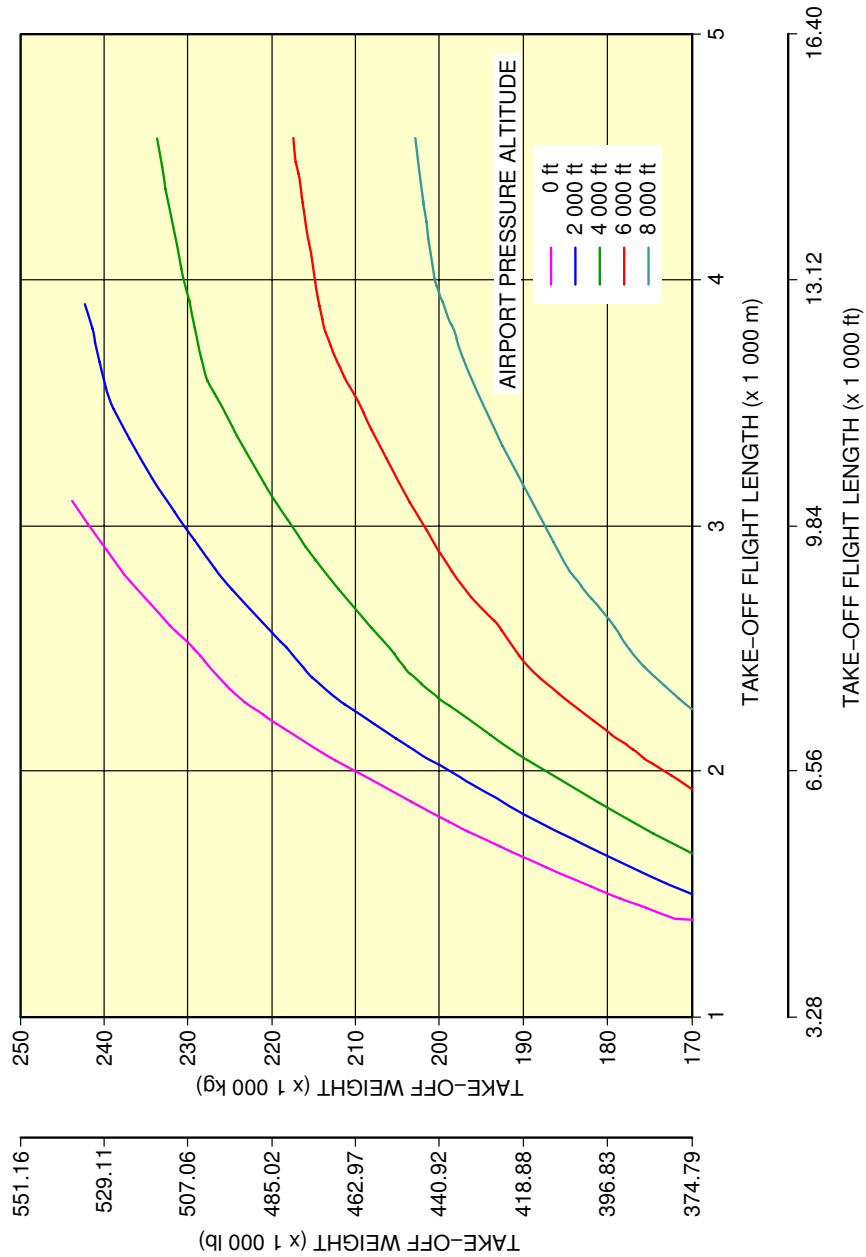

NOTE: THESE CURVES ARE GIVEN FOR INFORMATION ONLY. THE APPROVED VALUES ARE STATED IN THE "OPERATING MANUALS" SPECIFIC TO THE AIRLINE OPERATING THE AIRCRAFT.

F_AC_030302_1_0020101_01_02

Take-Off Weight Limitation
 ISA +15 °C (+27 °F) Conditions - RR TRENT 700 Series Engine
 FIGURE-3-3-2-991-002-A01

****ON A/C A330-200**

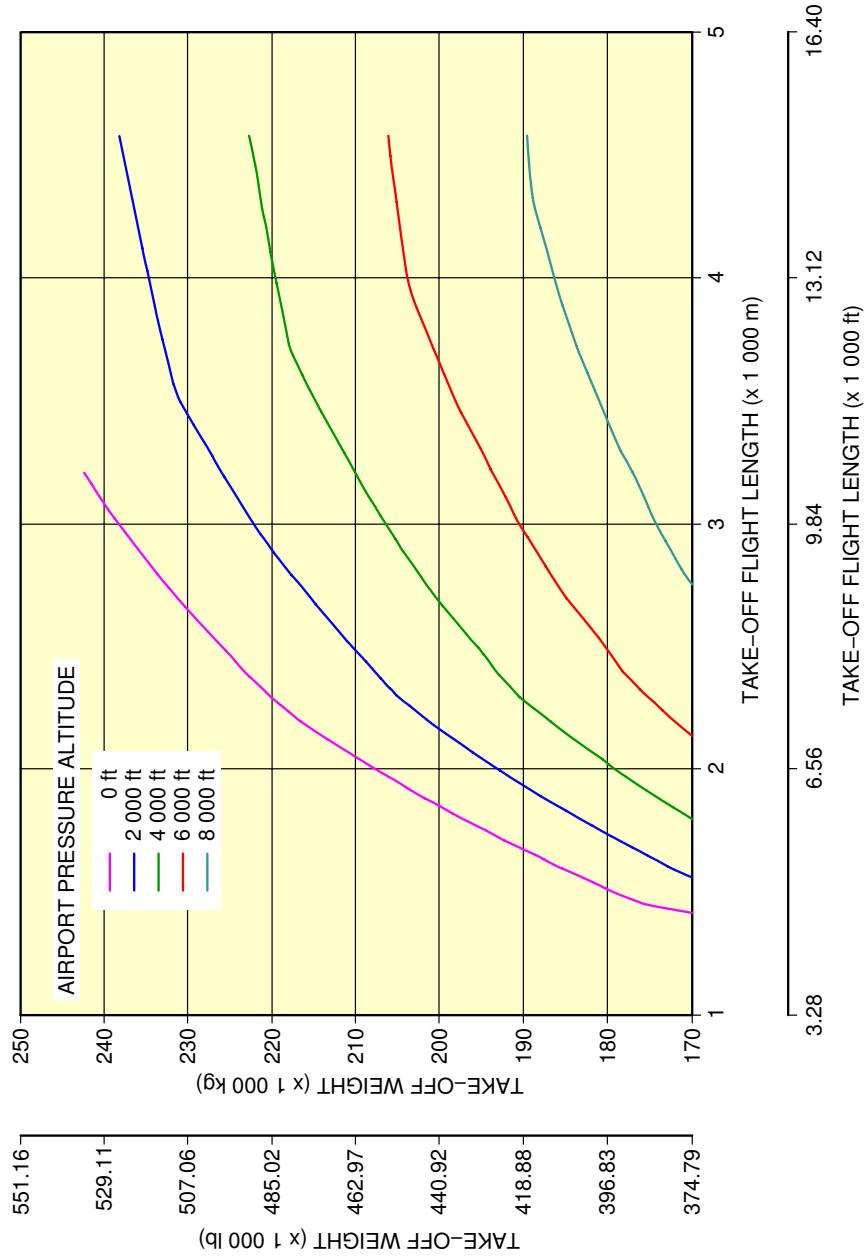

NOTE: THESE CURVES ARE GIVEN FOR INFORMATION ONLY. THE APPROVED VALUES ARE STATED IN THE "OPERATING MANUALS" SPECIFIC TO THE AIRLINE OPERATING THE AIRCRAFT.

F_AC_030302_1_0030101_01_02

Take-Off Weight Limitation
 ISA +15 °C (+27 °F) Conditions - GE CF6-80E1 Series Engine
 FIGURE-3-3-2-991-003-A01

**ON A/C A330-200F

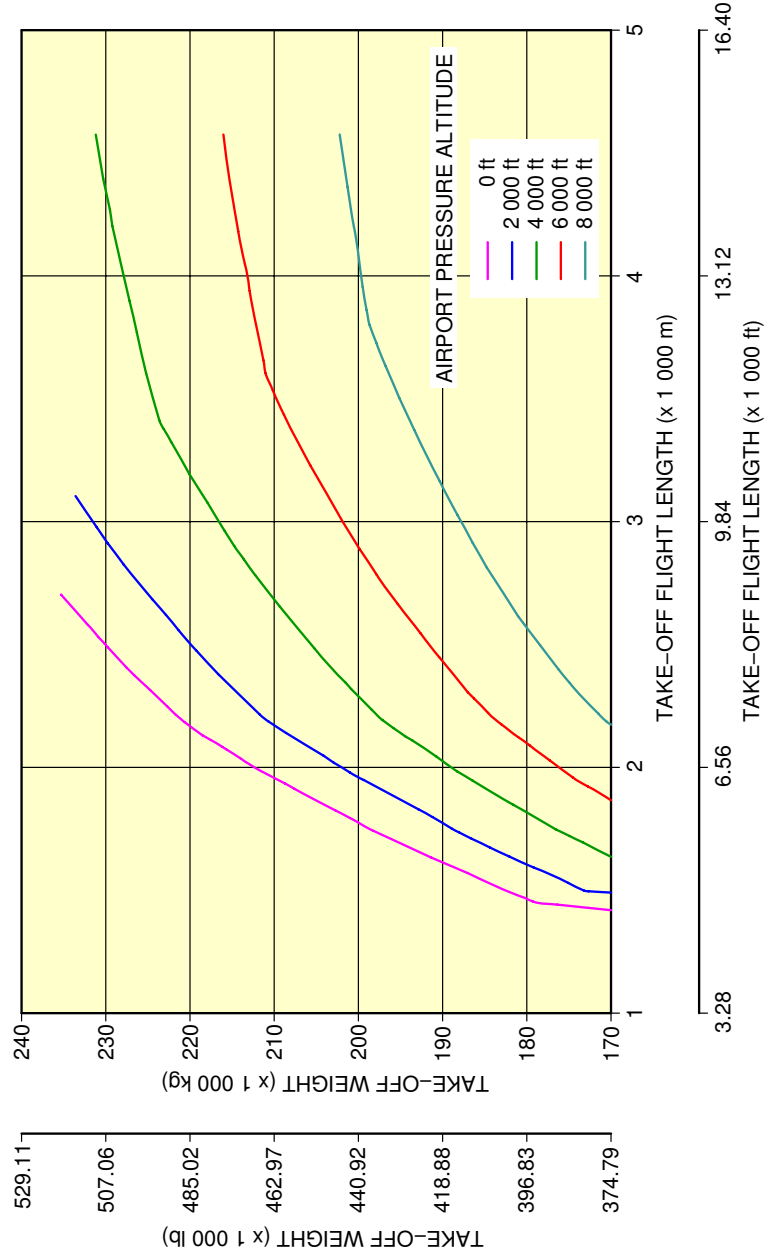

NOTE: THESE CURVES ARE GIVEN FOR INFORMATION ONLY. THE APPROVED VALUES ARE STATED IN THE "OPERATING MANUALS" SPECIFIC TO THE AIRLINE OPERATING THE AIRCRAFT.

F_AC_030302_1_0120101_01_00

Take-Off Weight Limitation
 ISA +15 °C (+27 °F) Conditions - PW 4000 Series Engine
 FIGURE-3-3-2-991-012-A01

****ON A/C A330-200F**

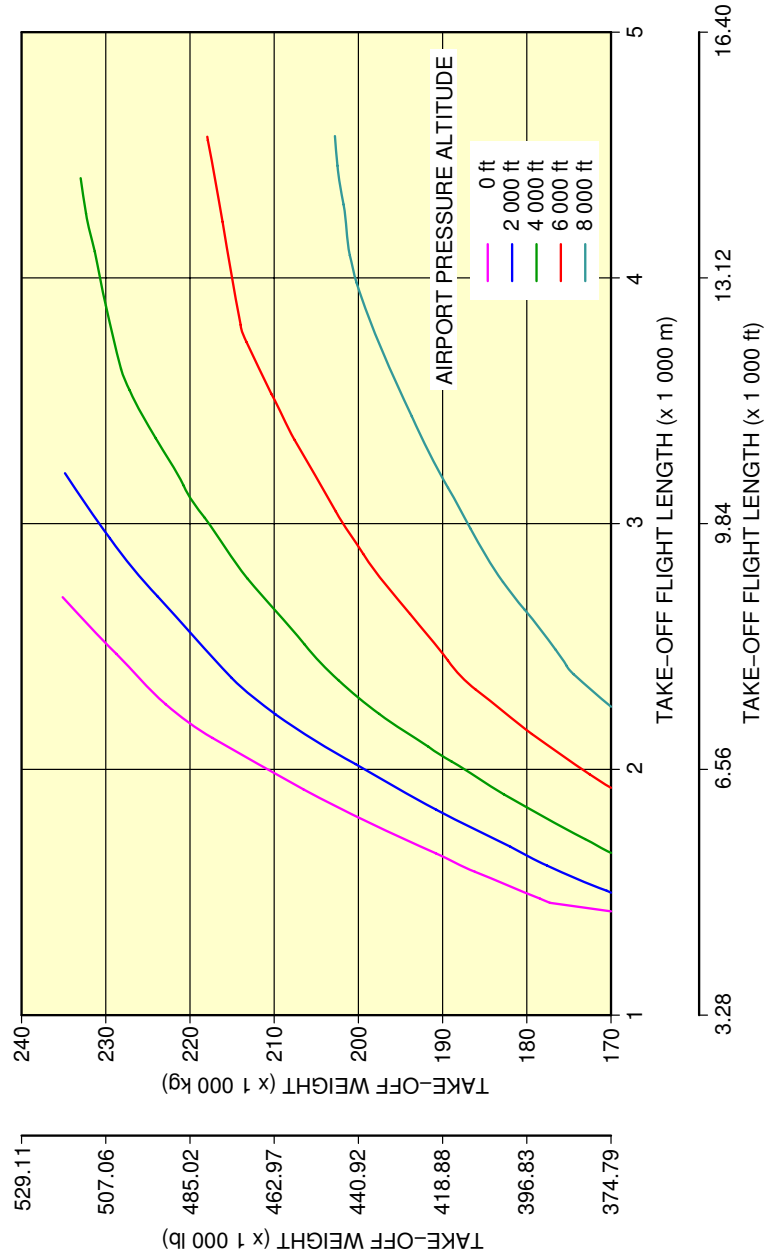

NOTE: THESE CURVES ARE GIVEN FOR INFORMATION ONLY. THE APPROVED VALUES ARE STATED IN THE "OPERATING MANUALS" SPECIFIC TO THE AIRLINE OPERATING THE AIRCRAFT.

F_AC_030302_1_0130101_01_00

Take-Off Weight Limitation
 ISA +15 °C (+27 °F) Conditions - RR TRENT 700 Series Engine
 FIGURE-3-3-2-991-013-A01

****ON A/C A330-300**

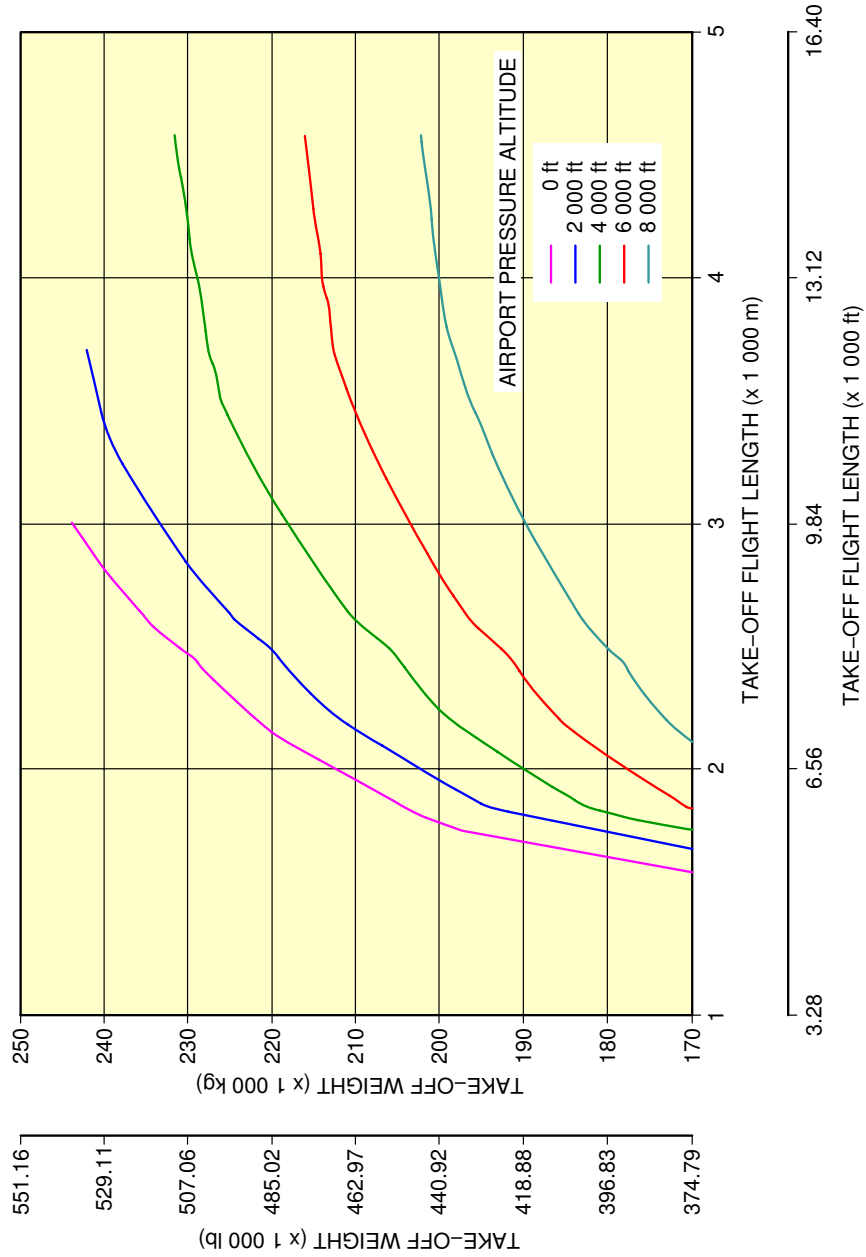

NOTE: THESE CURVES ARE GIVEN FOR INFORMATION ONLY. THE APPROVED VALUES ARE STATED IN THE "OPERATING MANUALS" SPECIFIC TO THE AIRLINE OPERATING THE AIRCRAFT.

F_AC_030302_1_0140101_01_00

Take-Off Weight Limitation
 ISA +15 °C (+27 °F) Conditions - PW 4000 Series Engine
 FIGURE-3-3-2-991-014-A01

**ON A/C A330-300

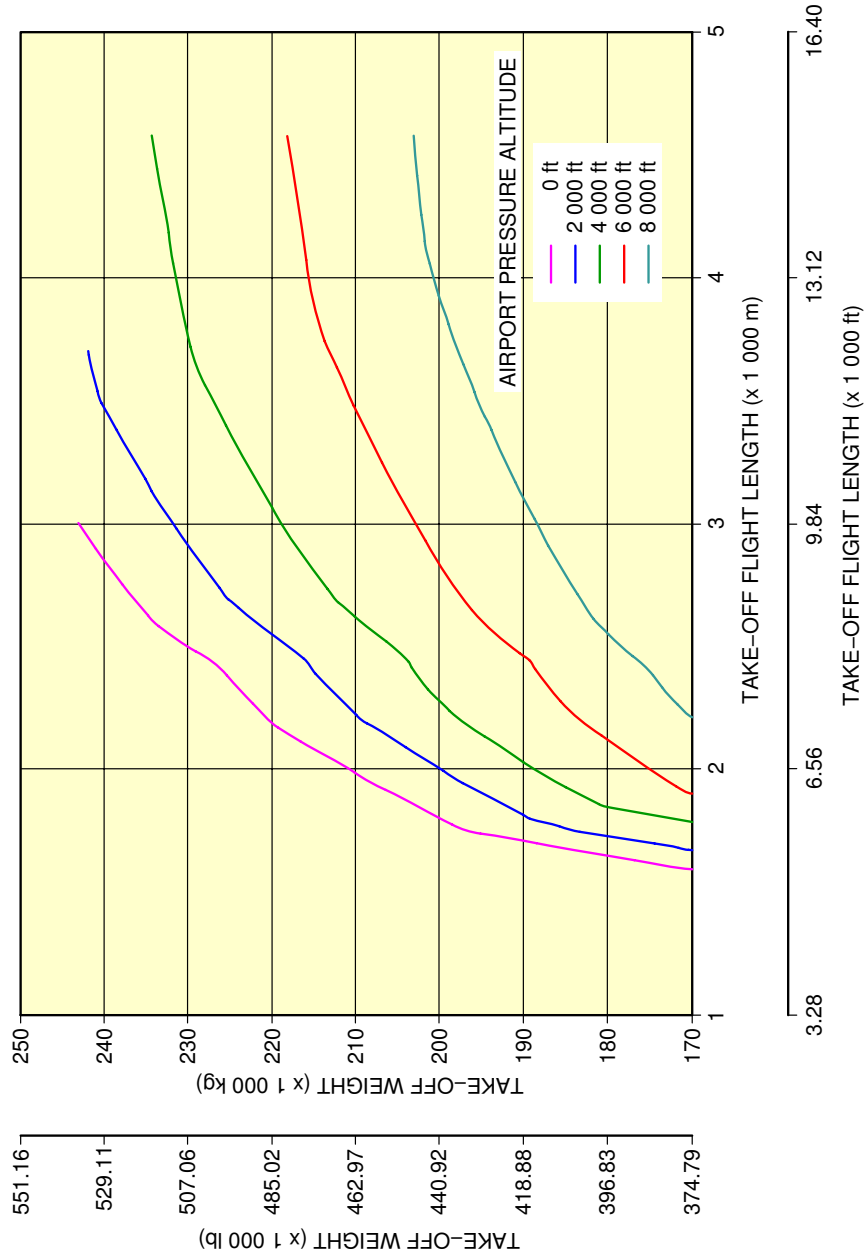

NOTE: THESE CURVES ARE GIVEN FOR INFORMATION ONLY. THE APPROVED VALUES ARE STATED IN THE "OPERATING MANUALS" SPECIFIC TO THE AIRLINE OPERATING THE AIRCRAFT.

F_AC_030302_1_0150101_01_00

Take-Off Weight Limitation
 ISA +15 °C (+27 °F) Conditions - RR TRENT 700 Series Engine
 FIGURE-3-3-2-991-015-A01

**ON A/C A330-300

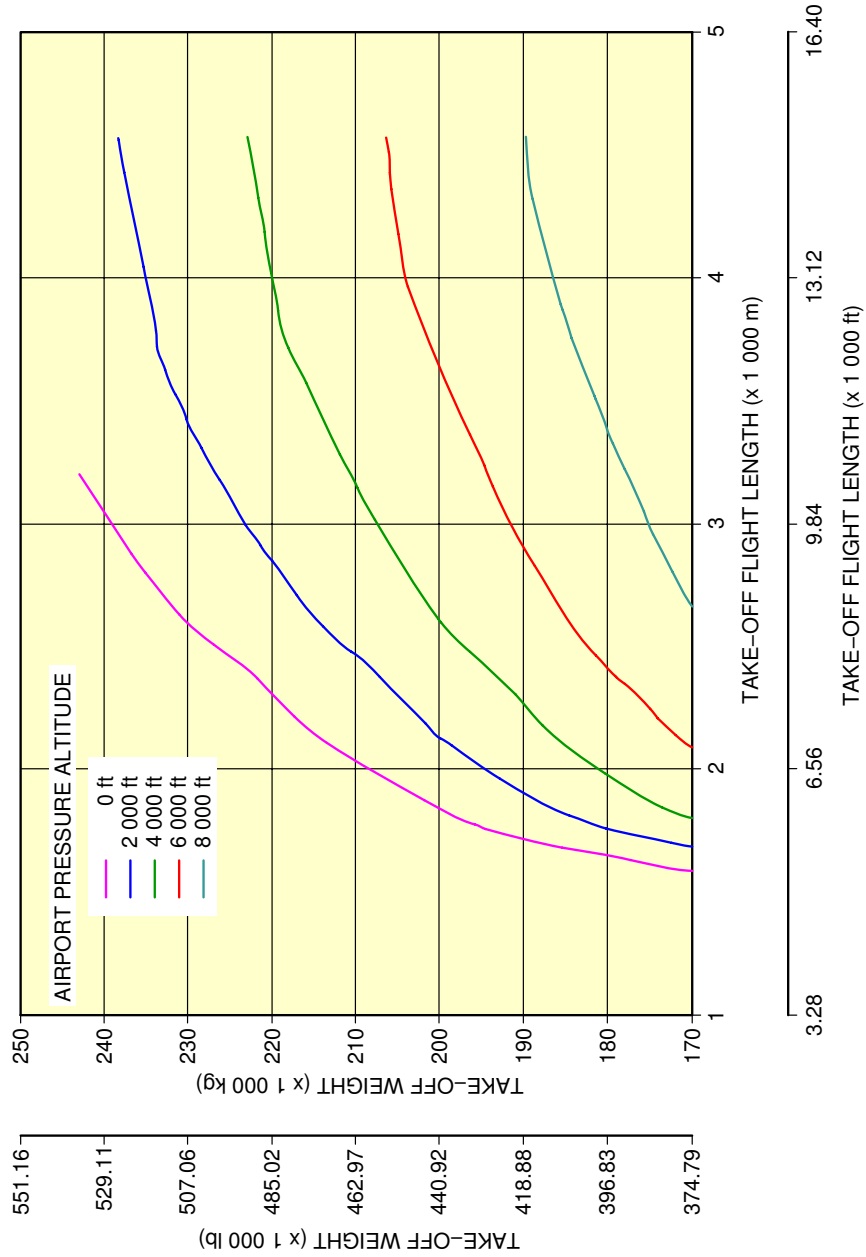

NOTE: THESE CURVES ARE GIVEN FOR INFORMATION ONLY. THE APPROVED VALUES ARE STATED IN THE "OPERATING MANUALS" SPECIFIC TO THE AIRLINE OPERATING THE AIRCRAFT.

F_AC_030302_1_0160101_01_00

Take-Off Weight Limitation
 ISA +15 ° C (+27 ° F) Conditions - GE CF6-80E1 Series Engine
 FIGURE-3-3-2-991-016-A01

****ON A/C A330-900**

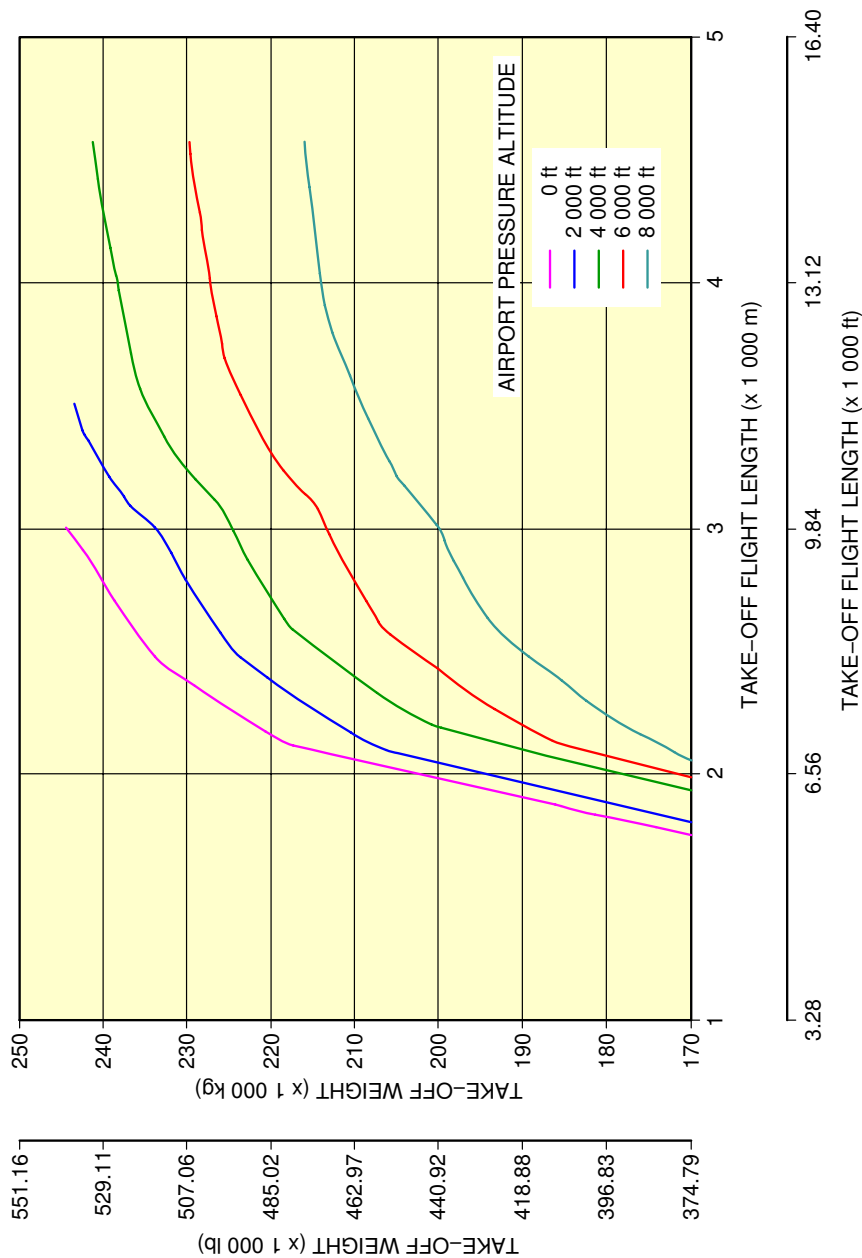

NOTE: THESE CURVES ARE GIVEN FOR INFORMATION ONLY. THE APPROVED VALUES ARE STATED IN THE "OPERATING MANUALS" SPECIFIC TO THE AIRLINE OPERATING THE AIRCRAFT.

F_AC_030302_1_0170101_01_00

Take-Off Weight Limitation
 ISA +15 °C (+27 °F) Conditions - RR TRENT 7000 Series Engine
 FIGURE-3-3-2-991-017-A01



3-3-3 Aerodrome Reference Code

****ON A/C A330-200 A330-200F A330-300 A330-800 A330-900**

Aerodrome Reference Code

1. A330-200, A330-200F, A330-300, A330-800 and A330-900 can operate on aerodromes classified as code 4E as per ICAO Aerodrome Reference Code.



3-4-1 Landing Field Length - ISA Conditions

****ON A/C A330-200 A330-200F A330-300 A330-900**

Landing Field Length - ISA Conditions

1. This section gives the landing field length.

****ON A/C A330-200**

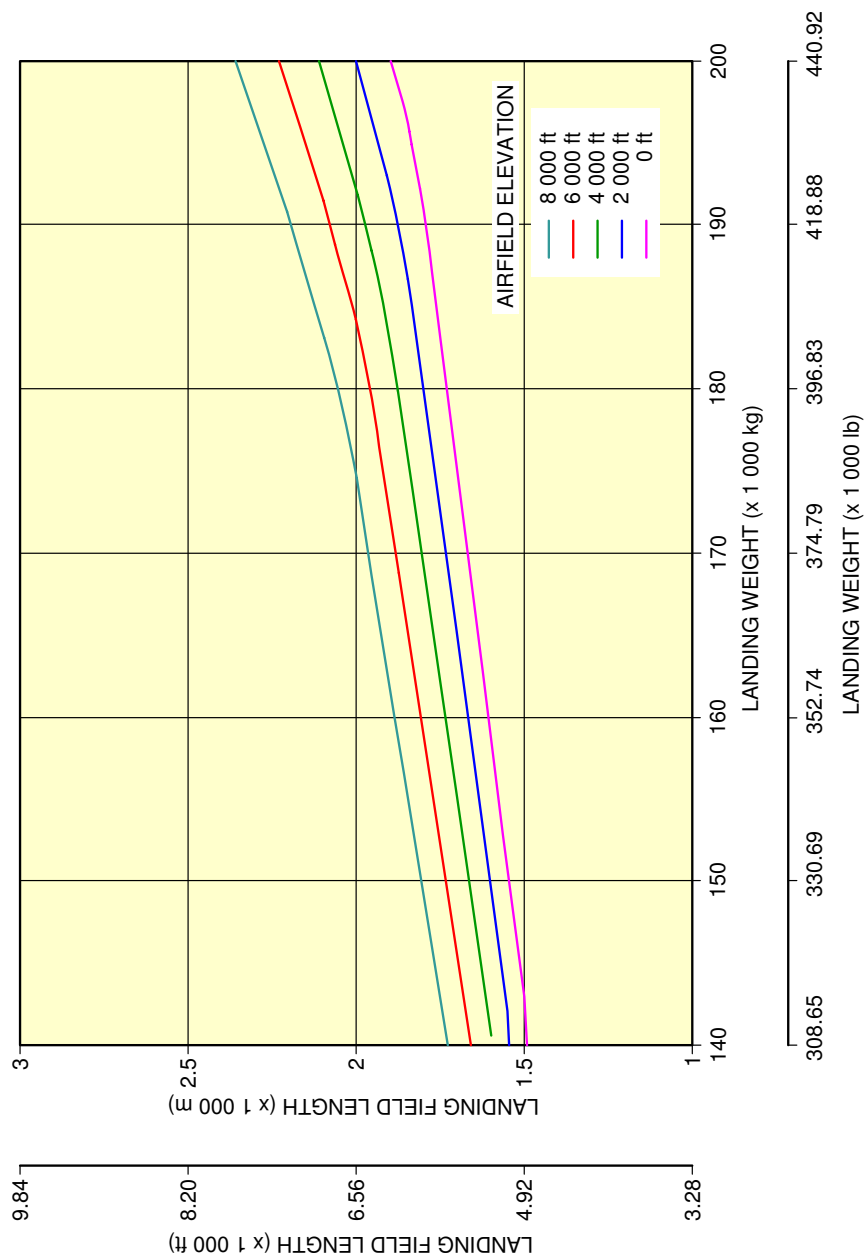

NOTE: THESE CURVES ARE GIVEN FOR INFORMATION ONLY. THE APPROVED VALUES ARE STATED IN THE "OPERATING MANUALS" SPECIFIC TO THE AIRLINE OPERATING THE AIRCRAFT.

F_AC_030401_1_0010101_01_03

Landing Field Length
 ISA Conditions - PW 4000 Series Engine
 FIGURE-3-4-1-991-001-A01

****ON A/C A330-200**

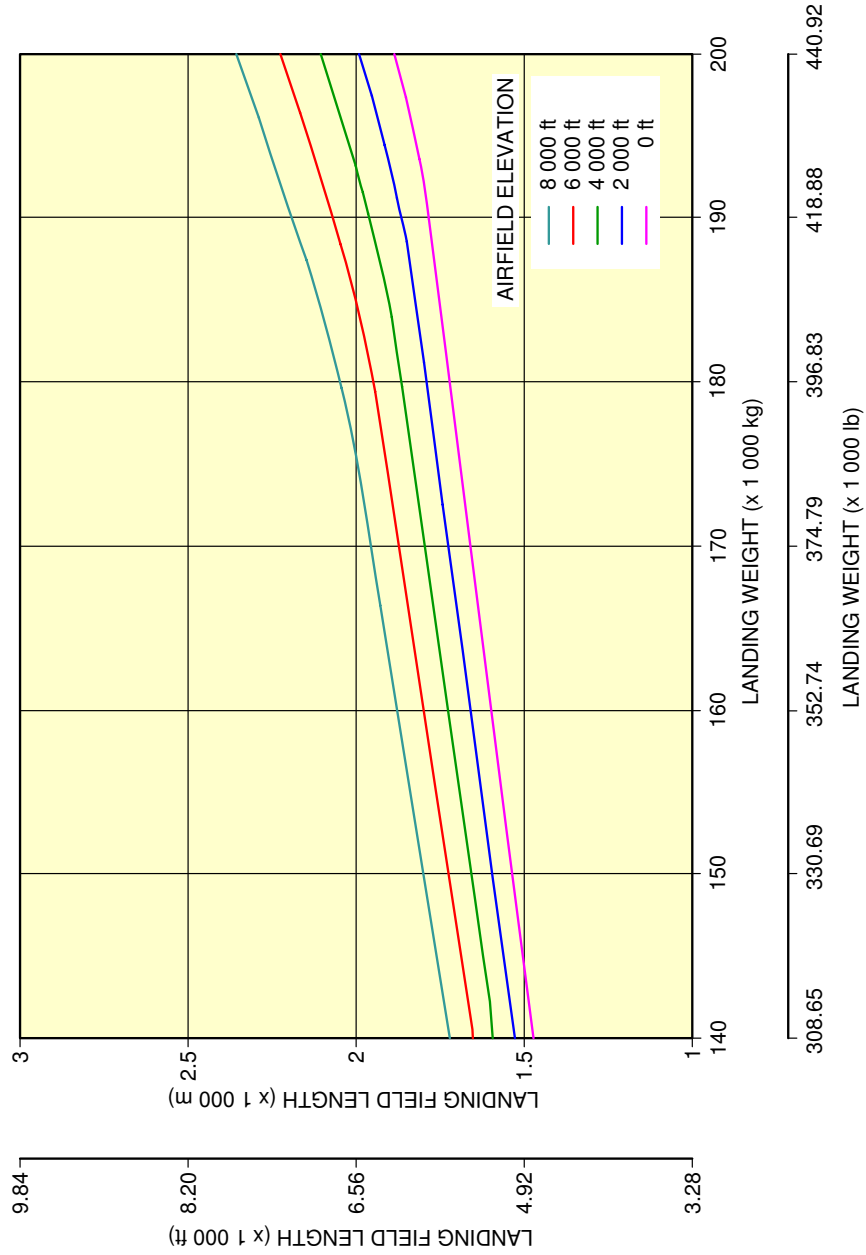

NOTE:
THESE CURVES ARE GIVEN FOR INFORMATION ONLY. THE APPROVED VALUES ARE STATED IN THE "OPERATING MANUALS" SPECIFIC TO THE AIRLINE OPERATING THE AIRCRAFT.

F_AC_030401_1_0020101_01_03

Landing Field Length
ISA Conditions - RR TRENT 700 Series Engine
FIGURE-3-4-1-991-002-A01

****ON A/C A330-200**

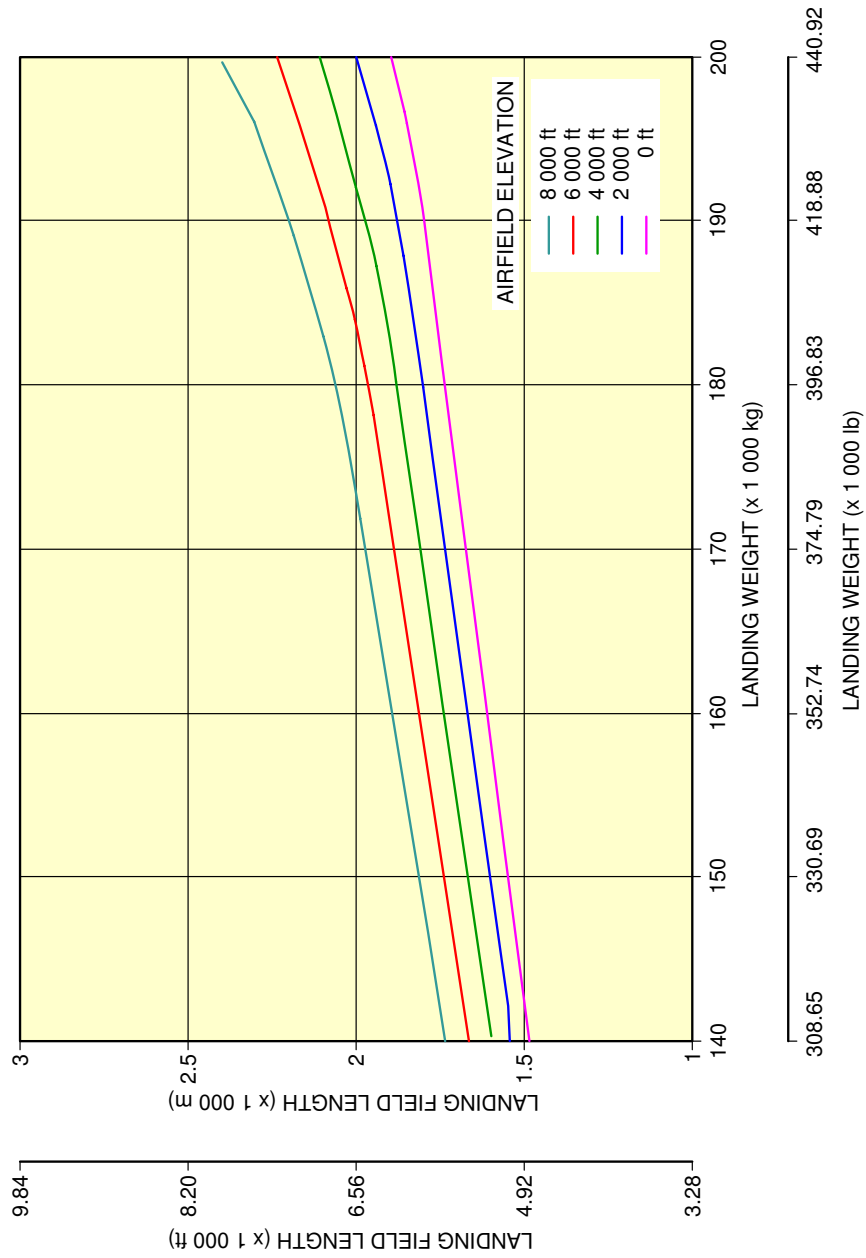

NOTE:
THESE CURVES ARE GIVEN FOR INFORMATION ONLY. THE APPROVED VALUES ARE STATED IN THE "OPERATING MANUALS" SPECIFIC TO THE AIRLINE OPERATING THE AIRCRAFT.

F_AC_030401_1_0030101_01_03

Landing Field Length
ISA Conditions - GE CF6-80E1 Series Engine
FIGURE-3-4-1-991-003-A01

****ON A/C A330-200F**

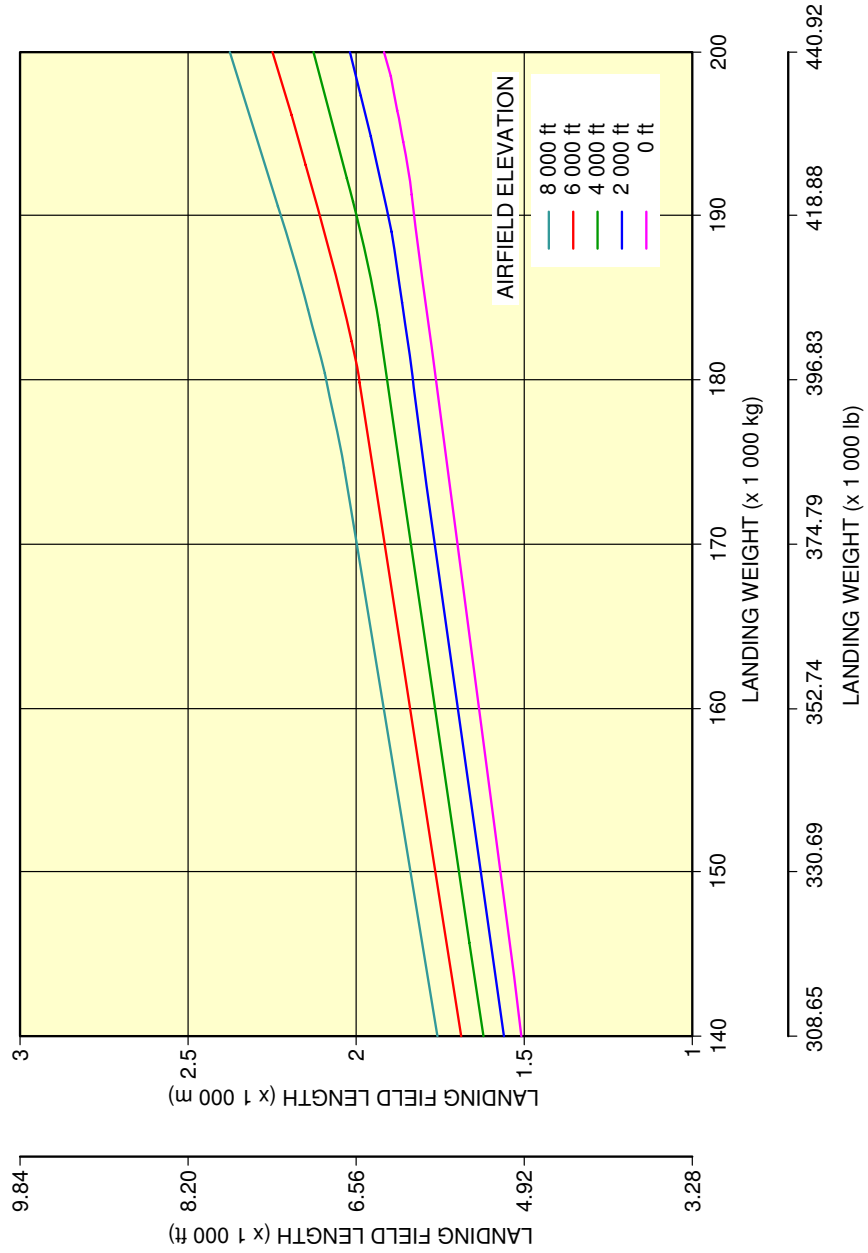

NOTE:
THESE CURVES ARE GIVEN FOR INFORMATION ONLY. THE APPROVED VALUES ARE STATED IN THE "OPERATING MANUALS" SPECIFIC TO THE AIRLINE OPERATING THE AIRCRAFT.

F_AC_030401_1_0120101_01_00

Landing Field Length
ISA Conditions - PW 4000 Series Engine
FIGURE-3-4-1-991-012-A01

****ON A/C A330-200F**

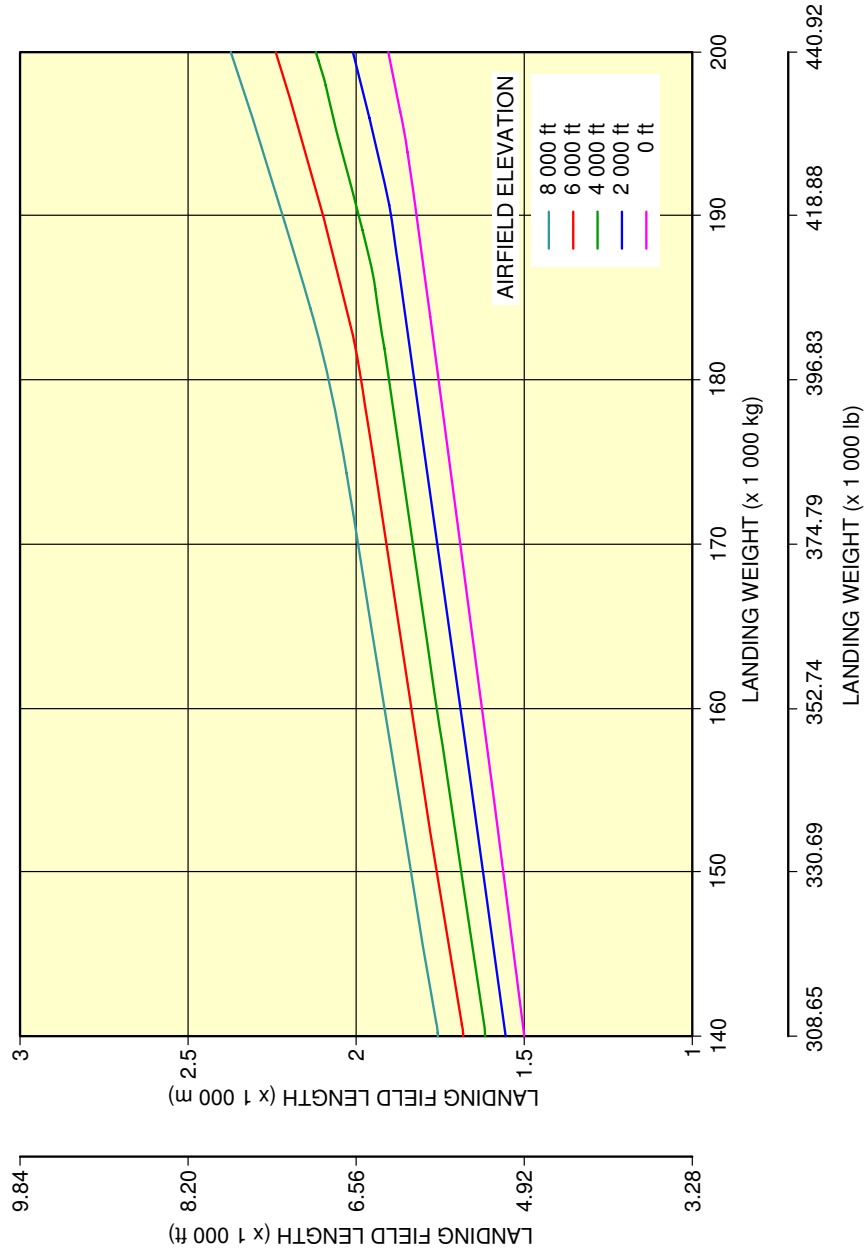

NOTE:
THESE CURVES ARE GIVEN FOR INFORMATION ONLY. THE APPROVED VALUES ARE STATED IN THE "OPERATING MANUALS" SPECIFIC TO THE AIRLINE OPERATING THE AIRCRAFT.

F_AC_030401_1_0130101_01_00

Landing Field Length
ISA Conditions - RR TRENT 700 Series Engine
FIGURE-3-4-1-991-013-A01

****ON A/C A330-300**

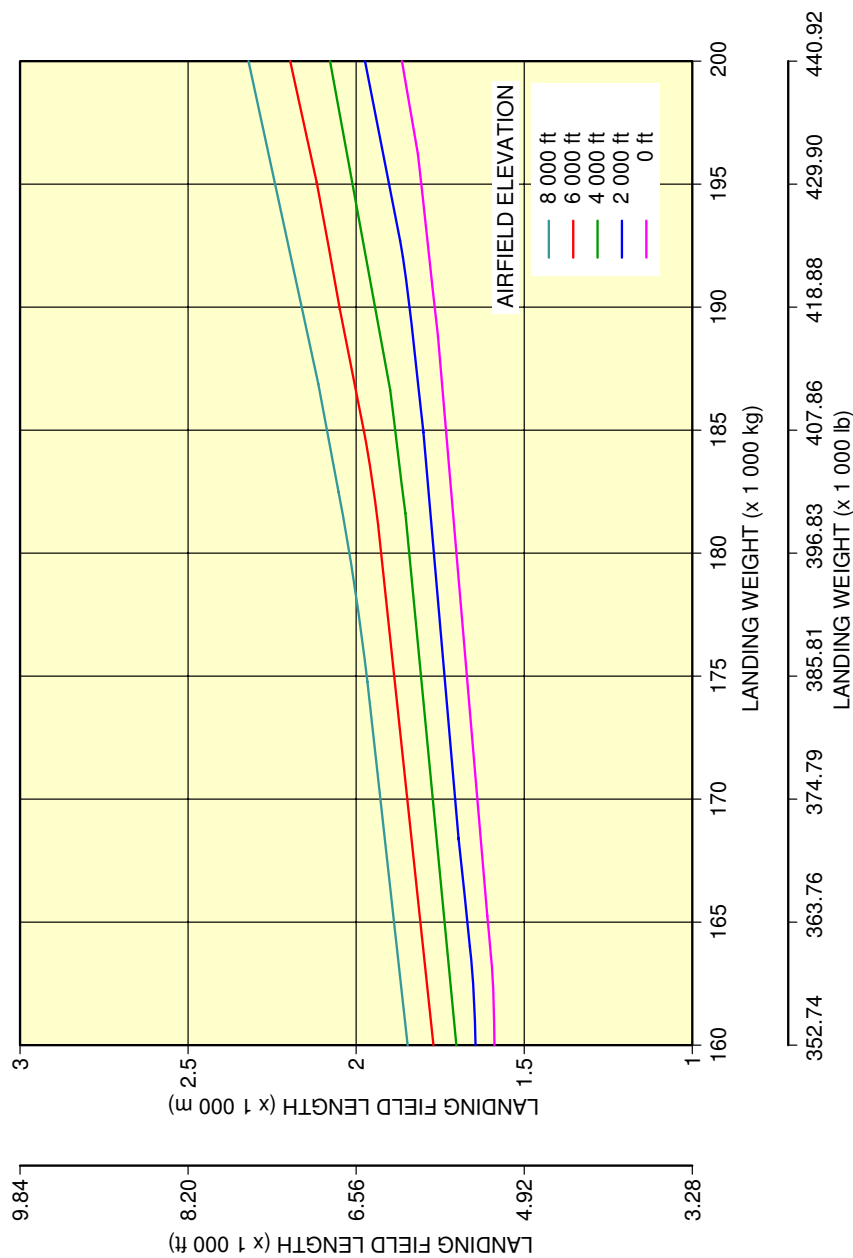

NOTE: THESE CURVES ARE GIVEN FOR INFORMATION ONLY. THE APPROVED VALUES ARE STATED IN THE "OPERATING MANUALS" SPECIFIC TO THE AIRLINE OPERATING THE AIRCRAFT.

F_AC_030401_1_0140101_01_00

Landing Field Length
ISA Conditions - PW 4000 Series Engine
FIGURE-3-4-1-991-014-A01

****ON A/C A330-300**

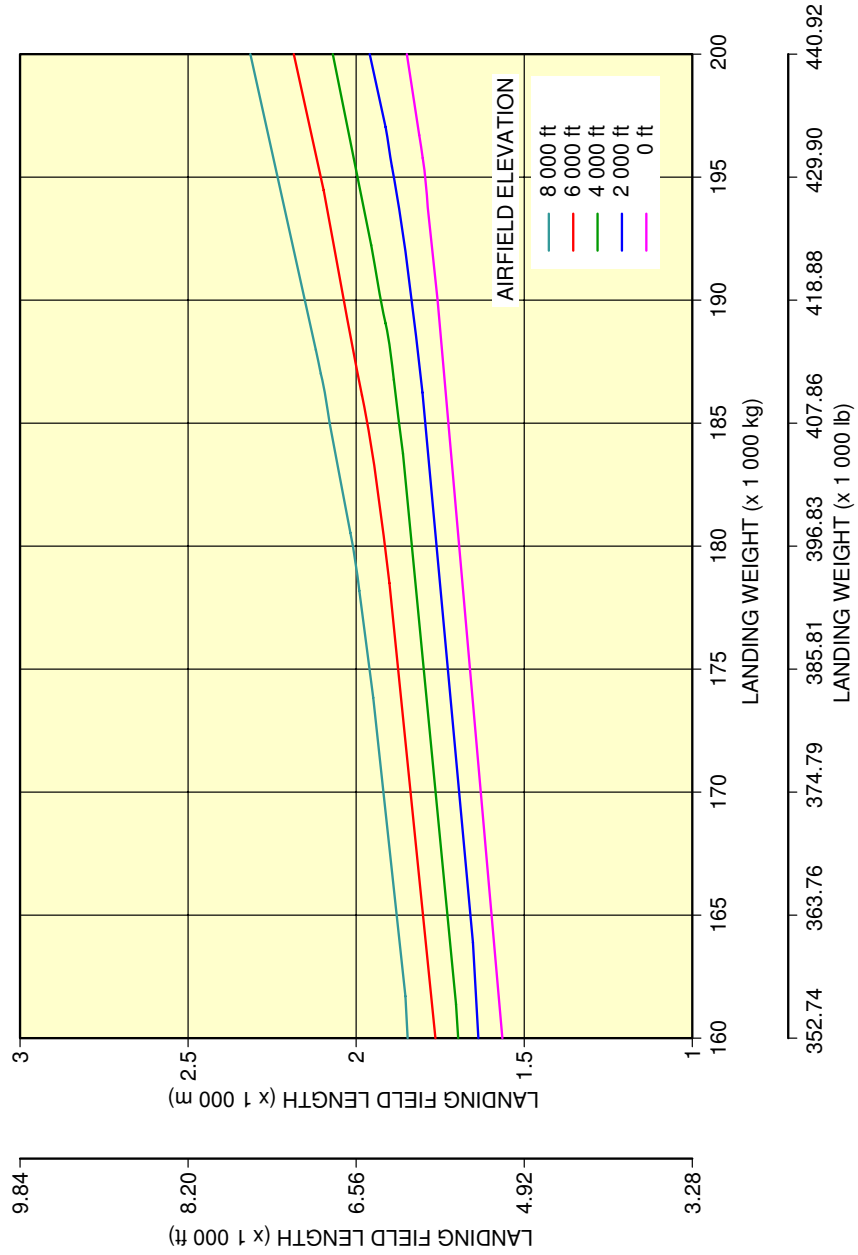

NOTE: THESE CURVES ARE GIVEN FOR INFORMATION ONLY. THE APPROVED VALUES ARE STATED IN THE "OPERATING MANUALS" SPECIFIC TO THE AIRLINE OPERATING THE AIRCRAFT.

F_AC_030401_1_0150101_01_00

Landing Field Length
 ISA Conditions - RR TRENT 700 Series Engine
 FIGURE-3-4-1-991-015-A01

**ON A/C A330-300

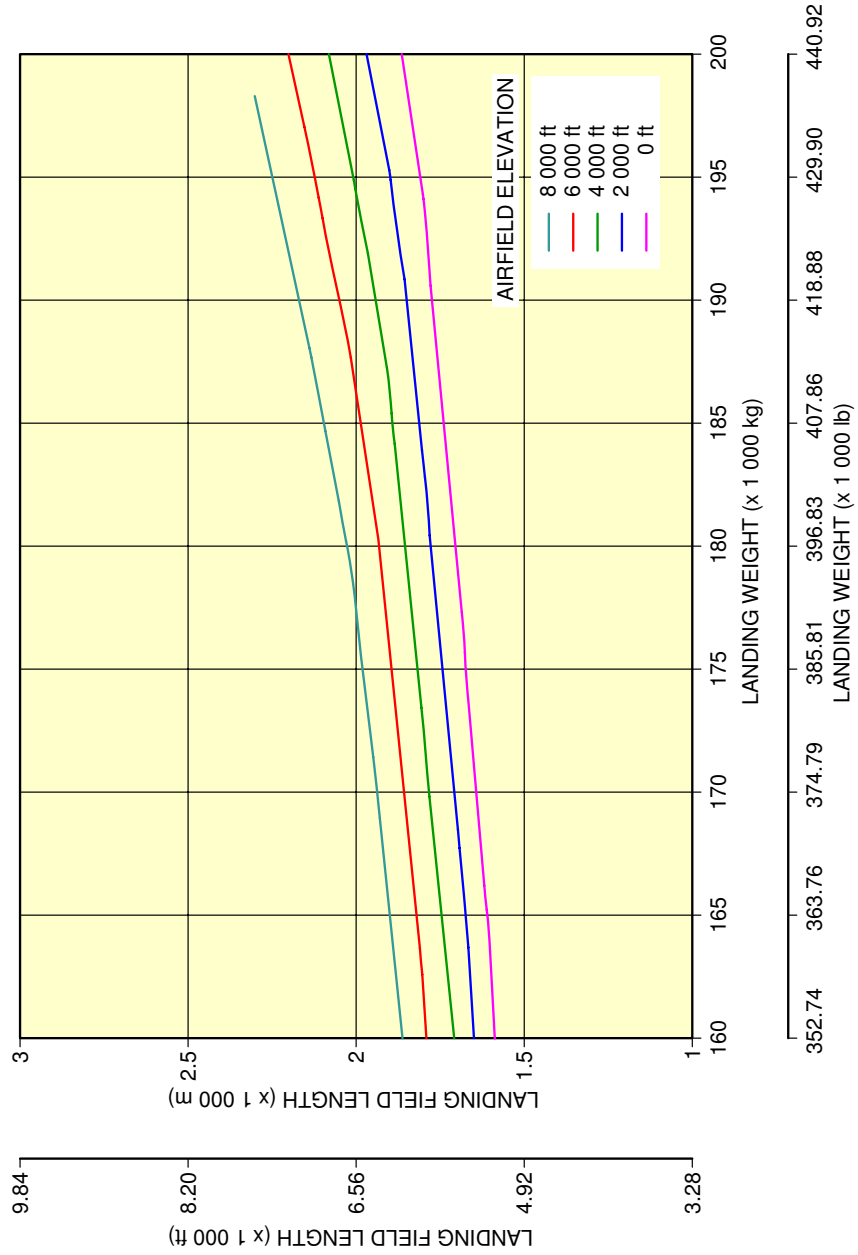

NOTE: THESE CURVES ARE GIVEN FOR INFORMATION ONLY. THE APPROVED VALUES ARE STATED IN THE "OPERATING MANUALS" SPECIFIC TO THE AIRLINE OPERATING THE AIRCRAFT.

F_AC_030401_1_0160101_01_00

Landing Field Length
 ISA Conditions - GE CF6-80E1 Series Engine
 FIGURE-3-4-1-991-016-A01

****ON A/C A330-900**

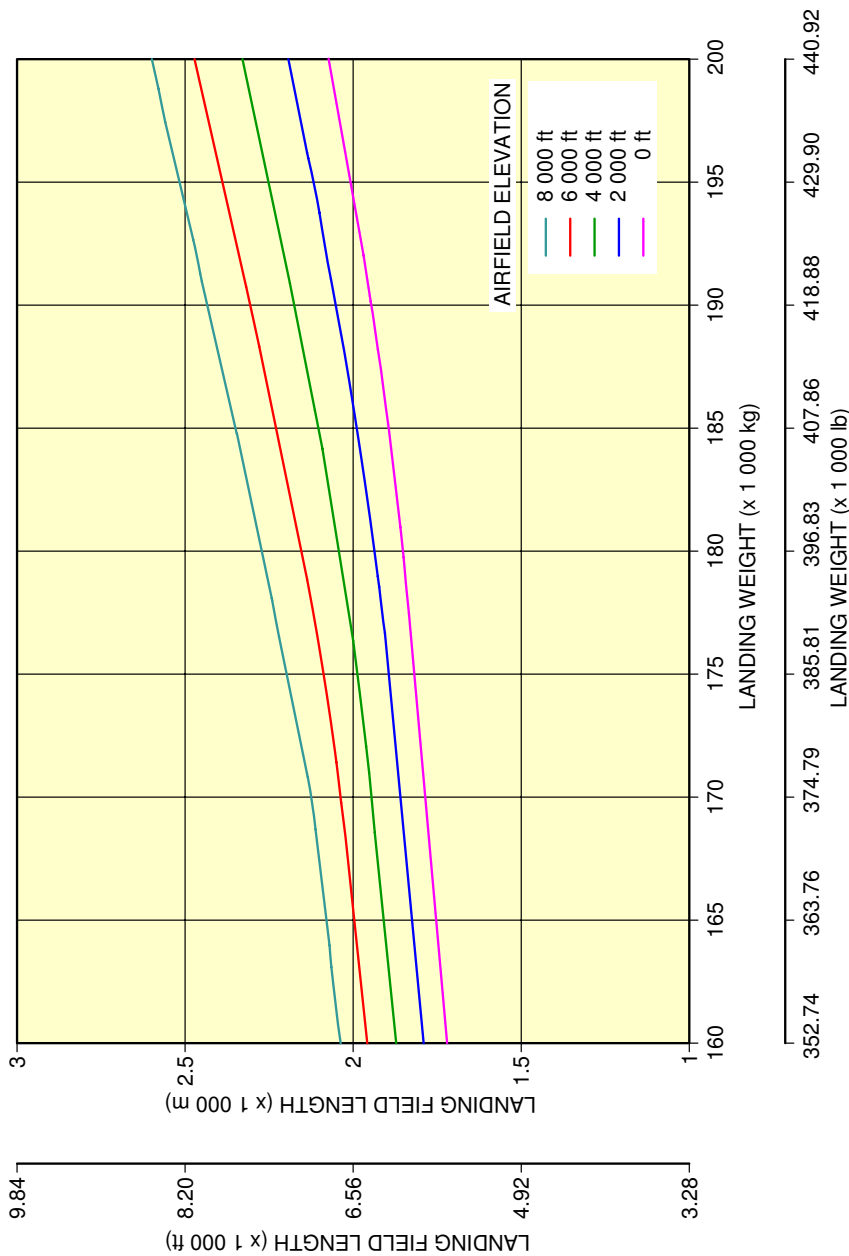

NOTE:
THESE CURVES ARE GIVEN FOR INFORMATION ONLY. THE APPROVED VALUES ARE STATED IN THE "OPERATING MANUALS" SPECIFIC TO THE AIRLINE OPERATING THE AIRCRAFT.

F_AC_030401_1_0170101_01_00

Landing Field Length
ISA Conditions - RR TRENT 7000 Series Engine
FIGURE-3-4-1-991-017-A01

3-5-0 Final Approach Speed****ON A/C A330-200 A330-200F A330-300 A330-800 A330-900**Final Approach Speed****ON A/C A330-200**

1. Final Approach Speed

- A. This section gives the final approach speed. This is the indicated airspeed at threshold in the landing configuration, at the certificated maximum flap setting and maximum landing weight, in standard atmospheric conditions. The approach speed is used to classify the aircraft into an Aircraft Approach Category, a grouping of aircraft based on the indicated airspeed at threshold.
- B. The final approach speed is 136 kt at a Maximum Landing Weight (MLW) of 182 000 kg (401 241 lb) and classifies the aircraft into the Aircraft Approach Category C.

NOTE : This value is given for information only.

****ON A/C A330-200F**

2. Final Approach Speed

- A. This section gives the final approach speed. This is the indicated airspeed at threshold in the landing configuration, at the certificated maximum flap setting and maximum landing weight, in standard atmospheric conditions. The approach speed is used to classify the aircraft into an Aircraft Approach Category, a grouping of aircraft based on the indicated airspeed at threshold.
- B. The final approach speed is 139 kt at a Maximum Landing Weight (MLW) of 187 000 kg (412 264 lb) and classifies the aircraft into the Aircraft Approach Category C.

NOTE : This value is given for information only.

****ON A/C A330-300**

3. Final Approach Speed

- A. This section gives the final approach speed. This is the indicated airspeed at threshold in the landing configuration, at the certificated maximum flap setting and maximum landing weight, in standard atmospheric conditions. The approach speed is used to classify the aircraft into an Aircraft Approach Category, a grouping of aircraft based on the indicated airspeed at threshold.
- B. The final approach speed is 137 kt at a Maximum Landing Weight (MLW) of 187 000 kg (412 264 lb) and classifies the aircraft into the Aircraft Approach Category C.

NOTE : This value is given for information only.

****ON A/C A330-900**

4. Final Approach Speed

- A. This section gives the final approach speed. This is the indicated airspeed at threshold in the landing configuration, at the certificated maximum flap setting and maximum landing weight, in standard atmospheric conditions. The approach speed is used to classify the aircraft into an Aircraft Approach Category, a grouping of aircraft based on the indicated airspeed at threshold.
- B. The final approach speed is 141.9 kt at a Maximum Landing Weight (MLW) of 191 000 kg (421 083 lb) and classifies the aircraft into the Aircraft Approach Category D.

NOTE : This value is given for information only.

****ON A/C A330-800**

5. Final Approach Speed

- A. This section gives the final approach speed. This is the indicated airspeed at threshold in the landing configuration, at the certificated maximum flap setting and maximum landing weight, in standard atmospheric conditions. The approach speed is used to classify the aircraft into an Aircraft Approach Category, a grouping of aircraft based on the indicated airspeed at threshold.
- B. The final approach speed is 139.8 kt at a Maximum Landing Weight (MLW) of 186 000 kg (410 060 lb) and classifies the aircraft into the Aircraft Approach Category C.

NOTE : This value is given for information only.

GROUND MANEUVERING

4-1-0 General Information

****ON A/C A330-200 A330-200F A330-300 A330-800 A330-900**

General Information

1. This section gives aircraft turning capability and maneuvering characteristics.

For ease of presentation, this data has been determined from the theoretical limits imposed by the geometry of the aircraft, and where noted, gives for a normal allowance for tire slippage. As such, it reflects the turning capability of the aircraft in favorable operating circumstances. This data should only be used as guidelines for the method of determination of such parameters and for the maneuvering characteristics of this aircraft type.

In the ground operating mode, varying airline practices may demand that more conservative turning procedures be adopted to avoid excessive tire wear and reduce possible maintenance problems. Airline operating techniques will vary in the level of performance, over a wide range of operating circumstances throughout the world. Variations from standard aircraft operating patterns may be necessary to satisfy physical constraints within the maneuvering area, such as adverse grades, limited area or high risk of jet blast damage. For these reasons, ground maneuvering requirements should be coordinated with the airlines in question prior to layout planning

NOTE : The following chapter takes into account ICAO Annex 14 to the Convention on International Civil Aviation, Aerodromes - Volume I, Aerodrome Design and Operations, Eighth Edition, July 2018.



4-2-0 Turning Radii

**ON A/C A330-200 A330-200F A330-300 A330-800 A330-900

Turning Radii

1. This section gives the turning radii.

**ON A/C A330-200 A330-200F A330-300

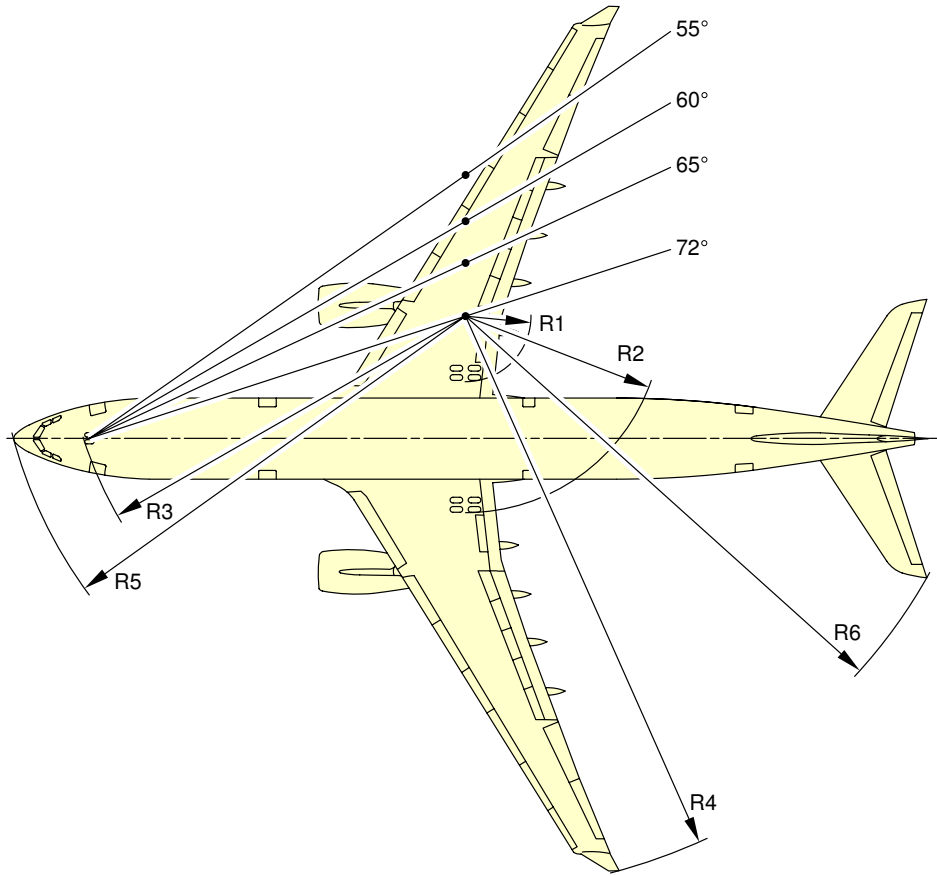

NOTE:
FOR TURNING RADII VALUES, REFER TO SHEET 2.

F_AC_040200_1_0040101_01_04

Turning Radii
(Sheet 1)
FIGURE-4-2-0-991-004-A01

****ON A/C A330-300**

A330-300 TURNING RADII									
TYPE OF TURN	STEERING ANGLE (deg)	EFFECTIVE STEERING ANGLE (deg)		R1 RMLG	R2 LMLG	R3 NLG	R4 WING	R5 NOSE	R6 TAIL
2	20	19.4	m	67.7	78.4	76.9	102.7	78.9	87.7
			ft	222	257	252	337	259	288
2	25	24.2	m	52.1	62.8	62.4	87.1	64.9	73.3
			ft	171	206	205	286	213	241
2	30	29.0	m	41.4	52.1	52.8	76.5	55.9	63.9
			ft	136	171	173	251	183	210
2	35	33.8	m	33.5	44.2	46.1	68.7	49.6	57.2
			ft	110	145	151	225	163	188
2	40	38.6	m	27.4	38.1	41.1	62.7	45.1	52.2
			ft	90	125	135	206	148	171
2	45	43.2	m	22.6	33.3	37.5	58.0	41.9	48.5
			ft	74	109	123	190	138	159
2	50	47.8	m	18.6	29.3	34.6	54.0	39.5	45.5
			ft	61	96	114	177	129	149
2	55	52.2	m	15.3	26.0	32.5	50.7	37.6	43.2
			ft	50	85	106	166	123	142
2	60	56.3	m	12.5	23.2	30.8	48.0	36.2	41.4
			ft	41	76	101	158	119	136
2	65	60.1	m	10.2	20.9	29.6	45.8	35.2	39.9
			ft	34	69	97	150	116	131
2	72	63.8	m	8.1	18.8	28.5	43.7	34.4	38.7
			ft	27	62	94	143	113	127
1	50	48.2	m	18.3	29.0	34.4	53.7	39.3	45.5
			ft	60	95	113	176	129	149
1	55	52.9	m	14.8	25.5	32.2	50.3	37.4	43.2
			ft	49	84	105	165	123	142
1	60	57.6	m	11.7	22.4	30.4	47.2	35.9	41.4
			ft	38	74	100	155	118	136
1	65	62.1	m	9.1	19.7	29.0	44.6	34.7	39.2
			ft	30	65	95	146	114	129
1	72	67.8	m	6.0	16.7	27.6	41.6	33.7	37.5
			ft	20	55	91	137	110	123

NOTE:

ABOVE 50°, AIRLINES MAY USE TYPE 1 OR TYPE 2 TURNS DEPENDING ON THE SITUATION.

TYPE 1 TURNS USE: ASYMMETRIC THRUST DURING THE WHOLE TURN;
AND DIFFERENTIAL BRAKING TO INITIATE THE TURN ONLY.

TYPE 2 TURNS USE: SYMMETRIC THRUST DURING THE WHOLE TURN;
AND NO DIFFERENTIAL BRAKING AT ALL.

IT IS POSSIBLE TO GET LOWER VALUES THAN THOSE FROM TYPE 1 BY APPLYING
DIFFERENTIAL BRAKING DURING THE WHOLE TURN.

F_AC_040200_1_0020101_01_05

Turning Radii
(Sheet 2)
FIGURE-4-2-0-991-002-A01

****ON A/C A330-200 A330-200F**

A330-200/-200F TURNING RADII									
TYPE OF TURN	STEERING ANGLE (deg)	EFFECTIVE STEERING ANGLE (deg)		R1 RMLG	R2 LMLG	R3 NLG	R4 WING	R5 NOSE	R6 TAIL
2	20	19.2	m	59.3	70.0	68.0	94.4	69.9	79.1
			ft	195	230	223	310	229	260
2	25	23.9	m	45.7	56.4	55.3	80.9	57.8	66.6
			ft	150	185	181	265	190	219
2	30	28.6	m	36.3	47.0	46.8	71.6	49.9	58.4
			ft	119	154	154	235	164	192
2	35	33.3	m	29.4	40.1	40.9	64.7	44.4	52.5
			ft	96	132	134	212	146	172
2	40	38.0	m	24.0	34.7	36.5	59.4	40.5	48.2
			ft	79	114	120	195	133	158
2	45	42.5	m	19.8	30.5	33.2	55.3	37.7	45.0
			ft	65	100	109	181	124	148
2	50	46.9	m	16.4	27.1	30.8	51.9	35.5	42.4
			ft	54	89	101	170	116	139
2	55	51.2	m	13.5	24.1	28.8	49.1	33.9	40.4
			ft	44	79	94	161	111	133
2	60	55.1	m	11.1	21.8	27.4	46.8	32.7	38.8
			ft	36	72	90	154	107	127
2	65	59.6	m	8.6	19.3	26.0	44.4	31.6	37.2
			ft	28	63	85	146	104	122
2	72	62.0	m	7.4	18.1	25.4	43.2	31.2	36.5
			ft	24	59	83	142	102	120
1	50	48.4	m	15.3	26.0	30.0	50.9	34.9	41.7
			ft	50	85	98	167	115	137
1	55	52.2	m	12.8	23.5	28.4	48.5	33.6	39.9
			ft	42	77	93	159	110	131
1	60	57.7	m	9.6	20.3	26.5	45.4	32.1	37.9
			ft	31	67	87	149	105	124
1	65	62.2	m	7.3	18.0	25.3	43.1	31.1	36.5
			ft	24	59	83	141	102	120
1	72	68.1	m	4.5	15.2	24.1	40.4	30.2	34.9
			ft	15	50	79	133	99	115

NOTE:

ABOVE 50°, AIRLINES MAY USE TYPE 1 OR TYPE 2 TURNS DEPENDING ON THE SITUATION.

TYPE 1 TURNS USE: ASYMMETRIC THRUST DURING THE WHOLE TURN;
AND DIFFERENTIAL BRAKING TO INITIATE THE TURN ONLY.

TYPE 2 TURNS USE: SYMMETRIC THRUST DURING THE WHOLE TURN;
AND NO DIFFERENTIAL BRAKING AT ALL.

IT IS POSSIBLE TO GET LOWER VALUES THAN THOSE FROM TYPE 1 BY APPLYING DIFFERENTIAL BRAKING DURING THE WHOLE TURN.

F_AC_040200_1_0030101_01_05

Turning Radii
(Sheet 2)
FIGURE-4-2-0-991-003-A01

**ON A/C A330-800 A330-900

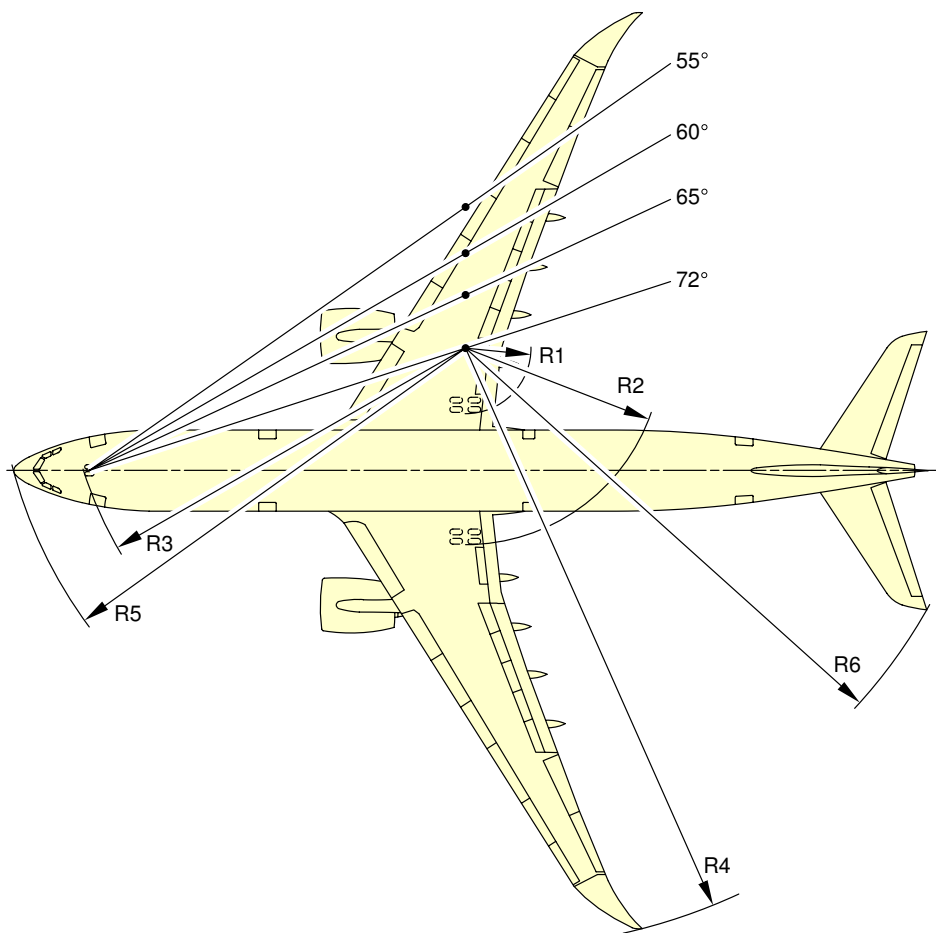

NOTE:
FOR TURNING RADII VALUES, REFER TO SHEET 2.

F_AC_040200_1_0140101_01_01

Turning Radii
(Sheet 1)
FIGURE-4-2-0-991-014-A01

****ON A/C A330-900**

A330-900 TURNING RADII									
TYPE OF TURN	STEERING ANGLE (deg)	EFFECTIVE STEERING ANGLE (deg)		R1 RMLG	R2 LMLG	R3 NLG	R4 WING	R5 NOSE	R6 TAIL
2	20	19.4	m	67.7	78.4	76.9	104.7	78.9	87.7
			ft	222	257	252	344	259	288
2	25	24.2	m	52.1	62.8	62.4	89.3	64.9	73.3
			ft	171	206	205	293	213	241
2	30	29.0	m	41.4	52.1	52.8	78.7	55.9	63.9
			ft	136	171	173	258	183	210
2	35	33.8	m	33.5	44.2	46.1	70.9	49.6	57.2
			ft	110	145	151	233	163	188
2	40	38.6	m	27.4	38.1	41.1	64.9	45.1	52.2
			ft	90	125	135	213	148	171
2	45	43.2	m	22.6	33.3	37.5	60.2	41.9	48.5
			ft	74	109	123	198	138	159
2	50	47.8	m	18.6	29.3	34.6	56.3	39.5	45.5
			ft	61	96	114	185	129	149
2	55	52.2	m	15.3	26.0	32.5	53.0	37.6	43.2
			ft	50	85	106	174	123	142
2	60	56.3	m	12.5	23.2	30.8	50.4	36.2	41.4
			ft	41	76	101	165	119	136
2	65	60.1	m	10.2	20.9	29.6	48.1	35.2	39.9
			ft	34	69	97	158	116	131
2	72	63.8	m	8.1	18.8	28.5	46.1	34.4	38.7
			ft	27	62	94	151	113	127
1	50	48.2	m	18.3	29.0	34.4	56.0	39.3	45.5
			ft	60	95	113	184	129	149
1	55	52.9	m	14.8	25.5	32.2	52.6	37.4	43.2
			ft	49	84	105	172	123	142
1	60	57.6	m	11.7	22.4	30.4	49.6	35.9	41.4
			ft	38	74	100	163	118	136
1	65	62.1	m	9.1	19.7	29.0	47.0	34.7	39.2
			ft	30	65	95	154	114	129
1	72	67.8	m	6.0	16.7	27.6	44.0	33.7	37.5
			ft	20	55	91	144	110	123

NOTE:

ABOVE 50°, AIRLINES MAY USE TYPE 1 OR TYPE 2 TURNS DEPENDING ON THE SITUATION.

TYPE 1 TURNS USE: ASYMMETRIC THRUST DURING THE WHOLE TURN;
AND DIFFERENTIAL BRAKING TO INITIATE THE TURN ONLY.

TYPE 2 TURNS USE: SYMMETRIC THRUST DURING THE WHOLE TURN;
AND NO DIFFERENTIAL BRAKING AT ALL.

IT IS POSSIBLE TO GET LOWER VALUES THAN THOSE FROM TYPE 1 BY APPLYING DIFFERENTIAL BRAKING DURING THE WHOLE TURN.

F_AC_040200_1_0150101_01_01

Turning Radii
(Sheet 2)
FIGURE-4-2-0-991-015-A01

****ON A/C A330-800**

A330-800 TURNING RADII									
TYPE OF TURN	STEERING ANGLE (deg)	EFFECTIVE STEERING ANGLE (deg)		R1 RMLG	R2 LMLG	R3 NLG	R4 WING	R5 NOSE	R6 TAIL
2	20	19.2	m	59.3	70.0	68.0	96.4	69.9	79.1
			ft	195	230	223	316	229	260
2	25	23.9	m	45.7	56.4	55.3	82.9	57.8	66.6
			ft	150	185	181	272	190	219
2	30	28.6	m	36.3	47.0	46.8	73.7	49.9	58.4
			ft	119	154	154	242	164	192
2	35	33.3	m	29.4	40.1	40.9	66.8	44.4	52.5
			ft	96	131	134	219	146	172
2	40	38.0	m	24.0	34.7	36.5	61.6	40.5	48.2
			ft	79	114	120	202	133	158
2	45	42.5	m	19.8	30.5	33.2	57.5	37.7	45.0
			ft	65	100	109	188	124	147
2	50	46.9	m	16.4	27.1	30.8	54.1	35.5	42.4
			ft	54	89	101	177	117	139
2	55	51.2	m	13.5	24.1	28.8	51.2	33.9	40.4
			ft	44	79	95	168	111	132
2	60	55.1	m	11.1	21.8	27.4	48.9	32.7	38.8
			ft	36	71	90	161	107	127
2	65	59.6	m	8.6	19.3	26.0	46.6	31.6	37.2
			ft	28	63	85	153	104	122
2	72	62.0	m	7.4	18.1	25.4	45.4	31.2	36.5
			ft	24	59	83	149	102	120
1	50	48.4	m	15.3	26.0	30.0	53.0	34.9	41.7
			ft	50	85	99	174	115	137
1	55	52.2	m	12.8	23.5	28.4	50.6	33.6	39.9
			ft	42	77	93	166	110	131
1	60	57.7	m	9.6	20.3	26.5	47.5	32.1	37.9
			ft	32	67	87	156	105	124
1	65	62.2	m	7.3	18.0	25.3	45.3	31.1	36.5
			ft	24	59	83	149	102	120
1	72	68.1	m	4.5	15.2	24.1	42.6	30.2	34.9
			ft	15	50	79	140	99	114

NOTE:

ABOVE 50°, AIRLINES MAY USE TYPE 1 OR TYPE 2 TURNS DEPENDING ON THE SITUATION.

TYPE 1 TURNS USE: ASYMMETRIC THRUST DURING THE WHOLE TURN;
AND DIFFERENTIAL BRAKING TO INITIATE THE TURN ONLY.

TYPE 2 TURNS USE: SYMMETRIC THRUST DURING THE WHOLE TURN;
AND NO DIFFERENTIAL BRAKING AT ALL.

IT IS POSSIBLE TO GET LOWER VALUES THAN THOSE FROM TYPE 1 BY
APPLYING DIFFERENTIAL BRAKING DURING THE WHOLE TURN.

F_AC_040200_1_0160101_01_01

Turning Radii
(Sheet 2)
FIGURE-4-2-0-991-016-A01



4-3-0 Minimum Turning Radii

**ON A/C A330-200 A330-200F A330-300 A330-800 A330-900

Minimum Turning Radii

1. This section gives the minimum turning radii.

****ON A/C A330-300**

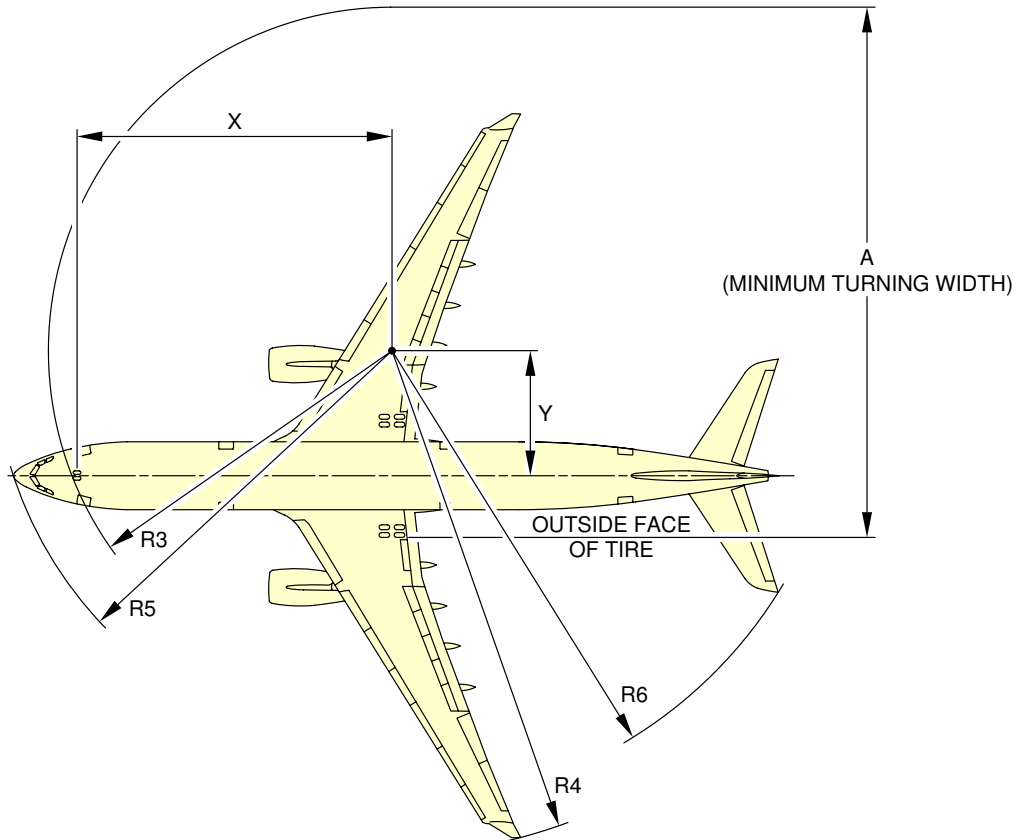

A330-300 MINIMUM TURNING RADII										
TYPE OF TURN	STEERING ANGLE (deg)	EFFECTIVE STEERING ANGLE (deg)			A	R3 NLG	R4 WING	R5 NOSE	R6 TAIL	
			X	Y						
1	72 (MAX)	67.8	m	25.4	10.4	44.6	27.6	41.6	33.7	37.5
			ft	83	34	146	91	137	110	123
2	72 (MAX)	63.8	m	25.4	12.5	47.6	28.5	43.7	34.4	38.7
			ft	83	41	156	94	143	113	127
1	65 (MAX)	62.1	m	25.4	13.4	49.0	29.0	44.6	34.7	39.2
			ft	83	44	161	95	146	114	129
2	65 (MAX)	60.1	m	25.4	14.6	50.7	29.6	45.8	35.2	39.9
			ft	83	48	166	97	150	116	131

NOTE:

TYPE 1 TURNS USE: ASYMMETRIC THRUST DURING THE WHOLE TURN;
AND DIFFERENTIAL BRAKING TO INITIATE THE TURN ONLY.

TYPE 2 TURNS USE: SYMMETRIC THRUST DURING THE WHOLE TURN;
AND NO DIFFERENTIAL BRAKING AT ALL.

IT IS POSSIBLE TO GET LOWER VALUES THAN THOSE FROM TYPE 1 BY APPLYING DIFFERENTIAL BRAKING DURING THE WHOLE TURN.

F_AC_040300_1_0010101_01_06

Minimum Turning Radii
FIGURE-4-3-0-991-001-A01

****ON A/C A330-200 A330-200F**

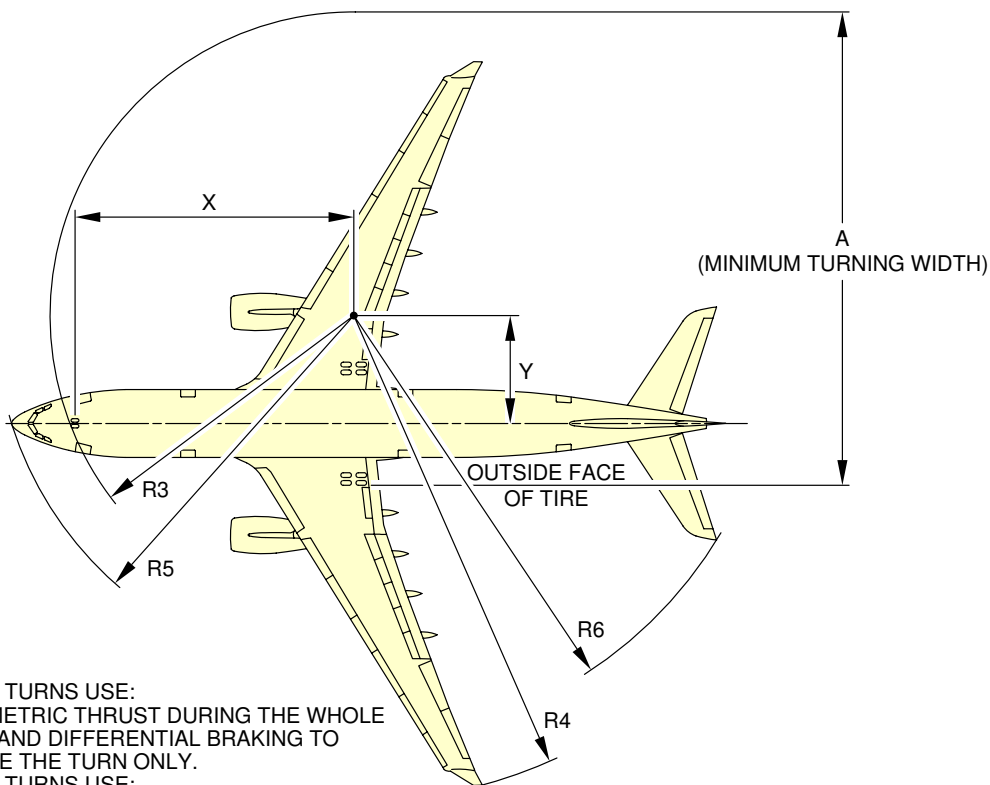

NOTE:
 TYPE 1 TURNS USE:
 ASYMMETRIC THRUST DURING THE WHOLE TURN; AND DIFFERENTIAL BRAKING TO INITIATE THE TURN ONLY.
 TYPE 2 TURNS USE:
 SYMMETRIC THRUST DURING THE WHOLE TURN; AND NO DIFFERENTIAL BRAKING AT ALL.

A330-200/-200F MINIMUM TURNING RADII										
TYPE OF TURN	STEERING ANGLE (deg)	EFFECTIVE STEERING ANGLE (deg)		X	Y	A	R3 NLG	R4 WING	R5 NOSE	R6 TAIL
1	72 (MAX)	68.1	m	22.2	8.9	39.7	24.1	40.4	30.2	34.9
			ft	73	29	130	79	133	99	115
2	72 (MAX)	62.0	m	22.2	11.8	43.8	25.4	43.2	31.2	36.5
			ft	73	39	144	83	142	102	120
1	65 (MAX)	62.2	m	22.2	11.7	43.6	25.3	43.1	31.1	36.5
			ft	73	38	143	83	141	102	120
2	65 (MAX)	59.6	m	22.2	13.0	45.6	26.0	44.4	31.6	37.2
			ft	73	43	150	85	146	104	122

NOTE:
 IT IS POSSIBLE TO GET LOWER VALUES THAN THOSE FROM TYPE 1 BY APPLYING DIFFERENTIAL BRAKING DURING THE WHOLE TURN.

F_AC_040300_1_0070101_01_01

Minimum Turning Radii
 FIGURE-4-3-0-991-007-A01

****ON A/C A330-900**

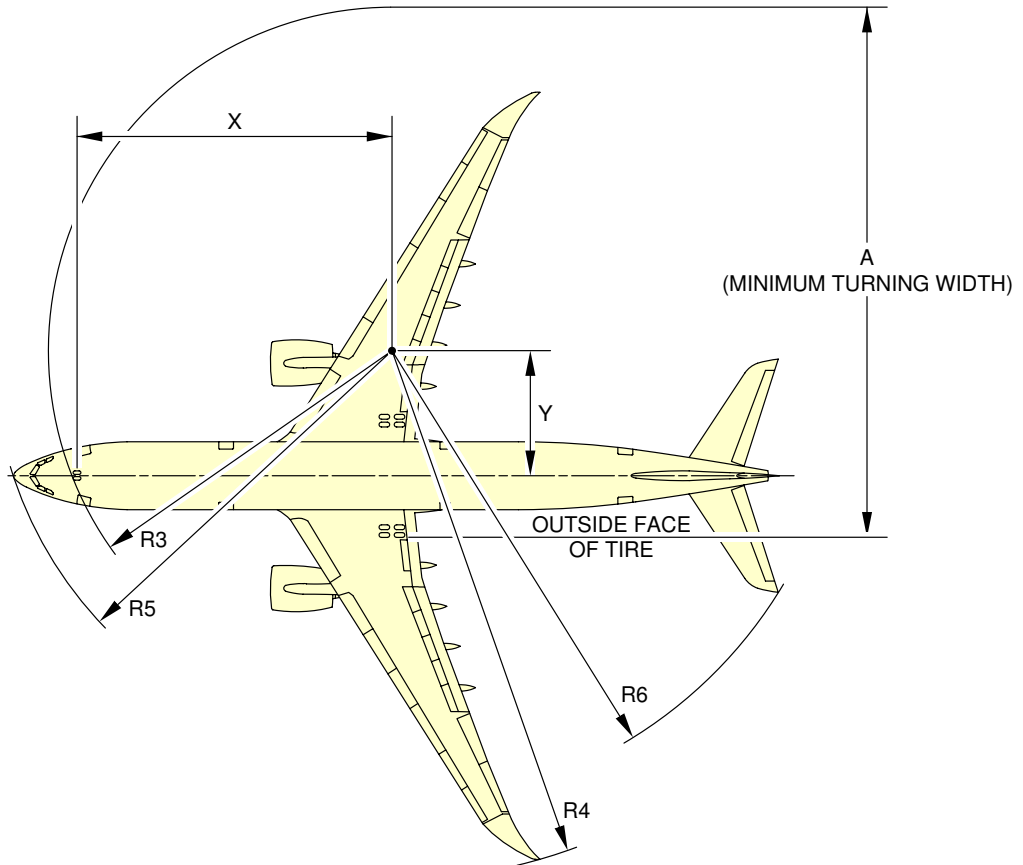

A330-900 MINIMUM TURNING RADII										
TYPE OF TURN	STEERING ANGLE (deg)	EFFECTIVE STEERING ANGLE (deg)		X	Y	A	R3 NLG	R4 WING	R5 NOSE	R6 TAIL
1	72 (MAX)	67.8	m	25.4	10.4	44.6	27.6	44.0	33.7	37.5
			ft	83	34	146	91	144	110	123
2	72 (MAX)	63.8	m	25.4	12.5	47.6	28.5	46.1	34.4	38.7
			ft	83	41	156	94	151	113	127

NOTE:

TYPE 1 TURNS USE: ASYMMETRIC THRUST DURING THE WHOLE TURN;
AND DIFFERENTIAL BRAKING TO INITIATE THE TURN ONLY.

TYPE 2 TURNS USE: SYMMETRIC THRUST DURING THE WHOLE TURN;
AND NO DIFFERENTIAL BRAKING AT ALL.

IT IS POSSIBLE TO GET LOWER VALUES THAN THOSE FROM TYPE 1 BY
APPLYING DIFFERENTIAL BRAKING DURING THE WHOLE TURN.

F_AC_040300_1_0080101_01_01

Minimum Turning Radii
FIGURE-4-3-0-991-008-A01

****ON A/C A330-800**

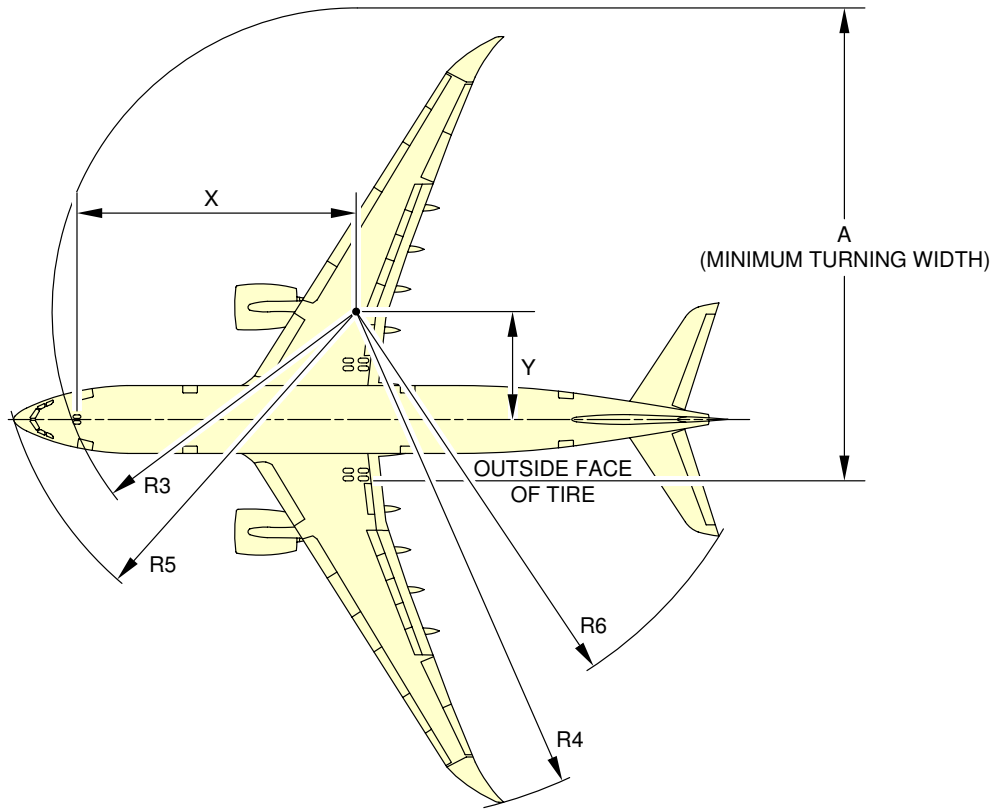

A330-800 MINIMUM TURNING RADII										
TYPE OF TURN	STEERING ANGLE (deg)	EFFECTIVE STEERING ANGLE (deg)		X	Y	A	R3 NLG	R4 WING	R5 NOSE	R6 TAIL
1	72 (MAX)	68.1	m	22.2	8.9	39.7	24.1	42.6	30.2	34.9
			ft	73	29	130	79	140	99	114
2	72 (MAX)	62.0	m	22.2	11.8	43.8	25.4	45.4	31.2	36.5
			ft	73	39	144	83	149	102	120

NOTE:

TYPE 1 TURNS USE: ASYMMETRIC THRUST DURING THE WHOLE TURN;
AND DIFFERENTIAL BRAKING TO INITIATE THE TURN ONLY.

TYPE 2 TURNS USE: SYMMETRIC THRUST DURING THE WHOLE TURN;
AND NO DIFFERENTIAL BRAKING AT ALL.

IT IS POSSIBLE TO GET LOWER VALUES THAN THOSE FROM TYPE 1 BY
APPLYING DIFFERENTIAL BRAKING DURING THE WHOLE TURN.

F_AC_040300_1_0090101_01_01

Minimum Turning Radii
FIGURE-4-3-0-991-009-A01



4-4-0 Visibility from Cockpit in Static Position

****ON A/C A330-200 A330-200F A330-300 A330-800 A330-900**

Visibility from Cockpit in Static Position.

1. This section gives the visibility from cockpit in static position.

**ON A/C A330-200 A330-300 A330-800 A330-900

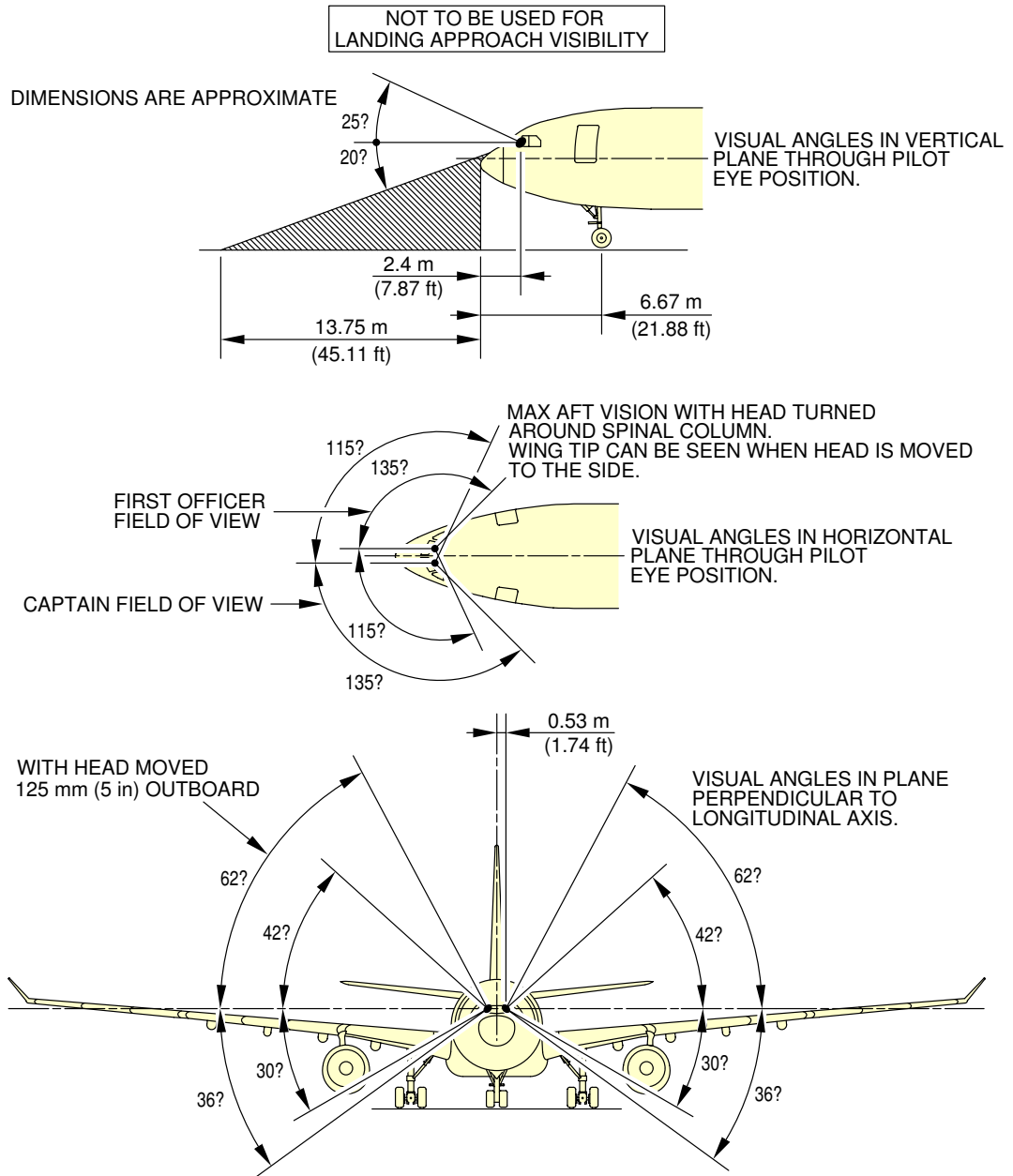

NOTE:

- PILOT EYE POSITION WHEN PILOT'S EYES ARE IN LINE WITH THE RED AND WHITE BALLS.

ZONE THAT CANNOT BE SEEN

F_AC_040400_1_0010101_01_02

Visibility from Cockpit in Static Position
FIGURE-4-4-0-991-001-A01

****ON A/C A330-200F**

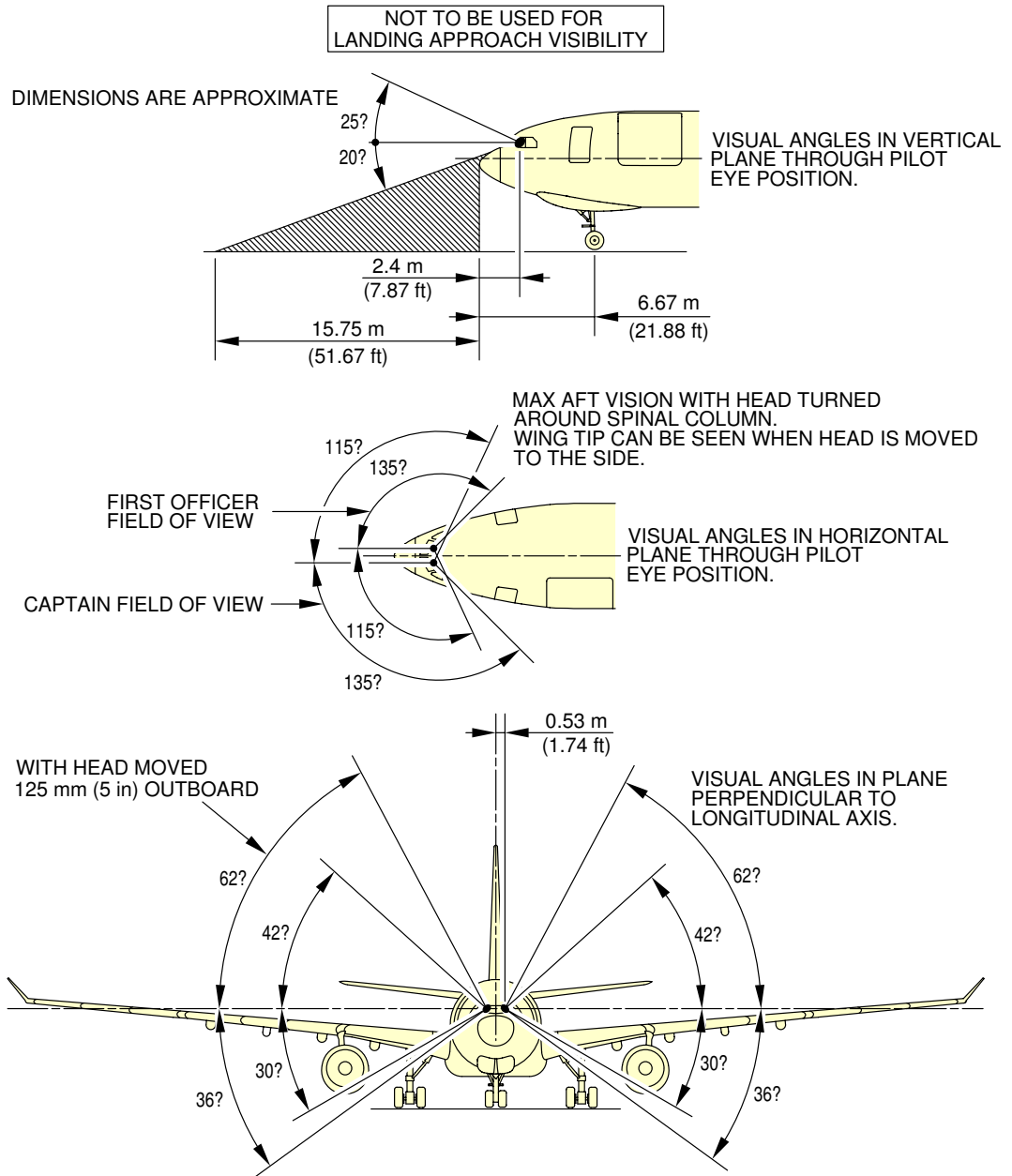

NOTE:

- PILOT EYE POSITION WHEN PILOT'S EYES ARE IN LINE WITH THE RED AND WHITE BALLS.

ZONE THAT CANNOT BE SEEN

F_AC_040400_1_0030101_01_02

Visibility from Cockpit in Static Position
FIGURE-4-4-0-991-003-A01

**ON A/C A330-200 A330-200F A330-300 A330-800 A330-900

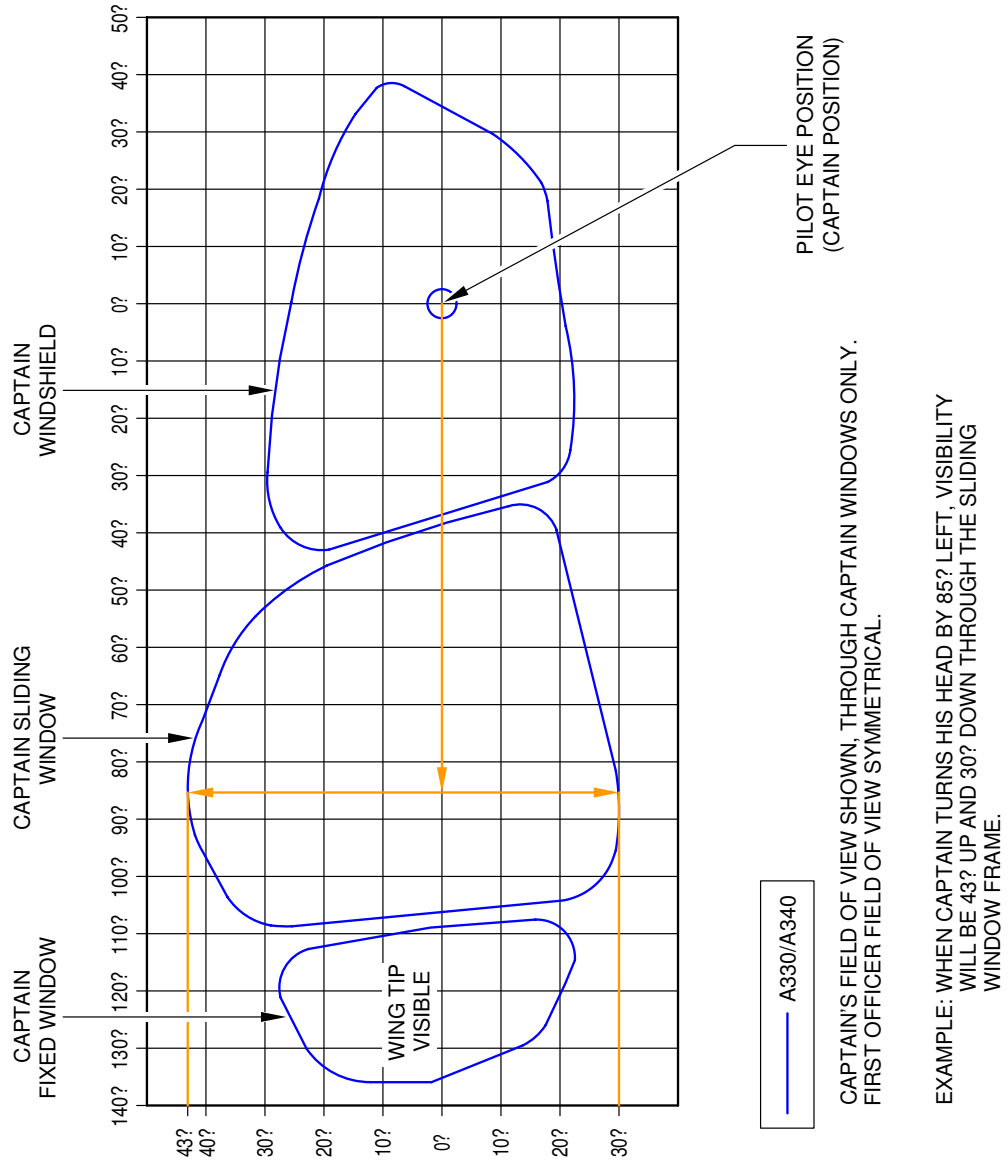

F_AC_040400_1_0060101_01_00

Binocular Visibility Through Windows from Captain Eye Position
FIGURE-4-4-0-991-006-A01

4-5-0 Runway and Taxiway Turn Paths

****ON A/C A330-200 A330-200F A330-300 A330-800 A330-900**

Runway and Taxiway Turn Paths

1. This section gives the runway and taxiway turn paths for the following configurations:

- 135° Turn - Runway to Taxiway
- 90° Turn - Runway to Taxiway
- 180° Turn on a Runway
- 135° Turn - Taxiway to Taxiway
- 90° Turn - Taxiway to Taxiway.

The turn paths Runway to Taxiway and Taxiway to Taxiway are defined using 2 methods:

- Oversteering method,
- Cockpit over centerline method.

The 180° Turn on runway is defined using the following method:

- 180° Turn using edge of runway method.

NOTE : The fillet design and the turn radii are as per FAA AC 150/5300-13 Change 18.



4-5-1 135° Turn - Runway to Taxiway

****ON A/C A330-200 A330-200F A330-300 A330-800 A330-900**

135° Turn - Runway to Taxiway

1. This section gives the 135° turn - runway to taxiway.

**ON A/C A330-300 A330-900

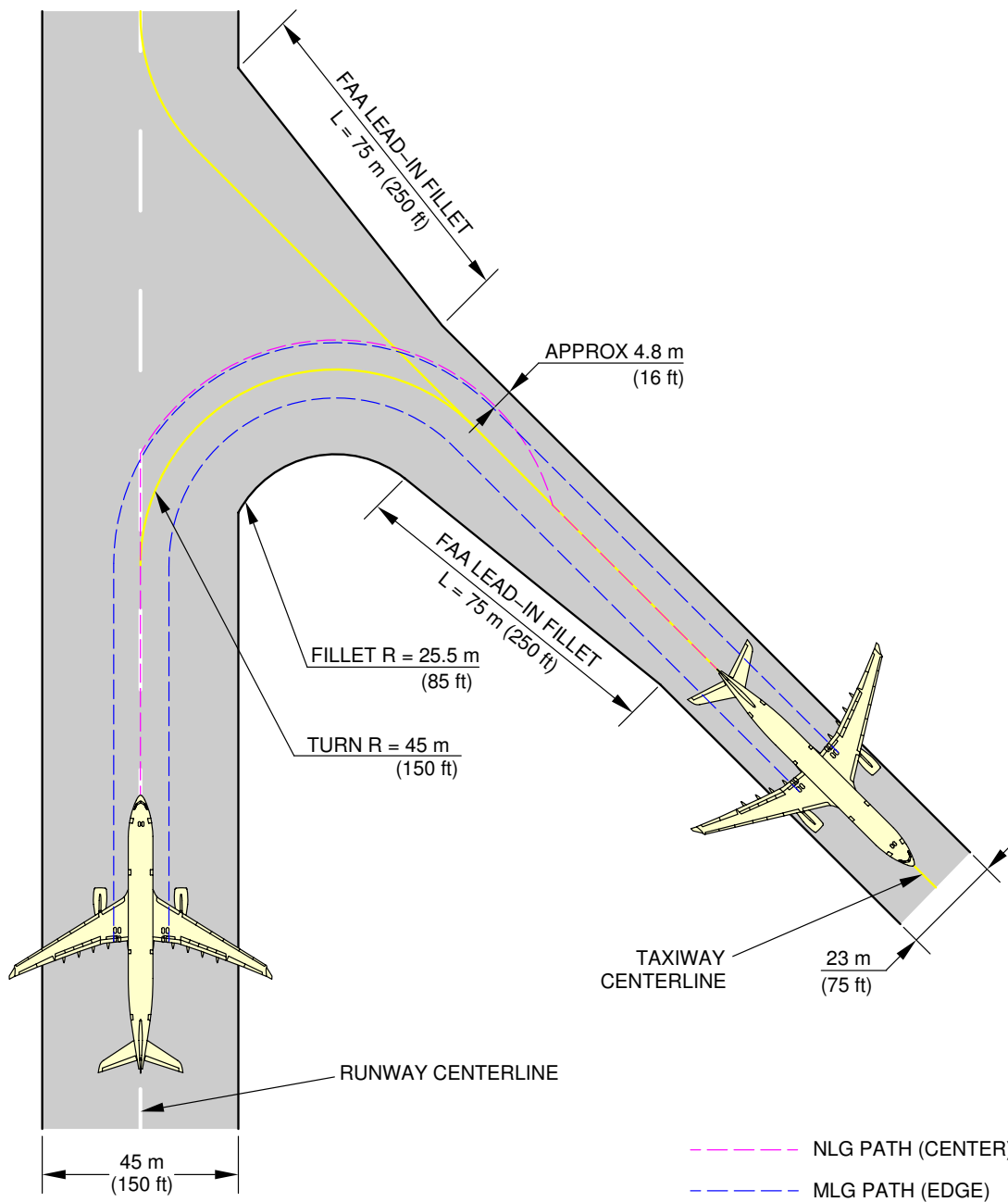

NOTE:
 THE MLG FOLLOWS THE CENTERLINE.
 THE NLG EDGE MARGIN DECREASES BY 0.5 m (2 ft).

F_AC_040501_1_0010101_01_02

135° Turn - Runway to Taxiway
 Judgemental Oversteering Method
 FIGURE-4-5-1-991-001-A01

**ON A/C A330-300 A330-900

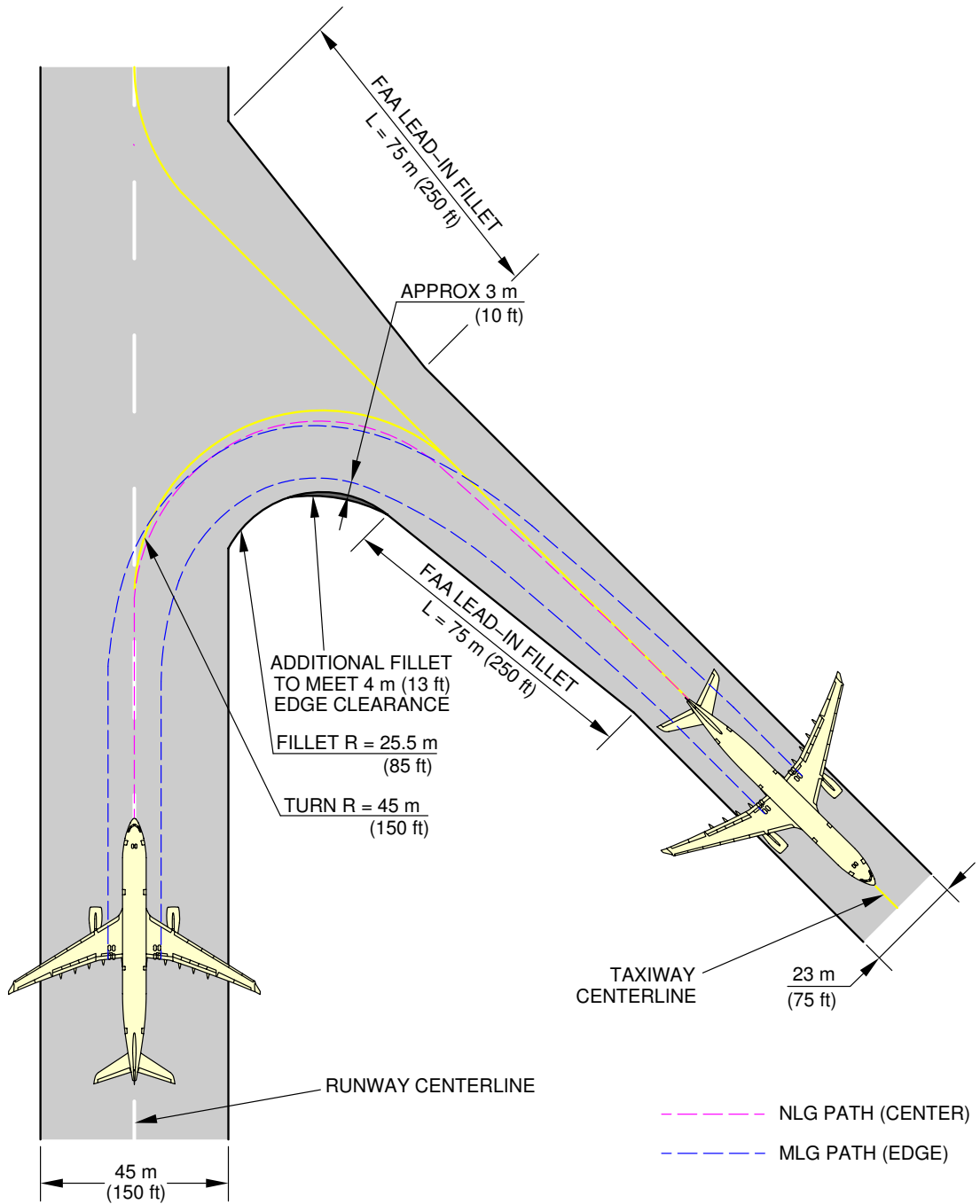

F_AC_040501_1_0060101_01_01

135° Turn - Runway to Taxiway
Cockpit Over Centerline Method
FIGURE-4-5-1-991-006-A01

**ON A/C A330-200 A330-200F A330-800

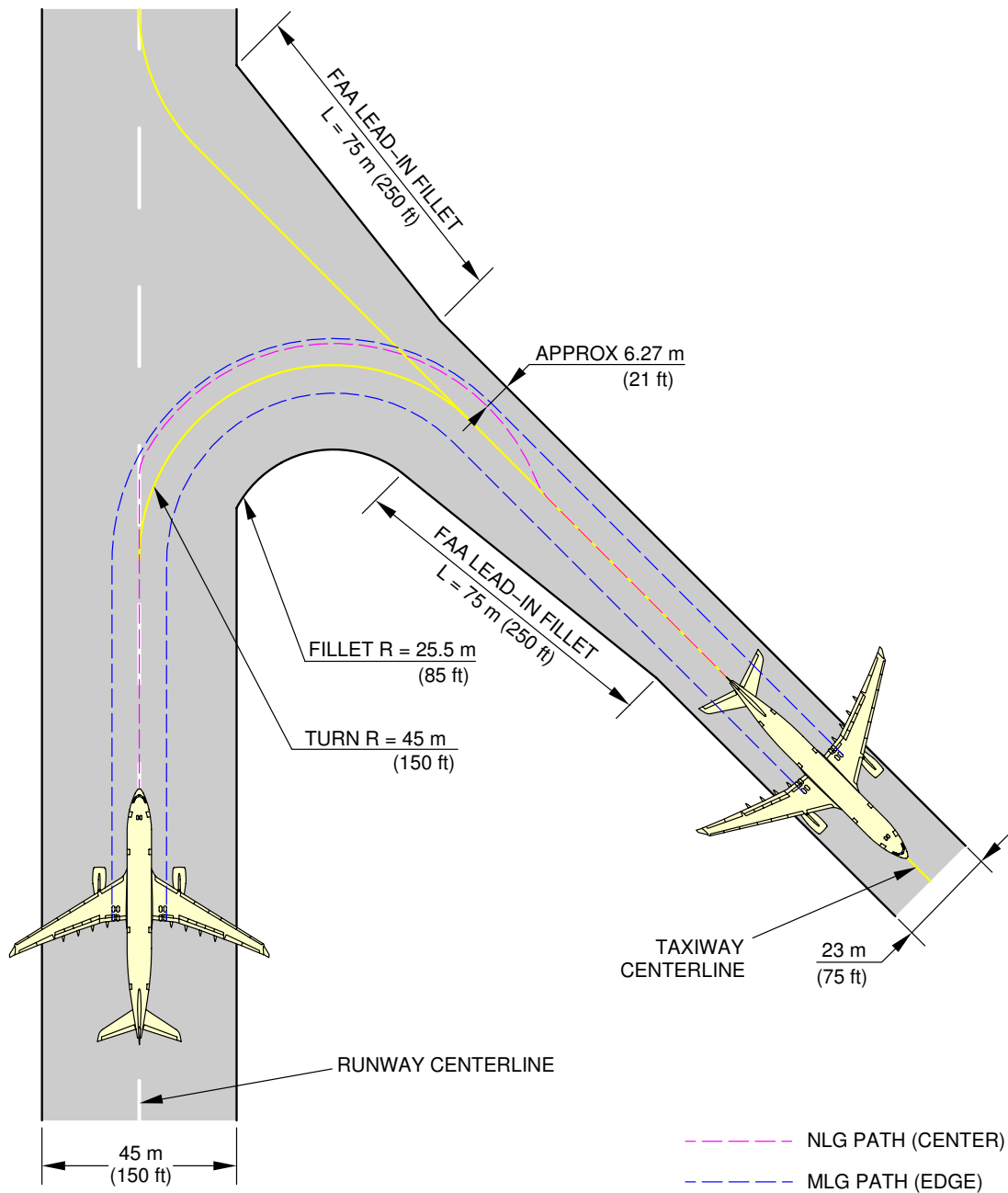

NOTE:
THE MLG FOLLOWS THE CENTERLINE.
THE NLG EDGE MARGIN DECREASES BY 0.5 m (2 ft).

F_AC_040501_1_0020101_01_02

135° Turn - Runway to Taxiway
Judgemental Oversteering Method
FIGURE-4-5-1-991-002-A01

**ON A/C A330-200 A330-200F A330-800

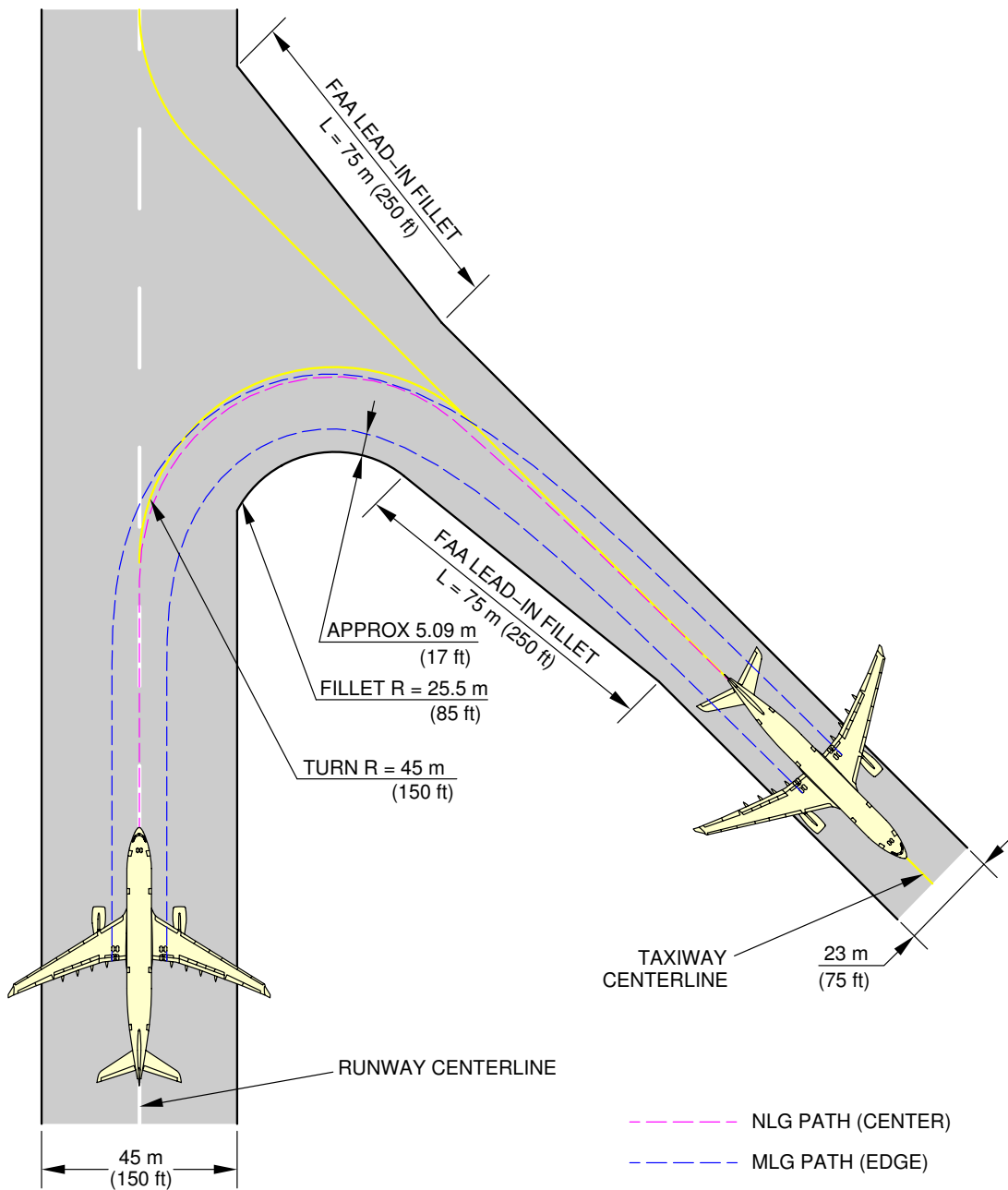

F_AC_040501_1_0070101_01_01

135° Turn - Runway to Taxiway
Cockpit Over Centerline Method
FIGURE-4-5-1-991-007-A01



4-5-2 90° Turn - Runway to Taxiway

****ON A/C A330-200 A330-200F A330-300 A330-800 A330-900**

90° Turn - Runway to Taxiway

1. This section gives the 90° turn - runway to taxiway.

**ON A/C A330-300 A330-900

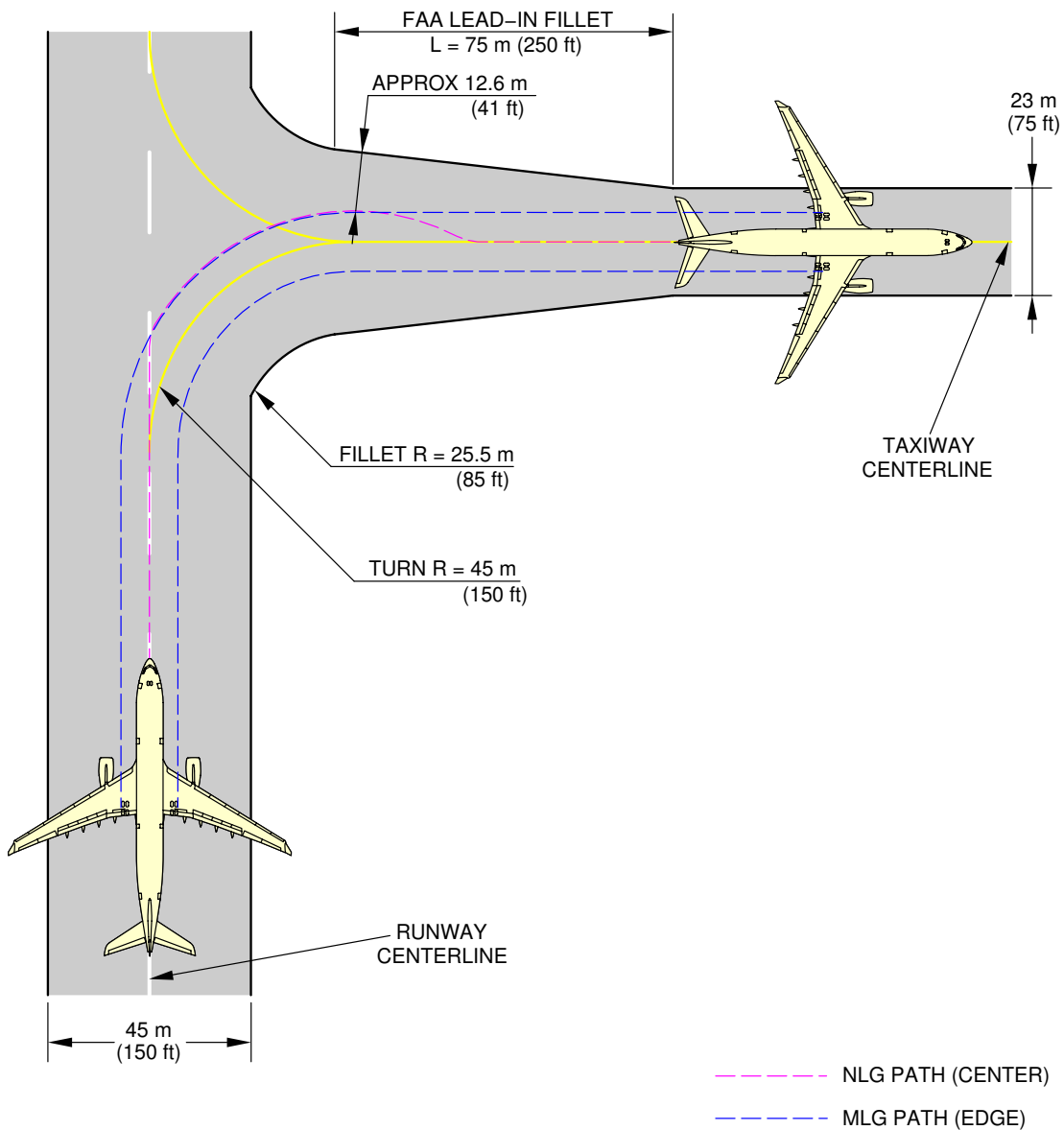

NOTE:
THE MLG FOLLOWS THE CENTERLINE.
THE NLG EDGE MARGIN DECREASES BY 0.5 m (2 ft).

F_AC_040502_1_0010101_01_02

90° Turn - Runway to Taxiway
Judgemental Oversteering Method
FIGURE-4-5-2-991-001-A01

**ON A/C A330-300 A330-900

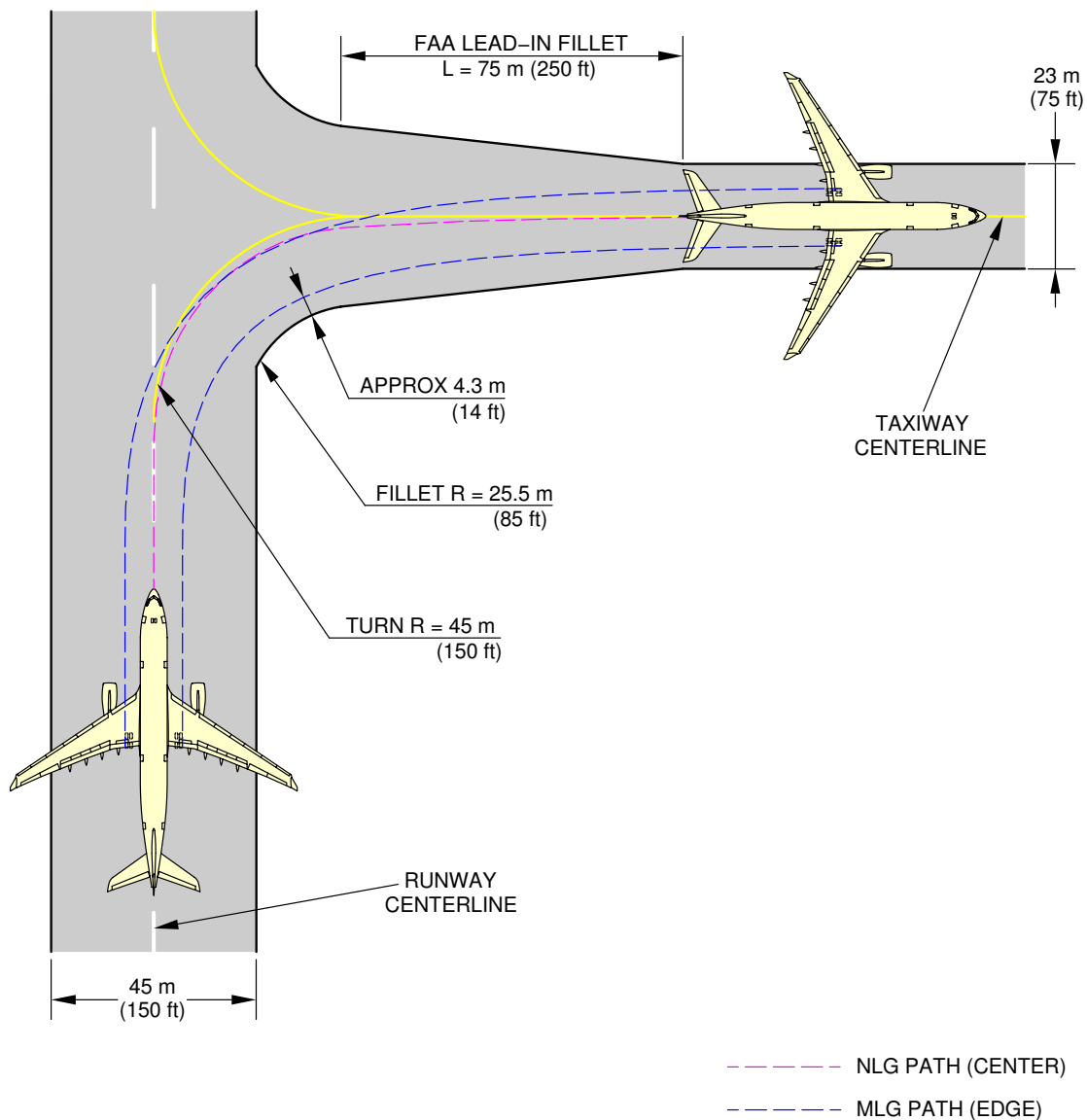

F_AC_040502_1_0080101_01_01

90° Turn - Runway to Taxiway
Cockpit Over Centerline Method
FIGURE-4-5-2-991-008-A01

**ON A/C A330-200 A330-200F A330-800

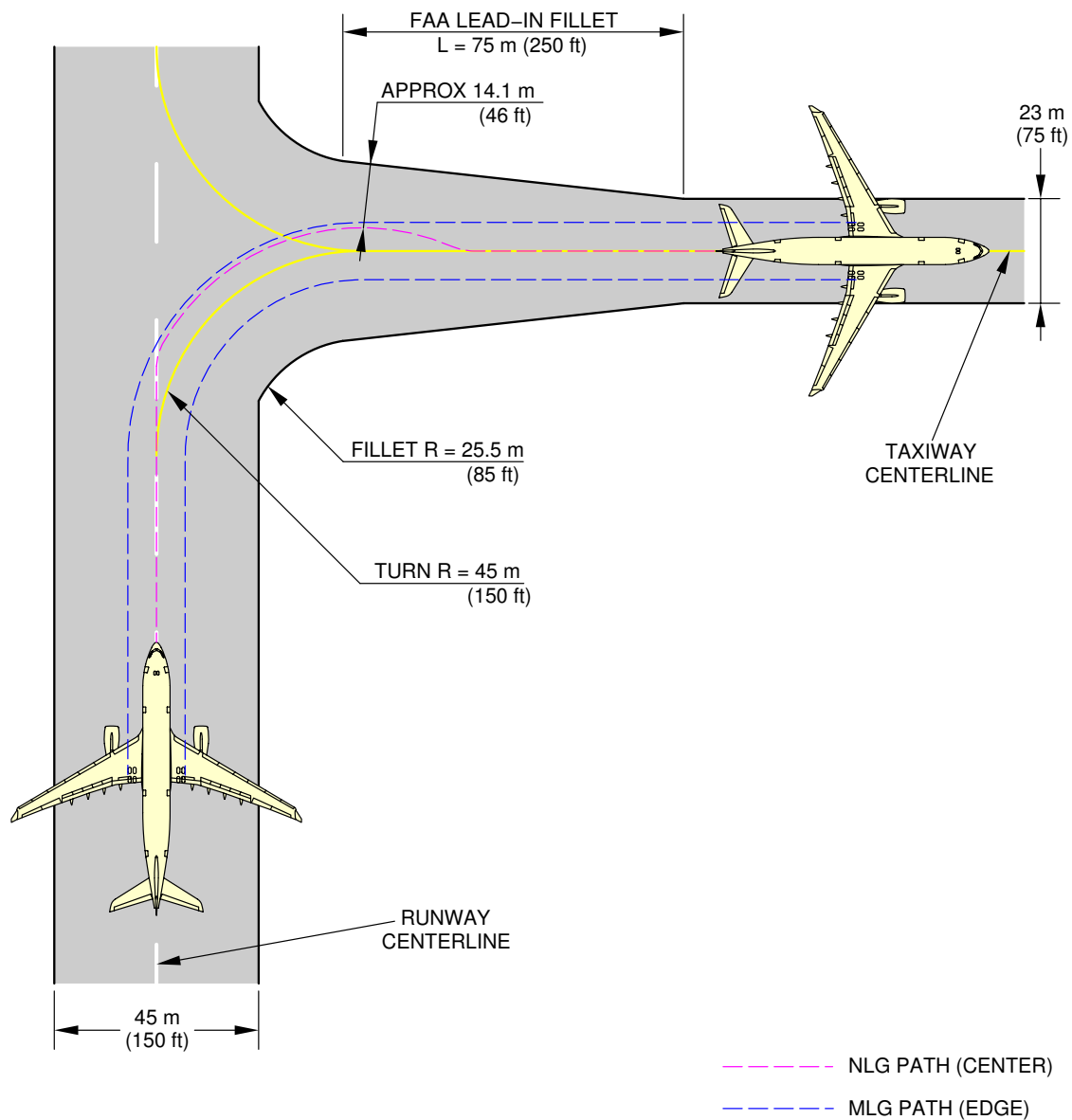

NOTE:
 THE MLG FOLLOWS THE CENTERLINE.
 THE NLG EDGE MARGIN DECREASES BY 0.5 m (2 ft).

F_AC_040502_1_0020101_01_02

90° Turn - Runway to Taxiway
 Judgemental Oversteering Method
 FIGURE-4-5-2-991-002-A01

**ON A/C A330-200 A330-200F A330-800

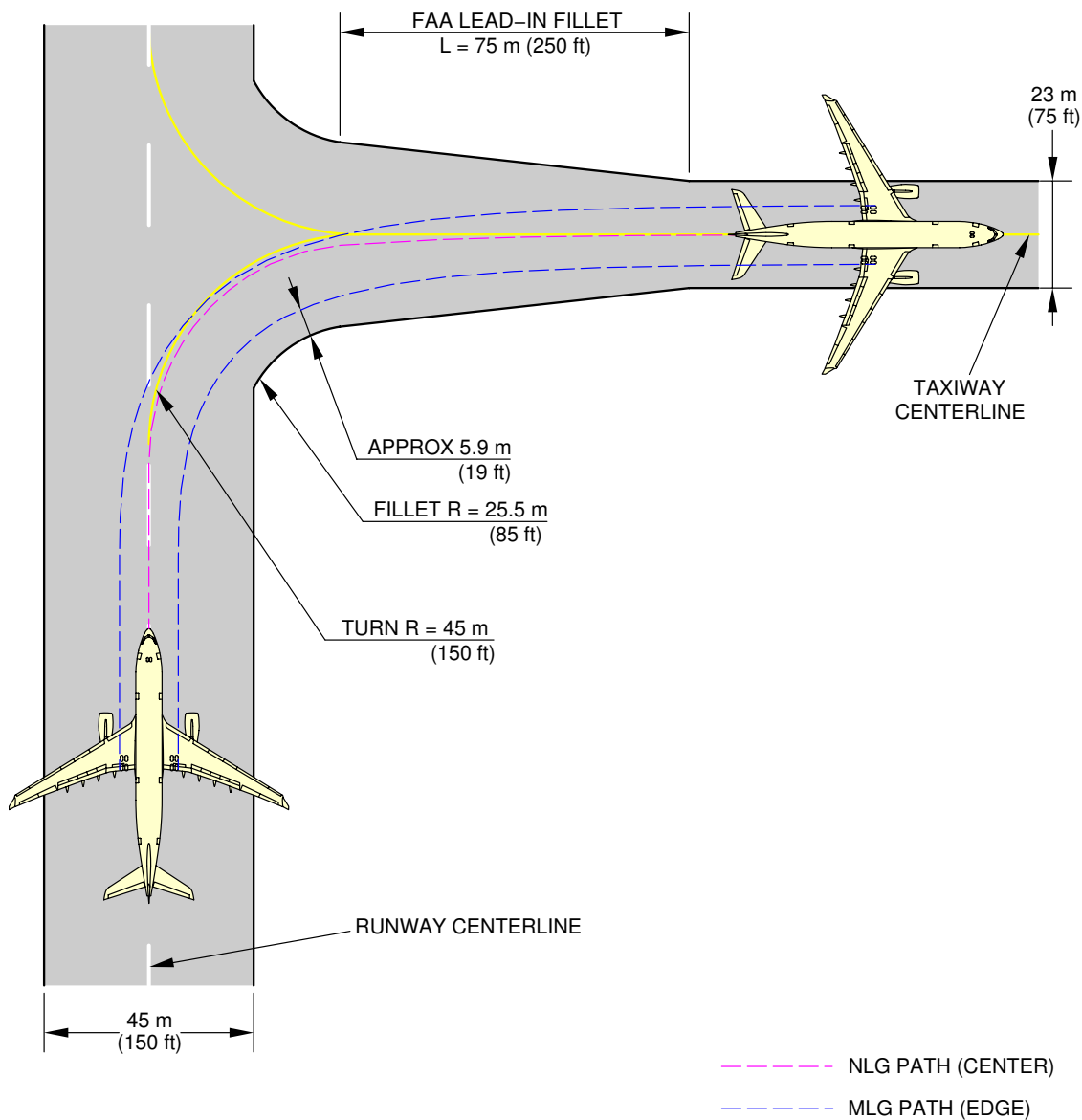

F_AC_040502_1_0090101_01_01

90° Turn - Runway to Taxiway
Cockpit Over Centerline Method
FIGURE-4-5-2-991-009-A01

4-5-3 180° Turn on a Runway

****ON A/C A330-200 A330-200F A330-300 A330-800 A330-900**180° Turn on a Runway

1. This section gives the 180° turn on a runway.

NOTE : The turns in this section show turns on a runway after landing and are not aimed to result in good alignment.

****ON A/C A330-300**

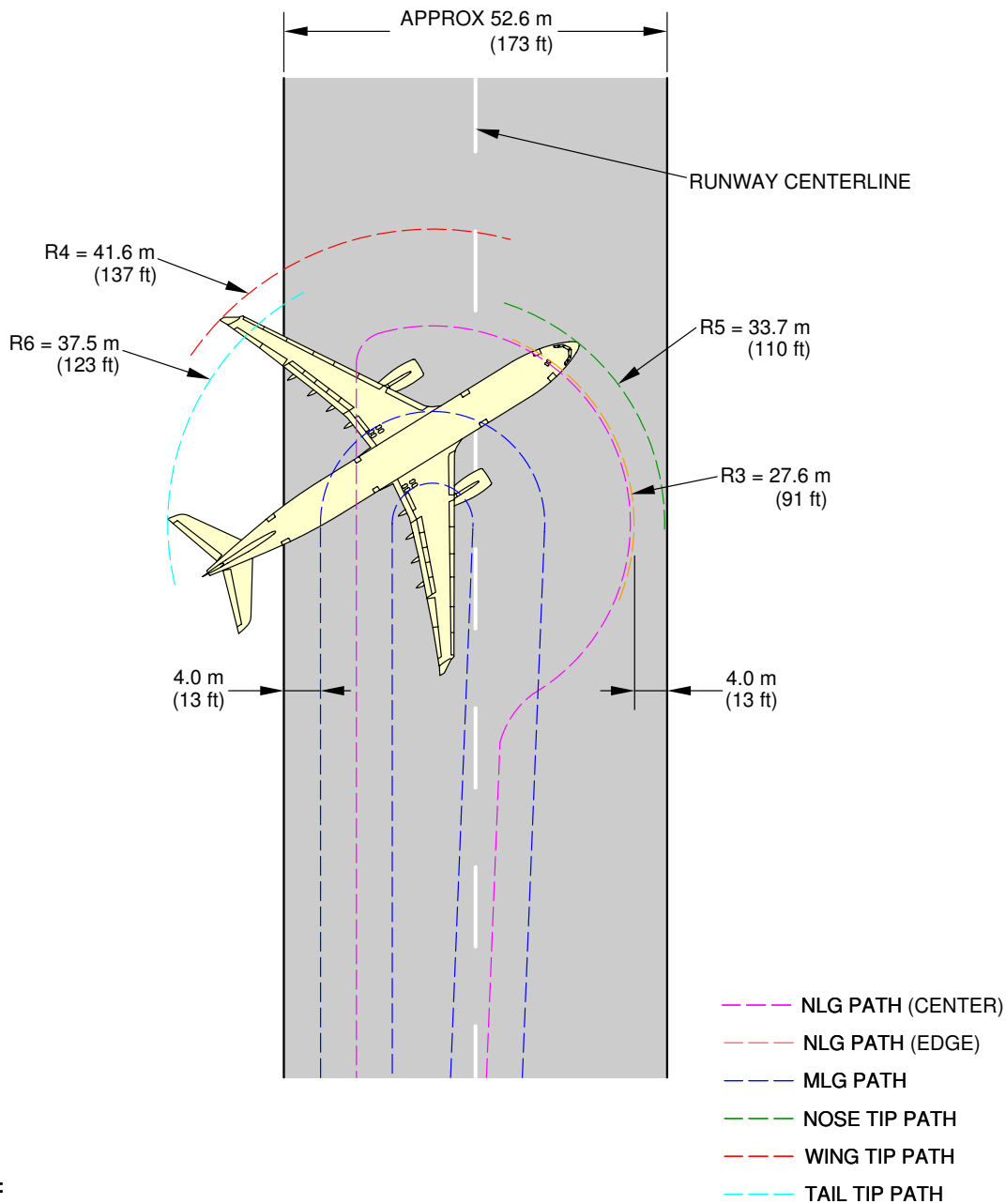

NOTE:

TYPE 1 VALUES FOR MAX STEERING ANGLE = 72°.
IT IS POSSIBLE TO GET LOWER VALUES THAN THOSE FROM TYPE 1
BY APPLYING DIFFERENTIAL BRAKING DURING THE WHOLE TURN.

F_AC_040503_1_0130101_01_04

180° Turn on a Runway
FIGURE-4-5-3-991-013-A01

**ON A/C A330-200 A330-200F

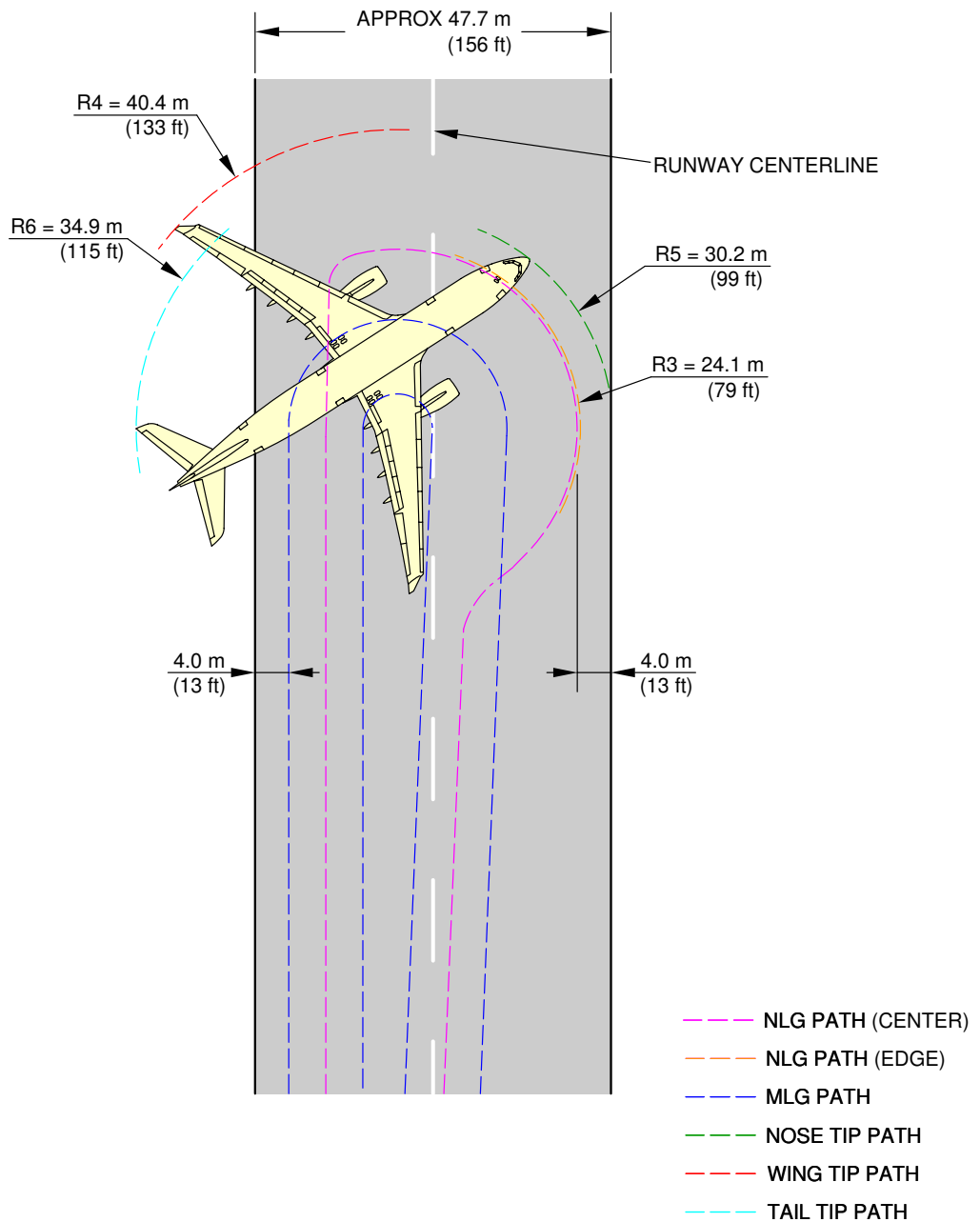

NOTE:

TYPE 1 VALUES FOR MAX STEERING ANGLE = 72°.
IT IS POSSIBLE TO GET LOWER VALUES THAN THOSE FROM TYPE 1
BY APPLYING DIFFERENTIAL BRAKING DURING THE WHOLE TURN.

F_AC_040503_1_0140101_01_03

180° Turn on a Runway
FIGURE-4-5-3-991-014-A01

****ON A/C A330-900**

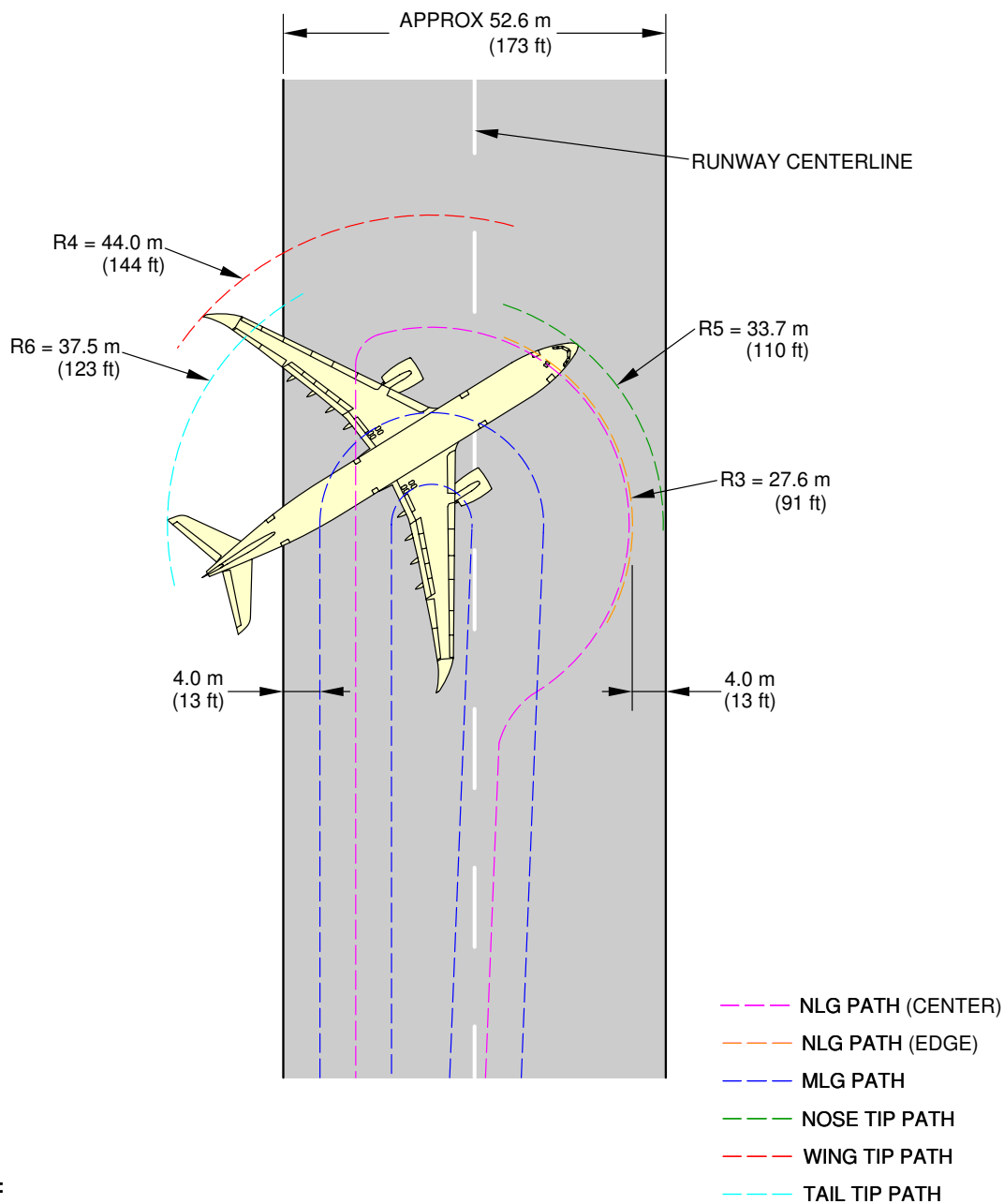

NOTE:

TYPE 1 VALUES FOR MAX STEERING ANGLE = 72°.
IT IS POSSIBLE TO GET LOWER VALUES THAN THOSE FROM TYPE 1
BY APPLYING DIFFERENTIAL BRAKING DURING THE WHOLE TURN.

F_AC_040503_1_0150101_01_01

180° Turn on a Runway
FIGURE-4-5-3-991-015-A01

****ON A/C A330-800**

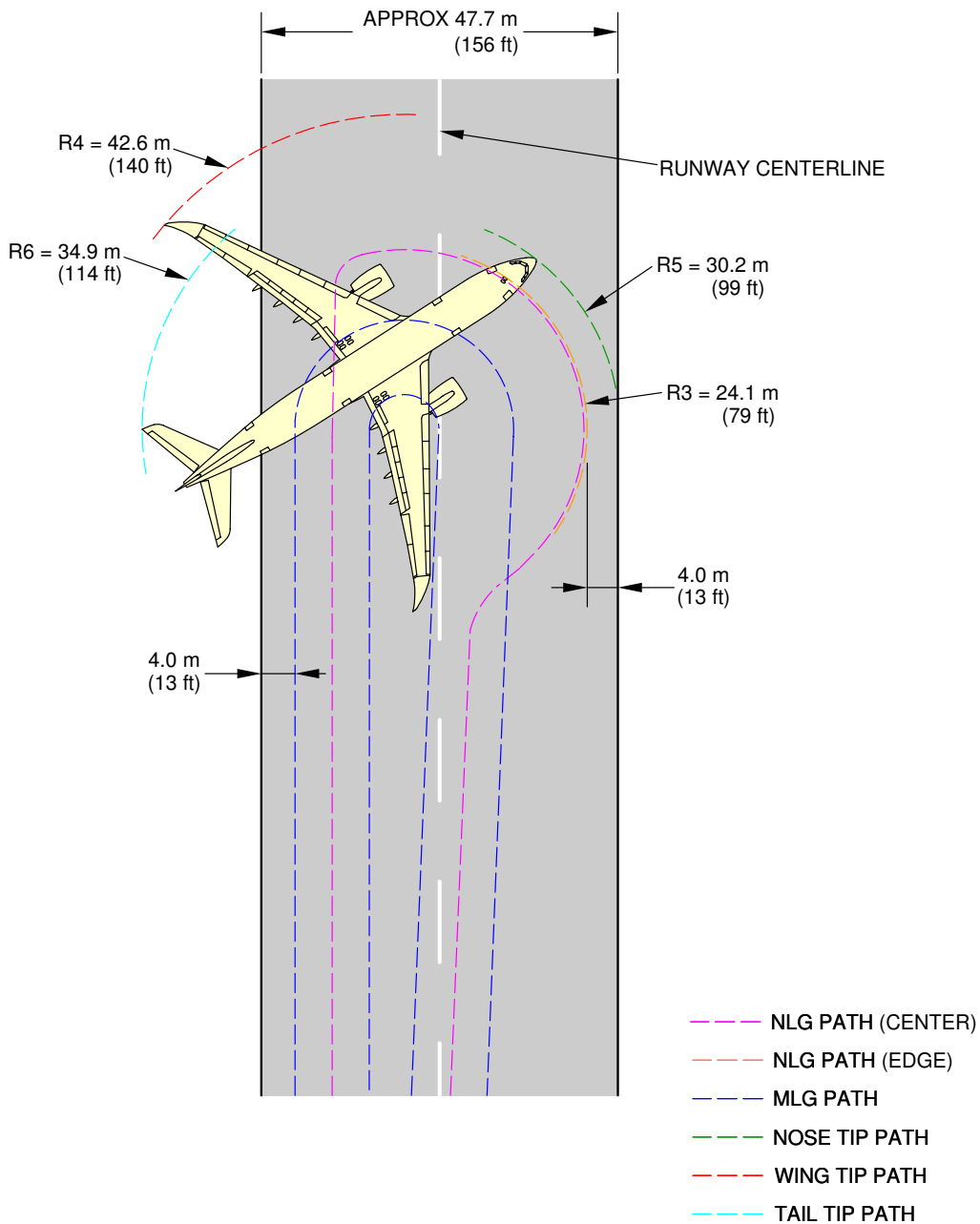

NOTE:

TYPE 1 VALUES FOR MAX STEERING ANGLE = 72°.
IT IS POSSIBLE TO GET LOWER VALUES THAN THOSE FROM TYPE 1
BY APPLYING DIFFERENTIAL BRAKING DURING THE WHOLE TURN.

F_AC_040503_1_0160101_01_01

180° Turn on a Runway
FIGURE-4-5-3-991-016-A01



4-5-4 135° Turn - Taxiway to Taxiway

****ON A/C A330-200 A330-200F A330-300 A330-800 A330-900**

135° Turn - Taxiway to Taxiway

1. This section gives the 135° turn - taxiway to taxiway.

**ON A/C A330-300 A330-900

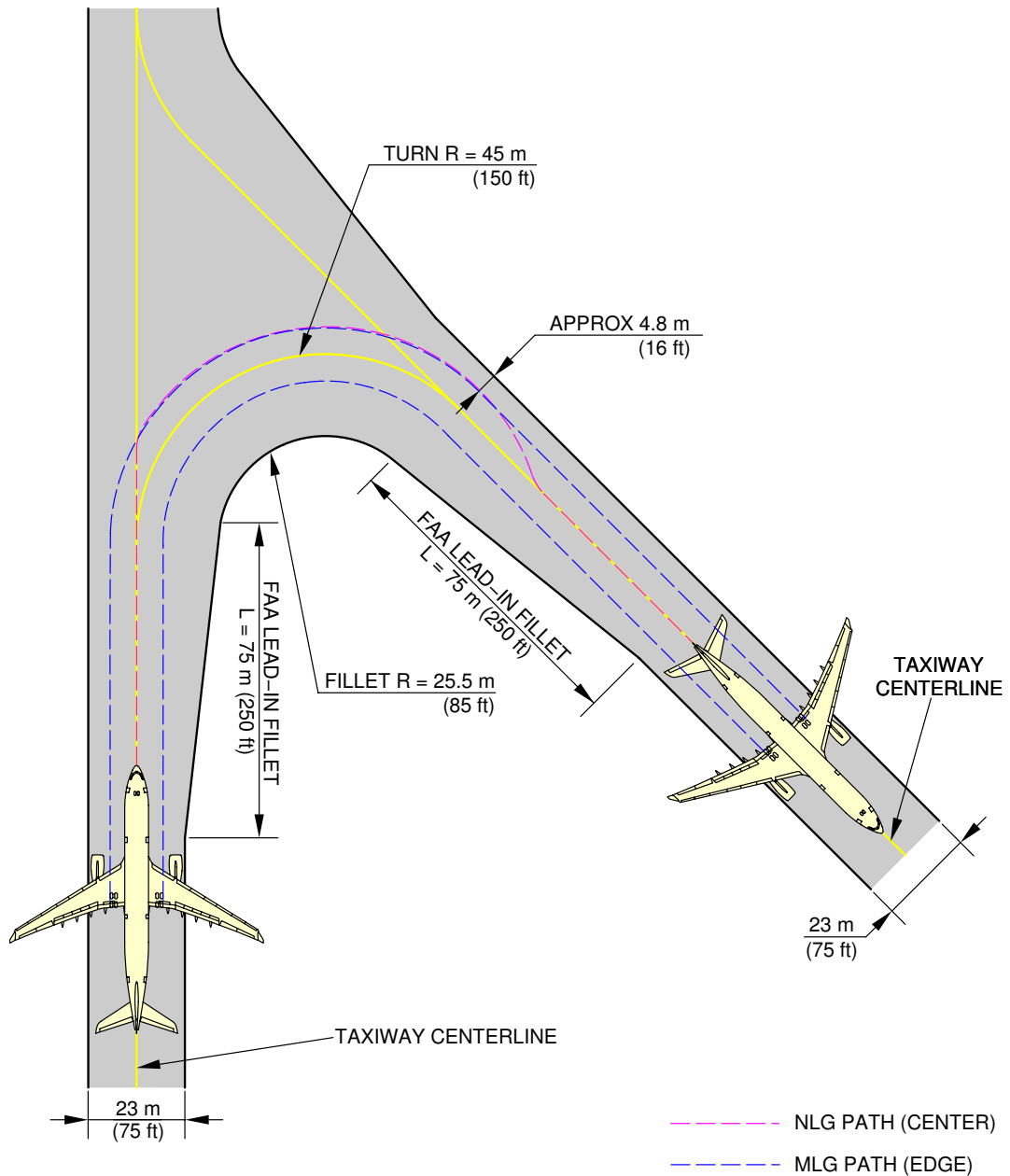

NOTE:
 THE MLG FOLLOWS THE CENTERLINE.
 THE NLG EDGE MARGIN DECREASES BY 0.5 m (2 ft).

F_AC_040504_1_0030101_01_02

135° Turn - Taxiway to Taxiway
 Judgemental Oversteering Method
 FIGURE-4-5-4-991-003-A01

**ON A/C A330-300 A330-900

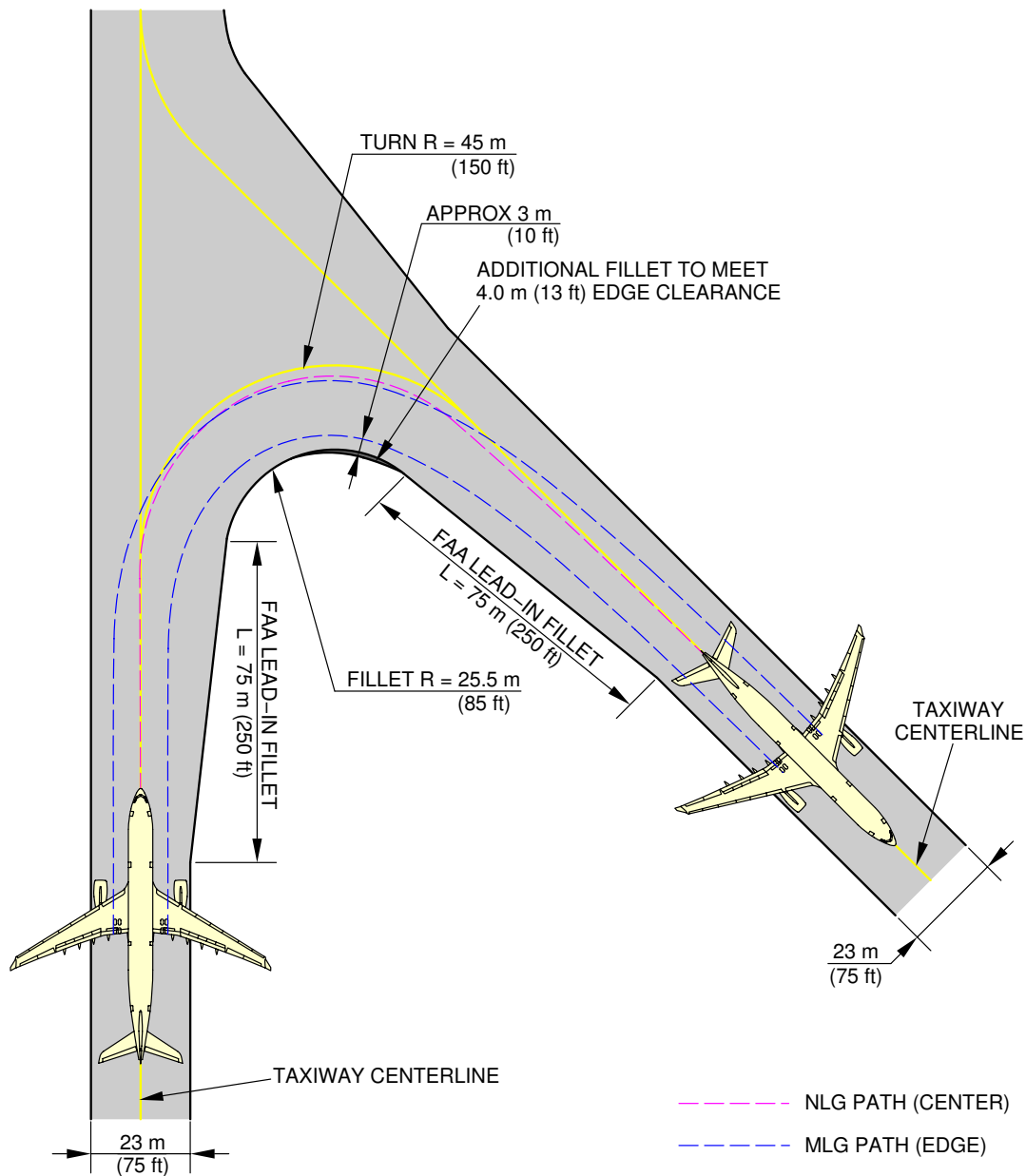

F_AC_040504_1_0070101_01_01

135° Turn - Taxiway to Taxiway
Cockpit Over Centerline Method
FIGURE-4-5-4-991-007-A01

**ON A/C A330-200 A330-200F A330-800

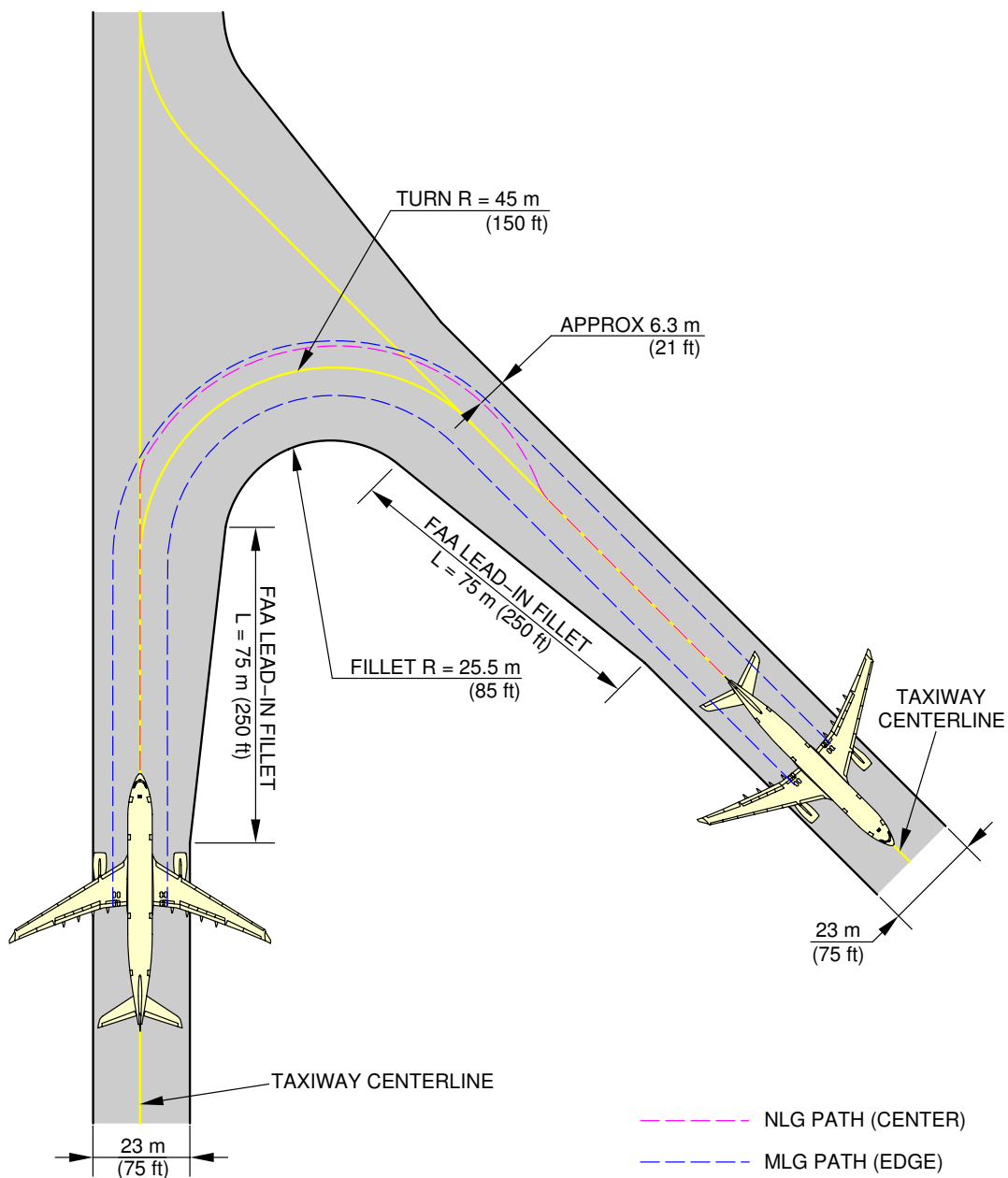

NOTE:
THE MLG FOLLOWS THE CENTERLINE.
THE NLG EDGE MARGIN DECREASES BY 0.5 m (2 ft).

F_AC_040504_1_0040101_01_02

135° Turn - Taxiway to Taxiway
Judgemental Oversteering Method
FIGURE-4-5-4-991-004-A01

**ON A/C A330-200 A330-200F A330-800

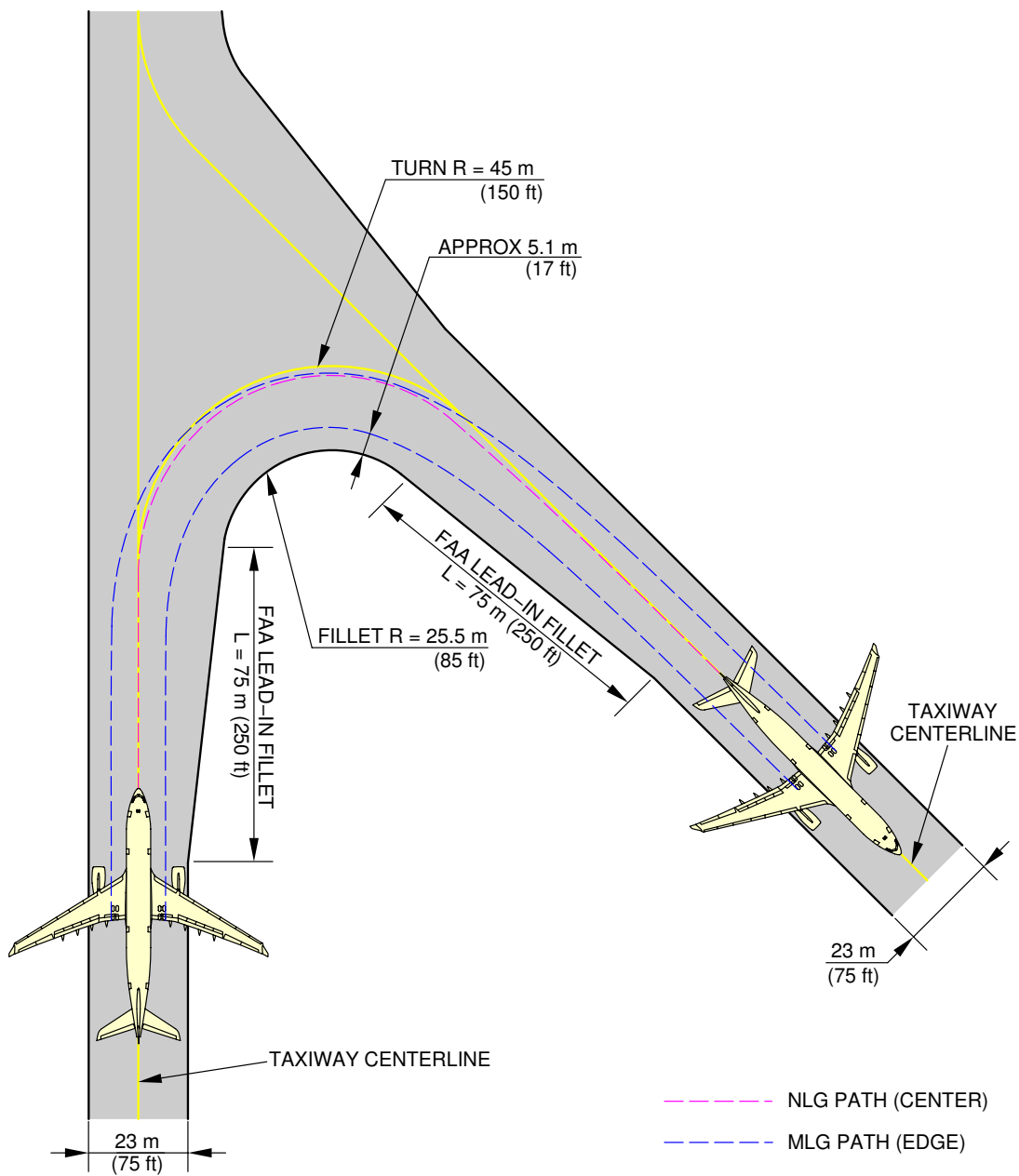

F_AC_040504_1_0080101_01_01

135° Turn - Taxiway to Taxiway
Cockpit Over Centerline Method
FIGURE-4-5-4-991-008-A01



4-5-5 90° Turn - Taxiway to Taxiway

**ON A/C A330-200 A330-200F A330-300 A330-800 A330-900

90° Turn - Taxiway to Taxiway

1. This section gives the 90° turn - taxiway to taxiway.

**ON A/C A330-300 A330-900

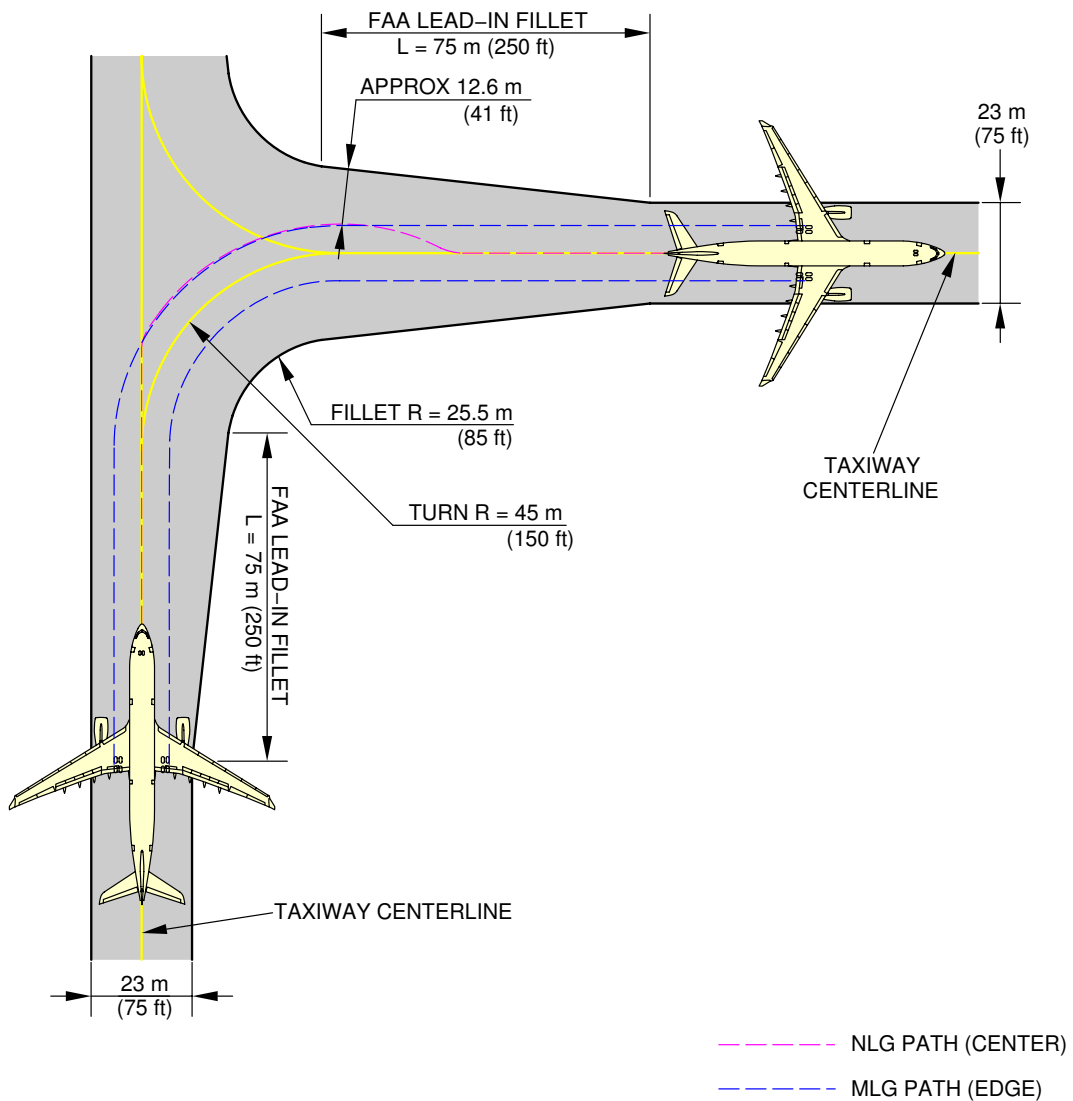

NOTE:
THE MLG FOLLOWS THE CENTERLINE.
THE NLG EDGE MARGIN DECREASES BY 0.5 m (2 ft).

F_AC_040505_1_0030101_01_02

90° Turn - Taxiway to Taxiway
Judgemental Oversteering Method
FIGURE-4-5-5-991-003-A01

**ON A/C A330-300 A330-900

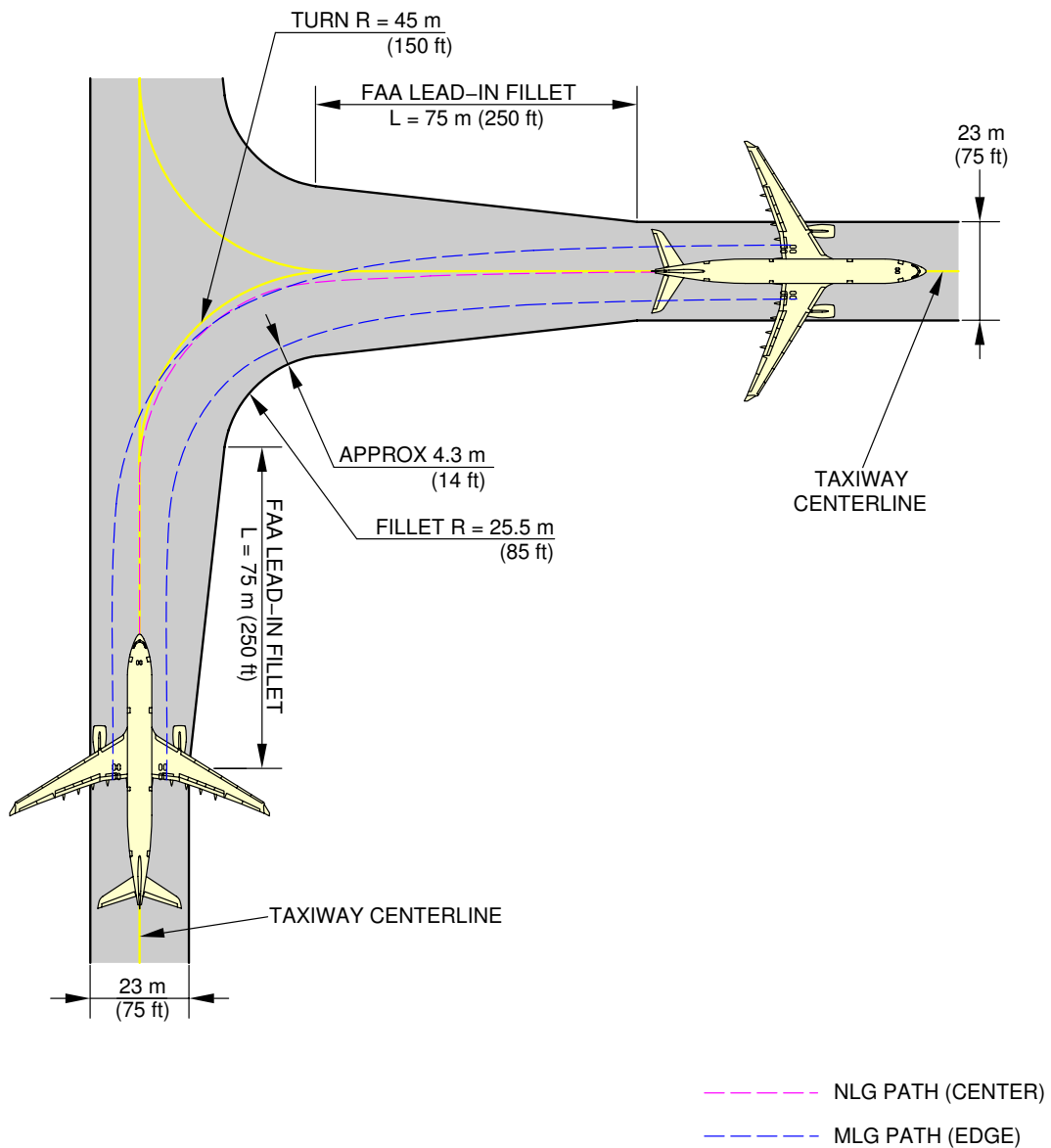

F_AC_040505_1_0100101_01_01

90° Turn - Taxiway to Taxiway
Cockpit Over Centerline Method
FIGURE-4-5-5-991-010-A01

**ON A/C A330-200 A330-200F A330-800

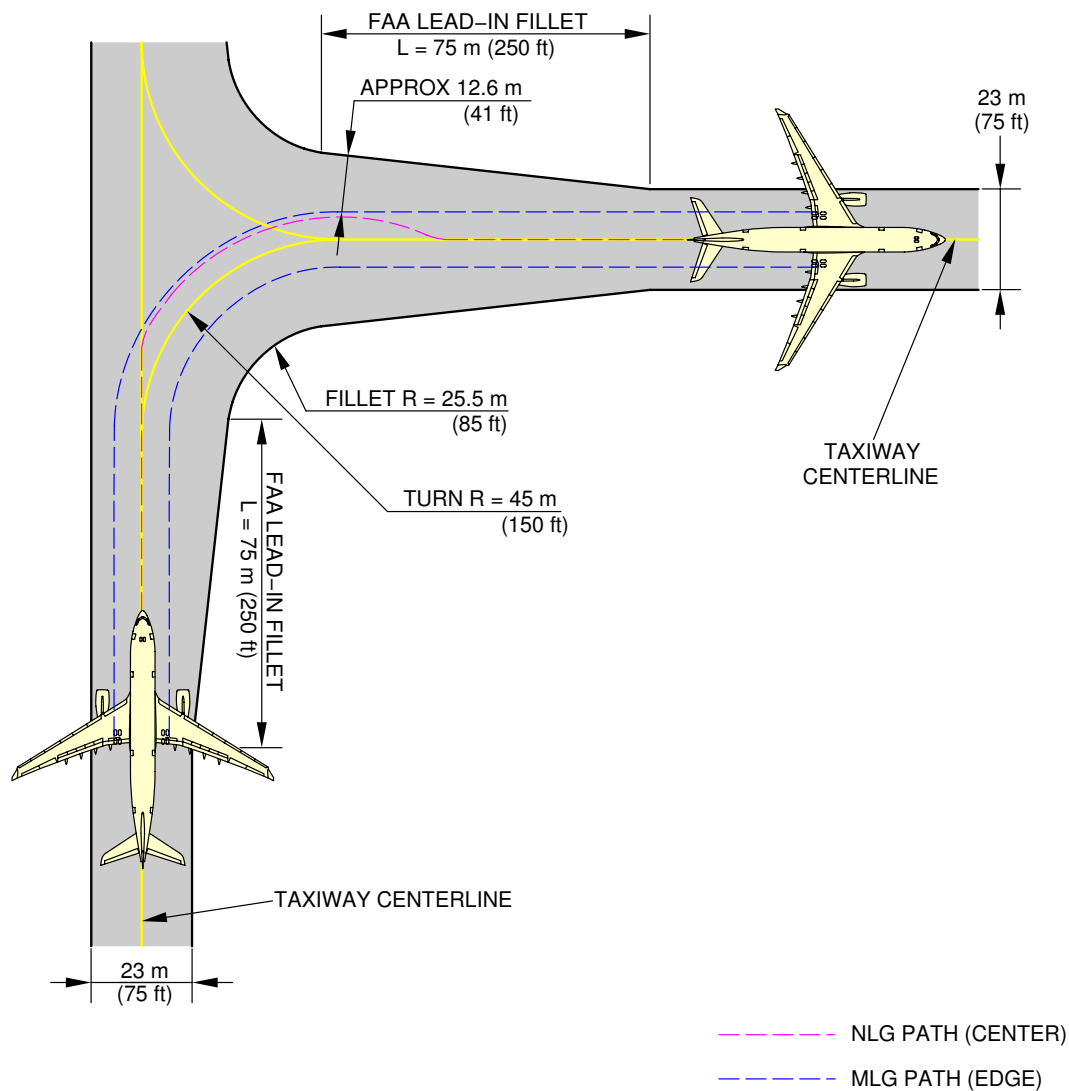

NOTE:
THE MLG FOLLOWS THE CENTERLINE.
THE NLG EDGE MARGIN DECREASES BY 0.5 m (2 ft).

F_AC_040505_1_0040101_01_02

90° Turn - Taxiway to Taxiway
Judgemental Oversteering Method
FIGURE-4-5-5-991-004-A01

**ON A/C A330-200 A330-200F A330-800

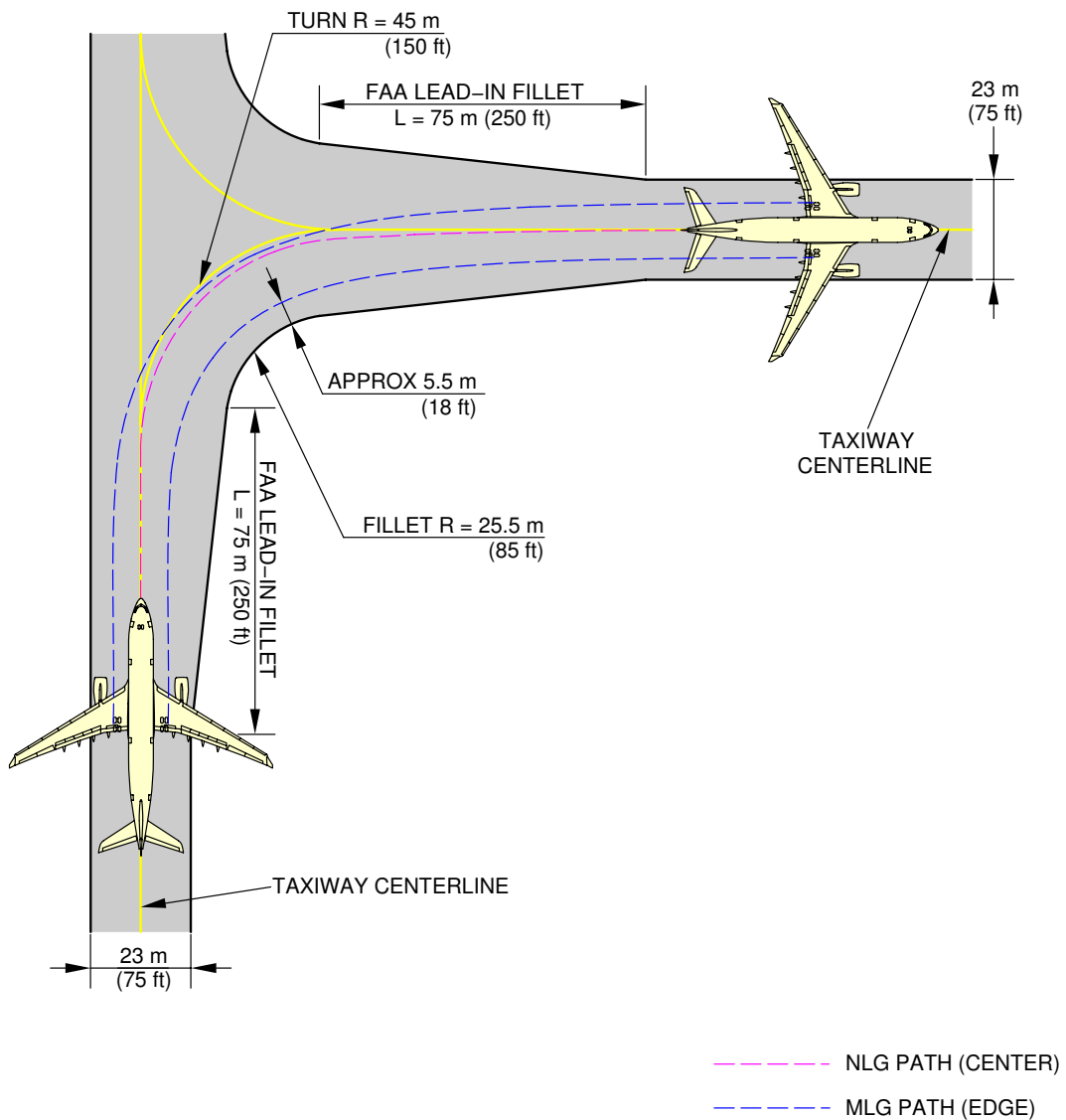

F_AC_040505_1_0110101_01_01

90° Turn - Taxiway to Taxiway
Cockpit Over Centerline Method
FIGURE-4-5-5-991-011-A01



4-6-0 Runway Holding Bay (Apron)

****ON A/C A330-200 A330-200F A330-300 A330-800 A330-900**

Runway Holding Bay (Apron)

1. This section provides the runway holding bay (Apron).

****ON A/C A330-200 A330-200F A330-300**

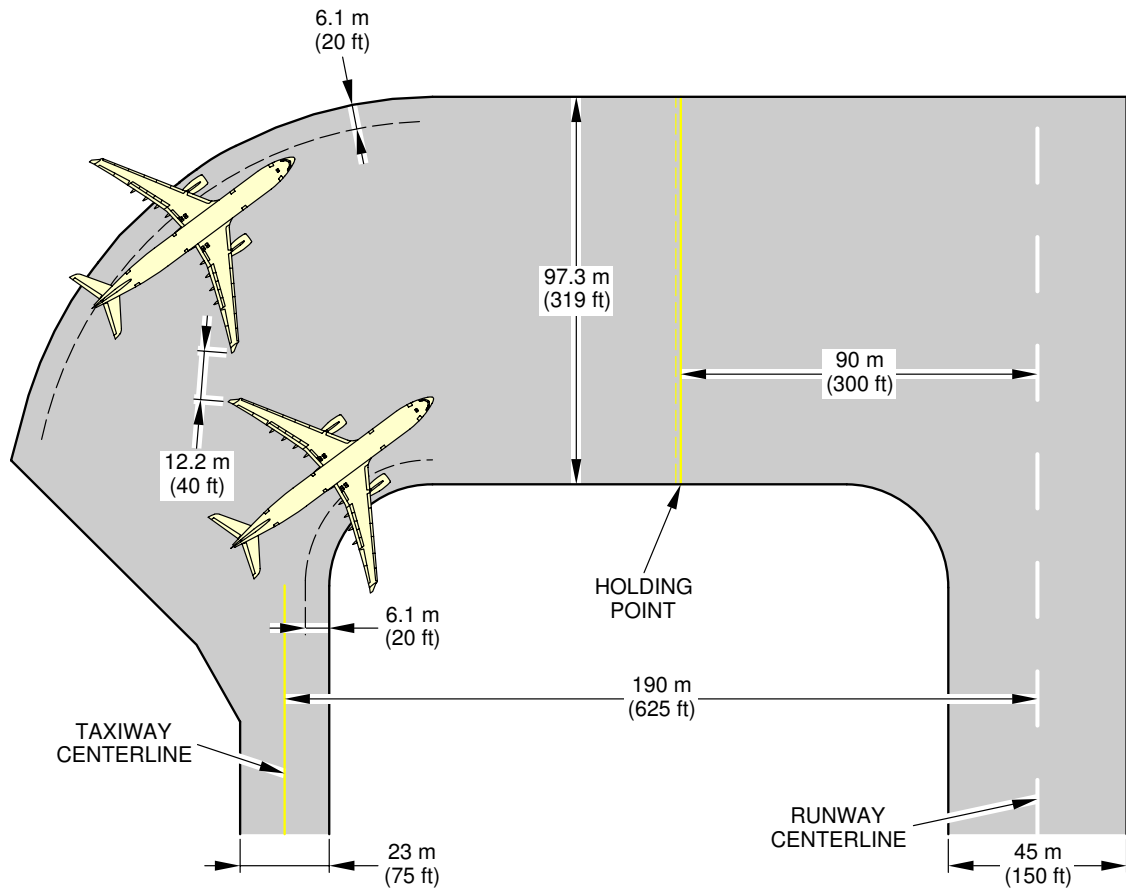

NOTE:
COORDINATE WITH USING AIRLINE FOR SPECIFIC PLANNED OPERATING PROCEDURES.

F_AC_040600_1_0010101_01_02

Runway Holding Bay (Apron)
FIGURE-4-6-0-991-001-A01

**ON A/C A330-800 A330-900

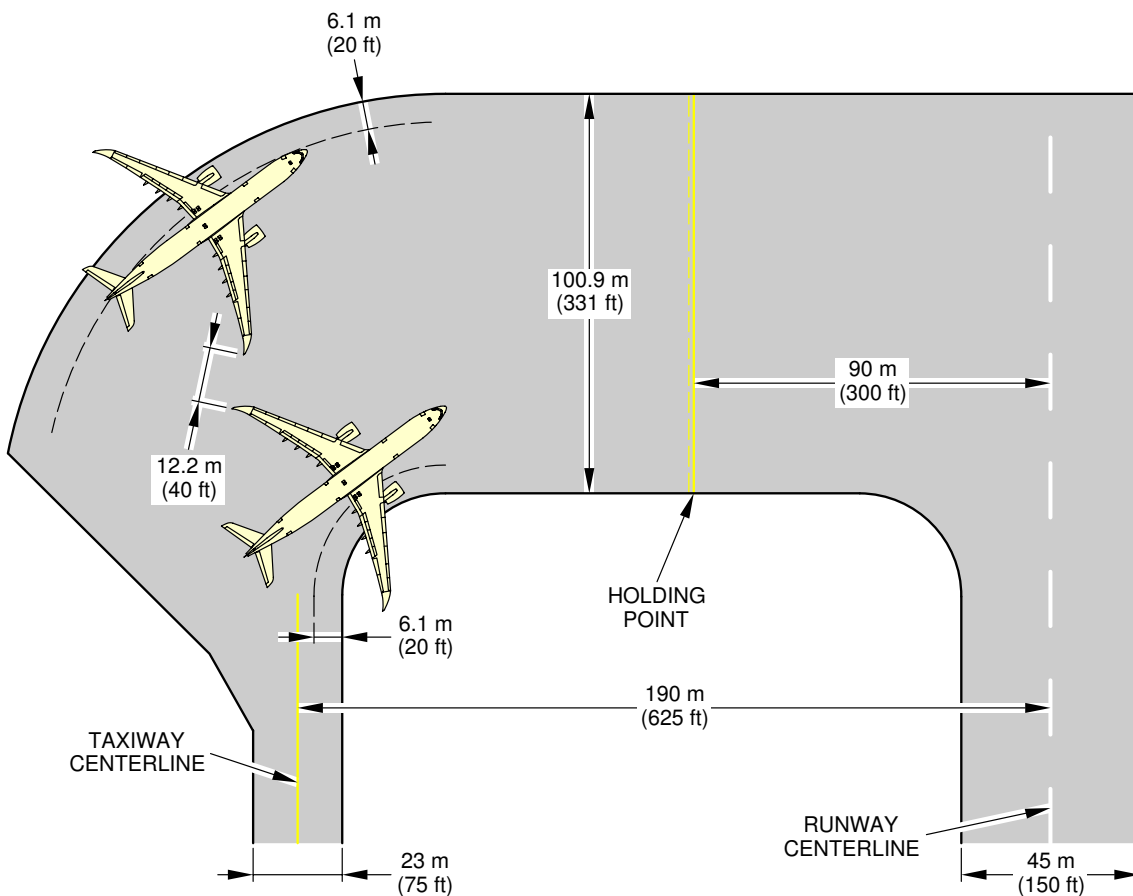

NOTE:

COORDINATE WITH USING AIRLINE FOR SPECIFIC PLANNED OPERATING PROCEDURES.

F_AC_040600_1_0060101_01_00

Runway Holding Bay (Apron)
FIGURE-4-6-0-991-006-A01

4-7-0 Minimum Line-Up Distance Corrections

****ON A/C A330-200 A330-200F A330-300 A330-800 A330-900**

Minimum Line-Up Distance Corrections

1. The ground maneuvers were performed using asymmetric thrust and differential-only braking to initiate the turn.

Maneuvers of this section are calculated with turn characteristics as given in chapter 04-02-00.

TODA: Take-Off Distance Available

ASDA: Acceleration-Stop Distance Available

2. 90° Turn on Runway Entry

This section gives the minimum line-up distance correction for a 90° turn on runway entry.

This maneuver consists in a 90° turn at minimum turn radius. It starts with the edge of the MLG at a distance of 4.0 m (13 ft) from the taxiway edge, and finishes with the aircraft aligned on the centerline of the runway, see FIGURE 4-7-0-991-019-A.

During the turn, all the clearances must meet the minimum value of 4.0 m (13 ft) for this category of aircraft as recommended in ICAO Annex 14 (Eighth Edition).

3. 180° Turn on Runway Turn Pad

This section gives the minimum line-up distance correction for a 180° turn on the runway turn pad. This maneuver consists in a 180° turn at minimum turn radius on a runway turn pad with standard ICAO geometry.

It starts with the edge of the MLG at a distance of 4.0 m (13 ft) from the pavement edge, and it finishes with the aircraft aligned on the centerline of the runway, see FIGURE 4-7-0-991-020-A.

During the turn, all the clearances must meet the minimum value of 4.0 m (13 ft) for this category of aircraft as recommended in ICAO Annex 14 (Eighth Edition).

4. 180° Turn on Runway Width

This section gives the minimum line-up distance correction for a 180° turn on the runway width. For this maneuver, the pavement width is considered to be the runway width, which is a frozen parameter (45 m (150 ft) and 60 m (200 ft)).

As per the standard operating procedures for the "180° turn on runway" (described in the Flight Crew Operating Manual (FCOM)), the aircraft is initially angled with respect to the runway centerline when starting the 180° turn, see FIGURE 4-7-0-991-021-A.

The value of this angle depends on the aircraft type and is mentioned in the FCOM.

During the turn, all the clearances must meet the minimum value of 4.0 m (13 ft) for this category of aircraft as recommended in ICAO Annex 14 (Eighth Edition).

NOTE : The minimum line-up distances may need a lower steering angle than maximum steering angle.

**ON A/C A330-200 A330-200F A330-300 A330-800 A330-900

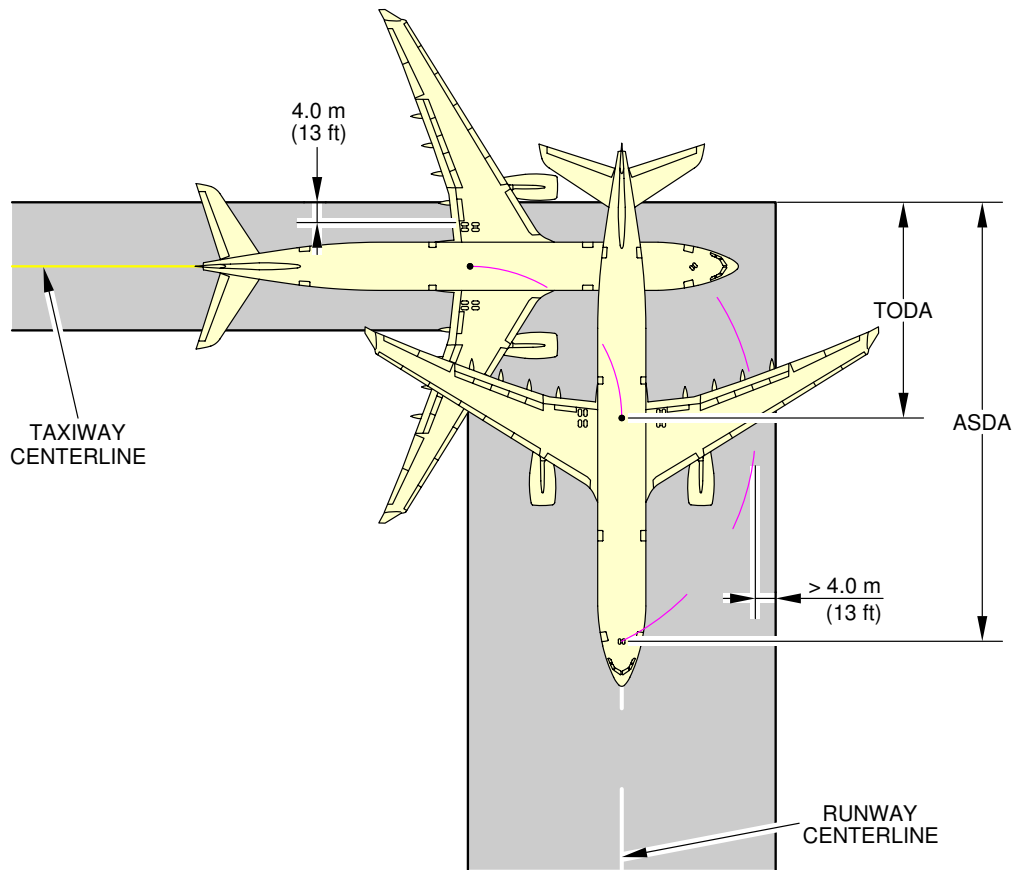

90° TURN ON RUNWAY ENTRY					
AIRCRAFT TYPE	MAX STEERING ANGLE	45 m (150 ft)/60 m (200 ft) WIDE RUNWAY			
		MINIMUM LINE-UP DISTANCE CORRECTION			
		ON TODA		ON ASDA	
A330-200/-200F	65°	22.0 m	72 ft	44.5 m	146 ft
A330-200/-200F/-800	72°	19.2 m	63 ft	41.4 m	136 ft
A330-300	65°	23.7 m	78 ft	49.1 m	161 ft
A330-300/-900	72°	20.7 m	68 ft	46.0 m	151 ft

NOTE:

ASDA: ACCELERATION-STOP DISTANCE AVAILABLE

TODA: TAKE-OFF DISTANCE AVAILABLE

F_AC_040700_1_0190101_01_02

Minimum Line-Up Distance Corrections
90° Turn on Runway Entry
FIGURE-4-7-0-991-019-A01

****ON A/C A330-200 A330-200F A330-300 A330-800 A330-900**

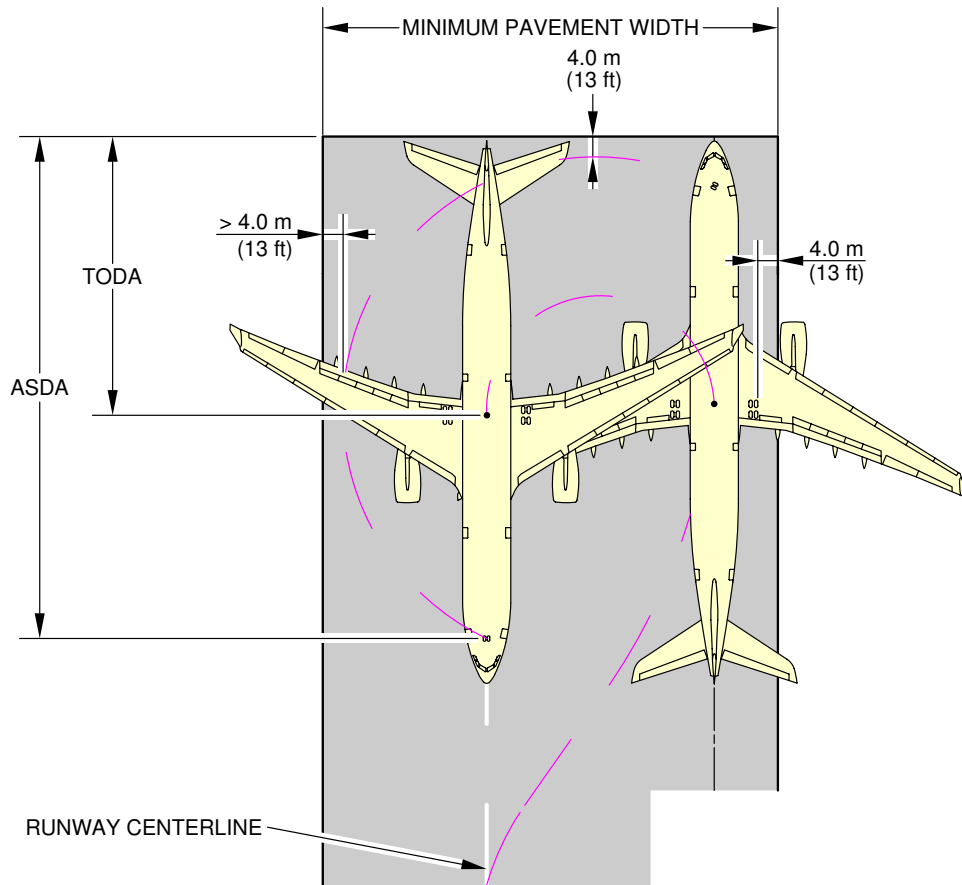

180° TURN ON RUNWAY TURNPAD							
AIRCRAFT TYPE	MAX STEERING ANGLE	45 m (150 ft)/60 m (200 ft) WIDE RUNWAY				REQUIRED MINIMUM PAVEMENT WIDTH	
		MINIMUM LINE-UP DISTANCE CORRECTION					
		ON TODA		ON ASDA			
A330-200/-200F	65°	29.6 m	97 ft	51.2 m	168 ft	56.2 m	184 ft
A330-200/-200F/-800	72°	28.4 m	93 ft	50.6 m	166 ft	50.6 m	166 ft
A330-300	65°	33.2 m	109 ft	58.6 m	192 ft	59.7 m	196 ft
A330-300/-900	72°	31.9 m	105 ft	57.3 m	188 ft	53.5 m	176 ft

NOTE:

ASDA: ACCELERATION-STOP DISTANCE AVAILABLE

TODA: TAKE-OFF DISTANCE AVAILABLE

F_AC_040700_1_0200101_01_02

Minimum Line-Up Distance Corrections
180° Turn on Runway Turn Pad
FIGURE-4-7-0-991-020-A01

****ON A/C A330-200 A330-200F A330-300 A330-800 A330-900**

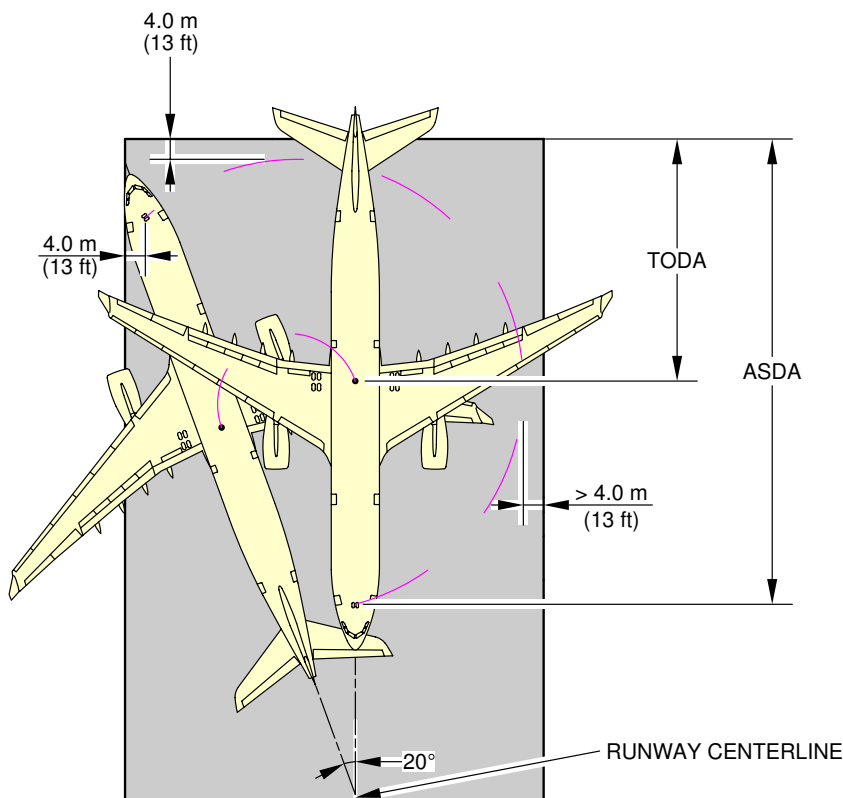

180° TURN ON RUNWAY WIDTH							
AIRCRAFT TYPE	MAX STEERING ANGLE	45 m (150 ft) WIDE RUNWAY (STANDARD WIDTH)		60 m (200 ft) WIDE RUNWAY			
		MINIMUM LINE-UP DISTANCE CORRECTION		MINIMUM LINE-UP DISTANCE CORRECTION			
		ON TODA	ON ASDA	ON TODA	ON ASDA	ON TODA	ON ASDA
A330-200/-200F	65°	NOT POSSIBLE		43.3 m	142 ft	65.5 m	215 ft
A330-200/-200F/-800	72°			28.4 m	93 ft	50.6 m	166 ft
A330-300	65°			53.2 m	175 ft	78.6 m	258 ft
A330-300/-900	72°			42.6 m	140 ft	68.0 m	223 ft

NOTE:

ASDA: ACCELERATION-STOP DISTANCE AVAILABLE

TODA: TAKE-OFF DISTANCE AVAILABLE

F_AC_040700_1_0210101_01_02

Minimum Line-Up Distance Corrections
180° Turn on Runway Width
FIGURE-4-7-0-991-021-A01



4-8-0 Aircraft Mooring

**ON A/C A330-200 A330-200F A330-300 A330-800 A330-900

Aircraft Mooring

1. This section provides information on aircraft mooring.

**ON A/C A330-200 A330-200F A330-300 A330-800 A330-900

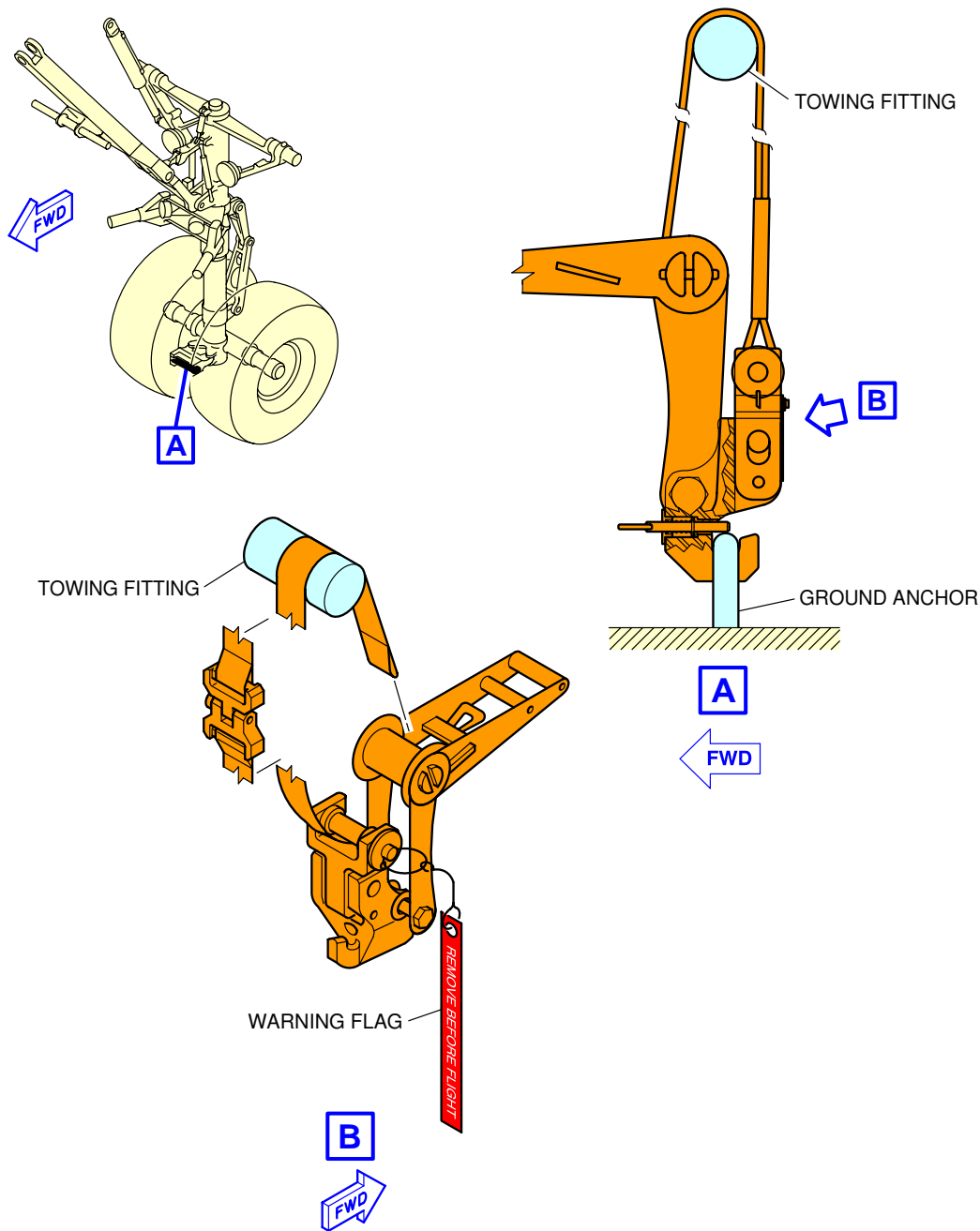

F_AC_040800_1_0010101_01_00

Aircraft Mooring
FIGURE-4-8-0-991-001-A01

TERMINAL SERVICING

5-1-0 Aircraft Servicing Arrangements

****ON A/C A330-200 A330-200F A330-300 A330-800 A330-900**Aircraft Servicing Arrangements

1. This section provides typical ramp layouts, showing the various GSE items in position during typical turn-round scenarios for passenger and cargo aircraft.

These ramp layouts show typical arrangements only. Each operator will have its own specific requirements/regulations for positioning and operation on the ramp.

5-1-1 Symbols Used on Servicing Diagrams

****ON A/C A330-200 A330-200F A330-300 A330-800 A330-900**Symbols Used on Servicing Diagrams

1. This table gives the symbols used on servicing diagrams.

Ground Support Equipment	
AC	AIR CONDITIONING UNIT
AS	AIR START UNIT
BULK	BULK TRAIN
CAT	CATERING TRUCK
CB	CONVEYOR BELT
CLEAN	CLEANING TRUCK
FUEL	FUEL HYDRANT DISPENSER or TANKER
GPU	GROUND POWER UNIT
LD CL	LOWER DECK CARGO LOADER
LV	LAVATORY VEHICLE
MD CL (A330-200F only)	MAIN DECK CARGO LOADER
PBB	PASSENGER BOARDING BRIDGE
PS	PASSENGER STAIRS
TOW	TOW TRACTOR
ULD	ULD TRAIN
WV	POTABLE WATER VEHICLE

5-1-2 Typical Ramp Layout - Open Apron****ON A/C A330-200 A330-300 A330-800 A330-900**Typical Ramp Layout - Open Apron

1. This section provides the typical servicing arrangements on the open apron, for the passenger version of the aircraft.
The Stand Safety Line delimits the Aircraft Safety Area (minimum distance of 7.5 m (24.61 ft) from the aircraft). No vehicle must be parked in this area before complete stop of the aircraft (wheel chocks in position on landing gears).

****ON A/C A330-200 A330-800**

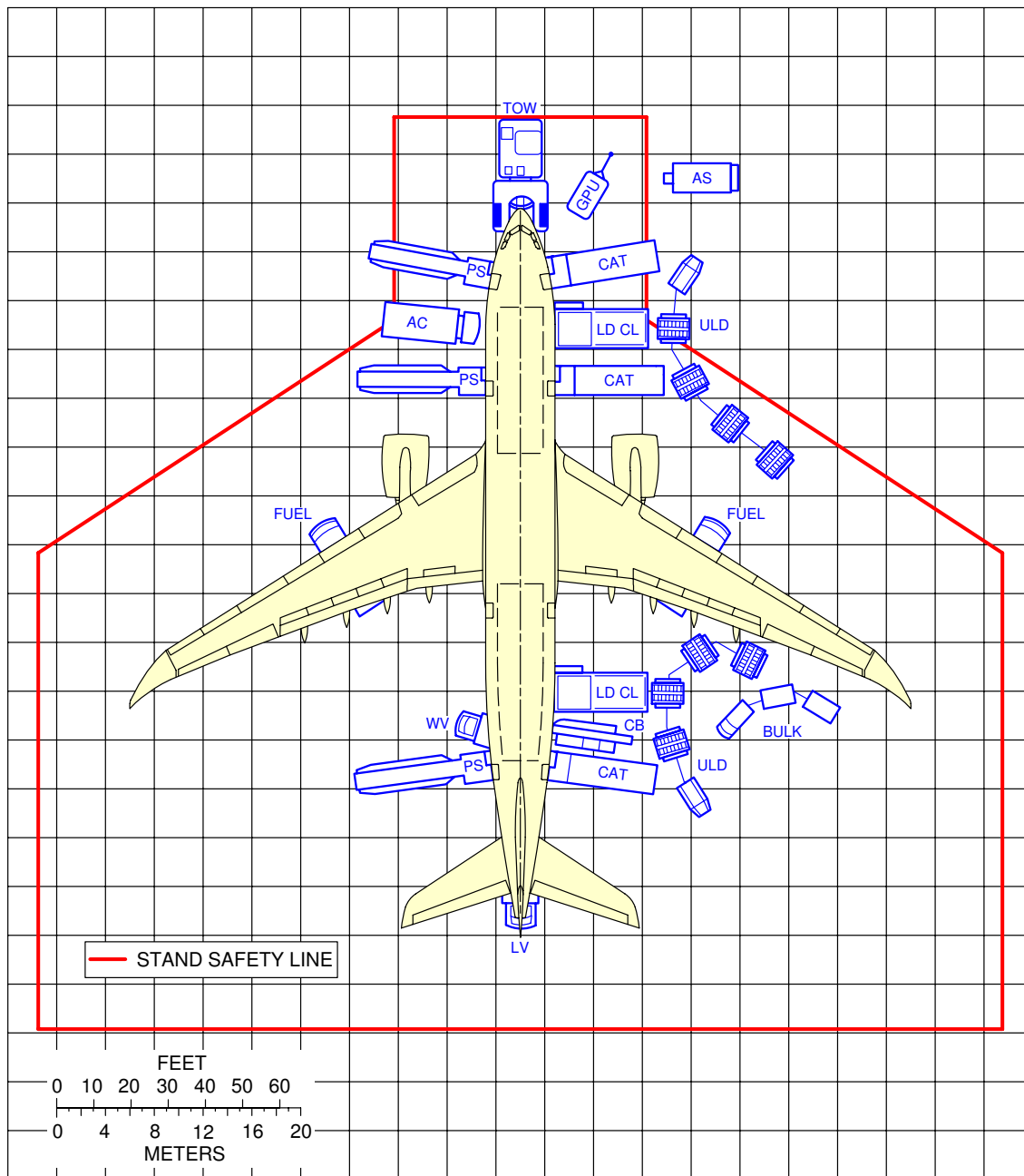

NOTE:
TYPICAL RAMP LAYOUT APPLICABLE TO A330-200 AND A330-800.

F_AC_050102_1_0010101_01_03

Typical Ramp Layout
Open Apron
FIGURE-5-1-2-991-001-A01

****ON A/C A330-300 A330-900**

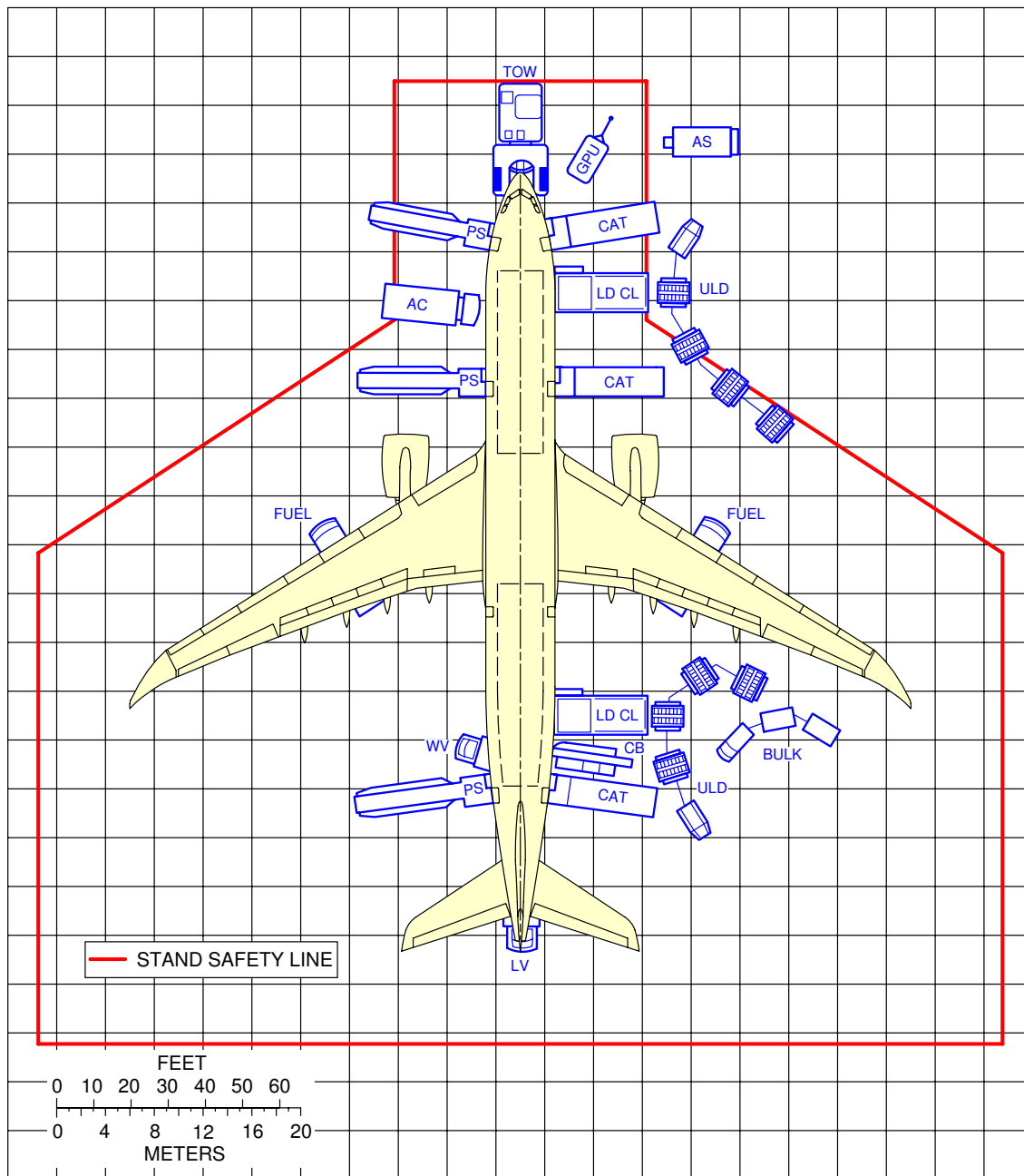

NOTE:
TYPICAL RAMP LAYOUT APPLICABLE TO A330-300 AND A330-900.

F_AC_050102_1_0070101_01_02

Typical Ramp Layout
Open Apron
FIGURE-5-1-2-991-007-A01

****ON A/C A330-200F**Typical Ramp Layout - Open Apron

1. This section provides the typical servicing arrangements on the open apron, for the cargo version of the aircraft.
The Stand Safety Line delimits the Aircraft Safety Area (minimum distance of 7.5 m (24.61 ft) from the aircraft). No vehicle must be parked in this area before complete stop of the aircraft (wheel chocks in position on landing gears).

**ON A/C A330-200F

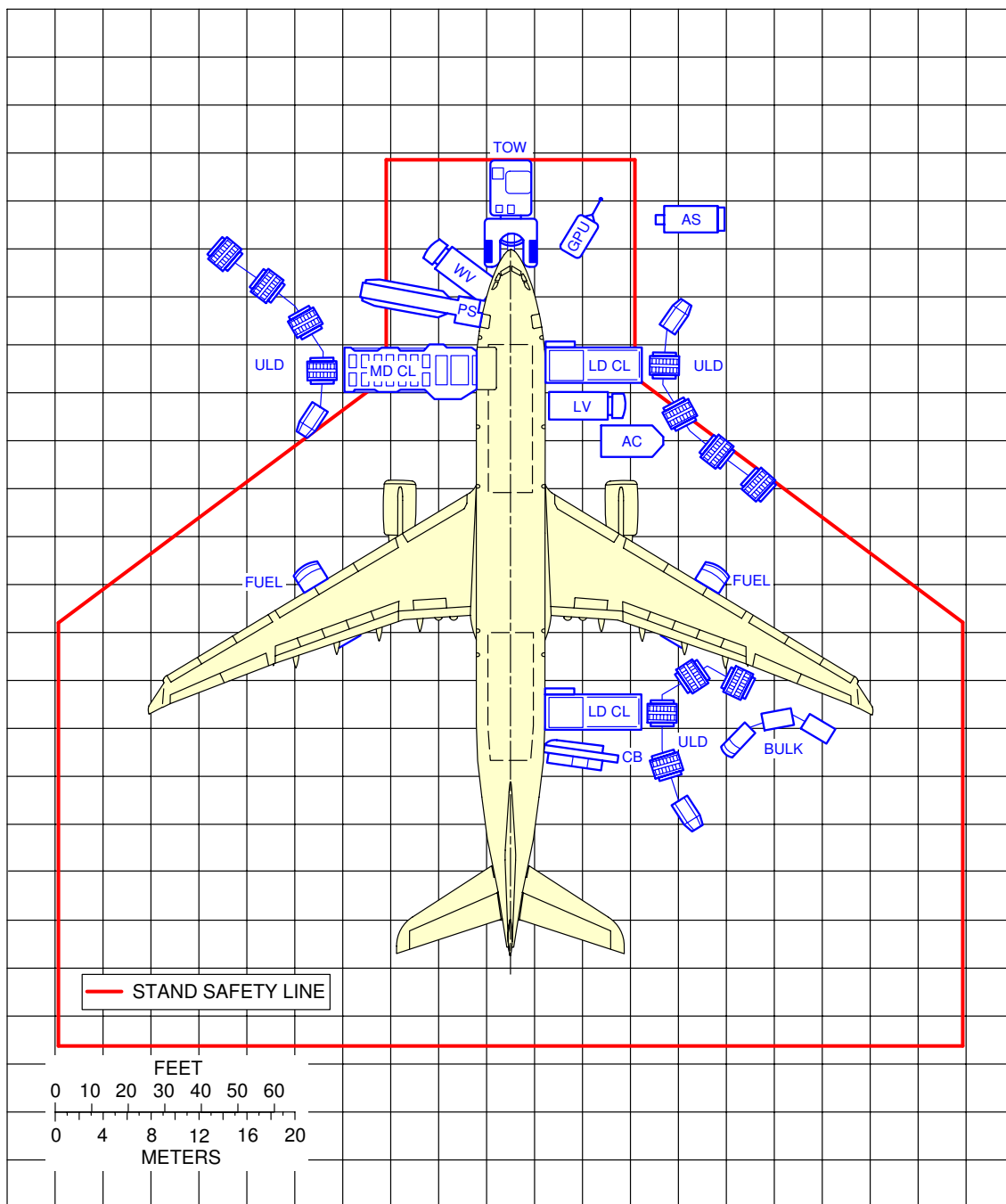

F_AC_050102_1_0020101_01_03

Typical Ramp Layout
Open Apron
FIGURE-5-1-2-991-002-A01

5-1-3 Typical Ramp Layout - Gate****ON A/C A330-200 A330-300 A330-800 A330-900**Typical Ramp Layout - Gate

1. This section provides the typical servicing arrangements in the gate area for the passenger version of the aircraft, with two Passenger Boarding Bridges.
The Stand Safety Line delimits the Aircraft Safety Area (minimum distance of 7.5 m (24.61 ft) from the aircraft). No vehicle must be parked in this area before complete stop of the aircraft (wheel chocks in position on landing gears).

**ON A/C A330-200 A330-800

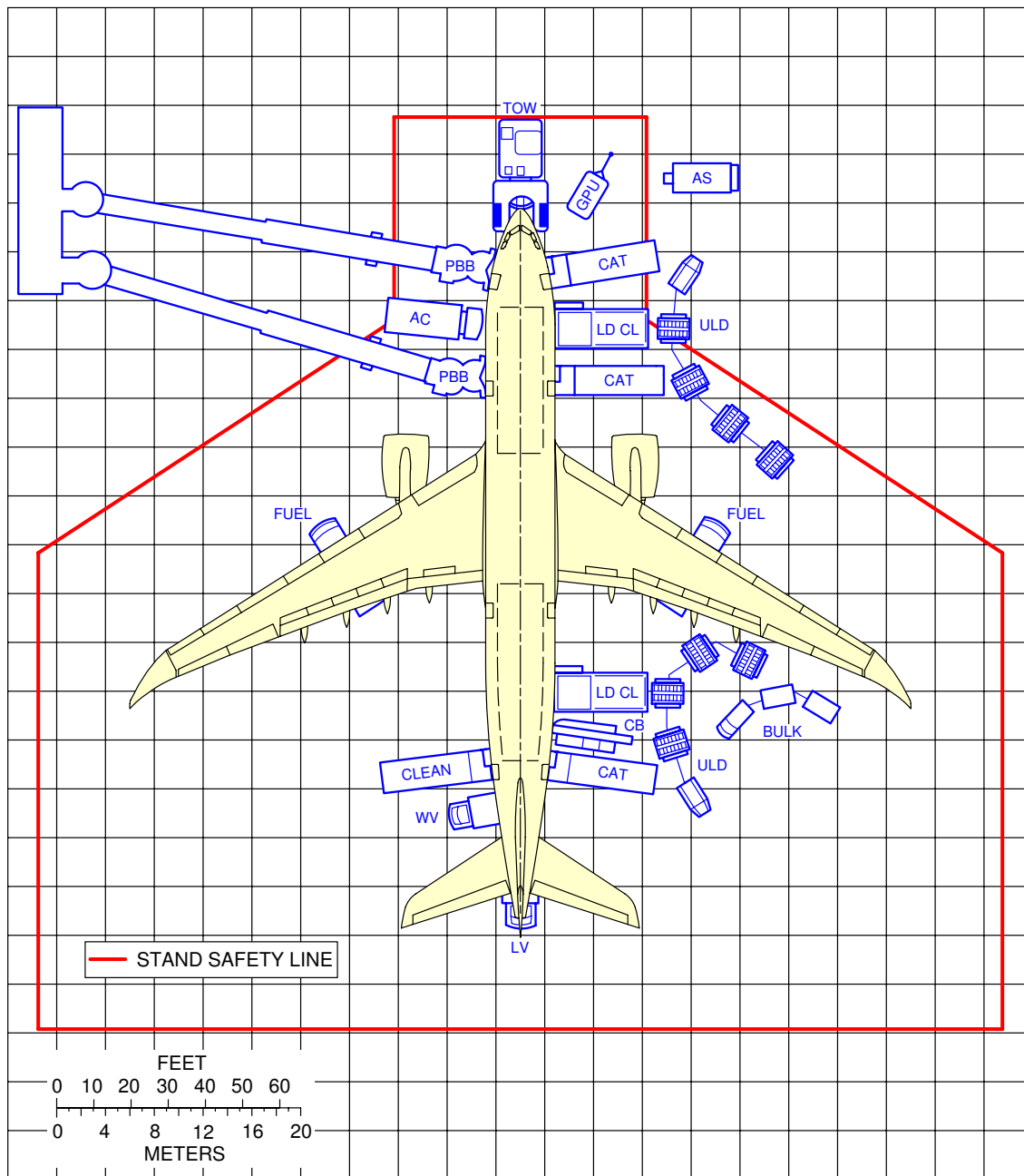

NOTE:
TYPICAL RAMP LAYOUT APPLICABLE TO A330-200 AND A330-800.

F_AC_050103_1_0010101_01_03

Typical Ramp Layout
Gate
FIGURE-5-1-3-991-001-A01

****ON A/C A330-300 A330-900**

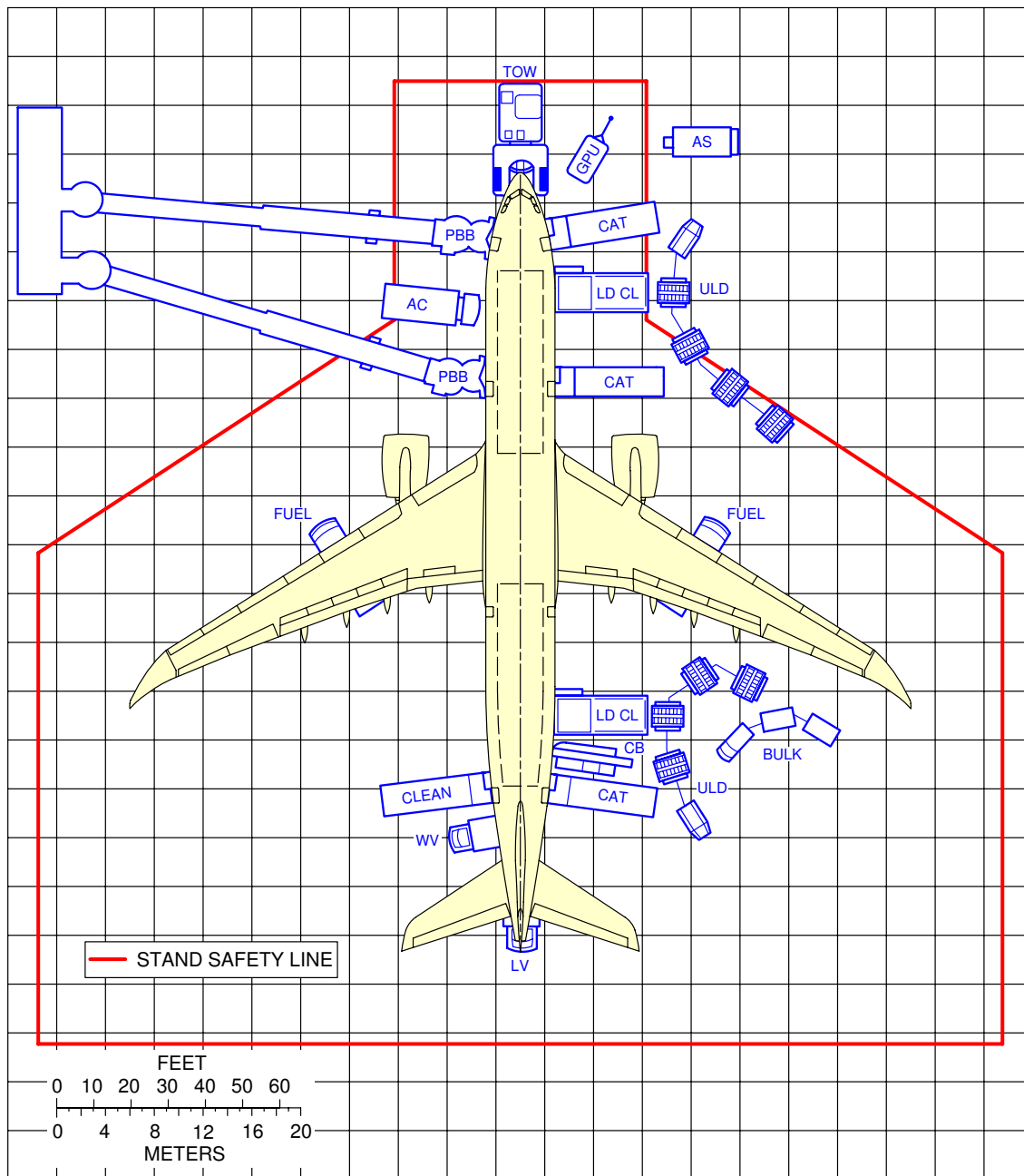

NOTE:
TYPICAL RAMP LAYOUT APPLICABLE TO A330-300 AND A330-900.

F_AC_050103_1_0060101_01_02

Typical Ramp Layout
Gate
FIGURE-5-1-3-991-006-A01

5-2-0 Terminal Operations - Full Servicing****ON A/C A330-300 A330-900**Terminal Operations – Full Servicing Turn Round Time

1. This section provides a typical turn round time chart showing the typical time for ramp activities during aircraft turn round.
Actual times may vary due to each operator's specific practices, resources, equipment and operating conditions.

2. Assumptions used for full servicing turn round time chart

A. PASSENGER HANDLING

300 pax: 36 B/C + 264 Y/C.

All passengers deplane and board the aircraft.

2 Passenger Boarding Bridges (PBB) used at doors 1L and 2L.

Equipment positioning + opening door = +2 min.

Closing door + equipment removal = +2 min.

No Passenger with Reduced Mobility (PRM) on board.

Deplaning:

- 150 pax at door 1L
- 150 pax at door 2L
- Deplaning rate = 25 pax/min per door
- Priority deplaning for premium passengers.

Boarding:

- 150 pax at door 1L
- 150 pax at door 2L
- Boarding rate = 15 pax/min per door
- Last Pax Seating allowance (LPS) + headcounting = +4 min.

B. CARGO

2 cargo loaders + 1 belt loader.

Opening door + equipment positioning = +2.5 min.

Equipment removal + closing door = +2.5 min.

100% cargo exchange:

- FWD cargo compartment: 18 containers
- AFT cargo compartment: 14 containers
- Bulk compartment: 1 000 kg (2 205 lb).

Container unloading/loading times:

- Unloading = 1.2 min/container
- Loading = 1.4 min/container.

Bulk unloading/loading times:

- Unloading = 110 kg/min (243 lb/min)
- Loading = 95 kg/min (209 lb/min).

C. REFUELING

Final fuel on board: 90 000 l (23 775 US gal) at 50 psig (3.45 bars-rel), 2 hoses.

Hydrant positioning + connection = +8 min.

Disconnection + hydrant removal = +8 min.

Refueling with pax on board allowed.

D. CLEANING

Cleaning is performed in available time.

E. CATERING

3 catering trucks for servicing galleys simultaneously at doors 1R, 2R and 4R.

Equipment positioning + opening door = +5 min.

Closing door + equipment removal = +3 min.

Full Size Trolley Equivalent (FSTE) to unload and load: 35 FSTE

- 4 FSTE at door 1R
- 9 FSTE at door 2R
- 22 FSTE at door 4R.

Time for trolley exchange = 1.5 min per FSTE.

F. GROUND HANDLING/GENERAL SERVICING

Start of operations:

- Bridges/Stairs: $t_0=0$
- Other equipment: $t = t_0$.

Ground Power Unit (GPU): up to 2×90 kVA.

Air Conditioning: up to 2 hoses.

Waste water servicing: draining + rinsing.

Potable water servicing: 100% uplift, 700 l (185 US gal).

**ON A/C A330-300 A330-900

TRT: 59 min

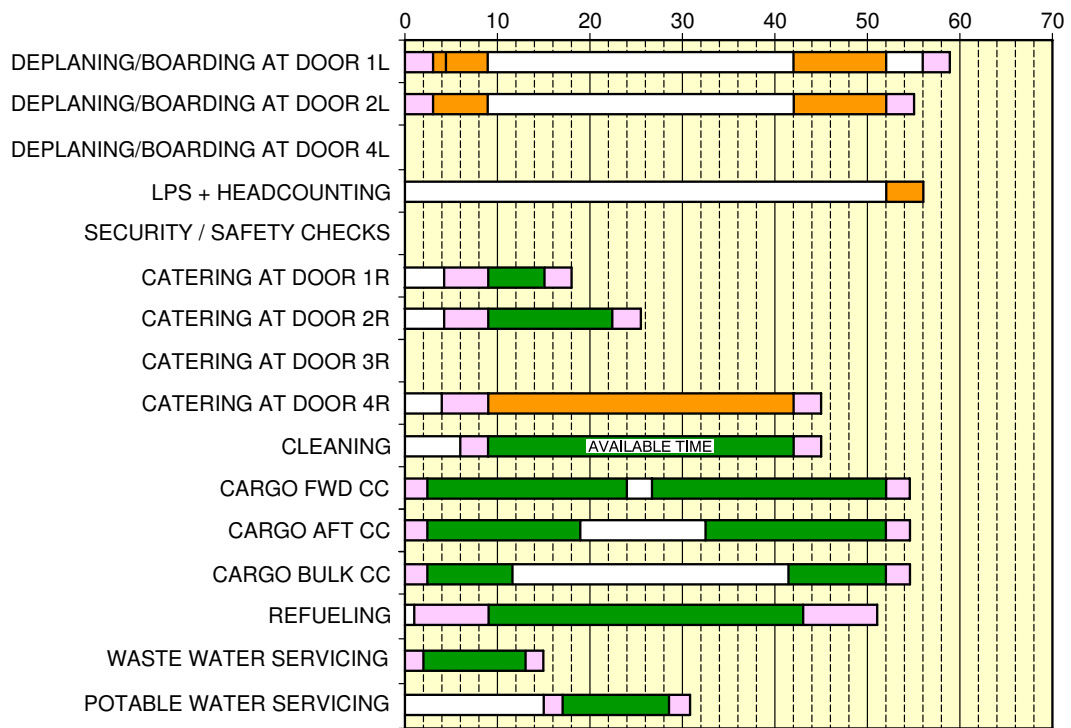

- GSE POSITIONING/REMOVAL
- ACTIVITY
- CRITICAL PATH

F_AC_050200_1_0010201_01_03

Full Servicing Turn Round Time Chart
FIGURE-5-2-0-991-001-B01

****ON A/C A330-200 A330-800**Terminal Operations – Full Servicing Turn Round Time

1. This section provides a typical turn round time chart showing the typical time for ramp activities during aircraft turn round.
Actual times may vary due to each operator's specific practices, resources, equipment and operating conditions.

2. Assumptions used for full servicing turn round time chart

A. PASSENGER HANDLING

246 pax: 36 B/C + 210 Y/C.

All passengers deplane and board the aircraft.

2 Passenger Boarding Bridges (PBB) used at doors 1L and 2L.

Equipment positioning + opening door = +2 min.

Closing door + equipment removal = +2 min.

No Passenger with Reduced Mobility (PRM) on board.

Deplaning:

- 123 pax at door 1L
- 123 pax at door 2L
- Deplaning rate = 25 pax/min per door
- Priority deplaning for premium passengers.

Boarding:

- 123 pax at door 1L
- 123 pax at door 2L
- Boarding rate = 15 pax/min per door
- Last Pax Seating allowance (LPS) + headcounting = +4 min.

B. CARGO

2 cargo loaders + 1 belt loader.

Opening door + equipment positioning = +2.5 min.

Equipment removal + closing door = +2.5 min.

100% cargo exchange:

- FWD cargo compartment: 14 containers
- AFT cargo compartment: 12 containers
- Bulk compartment: 1 000 kg (2 205 lb).

Container unloading/loading times:

- Unloading = 1.2 min/container
- Loading = 1.4 min/container.

Bulk unloading/loading times:

- Unloading = 110 kg/min (243 lb/min)
- Loading = 95 kg/min (209 lb/min).

C. REFUELING

Final fuel on board: 115 000 l (30 380 US gal) at 50 psig (3.45 bars-rel), 4 hoses.
Hydrant positioning + connection = +8 min.
Disconnection + hydrant removal = +8 min.
Refueling with pax on board allowed.

D. CLEANING

Cleaning is performed in available time.

E. CATERING

3 catering trucks for servicing galleys simultaneously at doors 1R, 2R and 4R.
Equipment positioning + opening door = +5 min.
Closing door + equipment removal = +3 min.

Full Size Trolley Equivalent (FSTE) to unload and load: 32 FSTE

- 8 FSTE at door 1R
- 4 FSTE at door 2R
- 20 FSTE at door 4R.

Time for trolley exchange = 1.5 min per FSTE.

F. GROUND HANDLING/GENERAL SERVICING

Start of operations:

- Bridges/Stairs: $t_0=0$
- Other equipment: $t = t_0$.

Ground Power Unit (GPU): up to 2×90 kVA.

Air Conditioning: up to 2 hoses.

Waste water servicing: draining + rinsing.

Potable water servicing: 100% uplift, 700 l (185 US gal).

**ON A/C A330-200 A330-800

TRT: 53 min

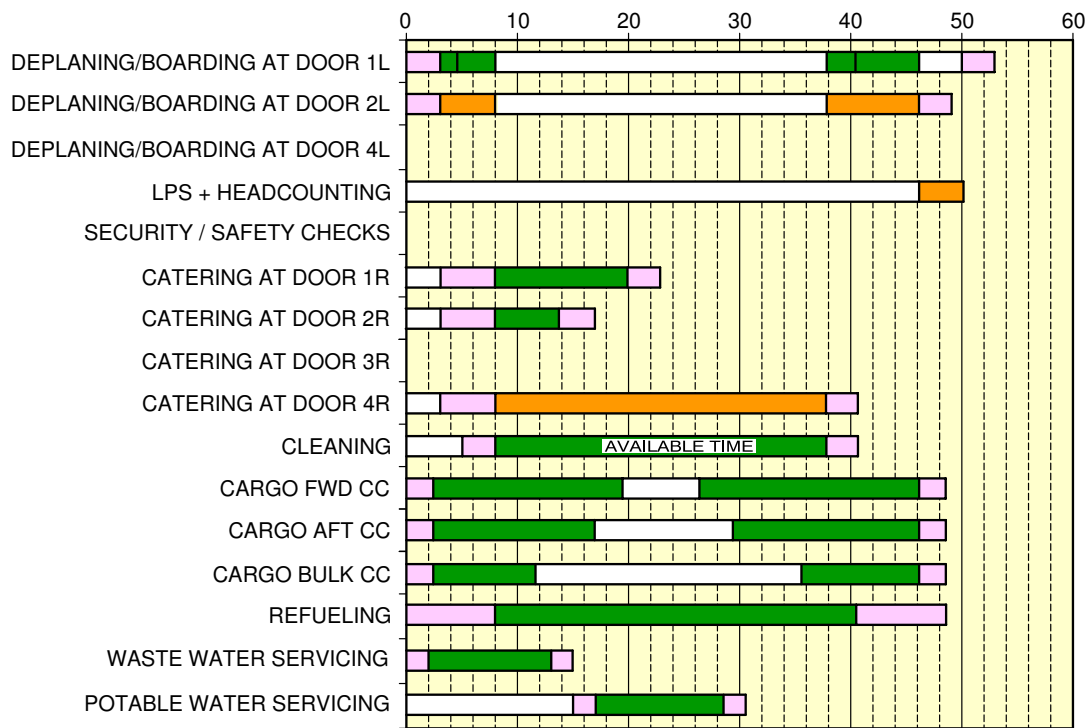

- GSE POSITIONING/REMOVAL
- ACTIVITY
- CRITICAL PATH

F_AC_050200_1_0080101_01_03

Full Servicing Turn Round Time Chart
FIGURE-5-2-0-991-008-A01

****ON A/C A330-200F**Terminal Operations - Full Servicing Turn Round Time

1. This section gives a typical turn round time chart showing the typical time for ramp activities during aircraft turn round.
Actual times may vary due to each operator's specific practices, resources, equipment and operating conditions.
2. Assumptions used for full servicing turn round time chart
 - A. CARGO
 - 4 Couriers.
Stairs positioned at door 1L for deplaning and boarding.

 - 2 cargo loaders + 1 belt loader.
Opening door + equipment positioning = +2.5 min.
Equipment removal + closing door = +2.5 min.
100% cargo exchange.

 - Main deck cargo compartment:
 - 23 containers (88" X 125").

 - Lower deck cargo compartments:
 - FWD cargo compartment: 6 pallets
 - AFT cargo compartment: 5 pallets
 - Bulk compartment: 1 000 kg (2 205 lb).

 - Container unloading/loading times:
 - Unloading = 1.2 min/container
 - Loading = 1.4 min/container.

 - Pallet unloading/loading times:
 - Unloading = 2.4 min/pallet
 - Loading = 2.8 min/pallet.

 - Bulk unloading/loading times:
 - Unloading = 110 kg/min (243 lb/min)
 - Loading = 95 kg/min (209 lb/min).
 - B. REFUELING
 - Final fuel on board: 50 000 l (13 209 US gal) at 50 psig (3.45 bars-rel), 2 hoses.
 - Hydrant positioning + connection = +8 min.
 - Disconnection + hydrant removal = +8 min.
 - C. CLEANING
 - Courier area cleaning is performed in available time.

D. CATERING

Catering of galley (if installed) is performed through door 1L (standard units only) and in available time.

E. GROUND HANDLING/GENERAL SERVICING

Start of operations:

- Stairs: $t_0 = 0$
- Other equipment: $t = t_0$.

Ground Power Unit (GPU): up to 2 x 90 kVA.

Air Conditioning: up to 2 hoses.

Waste water servicing: draining + rinsing.

Potable water servicing: 100% uplift, 100 l (26.4 US gal).

**ON A/C A330-200F

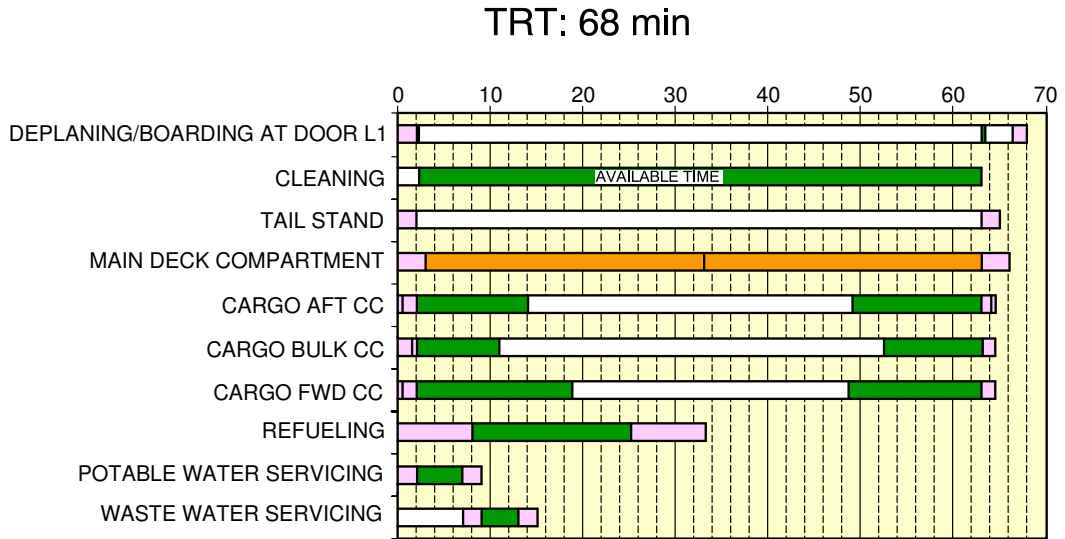

- GSE POSITIONING/REMOVAL
- ACTIVITY
- CRITICAL PATH

F_AC_050200_1_0090101_01_04

Full Servicing Turn Round Time Chart
FIGURE-5-2-0-991-009-A01

5-3-0 Terminal Operations - Transit****ON A/C A330-300 A330-900**Terminal Operations - Transit Turn Round Time

1. This section provides a typical turn round time chart showing the typical time for ramp activities during aircraft turn round.
Actual times may vary due to each operator's specific practices, resources, equipment and operating conditions.

2. Assumptions used for transit turn round time chart

A. PASSENGER HANDLING

300 pax (36 B/C + 264 Y/C).

50% of passengers deplane and board the aircraft.

1 Passenger Boarding Bridge (PBB) used at door 1L.

Equipment positioning/removal + opening/closing door = +3 min.

No Passenger with Reduced Mobility (PRM) on board.

Deplaning:

- 150 pax at door 1L

- Deplaning rate = 25 pax/min per door.

Boarding:

- 150 pax at door 1L

- Boarding rate = 15 pax/min per door

- Last Pax Seating allowance (LPS) + headcounting = +4 min.

B. CARGO

1 cargo loader and 1 belt loader.

Equipment positioning/removal + opening/closing door = +2.5 min.

50% cargo exchange:

- AFT cargo compartment: 7 containers

- Bulk compartment: 500 kg (1 102 lb).

Container unloading/loading times:

- Unloading = 1.2 min/container

- Loading = 1.4 min/container.

Bulk unloading/loading times:

- Unloading = 110 kg/min (242.5 lb/min)

- Loading = 95 kg/min (209.4 lb/min).

C. REFUELING

No refueling.

D. CLEANING

Cleaning is performed in available time.

E. CATERING

One catering truck for servicing the galleys as required.

F. GROUND HANDLING/GENERAL SERVICING

Start of operations:

- Bridges/stairs: $t_0 = 0$
- Other equipment: $t = t_0$.

Ground Power Unit (GPU): up to 2×90 kVA.

Air conditioning: up to 2 hoses.

No toilet servicing.

No potable water servicing.

**ON A/C A330-300 A330-900

TRT: 34 min

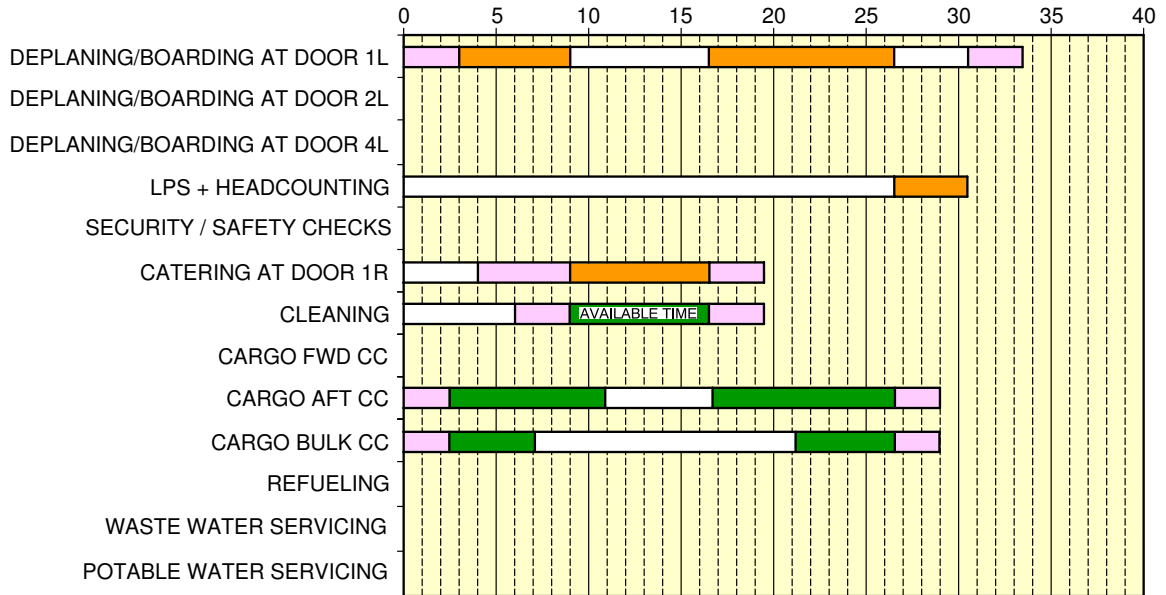

- GSE POSITIONING/REMOVAL
- ACTIVITY
- CRITICAL PATH

F_AC_050300_1_0010201_01_02

Transit Turn Round Time Chart
FIGURE-5-3-0-991-001-B01

****ON A/C A330-200 A330-800**Terminal Operations - Transit Turn Round Time

1. This section provides a typical turn round time chart showing the typical time for ramp activities during aircraft turn round.
Actual times may vary due to each operator's specific practices, resources, equipment and operating conditions.
2. Assumptions used for transit turn round time chart
 - A. PASSENGER HANDLING
246 pax (36 B/C + 210 Y/C).
50% of passengers deplane and board the aircraft.
1 Passenger Boarding Bridge (PBB) used at door 1L.
Equipment positioning/removal + opening/closing door = +3 min.
No Passenger with Reduced Mobility (PRM) on board.

Deplaning:
 - 123 pax at door 1L
 - Deplaning rate = 25 pax/min per door.
Boarding:
 - 123 pax at door 1L
 - Boarding rate = 15 pax/min per door
 - Last Pax Seating allowance (LPS) + headcounting = +4 min.
 - B. CARGO
1 cargo loader and 1 belt loader.
Equipment positioning/removal + opening/closing door = +2.5 min.

50% cargo exchange:
 - AFT cargo compartment: 6 containers
 - Bulk compartment: 500 kg (1 102 lb).
Container unloading/loading times:
 - Unloading = 1.2 min/container
 - Loading = 1.4 min/container.
Bulk unloading/loading times:
 - Unloading = 110 kg/min (242.5 lb/min)
 - Loading = 95 kg/min (209.4 lb/min).
 - C. REFUELING
No refueling.

D. CLEANING

Cleaning is performed in available time.

E. CATERING

One catering truck for servicing the galleys as required.

F. GROUND HANDLING/GENERAL SERVICING

Start of operations:

- Bridges/stairs: $t_0 = 0$
- Other equipment: $t = t_0$.

Ground Power Unit (GPU): up to 2×90 kVA.

Air conditioning: up to 2 hoses.

No toilet servicing.

No potable water servicing.

**ON A/C A330-200 A330-800

TRT: 31 min

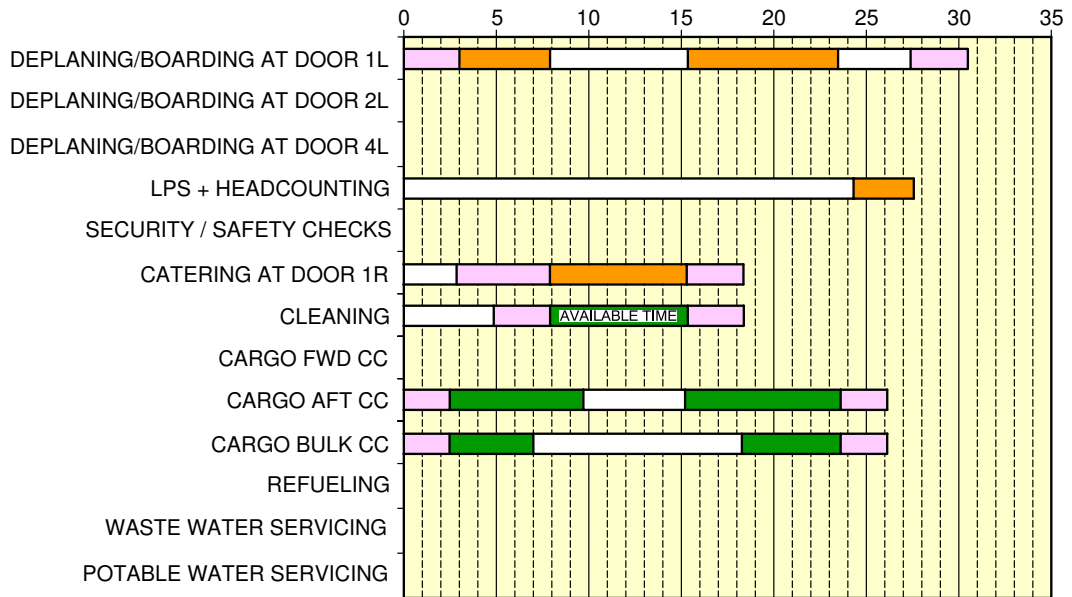

- GSE POSITIONING/REMOVAL
- ACTIVITY
- CRITICAL PATH

F_AC_050300_1_0040101_01_02

Transit Turn Round Time Chart
FIGURE-5-3-0-991-004-A01



5-4-1 Ground Service Connections Layout

****ON A/C A330-200 A330-300 A330-800 A330-900**

Ground Service Connections Layout

1. This section gives the ground service-connections layout.

**ON A/C A330-200 A330-300

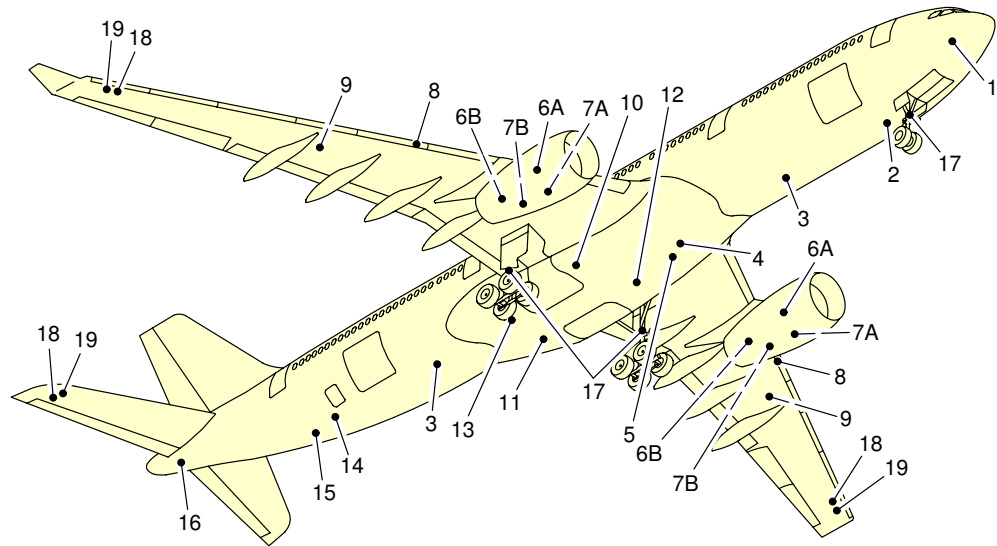

- | | |
|--|--|
| 1 - OXYGEN SERVICING | 10 - HYDRAULIC GROUND POWER SUPPLY (YELLOW) |
| 2 - GROUND ELECTRICAL POWER CONNECTORS | 11 - HYDRAULIC RESERVOIR FILLING AND GROUND POWER SUPPLY (GREEN) |
| 3 - POTABLE WATER DRAIN | 12 - HYDRAULIC RESERVOIR AIR PRESSURIZATION AND GROUND POWER SUPPLY (BLUE) |
| 4 - LOW PRESSURE AIR PRE-CONDITIONING | 13 - REFUEL/DEFUEL PANEL |
| 5 - HIGH PRESSURE AIR PRE-CONDITIONING AND ENGINE STARTING | 14 - POTABLE WATER SERVICE PANEL |
| 6A - ENGINE OIL FILLING (FOR RR AND GE) | 15 - WASTE WATER SERVICE PANEL |
| 6B - ENGINE OIL FILLING (FOR PW) | 16 - APU OIL FILLING |
| 7A - IDG OIL FILLING (FOR RR) | 17 - GROUNDING (EARTHING) POINT |
| 7B - IDG OIL FILLING (FOR PW AND GE) | 18 - NACA FLAME ARRESTOR |
| 8 - PRESSURE REFUEL/DEFUEL COUPLINGS | 19 - OVERPRESSURE PROTECTOR |
| 9 - OVERWING REFUEL (IF INSTALLED) | |

F_AC_050401_1_0010101_01_03

Ground Service-Connections Layout
FIGURE-5-4-1-991-001-A01

****ON A/C A330-800 A330-900**

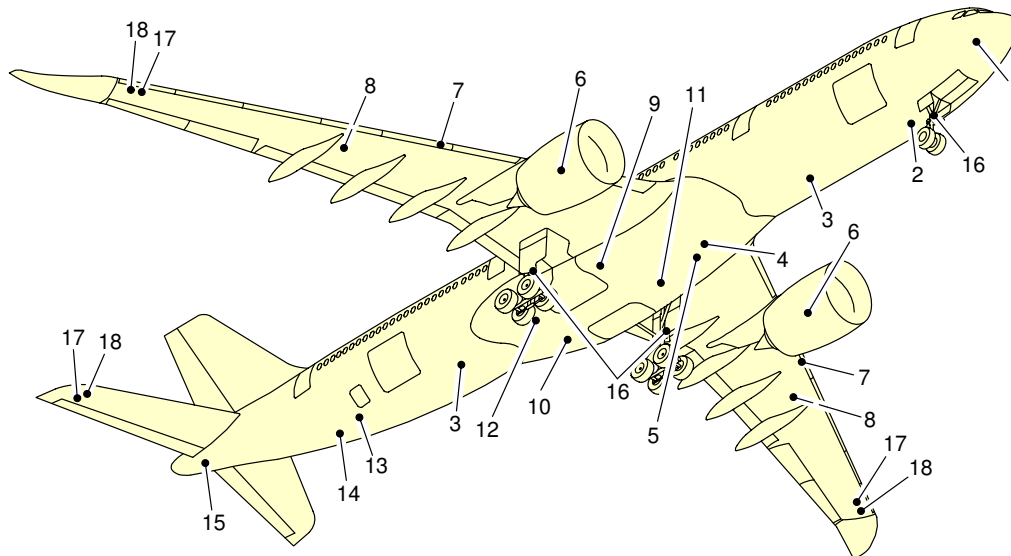

- | | |
|--|--|
| 1 – OXYGEN SERVICING | 10 – HYDRAULIC RESERVOIR FILLING AND GROUND POWER SUPPLY (GREEN) |
| 2 – GROUND ELECTRICAL-POWER CONNECTORS | 11 – HYDRAULIC-RESERVOIR AIR PRESSURIZATION AND GROUND POWER SUPPLY (BLUE) |
| 3 – POTABLE WATER DRAIN | 12 – REFUEL/DEFUEL PANEL |
| 4 – LOW-PRESSURE AIR PRE-CONDITIONING | 13 – POTABLE WATER SERVICE-PANEL |
| 5 – HIGH-PRESSURE AIR PRE-CONDITIONING AND ENGINE STARTING | 14 – WASTE WATER SERVICE-PANEL |
| 6 – ENGINE OIL FILLING | 15 – APU OIL FILLING |
| 7 – PRESSURE REFUEL/DEFUEL COUPLINGS | 16 – GROUNDING (EARTHING) POINT |
| 8 – OVERWING REFUEL (IF INSTALLED) | 17 – NACA FLAME ARRESTOR |
| 9 – HYDRAULIC GROUND-POWER SUPPLY (YELLOW) | 18 – OVERPRESSURE PROTECTOR |

NOTE:

TO GET ACCESS TO THE IDG AND THE ENGINE PNEUMATIC STARTER, OPEN THE FAN COWLS,
SEE AMM 12-13-24 AND SEE AMM 12-13-80

F_AC_050401_1_0080101_01_00

Ground Service-Connections Layout
FIGURE-5-4-1-991-008-A01



****ON A/C A330-200F**

Ground Service Connections Layout

1. This section provides the ground service connections layout.

**ON A/C A330-200F

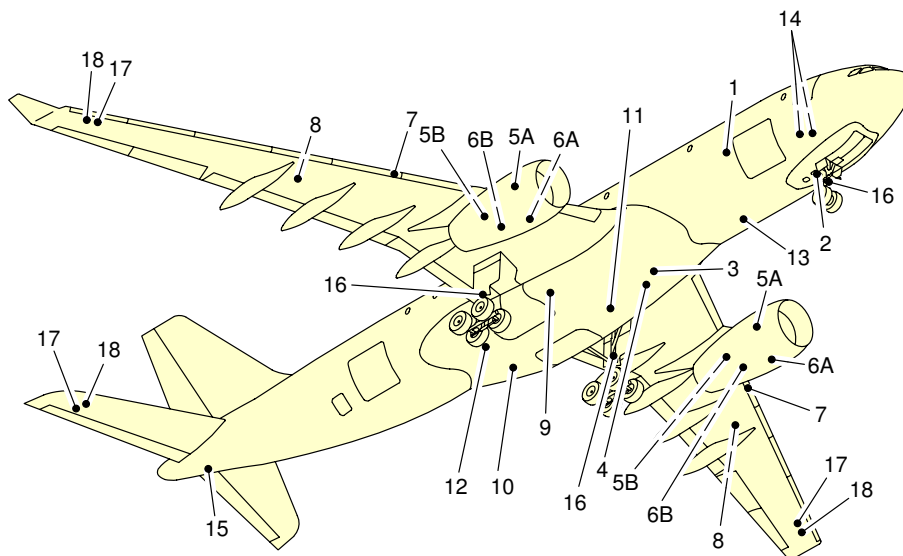

- | | |
|--|--|
| 1 – OXYGEN SERVICING | 10 – HYDRAULIC RESERVOIR FILLING AND GROUND POWER SUPPLY (GREEN) |
| 2 – GROUND ELECTRICAL POWER CONNECTORS | 11 – HYDRAULIC RESERVOIR AIR PRESSURIZATION AND GROUND POWER SUPPLY (BLUE) |
| 3 – LOW PRESSURE AIR PRE-CONDITIONING | 12 – REFUEL/DEFUEL PANEL |
| 4 – HIGH PRESSURE AIR PRE-CONDITIONING AND ENGINE STARTING | 13 – POTABLE WATER SERVICE PANEL |
| 5A – ENGINE OIL FILLING (FOR RR) | 14 – WASTE WATER SERVICE PANEL |
| 5B – ENGINE OIL FILLING (FOR PW) | 15 – APU OIL FILLING |
| 6A – IDG OIL FILLING (FOR RR) | 16 – GROUNDING (EARTHING) POINT |
| 6B – IDG OIL FILLING (FOR PW) | 17 – NACA FLAME ARRESTOR |
| 7 – PRESSURE REFUEL/DEFUEL COUPLINGS | 18 – OVERPRESSURE PROTECTOR |
| 8 – OVERWING REFUEL (IF INSTALLED) | |
| 9 – HYDRAULIC GROUND POWER SUPPLY (YELLOW) | |

F_AC_050401_1_0020101_01_04

Ground Service Connections Layout
FIGURE-5-4-1-991-002-A01

5-4-2 Grounding Points

****ON A/C A330-200 A330-200F A330-300 A330-800 A330-900**

Grounding (Earthing) Points

****ON A/C A330-300 A330-900**

1. Grounding (Earthing) Points

NOTE : The mean height from ground in the below table may change according to the CG position and aircraft weight.

ACCESS	DISTANCE			MEAN HEIGHT FROM GROUND
	AFT OF NOSE	FROM AIRCRAFT CENTERLINE		
		LH SIDE	RH SIDE	
On Nose Landing Gear leg:	6.67 m (21.88 ft)	On centerline		1.40 m (4.59 ft)
On left Main Landing Gear leg:	31.53 m (103.44 ft)	5.34 m (17.52 ft)		1.50 m (4.92 ft)
On right Main Landing Gear leg:	31.53 m (103.44 ft)		5.34 m (17.52 ft)	1.50 m (4.92 ft)

- A. The grounding (earthing) stud on each landing gear leg is designed for use with a clip-on connector (such as Appleton TGR).
- B. The grounding (earthing) studs are used to connect the aircraft to an approved ground (earth) connection on the ramp or in the hangar for:
 - Refuel/defuel operations
 - Maintenance operations
 - Bad weather conditions.

NOTE : In all other conditions, the electrostatic discharge through the tire is sufficient.

****ON A/C A330-200 A330-200F A330-800**

2. Grounding (Earthing) Points

NOTE : The mean height from ground in the below table may change according to the CG position and aircraft weight.

ACCESS	DISTANCE			
	AFT OF NOSE	FROM AIRCRAFT CENTERLINE		MEAN HEIGHT FROM GROUND
		LH SIDE	RH SIDE	
On Nose Landing Gear leg:	6.67 m (21.88 ft)	On centerline		1.40 m (4.59 ft)
On left Main Landing Gear leg:	28.37 m (93.08 ft)	5.34 m (17.52 ft)		1.50 m (4.92 ft)
On right Main Landing Gear leg:	28.37 m (93.08 ft)		5.34 m (17.52 ft)	1.50 m (4.92 ft)

- A. The grounding (earthing) stud on each landing gear leg is designed for use with a clip-on connector (such as Appleton TGR).
- B. The grounding (earthing) studs are used to connect the aircraft to an approved ground (earth) connection on the ramp or in the hangar for:
 - Refuel/defuel operations
 - Maintenance operations
 - Bad weather conditions.

NOTE : In all other conditions, the electrostatic discharge through the tire is sufficient.

**ON A/C A330-200 A330-200F A330-300 A330-800 A330-900

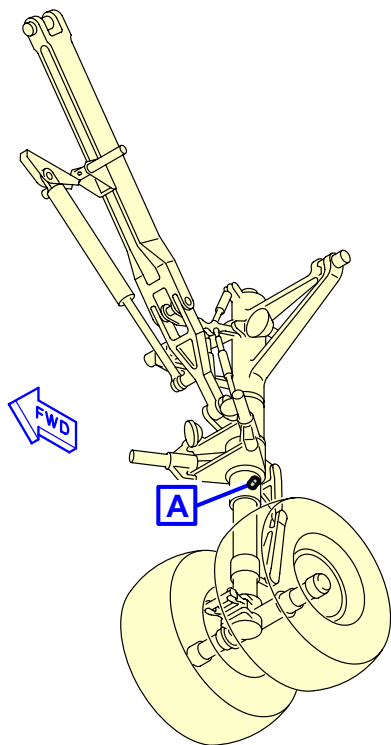

NOSE LANDING GEAR

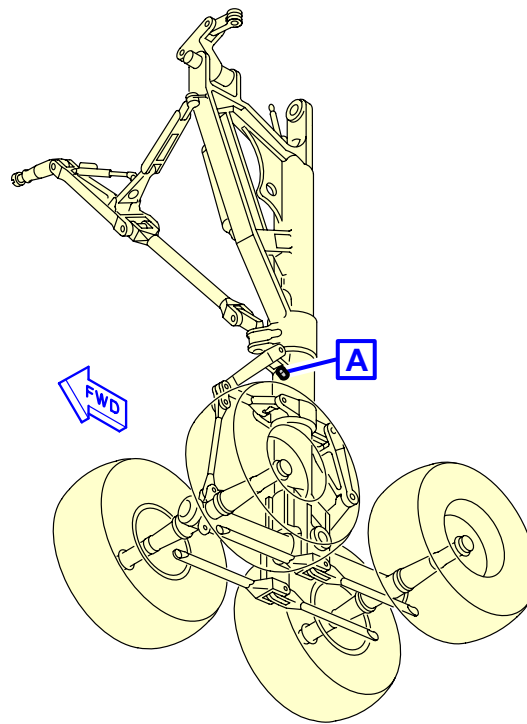

MAIN LANDING GEAR

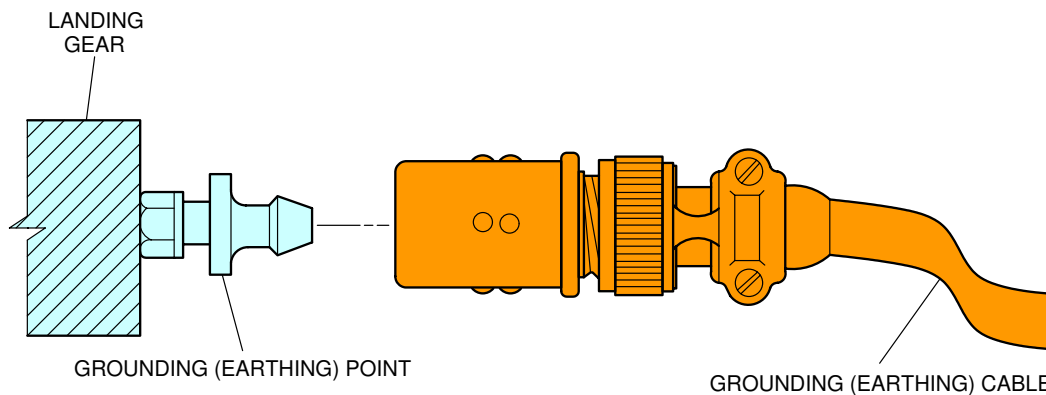

A

TYPICAL

F_AC_050402_1_0010101_01_01

Ground Service Connections
Grounding (Earthing) Points
FIGURE-5-4-2-991-001-A01

**ON A/C A330-200 A330-200F A330-300 A330-800 A330-900

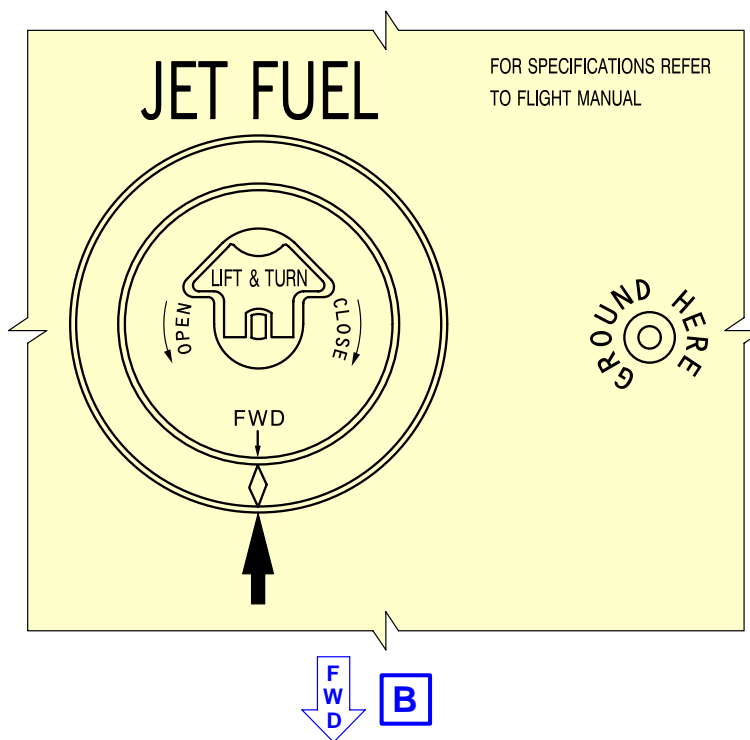
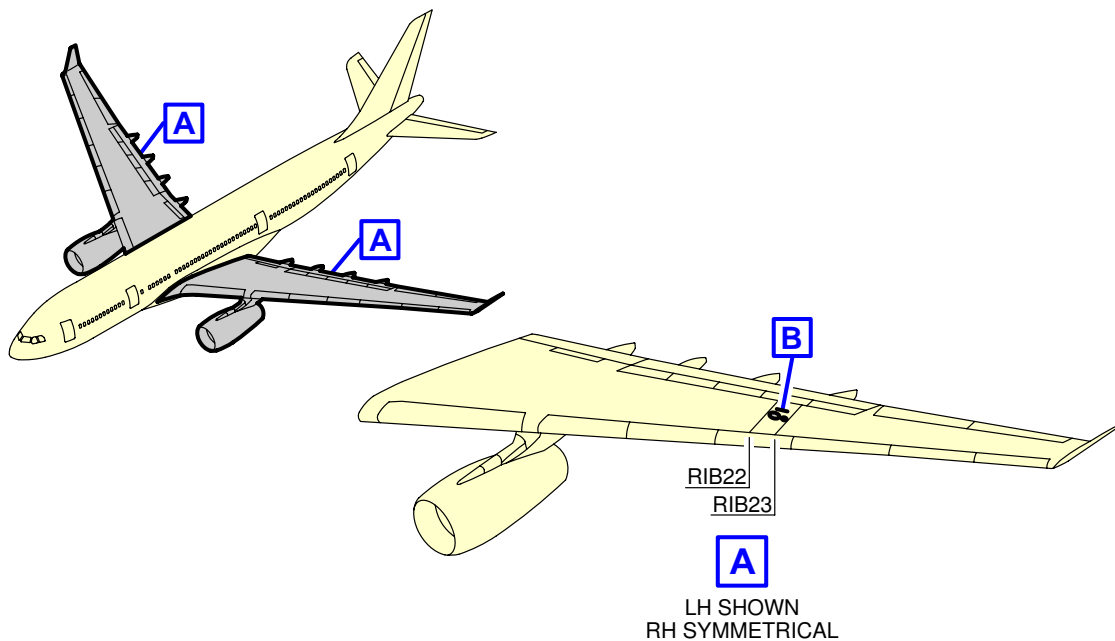

F_AC_050402_1_0020101_01_01

Ground Service Connections
Grounding (Earthing) Points
FIGURE-5-4-2-991-002-A01

5-4-3 Hydraulic System

****ON A/C A330-200 A330-200F A330-300 A330-800 A330-900**

Hydraulic Servicing

****ON A/C A330-300 A330-900**

1. Ground Service Panels

NOTE : The mean height from ground in the below table may change according to the CG position and aircraft weight.

ACCESS	DISTANCE			MEAN HEIGHT FROM GROUND
	AFT OF NOSE	FROM AIRCRAFT CENTERLINE		
		LH SIDE	RH SIDE	
Green System: Access Door 197CB	34.90 m (114.50 ft)	1.34 m (4.40 ft)		2.23 m (7.32 ft)
Yellow System: Access Door 196BB	29.00 m (95.14 ft)		1.30 m (4.27 ft)	1.95 m (6.40 ft)
Blue System: Access Door 195BB	28.00 m (91.86 ft)	1.28 m (4.20 ft)		1.94 m (6.36 ft)

****ON A/C A330-200 A330-200F A330-800**

2. Ground Service Panels

NOTE : The mean height from ground in the below table may change according to the CG position and aircraft weight.

ACCESS	DISTANCE			MEAN HEIGHT FROM GROUND
	AFT OF NOSE	FROM AIRCRAFT CENTERLINE		
		LH SIDE	RH SIDE	
Green System: Access Door 197CB	31.60 m (103.67 ft)	1.34 m (4.40 ft)		2.23 m (7.32 ft)
Yellow System: Access Door 196BB	25.80 m (84.65 ft)		1.30 m (4.27 ft)	1.95 m (6.40 ft)
Blue System: Access Door 195BB	24.70 m (81.04 ft)	1.28 m (4.20 ft)		1.94 m (6.36 ft)

****ON A/C A330-200 A330-200F A330-300 A330-800 A330-900**

3. Reservoir Pressurization
 One 1/4 in. self-sealing connection common to the 3 reservoirs.

NOTE : The mean height from ground in the below table may change according to the CG position and aircraft weight.

ACCESS	DISTANCE			MEAN HEIGHT FROM GROUND
	AFT OF NOSE	FROM AIRCRAFT CENTERLINE		
		LH SIDE	RH SIDE	
Blue System Ground Service Panel: Access Door 195BB	34.47 m (113.09 ft)	1.41 m (4.63 ft)		1.89 m (6.20 ft)

****ON A/C A330-300 A330-900**

4. Accumulator Charging
 Five connections (one for each accumulator):

NOTE : The mean height from ground in the below table may change according to the CG position and aircraft weight.

ACCESS	DISTANCE			MEAN HEIGHT FROM GROUND
	AFT OF NOSE	FROM AIRCRAFT CENTERLINE		
		LH SIDE	RH SIDE	
Green System Accumulator: Access Door 197CB	41.52 m (136.22 ft)	1.33 m (4.36 ft)		2.19 m (7.19 ft)
Yellow System Accumulator: Access Door 196BB	35.55 m (116.63 ft)		1.43 m (4.69 ft)	1.91 m (6.27 ft)
Blue System Accumulator: Access Door 195BB	34.54 m (113.32 ft)	1.38 m (4.53 ft)		1.90 m (6.23 ft)
Blue System Brake Accumulator: Access Door 195BB	34.54 m (113.32 ft)	1.18 m (3.87 ft)		1.90 m (6.23 ft)

****ON A/C A330-200 A330-200F A330-800**

5. Accumulator Charging
Five connections (one for each accumulator):

NOTE : The mean height from ground in the below table may change according to the CG position and aircraft weight.

ACCESS	DISTANCE			
	AFT OF NOSE	FROM AIRCRAFT CENTERLINE		MEAN HEIGHT FROM GROUND
		LH SIDE	RH SIDE	
Green System Accumulator: Access Door 197CB	41.52 m (136.22 ft)	1.33 m (4.36 ft)		2.19 m (7.19 ft)
Yellow System Accumulator: Access Door 196BB	35.55 m (116.63 ft)		1.43 m (4.69 ft)	1.91 m (6.27 ft)
Blue System Accumulator: Access Door 195BB	34.54 m (113.32 ft)	1.38 m (4.53 ft)		1.90 m (6.23 ft)
Blue System Brake Accumulator: Access Door 195BB	34.54 m (113.32 ft)	1.24 m (4.07 ft)		1.90 m (6.23 ft)

****ON A/C A330-200 A330-200F A330-300 A330-800 A330-900**

6. Reservoir Filling
Two connections (one self-sealing connection for pressurized supply on the Green system ground service panel).

NOTE : The mean height from ground in the below table may change according to the CG position and aircraft weight.

ACCESS	DISTANCE			
	AFT OF NOSE	FROM AIRCRAFT CENTERLINE		MEAN HEIGHT FROM GROUND
		LH SIDE	RH SIDE	
One handpump filling connection: Access Door 197CB	41.31 m (135.53 ft)	1.30 m (4.27 ft)		2.11 m (6.92 ft)

7. Reservoir Drain

One 3/8 in. self-sealing connection on the reservoir for:

NOTE : The mean height from ground in the below table may change according to the CG position and aircraft weight.

ACCESS	DISTANCE			
	AFT OF NOSE	FROM AIRCRAFT CENTERLINE		MEAN HEIGHT FROM GROUND
		LH SIDE	RH SIDE	
Green System	33.17 m (108.83 ft)	0.70 m (2.30 ft)		3.80 m (12.47 ft)
Yellow System	29.03 m (95.24 ft)		2.12 m (6.96 ft)	2.40 m (7.87 ft)
Blue System	29.03 m (95.24 ft)	2.12 m (6.96 ft)		2.40 m (7.87 ft)

8. Ground Test

Three 1 in. self-sealing connections and three 1-1/2 in. self-sealing connections (one pair per system).

NOTE : The mean height from ground in the below table may change according to the CG position and aircraft weight.

ACCESS	DISTANCE			
	AFT OF NOSE	FROM AIRCRAFT CENTERLINE		MEAN HEIGHT FROM GROUND
		LH SIDE	RH SIDE	
Green System Ground Service Panel: Access Door 197CB	34.92 m (114.57 ft)	1.35 m (4.43 ft)		2.20 m (7.22 ft)
Yellow System Ground Service Panel: Access Door 196BB	29.03 m (95.24 ft)		1.30 m (4.27 ft)	2.00 m (6.56 ft)
Blue System Ground Service Panel: Access Door 195BB	28.03 m (91.96 ft)	1.28 m (4.20 ft)		2.00 m (6.56 ft)

****ON A/C A330-300 A330-900**

9. A/C Emergency Generation

NOTE : The mean height from ground in the below table may change according to the CG position and aircraft weight.

ACCESS	DISTANCE			
	AFT OF NOSE	FROM AIRCRAFT CENTERLINE		MEAN HEIGHT FROM GROUND
		LH SIDE	RH SIDE	
RAT Safety-Pin Installation: Access Panel 633SL	34.40 m (112.86 ft)		14.20 m (46.59 ft)	4.35 m (14.27 ft)

****ON A/C A330-200 A330-800**

10. A/C Emergency Generation

NOTE : The mean height from ground in the below table may change according to the CG position and aircraft weight.

ACCESS	DISTANCE			
	AFT OF NOSE	FROM AIRCRAFT CENTERLINE		MEAN HEIGHT FROM GROUND
		LH SIDE	RH SIDE	
RAT Safety-Pin Installation: Access Panel 633SL	31.40 m (103.02 ft)		14.20 m (46.59 ft)	4.35 m (14.27 ft)

****ON A/C A330-200F**

11. A/C Emergency Generation

NOTE : The mean height from ground in the below table may change according to the CG position and aircraft weight.

ACCESS	DISTANCE			
	AFT OF NOSE	FROM AIRCRAFT CENTERLINE		MEAN HEIGHT FROM GROUND
		LH SIDE	RH SIDE	
RAT Safety-Pin Installation: Access Panel 633SL	31.40 m (103.02 ft)		14.20 m (46.59 ft)	4.35 m (14.27 ft)

****ON A/C A330-200 A330-200F A330-300 A330-800 A330-900**

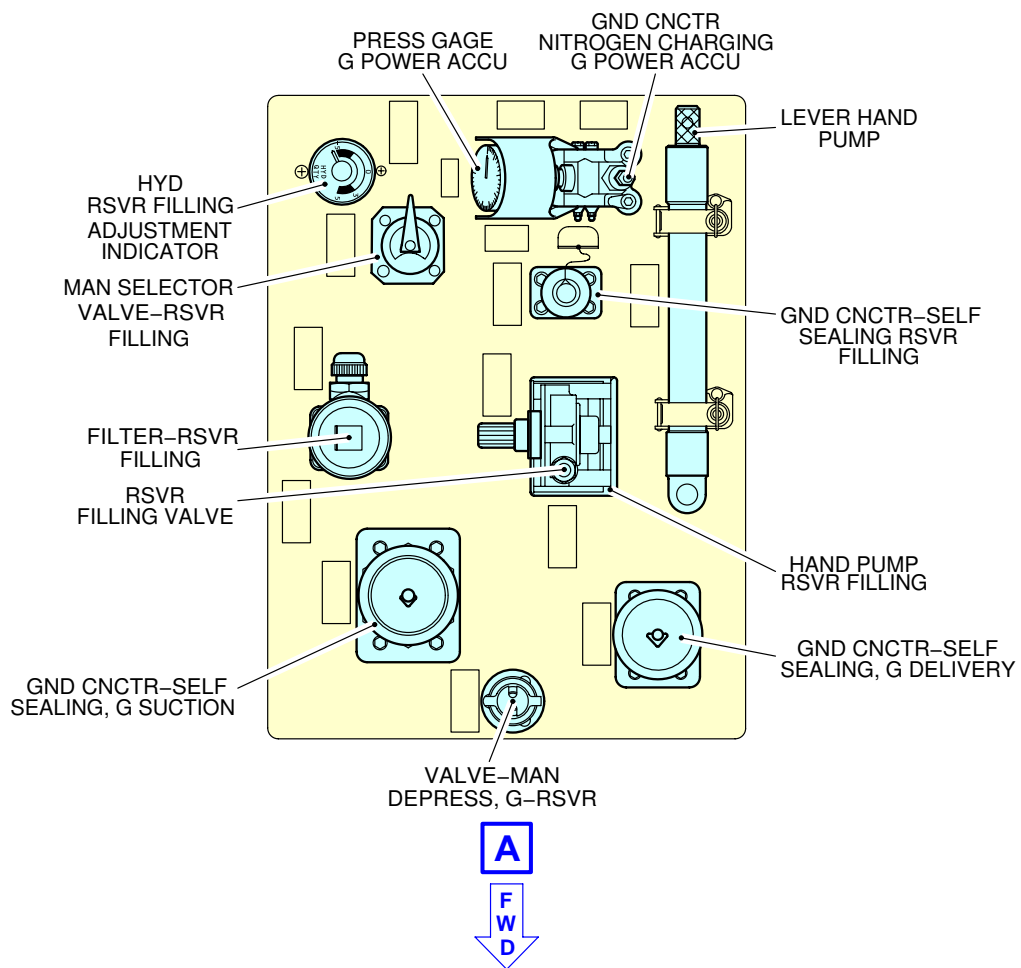
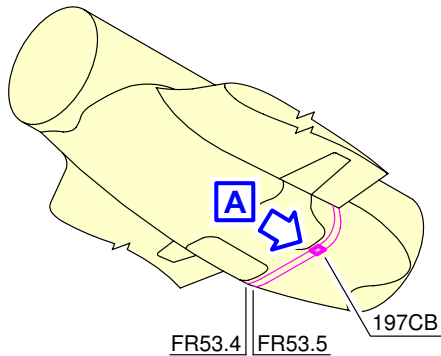

F_AC_050403_1_0010101_01_00

Ground Service Connections
Green System Ground Service Panel
FIGURE-5-4-3-991-001-A01

****ON A/C A330-200 A330-200F A330-300 A330-800 A330-900**

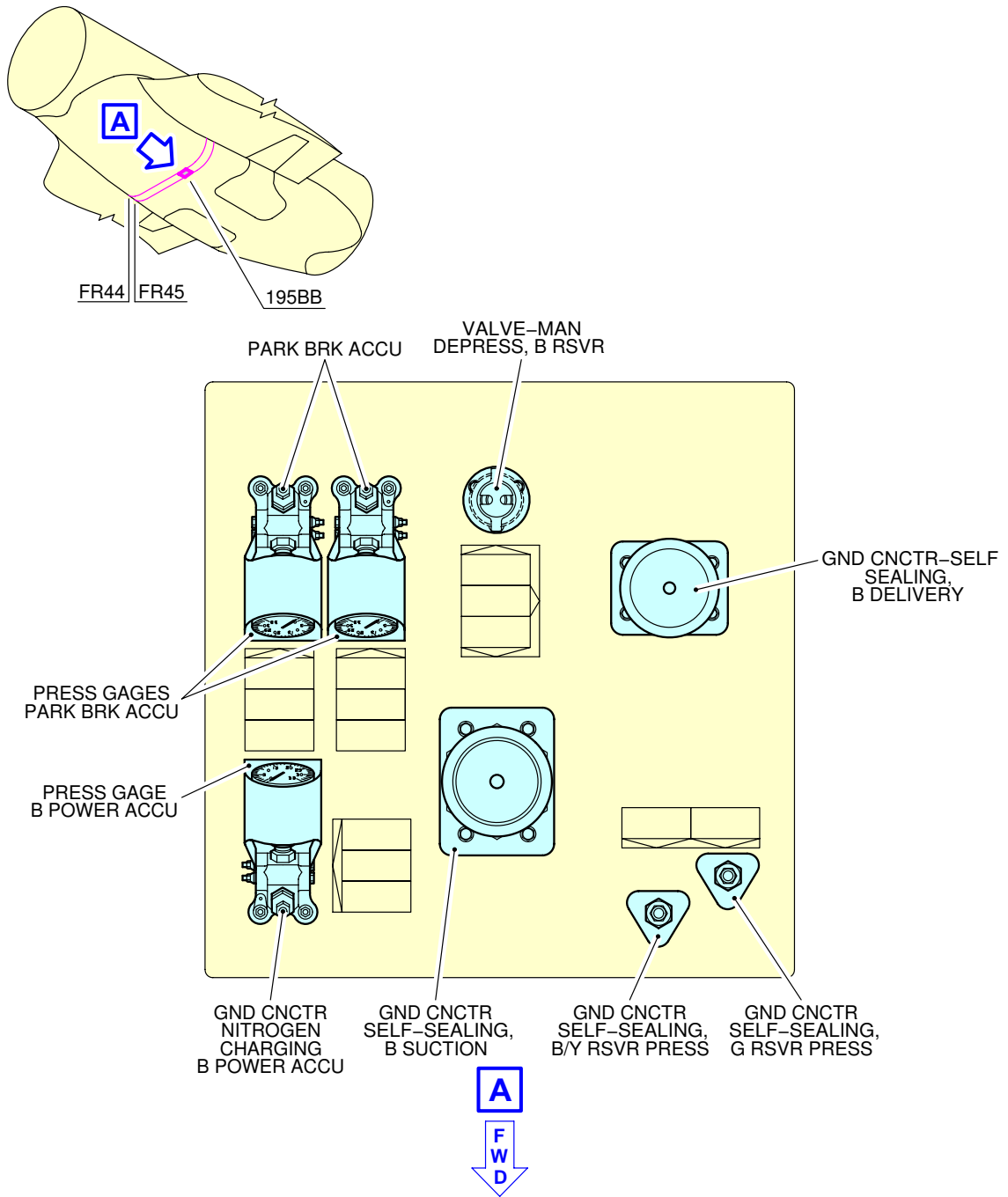

F_AC_050403_1_0020101_01_00

Ground Service Connections
 Blue System Ground Service Panel
 FIGURE-5-4-3-991-002-A01

**ON A/C A330-200 A330-200F A330-300 A330-800 A330-900

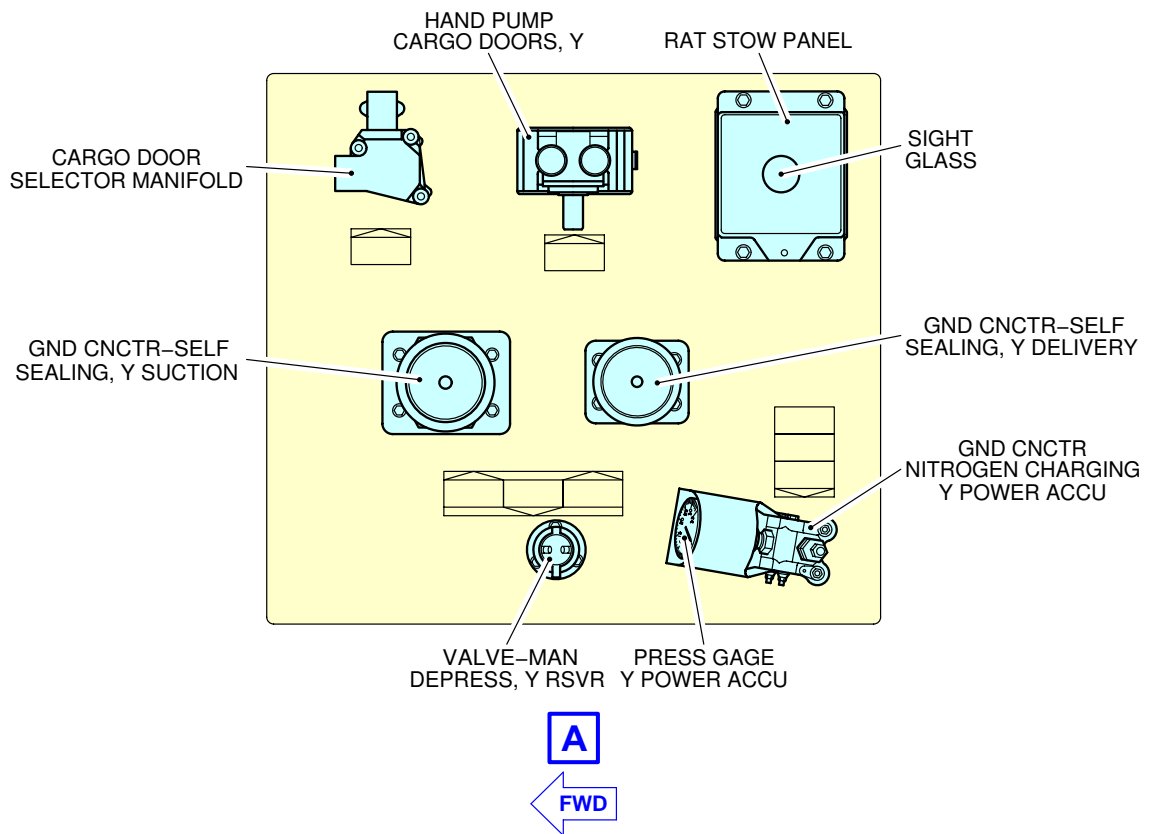
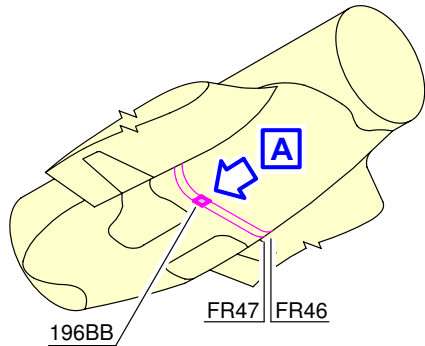

F_AC_050403_1_0030101_01_00

Ground Service Connections
 Yellow System Ground Service Panel
 FIGURE-5-4-3-991-003-A01

**ON A/C A330-200 A330-200F A330-300 A330-800 A330-900

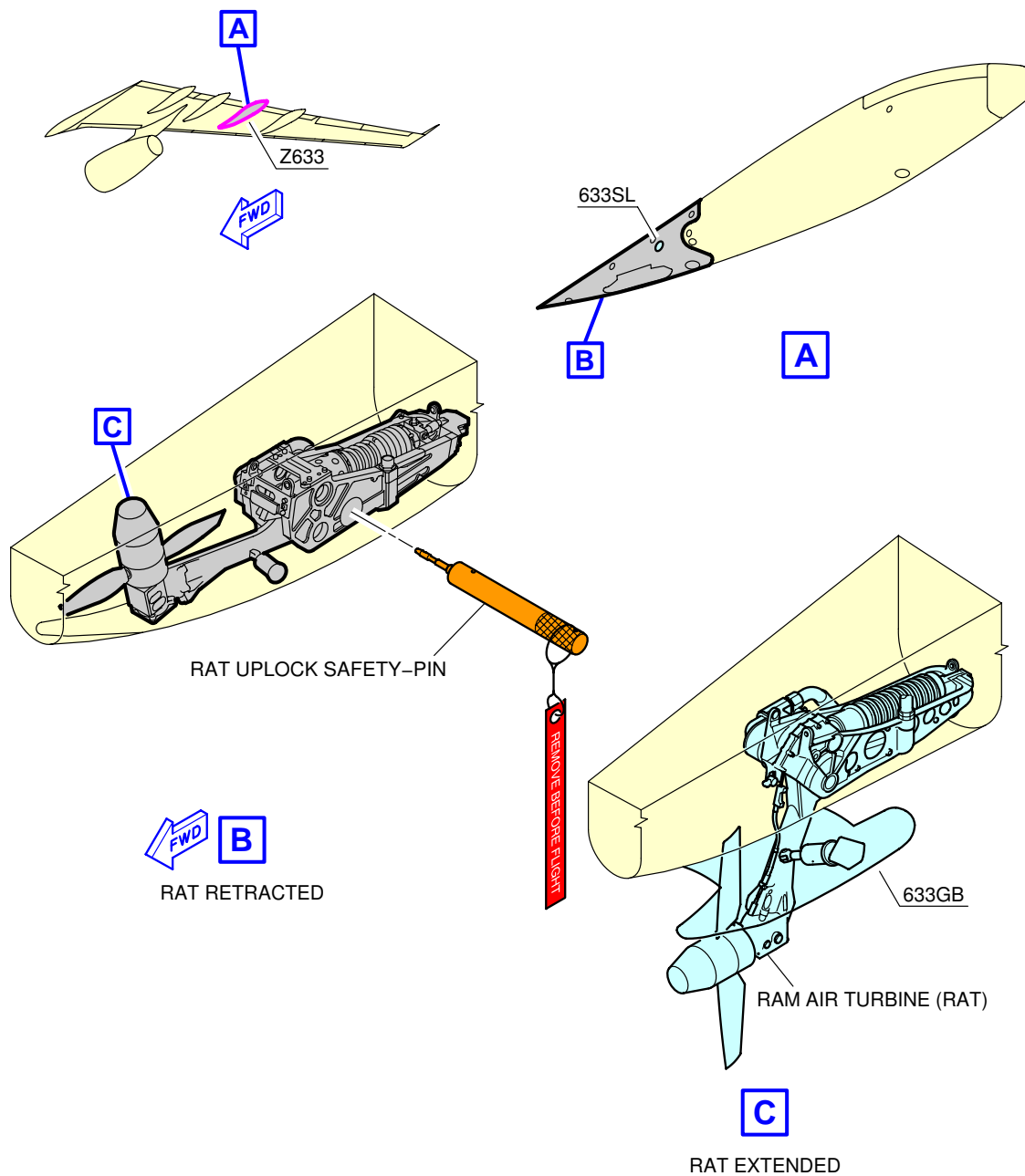

F_AC_050403_1_0100101_01_00

Ground Service Connections
RAT
FIGURE-5-4-3-991-010-A01

5-4-4 Electrical System

****ON A/C A330-200 A330-200F A330-300 A330-800 A330-900**

Electrical Servicing

****ON A/C A330-200 A330-300 A330-800 A330-900**

1. A/C External Power

NOTE : The mean height from ground in the below table may change according to the CG position and aircraft weight.

ACCESS	DISTANCE			MEAN HEIGHT FROM GROUND
	AFT OF NOSE	FROM AIRCRAFT CENTERLINE		
		LH SIDE	RH SIDE	
A/C External Power: Access Door 121EL	7.20 m (23.62 ft)	On centerline		1.98 m (6.50 ft)

NOTE : Distances are approximate.

2. Technical Specifications

- A. External Power Receptacles:
 - Two receptacles according to MS 90362-3 - 90 kVA.
- B. Power Supply:
 - Three-phase, 115 V, 400 Hz.
- C. Electrical Connectors for Servicing:
 - AC outlets: HUBBELL 5258
 - DC outlets: HUBBELL 7472.

3. Tow Truck Power

NOTE : The mean height from ground in the below table may change according to the CG position and aircraft weight.

ACCESS	DISTANCE			MEAN HEIGHT FROM GROUND
	AFT OF NOSE	FROM AIRCRAFT CENTERLINE		
		LH SIDE	RH SIDE	
NLG Service Panel: 5GC	6.67 m (21.88 ft)		0.50 m (1.64 ft)	TBD
NLG Service Panel: 8GH	6.67 m (21.88 ft)	On centerline		TBD

4. Technical Specifications

- A. Power Supply:
 - Two-phase, 115 V, 400 Hz
 - 28V DC.
- B. Electrical Connector for Servicing:
 - Bernier, 22-11-10-13 Connector.
- C. Pin Allocation:

Pin Identification	
A	28V DC
B	0V DC
D	115V AC
E	0V AC
G	PWR SPLY
H	INT LOCK

NOTE : The power cable should be extendable in order to guarantee fit and non-interference with nose gear nor tow vehicle during the pick-up and the towing process. The connector shall be secured against pull-out by means of straps against the nose gear.

****ON A/C A330-200F**

5. A/C External Power

NOTE : The mean height from ground in the below table may change according to the CG position and aircraft weight.

ACCESS	DISTANCE			MEAN HEIGHT FROM GROUND
	AFT OF NOSE	FROM AIRCRAFT CENTERLINE		
		LH SIDE	RH SIDE	
A/C External Power: Access Door 125EL	7.20 m (23.62 ft)	On centerline		2.29 m (7.51 ft)

NOTE : Distances are approximate.

6. Technical Specifications

- A. External Power Receptacles:
 - Two receptacles according to MS 90362-3 - 90 kVA.
- B. Power Supply:
 - Three-phase, 115 V, 400 Hz.
- C. Electrical Connectors for Servicing:
 - AC outlets: HUBBELL 5258



AIRCRAFT CHARACTERISTICS - AIRPORT AND MAINTENANCE PLANNING

- DC outlets: HUBBELL 7472.

****ON A/C A330-200 A330-300 A330-800 A330-900**

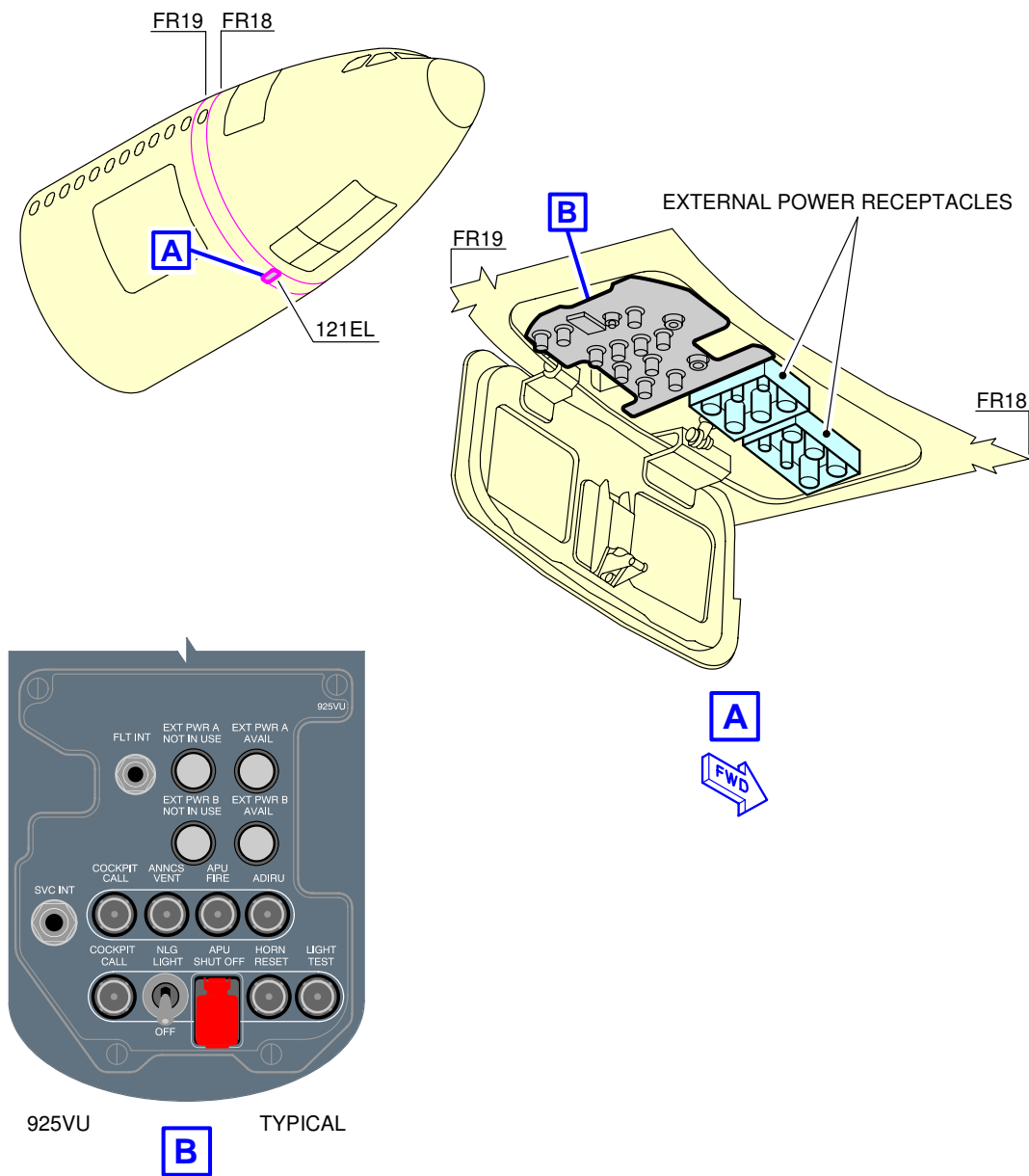

F_AC_050404_1_0050101_01_01

Ground Service Connections
 Electrical Service Panel
 FIGURE-5-4-4-991-005-A01

****ON A/C A330-200F**

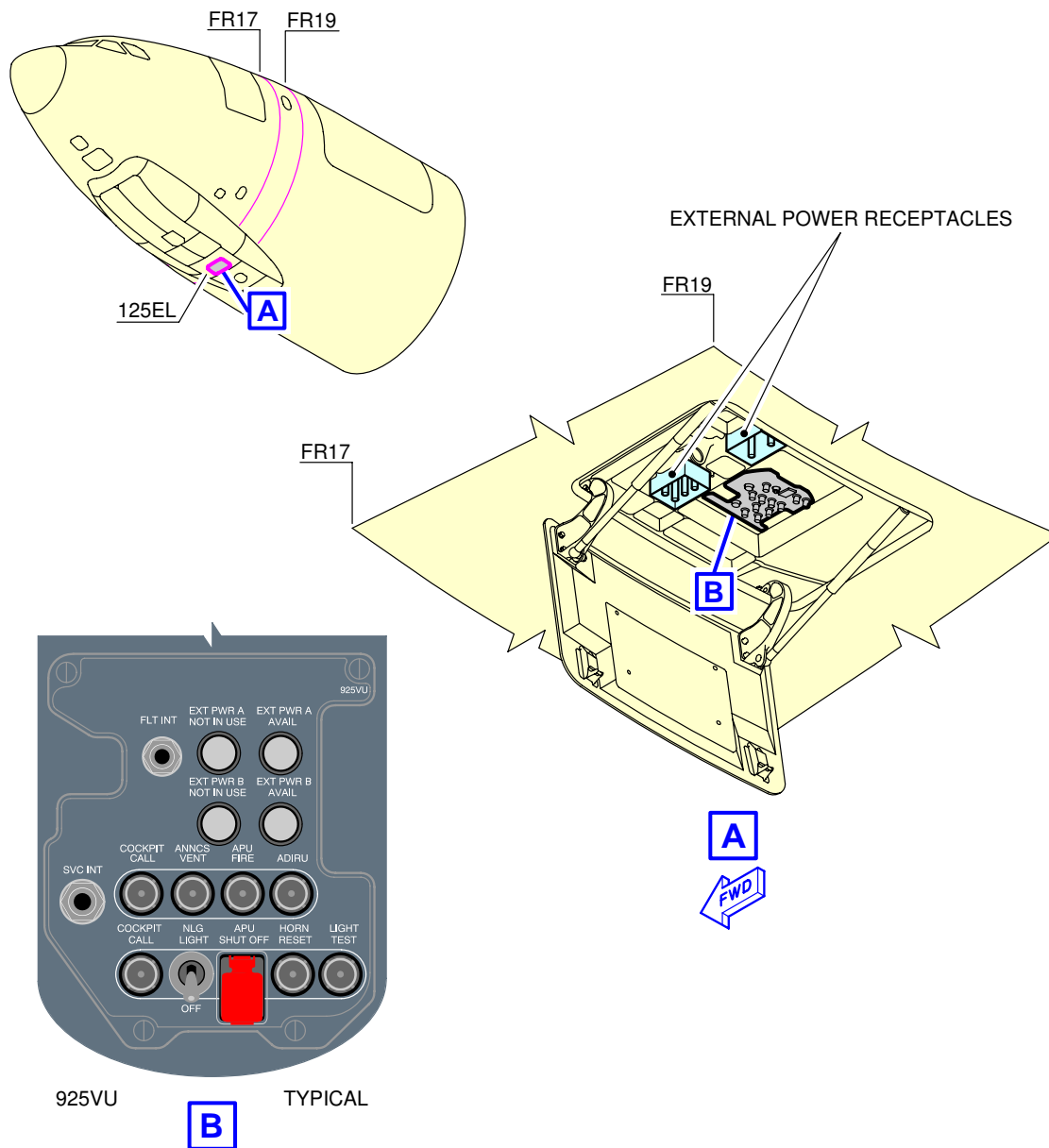

F_AC_050404_1_0010201_01_01

Ground Service Connections
Electrical Service Panel
FIGURE-5-4-4-991-001-B01

5-4-5 Oxygen System

****ON A/C A330-200 A330-200F A330-300 A330-800 A330-900**

Oxygen Servicing

****ON A/C A330-200 A330-300 A330-800 A330-900**

1. Oxygen Servicing

NOTE : The mean height from ground in the below table may change according to the CG position and aircraft weight.

ACCESS	DISTANCE			MEAN HEIGHT FROM GROUND
	AFT OF NOSE	FROM AIRCRAFT CENTERLINE		
		LH SIDE	RH SIDE	
Oxygen Replenishment (Option 1): Access Door 811	2.50 m (8.20 ft)		0.53 m (1.74 ft)	3.20 m (10.50 ft)
Oxygen Replenishment (Option 2): Access Door 811	2.50 m (8.20 ft)		0.68 m (2.23 ft)	3.20 m (10.50 ft)

- 0 – Basic: External charging in the avionic compartment
- 1 – Option
- 2 – Option.

Zero, one or two MIL-DTL 7891 standard service connections (external charging in the avionics compartment).

NOTE : Internal charging connection provided.

****ON A/C A330-200F**

2. Oxygen Servicing

NOTE : The mean height from ground in the below table may change according to the CG position and aircraft weight.

ACCESS	DISTANCE			MEAN HEIGHT FROM GROUND
	AFT OF NOSE	FROM AIRCRAFT CENTERLINE		
		LH SIDE	RH SIDE	
Oxygen Replenishment: Access Panel 132NW	11.26 m (36.94 ft)		2.50 m (8.20 ft)	4.20 m (13.78 ft)



AIRCRAFT CHARACTERISTICS - AIRPORT AND MAINTENANCE PLANNING

- Basic: External charging in the FWD cargo compartment.
One MIL-DTL 7891 standard service connection (external charging in the FWD cargo compartment).

NOTE : Internal charging connection provided.

**ON A/C A330-200 A330-300 A330-800 A330-900

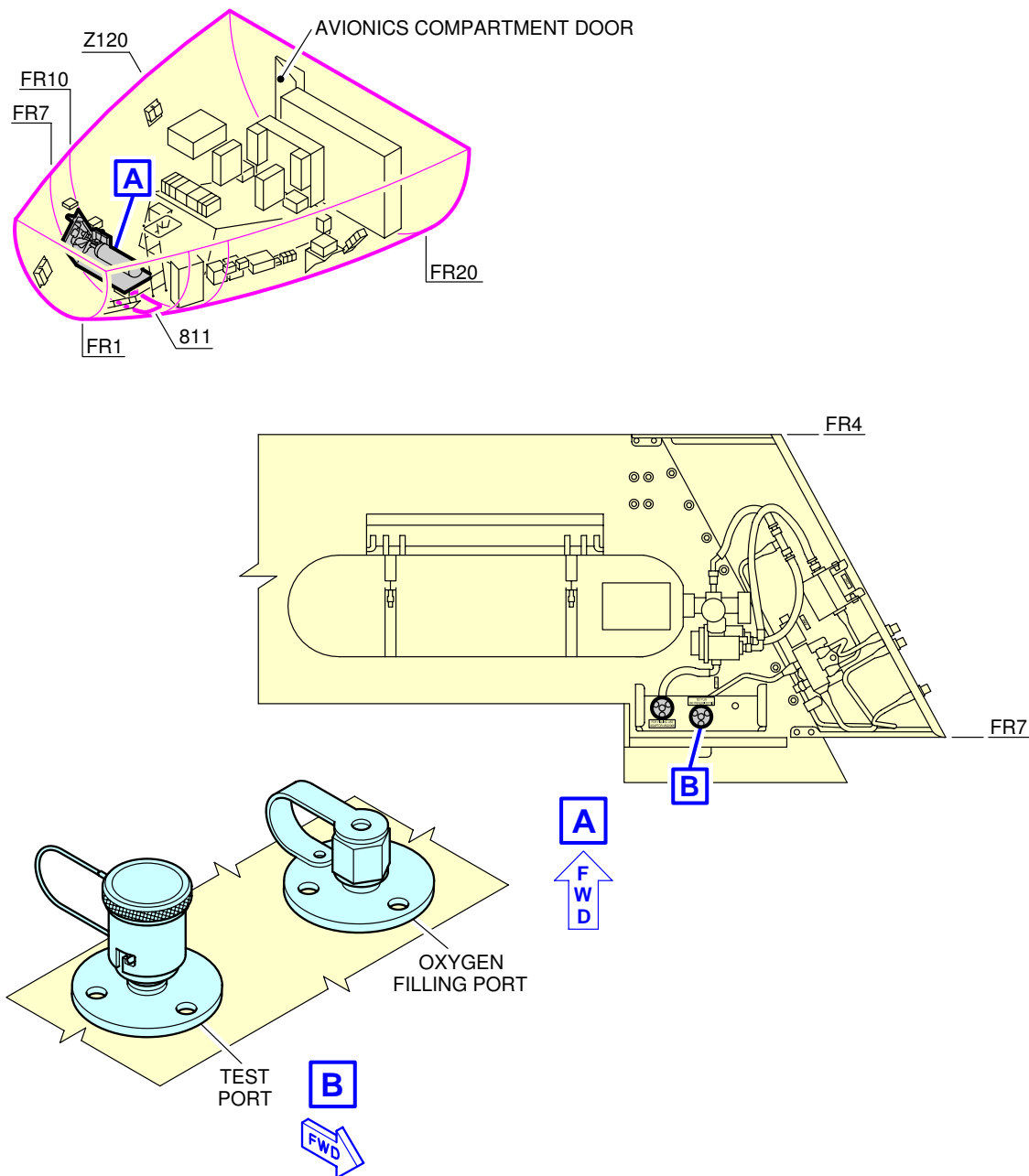

NOTE:

THE NUMBER OF OXYGEN CYLINDERS DEPENDS ON THE SYSTEM CONFIGURATION.

F_AC_050405_1_0010101_01_01

Ground Service Connections
Oxygen Servicing
FIGURE-5-4-5-991-001-A01

**ON A/C A330-200F

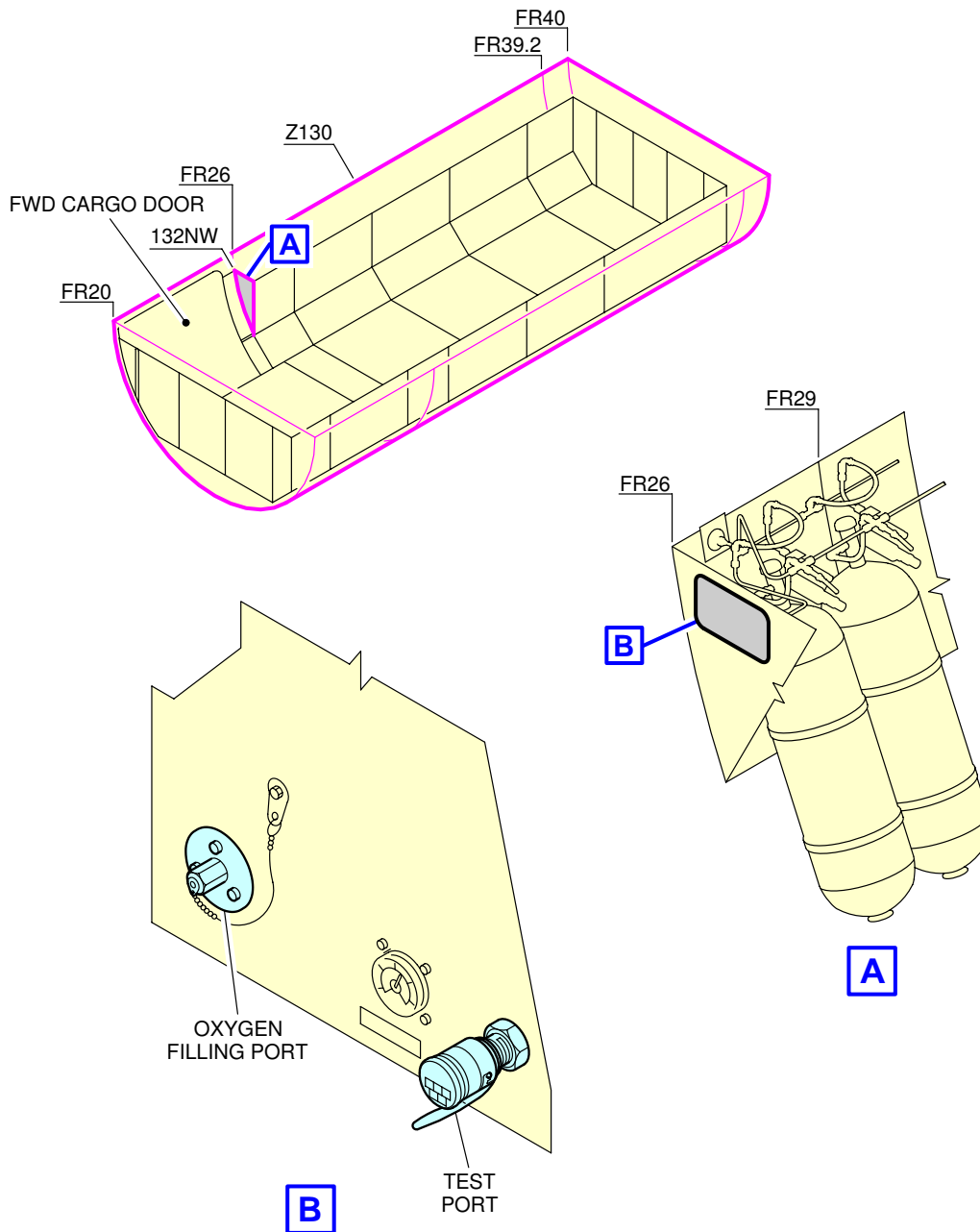

NOTE:
THE NUMBER OF OXYGEN CYLINDERS DEPENDS ON THE SYSTEM CONFIGURATION.

F_AC_050405_1_0020101_01_01

Ground Service Connections
Oxygen Servicing
FIGURE-5-4-5-991-002-A01

5-4-6 Fuel System

****ON A/C A330-200 A330-200F A330-300 A330-800 A330-900**

Fuel System

****ON A/C A330-200 A330-800**

1. Refuel/Defuel Control Panel

NOTE : The mean height from ground in the below table may change according to the CG position and aircraft weight.

ACCESS	DISTANCE			MEAN HEIGHT FROM GROUND
	AFT OF NOSE	FROM AIRCRAFT CENTERLINE		
		LH SIDE	RH SIDE	
Refuel/Defuel Control Panel: Access Door 198DB	31.1 m (102.03 ft)	-	0.8 m (2.62 ft)	1.9 m (6.23 ft)

A. Flow rate: 1580 l/min (417 US gal/min) per connection.

B. Maximum pressure: 50 psi (3.45 bar).

2. Refuel/Defuel Connectors

NOTE : The mean height from ground in the below table may change according to the CG position and aircraft weight.

ACCESS	DISTANCE			MEAN HEIGHT FROM GROUND
	AFT OF NOSE	FROM AIRCRAFT CENTERLINE		
		LH SIDE	RH SIDE	
Refuel/Defuel Control Panel: Access Door 522HB	26.8 m (87.93 ft)	12.6 m 41.34 ft	-	5 m (16.4 ft)
Refuel/Defuel Coupling, Right: Access Door 622HB	26.8 m (87.93 ft)	-	12.6 m (41.34 ft)	5 m (16.4 ft)
Overwing Gravity Refuel Cap	31.3 m (102.69 ft)	17.2 m (56.43 ft)	17.2 m (56.43 ft)	5.8 m (19.03 ft)

A. Four standard 2.5 in. ISO 45 connections.

B. Two service connections (gravity refuel).

3. Overpressure Protector and NACA Flame Arrestor

NOTE : The mean height from ground in the below table may change according to the CG position and aircraft weight.

ACCESS	DISTANCE			
	AFT OF NOSE	FROM AIRCRAFT CENTERLINE		MEAN HEIGHT FROM GROUND
		LH SIDE	RH SIDE	
Overpressure Protector (Wing) Access Panel 550EB (650EB)	36.3 m (119.09 ft)	27.17 m (89.14 ft)	27.17 m (89.14 ft)	5.75 m (18.86 ft)
NACA Flame Arrestor (Wing) Access Panel 550DB (650DB)	35.94 m (117.91 ft)	26.53 m (87.04 ft)	26.53 m (87.04 ft)	5.7 m (18.7 ft)
Overpressure Protector (Trim Tank) Access Panel 346AB	56.36 m (184.91 ft)	8 m (26.25 ft)	8 m (26.25 ft)	5.7 m (18.7 ft)
NACA Flame Arrestor (Trim Tank) Access Panel 346AB	56.36 (184.91 ft)	8 m (26.25 ft)	8 m (26.25 ft)	5.7 m (18.7 ft)

****ON A/C A330-300 A330-900**

4. Refuel/Defuel Control Panel

NOTE : The mean height from ground in the below table may change according to the CG position and aircraft weight.

ACCESS	DISTANCE			
	AFT OF NOSE	FROM AIRCRAFT CENTERLINE		MEAN HEIGHT FROM GROUND
		LH SIDE	RH SIDE	
Refuel/Defuel Control Panel: Access Door 198DB	34.3 m (112.53 ft)	-	0.8 m (2.62 ft)	1.9 m (6.23 ft)

- A. Flow rate: 1580 l/min (417 US gal/min) per connection.
- B. Maximum pressure: 50 psi (3.45 bar).

5. Refuel/Defuel Connectors

NOTE : The mean height from ground in the below table may change according to the CG position and aircraft weight.

ACCESS	DISTANCE			
	AFT OF NOSE	FROM AIRCRAFT CENTERLINE		MEAN HEIGHT FROM GROUND
		LH SIDE	RH SIDE	
Refuel/Defuel Coupling, Left (Optional): Access Door 522HB	30 m (98.43 ft)	12.6 m (41.34 ft)-	-	5 m (16.4 ft)
Refuel/Defuel Coupling, Right: Access Door 622HB	30 m (98.43 ft)	-	12.6 m (41.34 ft)	5 m (16.4 ft)
Overwing Gravity Refuel Cap	34.5 m (113.19 ft)	17.2 m (56.43 ft)	17.2 m (56.43 ft)	5.8 m (19.03 ft)

- A. Four standard 2.5 in. ISO 45 connections.
- B. Two service connections (gravity refuel).

6. Overpressure Protector and NACA Flame Arrestor

NOTE : The mean height from ground in the below table may change according to the CG position and aircraft weight.

ACCESS	DISTANCE			
	AFT OF NOSE	FROM AIRCRAFT CENTERLINE		MEAN HEIGHT FROM GROUND
		LH SIDE	RH SIDE	
Overpressure Protector (Wing) Access Panel 550EB (650EB)	39.48 m (129.53 ft)	27.17 m (89.14 ft)	27.17 m (89.14 ft)	5.75 m (18.86 ft)
NACA Flame Arrestor (Wing) Access Panel 550DB (650DB)	39.12 m (128.35 ft)	26.53 m (87.04 ft)	26.53 m (87.04 ft)	5.7 m (18.7 ft)
Overpressure Protector (Trim Tank) Access Panel 346AB	61.67 m 202.33 ft	8 m (26.25 ft)	8 m (26.25 ft)	5.7 m (18.7 ft)

ACCESS	DISTANCE			
	AFT OF NOSE	FROM AIRCRAFT CENTERLINE		MEAN HEIGHT FROM GROUND
		LH SIDE	RH SIDE	
NACA Flame Arrestor (Trim Tank) Access Panel 346AB	61.67 m (202.33 ft)	8 m (26.25 ft)	8 m (26.25 ft)	5.7 m (18.7 ft)

****ON A/C A330-200F**

7. Refuel/Defuel Control Panel

NOTE : The mean height from ground in the below table may change according to the CG position and aircraft weight.

ACCESS	DISTANCE			
	AFT OF NOSE	FROM AIRCRAFT CENTERLINE		MEAN HEIGHT FROM GROUND
		LH SIDE	RH SIDE	
Refuel/Defuel Control Panel: Access Door 198DB	31.1 m (102.03 ft)	-	0.8 m (2.62 ft)	1.9 m (6.23 ft)

A. Flow rate: 1580 l/min (417 US gal/min) per connection.

B. Maximum pressure: 50 psi (3.45 bar).

8. Refuel/Defuel Connectors

NOTE : The mean height from ground in the below table may change according to the CG position and aircraft weight.

ACCESS	DISTANCE			
	AFT OF NOSE	FROM AIRCRAFT CENTERLINE		MEAN HEIGHT FROM GROUND
		LH SIDE	RH SIDE	
Refuel/Defuel Coupling, Left (Optional): Access Door 522HB	26.8 m (87.93 ft)	12.6 m (41.34 ft)	-	5.1 m (16.73 ft)
Refuel/Defuel Coupling, Right: Access Door 622HB	26.8 m (87.93 ft)	-	12.6 m (41.34 ft)	5.1 m (16.73 ft)
Overwing Gravity Refuel Cap	31.3 m (102.69 ft)	17.2 m (56.43 ft)	17.2 m (56.43 ft)	6.1 m (20.01 ft)

- A. Four standard 2.5 in. ISO 45 connections.
 - B. Two service connections (gravity refuel).
9. Overpressure Protector and NACA Flame Arrestor

NOTE : The mean height from ground in the below table may change according to the CG position and aircraft weight.

ACCESS	DISTANCE			
	AFT OF NOSE	FROM AIRCRAFT CENTERLINE		MEAN HEIGHT FROM GROUND
		LH SIDE	RH SIDE	
Overpressure Protector (Wing) Access Panel 550EB (650EB)	36.3 m (119.09 ft)	27.17 m (89.14 ft)	27.17 m (89.14 ft)	5.75 m (18.86 ft)
NACA Flame Arrestor (Wing) Access Panel 550DB (650DB)	35.94 m (117.91 ft)	26.53 m (87.04 ft)	26.53 m (87.04 ft)	5.7 m (18.7 ft)
Overpressure Protector (Trim Tank) Access Panel 346AB	56.36 m (184.91 ft)	8 m (26.25 ft)	8 m (26.25 ft)	5.7 m (18.7 ft)
NACA Flame Arrestor (Trim Tank) Access Panel 346AB	56.36 (184.91 ft)	8 m (26.25 ft)	8 m (26.25 ft)	5.7 m (18.7 ft)

**ON A/C A330-200 A330-200F A330-300 A330-800 A330-900

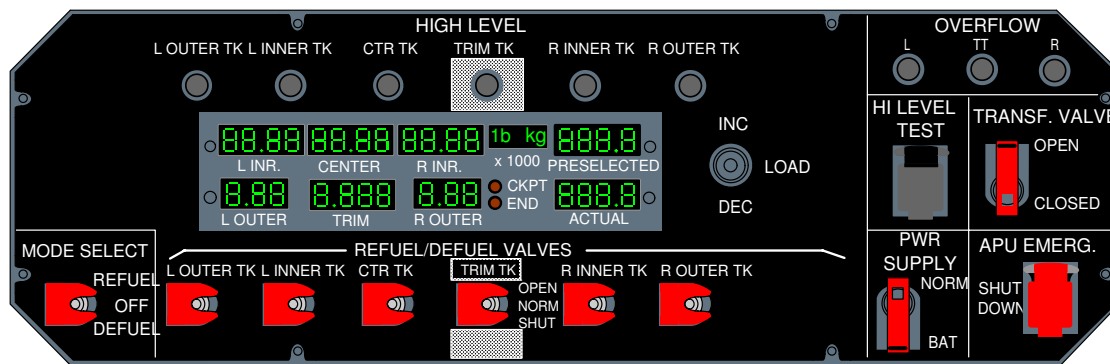
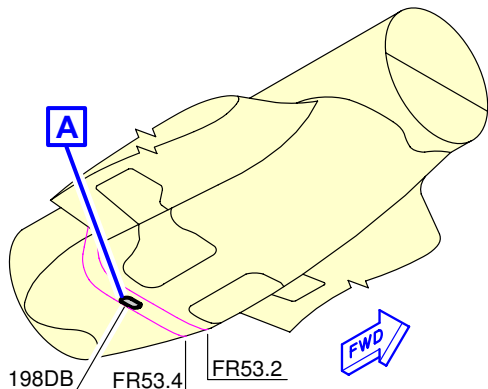

A

F_AC_050406_1_0120101_01_01

Ground Service Connections
 Refuel/Defuel Control Panel
 FIGURE-5-4-6-991-012-A01

**ON A/C A330-200 A330-200F A330-300 A330-800 A330-900

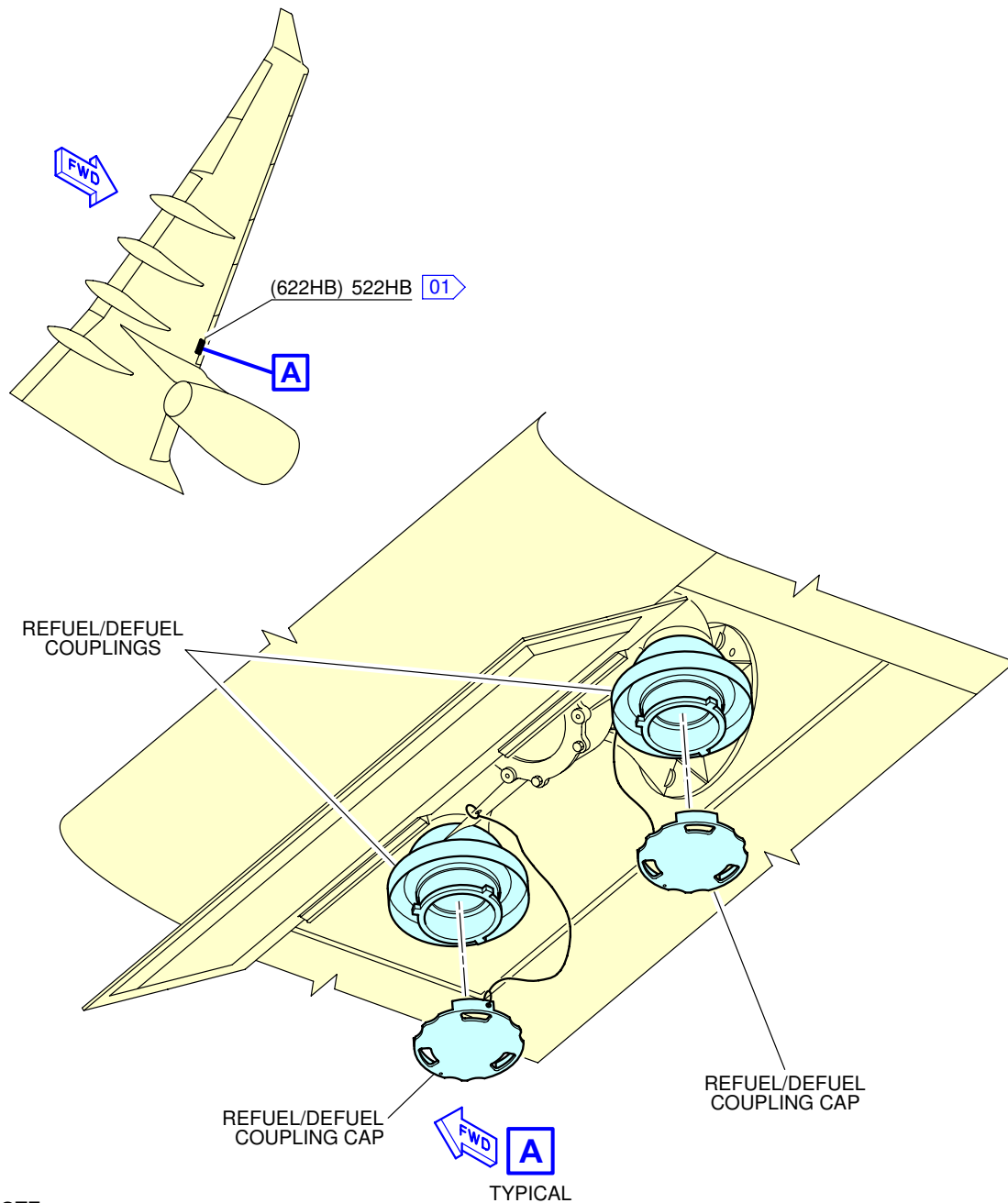

NOTE:

01 LEFT ACCESS DOOR 522HB (OPTIONAL ON A/C A330-200F, A330-300, A330-800 AND A300-900).

F_AC_050406_1_0130101_01_04

Ground Service Connections
Refuel/Defuel Coupling
FIGURE-5-4-6-991-013-A01

**ON A/C A330-200 A330-200F A330-300 A330-800 A330-900

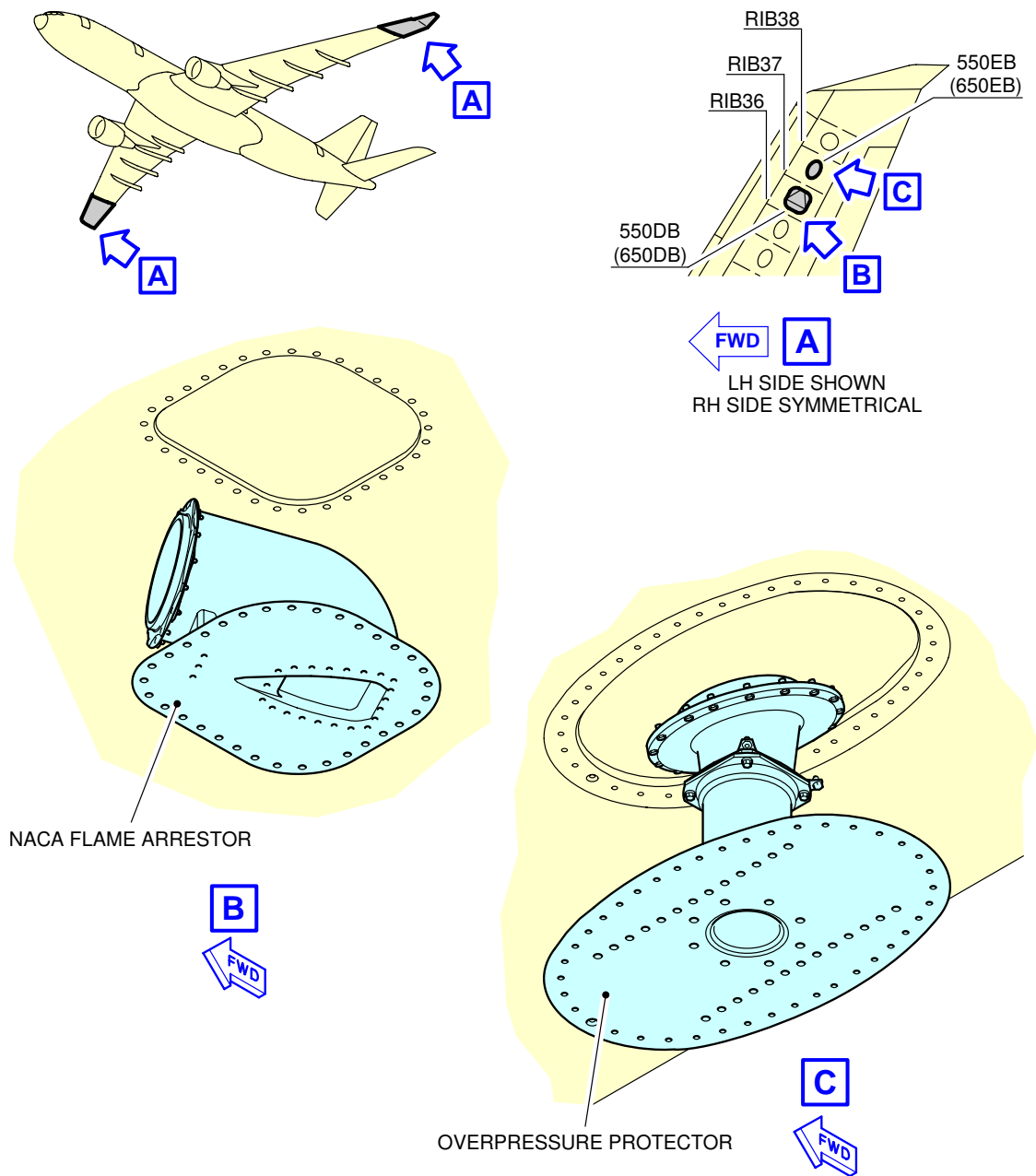

F_AC_050406_1_0020101_01_00

Ground Service Connections
Overpressure Protector and NACA Flame Arrestor - Wing
FIGURE-5-4-6-991-002-A01

**ON A/C A330-200 A330-200F A330-300 A330-800 A330-900

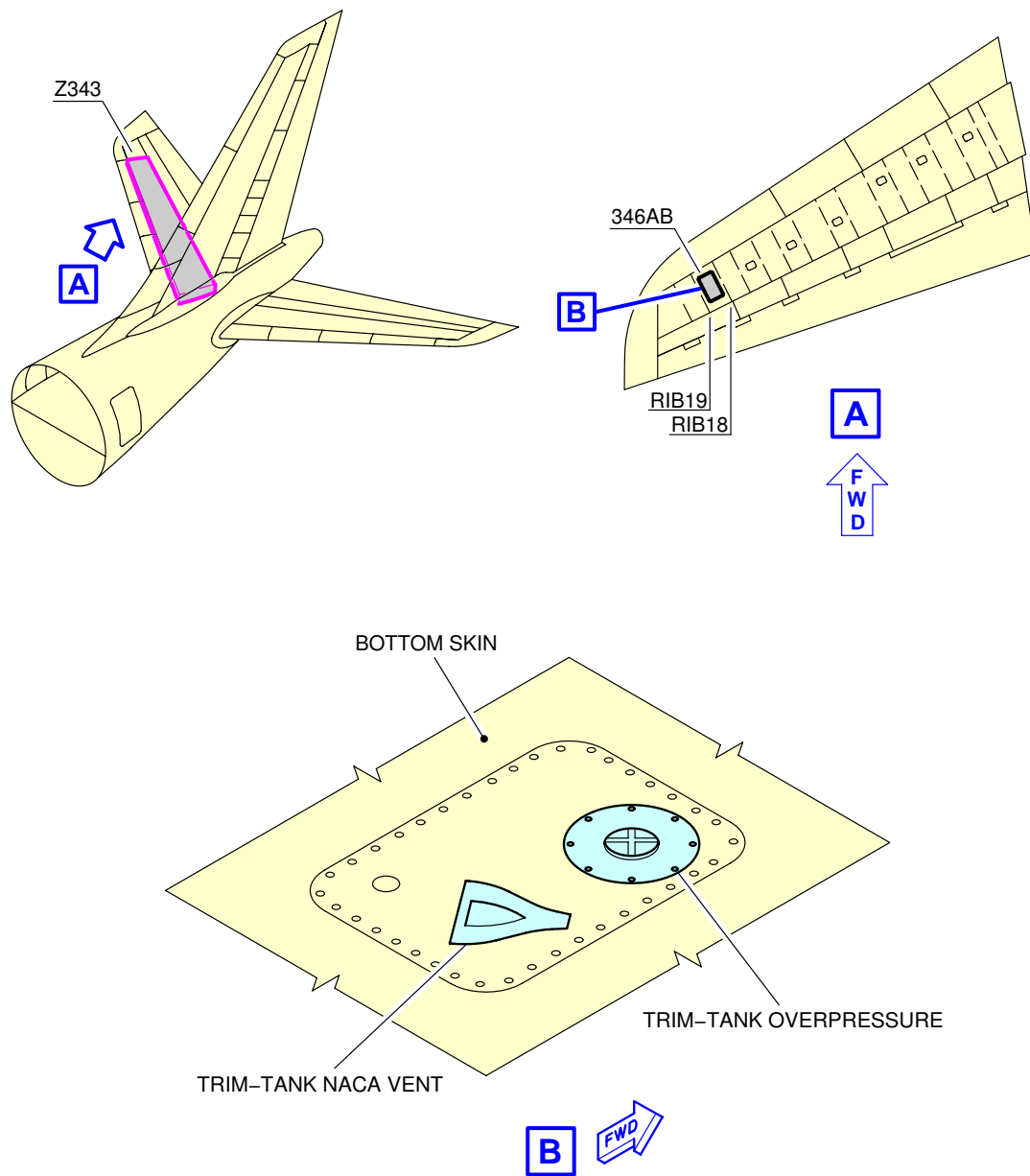

F_AC_050406_1_0060101_01_01

Ground Service Connections
Overpressure Protector and NACA Flame Arrestor - Trim Tank
FIGURE-5-4-6-991-006-A01

5-4-7 Pneumatic System

****ON A/C A330-200 A330-200F A330-300 A330-800 A330-900**

Pneumatic Servicing

****ON A/C A330-300 A330-900**

1. High Pressure Air Connection

NOTE : The mean height from ground in the below table may change according to the CG position and aircraft weight.

ACCESS	DISTANCE			
	AFT OF NOSE	FROM AIRCRAFT CENTERLINE		MEAN HEIGHT FROM GROUND
		LH SIDE	RH SIDE	
HP Connectors: Access Door 193CB	23.9 m (78.41 ft)	0.84 m (2.76 ft)		1.79 m (5.87 ft)
	24.25 m (79.56 ft)	0.84 m (2.76 ft)		1.79 m (5.87 ft)

- A. Connectors:
- Two standard 3 in. ISO 2026 connections.

2. Low Pressure Air Connection

NOTE : The mean height from ground in the below table may change according to the CG position and aircraft weight.

ACCESS	DISTANCE			
	AFT OF NOSE	FROM AIRCRAFT CENTERLINE		MEAN HEIGHT FROM GROUND
		LH SIDE	RH SIDE	
LP Connectors: Access Door 191EB	22.48 m (73.75 ft)	0.31 m (1.02 ft)		1.86 m (6.10 ft)
	22.48 m (73.75 ft)	0.76 m (2.49 ft)		1.86 m (6.10 ft)

- A. Connectors:
- Two standard 8 in. SAE AS4262 connections.

****ON A/C A330-200 A330-200F A330-800**

3. High Pressure Air Connection

NOTE : The mean height from ground in the below table may change according to the CG position and aircraft weight.

ACCESS	DISTANCE			
	AFT OF NOSE	FROM AIRCRAFT CENTERLINE		MEAN HEIGHT FROM GROUND
		LH SIDE	RH SIDE	
HP Connectors: Access Door 193CB	20.72 m (67.98 ft)	0.84 m (2.76 ft)		1.96 m (6.43 ft)
	21.08 m (69.16 ft)	0.84 m (2.76 ft)		1.94 m (6.36 ft)

- A. Connectors:
 - Two standard 3 in. ISO 2026 connections.

4. Low Pressure Air Connection

NOTE : The mean height from ground in the below table may change according to the CG position and aircraft weight.

ACCESS	DISTANCE			
	AFT OF NOSE	FROM AIRCRAFT CENTERLINE		MEAN HEIGHT FROM GROUND
		LH SIDE	RH SIDE	
LP Connectors: Access Door 191EB	19.29 m (63.29 ft)	0.31 m (1.02 ft)		2.08 m (6.82 ft)
	19.29 m (63.29 ft)	0.76 m (2.49 ft)		2.11 m (6.92 ft)

- A. Connectors:
 - Two standard 8 in. SAE AS4262 connections.

**ON A/C A330-200 A330-200F A330-300 A330-800 A330-900

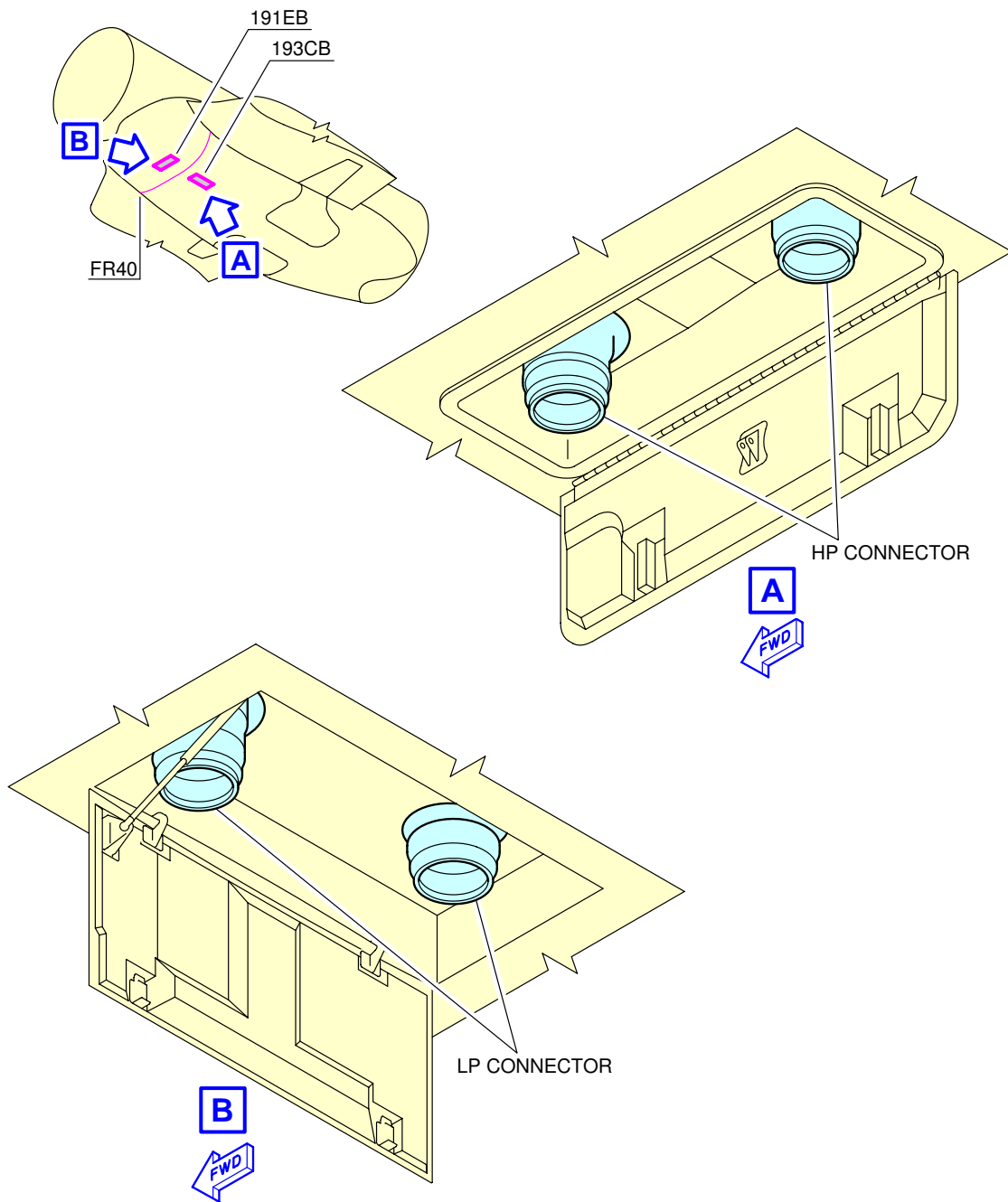

F_AC_050407_1_0010101_01_00

Ground Service Connections
LP and HP Ground Connectors
FIGURE-5-4-7-991-001-A01

5-4-8 Oil System

****ON A/C A330-200 A330-200F A330-300**

Oil Servicing

1. PW 4000 Series Engine

A. Engine Oil Replenishment:

One gravity filling cap and one pressure filling connection per engine.

NOTE : The mean height from ground in the below table may change according to the CG position and aircraft weight.

ACCESS	DISTANCE			MEAN HEIGHT FROM GROUND
	AFT OF NOSE	FROM AIRCRAFT CENTERLINE		
		LH SIDE	RH SIDE	
Engine 1: Access Door: 417AL (418AR)	25.70 m (84.32 ft)	10.60 m (34.78 ft)		2.23 m (7.32 ft)
Engine 2: Access Door: 427AL (428AR)	25.70 m (84.32 ft)		8.07 m (26.48 ft)	2.23 m (7.32 ft)

(1) Tank capacity:

- Full level: 30.28 l (8.00 US gal).
- Usable: 21.77 l (5.75 US gal).

B. IDG Oil Replenishment:

One pressure filling connection per engine.

NOTE : The mean height from ground in the below table may change according to the CG position and aircraft weight.

ACCESS	DISTANCE			MEAN HEIGHT FROM GROUND
	AFT OF NOSE	FROM AIRCRAFT CENTERLINE		
		LH SIDE	RH SIDE	
Engine 1: Access Door: 417EL	26.16 m (85.83 ft)	10.07 m (33.04 ft)		1.50 m (4.92 ft)

ACCESS	DISTANCE			
	AFT OF NOSE	FROM AIRCRAFT CENTERLINE		MEAN HEIGHT FROM GROUND
		LH SIDE	RH SIDE	
Engine 2: Access Door: 427EL	26.16 m (85.83 ft)		8.66 m (28.41 ft)	1.50 m (4.92 ft)

- Max delivery pressure required: 2.76 bar (40 psi).
- Max oil capacity of the IDG: 4.10 l (1.08 US gal).

C. Starter Oil Replenishment:

One gravity filling and one pressure filling connection per engine.

NOTE : The mean height from ground in the below table may change according to the CG position and aircraft weight.

ACCESS	DISTANCE			
	AFT OF NOSE	FROM AIRCRAFT CENTERLINE		MEAN HEIGHT FROM GROUND
		LH SIDE	RH SIDE	
Engine 1: Access Door: 417AL (418AR)	26.16 m (85.83 ft)	10.07 m (33.04 ft)		1.50 m (4.92 ft)
Engine 2: Access Door: 427AL (428AR)	26.16 m (85.83 ft)		8.66 m (28.41 ft)	1.50 m (4.92 ft)

- Max oil capacity of the Starter: 0.30 l (0.08 US gal).

2. RR Trent 700 Series Engine

A. Engine Oil Replenishment:

One gravity filling cap.

One ozone self sealing pressure fill and overfill connector per engine.

NOTE : The mean height from ground in the below table may change according to the CG position and aircraft weight.

ACCESS	DISTANCE			MEAN HEIGHT FROM GROUND
	AFT OF NOSE	FROM AIRCRAFT CENTERLINE		
		LH SIDE	RH SIDE	
Engine 1: Access Door: 416CR	23.90 m (78.41 ft)	7.92 m (25.98 ft)		2.05 m (6.73 ft)
Engine 2: Access Door: 426CR	23.90 m (78.41 ft)		10.82 m (35.50 ft)	2.05 m (6.73 ft)

- (1) Tank capacity:
 - Full level: 23.30 l (6.16 US gal).
 - Usable: 22.71 l (6.00 US gal).

- B. IDG Oil Replenishment:
One ozone self sealing pressure fill and overfill connector per engine.

NOTE : The mean height from ground in the below table may change according to the CG position and aircraft weight.

ACCESS	DISTANCE			MEAN HEIGHT FROM GROUND
	AFT OF NOSE	FROM AIRCRAFT CENTERLINE		
		LH SIDE	RH SIDE	
Engine 1: Access Door: 415CL	24.38 m (79.99 ft)	9.65 m (31.66 ft)		0.80 m (2.62 ft)
Engine 2: Access Door: 425CL	24.38 m (79.99 ft)		9.09 m (29.82 ft)	0.80 m (2.62 ft)

- Max delivery pressure required: 2.76 bar (40 psi).
- Max oil capacity of the IDG: 5.50 l (1.45 US gal).

- C. Starter Oil Replenishment:
One filling connection per engine.

NOTE : The mean height from ground in the below table may change according to the CG position and aircraft weight.

ACCESS	DISTANCE			
	AFT OF NOSE	FROM AIRCRAFT CENTERLINE		MEAN HEIGHT FROM GROUND
		LH SIDE	RH SIDE	
Engine 1: Access Door: 415AL (416AR)	24.38 m (79.99 ft)	9.65 m (31.66 ft)		0.80 m (2.62 ft)
Engine 2: Access Door: 425AL (426AR)	24.38 m (79.99 ft)		9.09 m (29.82 ft)	0.80 m (2.62 ft)

- Max oil capacity of the Starter: 0.50 l (0.13 US gal).

****ON A/C A330-200 A330-300**

3. GE CF6-80E1 Series Engine

A. Engine Oil Replenishment:

One gravity filling cap and one pressure filling connection per engine.

NOTE : The mean height from ground in the below table may change according to the CG position and aircraft weight.

ACCESS	DISTANCE			
	AFT OF NOSE	FROM AIRCRAFT CENTERLINE		MEAN HEIGHT FROM GROUND
		LH SIDE	RH SIDE	
Engine 1: Access Door: 416BR	24.93 m (81.79 ft)	10.00 m (32.81 ft)		1.71 m (5.61 ft)
Engine 2: Access Door: 426BR	24.93 m (81.79 ft)		8.73 m (28.64 ft)	1.71 m (5.61 ft)

(1) Tank capacity:

- Full level: 24.57 l (6.49 US gal).
- Usable: 23.05 l (6.09 US gal).

B. IDG Oil Replenishment:

One pressure filling connection per engine.

NOTE : The mean height from ground in the below table may change according to the CG position and aircraft weight.

ACCESS	DISTANCE			
	AFT OF NOSE	FROM AIRCRAFT CENTERLINE		MEAN HEIGHT FROM GROUND
		LH SIDE	RH SIDE	
Engine 1: Access Door: 414BL	23.03 m (75.56 ft)	7.96 m (26.12 ft)		2.35 m (7.71 ft)
Engine 2: Access Door: 424BL	23.03 m (75.56 ft)		10.77 m (35.33 ft)	2.35 m (7.71 ft)

- Max delivery pressure required: 2.76 bar (40 psi).
- Max oil capacity of the IDG: 5.50 l (1.45 US gal).

C. Starter Oil Replenishment:
One gravity filling and one pressure filling connection per engine.

NOTE : The mean height from ground in the below table may change according to the CG position and aircraft weight.

ACCESS	DISTANCE			
	AFT OF NOSE	FROM AIRCRAFT CENTERLINE		MEAN HEIGHT FROM GROUND
		LH SIDE	RH SIDE	
Engine 1: Access Door: 417AL (418AR)	23.03 m (75.56 ft)	7.96 m (26.12 ft)		2.35 m (7.71 ft)
Engine 2: Access Door: 427AL (428AR)	23.03 m (75.56 ft)		10.77 m (35.33 ft)	2.35 m (7.71 ft)

- Max oil capacity of the Starter: 0.80 l (0.21 US gal).

**ON A/C A330-200 A330-200F A330-300

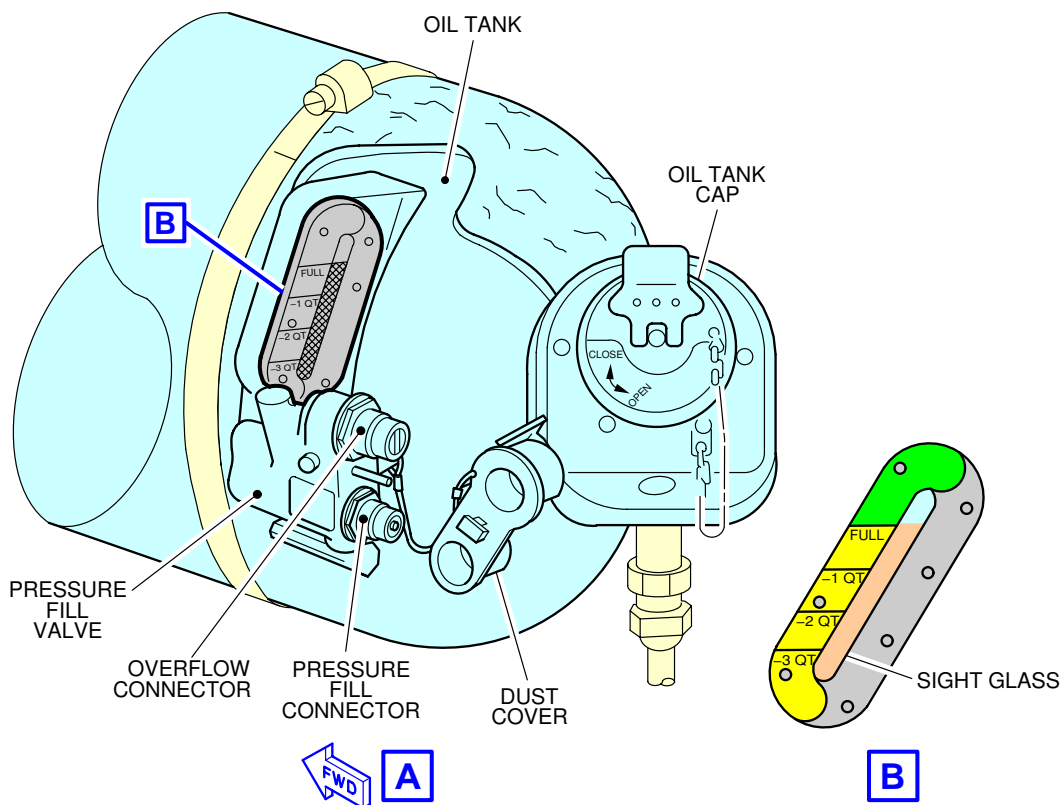
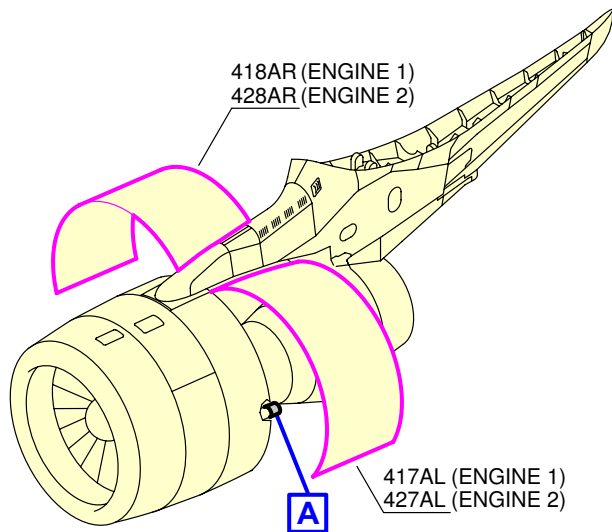

F_AC_050408_1_0110101_01_00

Ground Service Connections
Engine Oil Tank - PW 4000 Series Engine
FIGURE-5-4-8-991-011-A01

**ON A/C A330-200 A330-200F A330-300

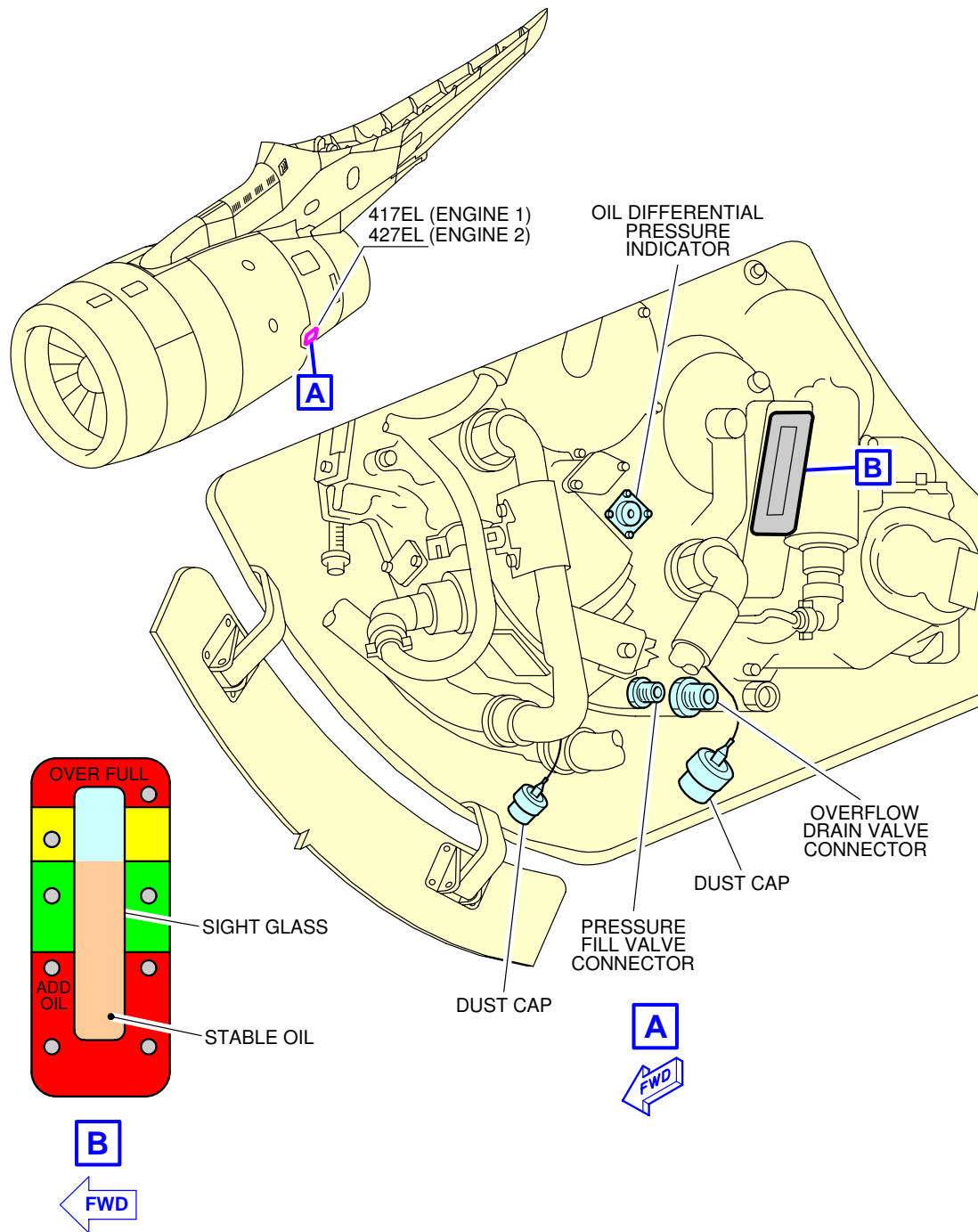

F_AC_050408_1_0120101_01_00

Ground Service Connections
IDG Oil Tank - PW 4000 Series Engine
FIGURE-5-4-8-991-012-A01

**ON A/C A330-200 A330-200F A330-300

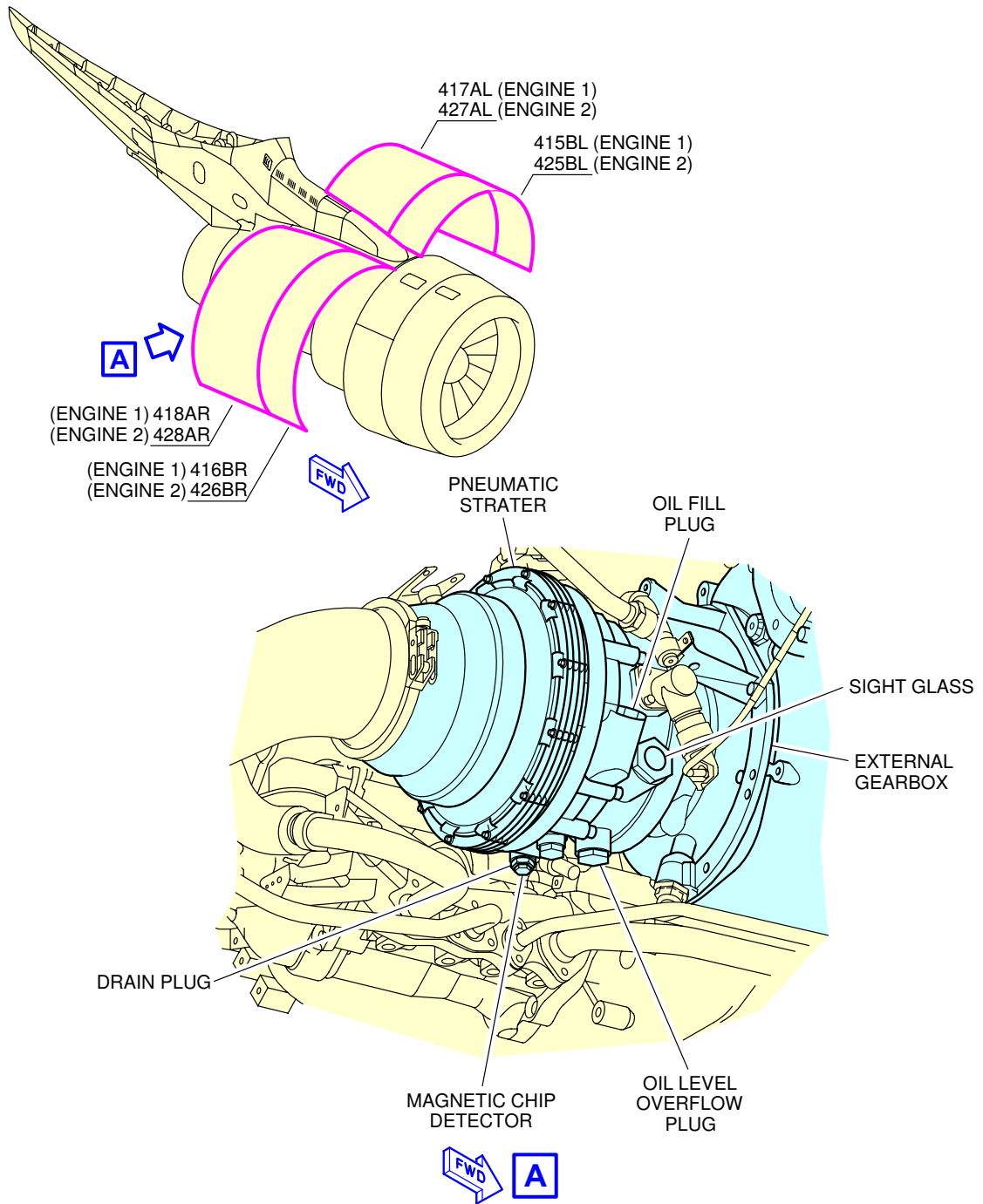

F_AC_050408_1_0240101_01_00

Ground Service Connections
Starter Oil Tank - PW 4000 Series Engine
FIGURE-5-4-8-991-024-A01

**ON A/C A330-200 A330-200F A330-300

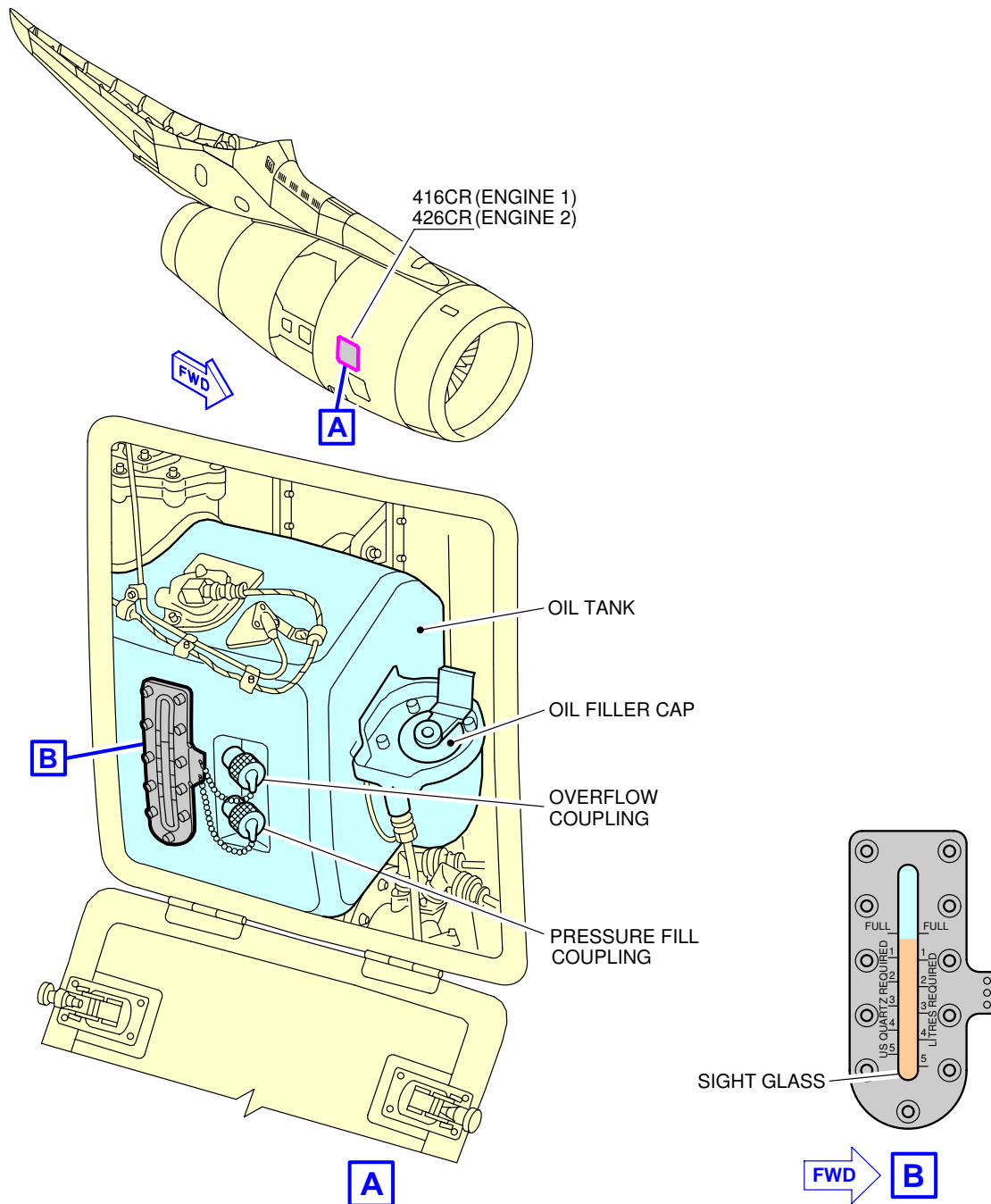

F_AC_050408_1_0130101_01_00

Ground Service Connections
Engine Oil Tank - RR Trent 700 Series Engine
FIGURE-5-4-8-991-013-A01

**ON A/C A330-200 A330-200F A330-300

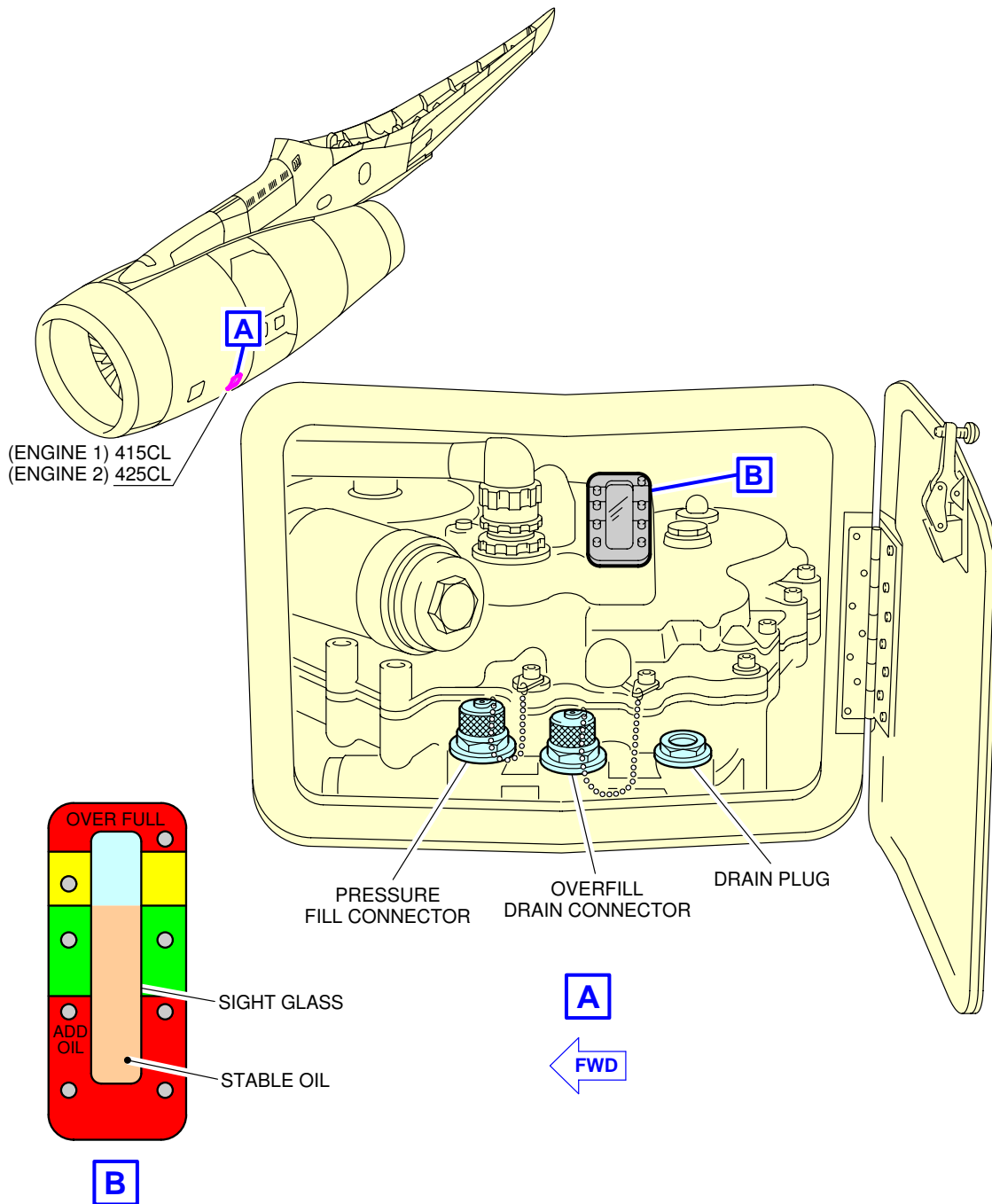

F_AC_050408_1_0140101_01_00

Ground Service Connections
IDG Oil Tank - RR Trent 700 Series Engine
FIGURE-5-4-8-991-014-A01

**ON A/C A330-200 A330-200F A330-300

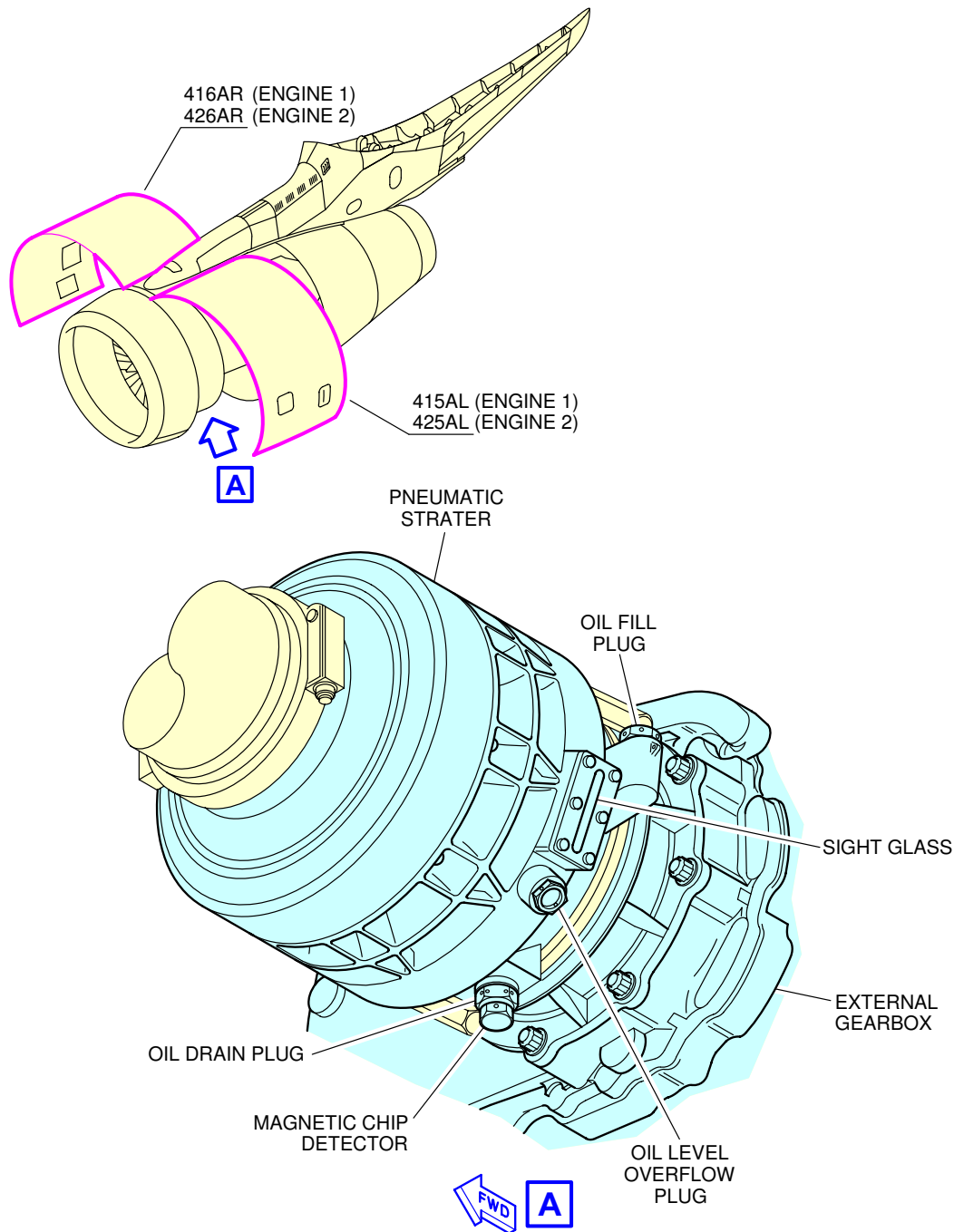

F_AC_050408_1_0250101_01_00

Ground Service Connections
Starter Oil Tank - RR Trent 700 Series Engine
FIGURE-5-4-8-991-025-A01

**ON A/C A330-200 A330-300

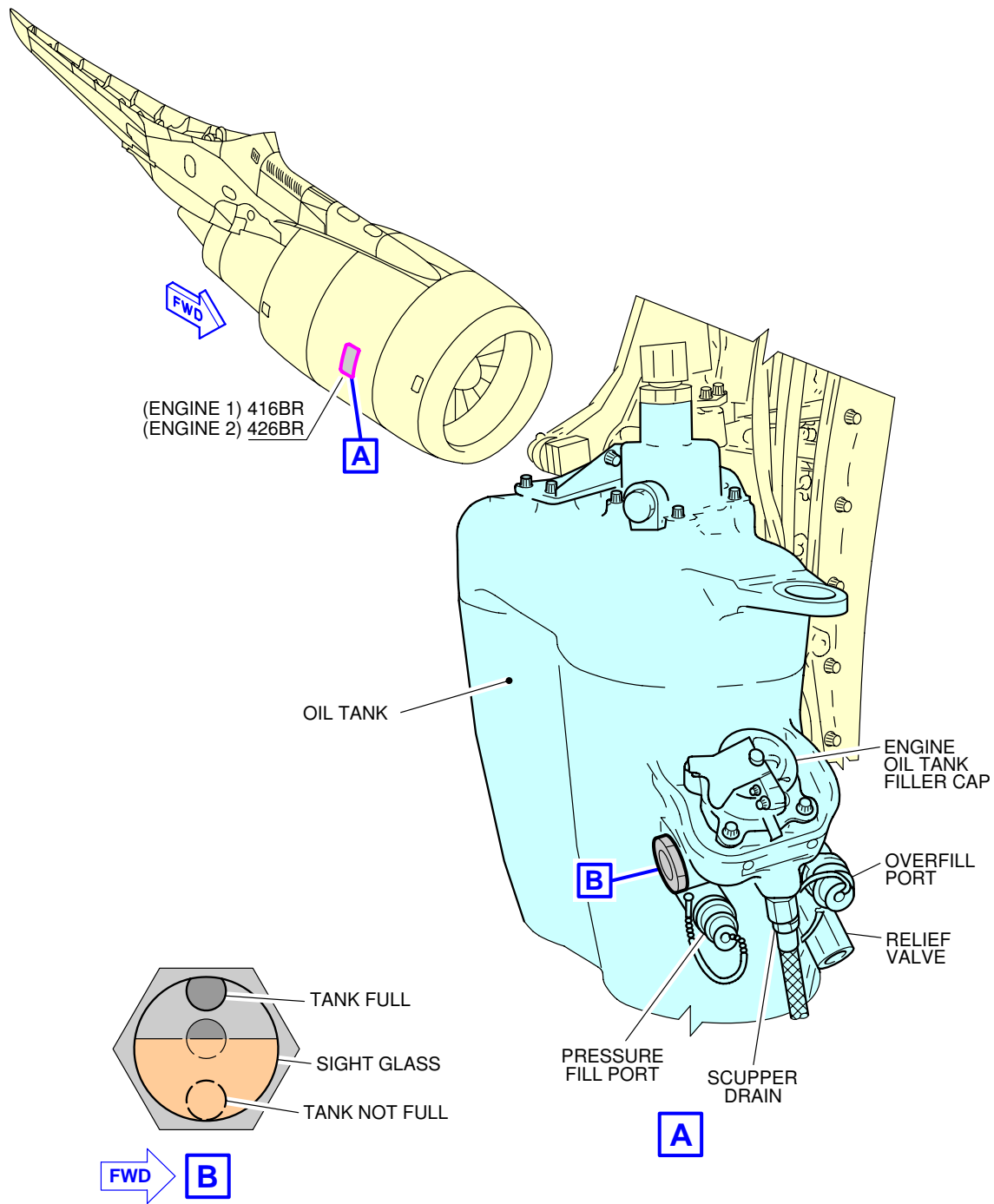

F_AC_050408_1_0150101_01_00

Ground Service Connections
Engine Oil Tank - GE CF6-80E1 Series Engine
FIGURE-5-4-8-991-015-A01

**ON A/C A330-200 A330-300

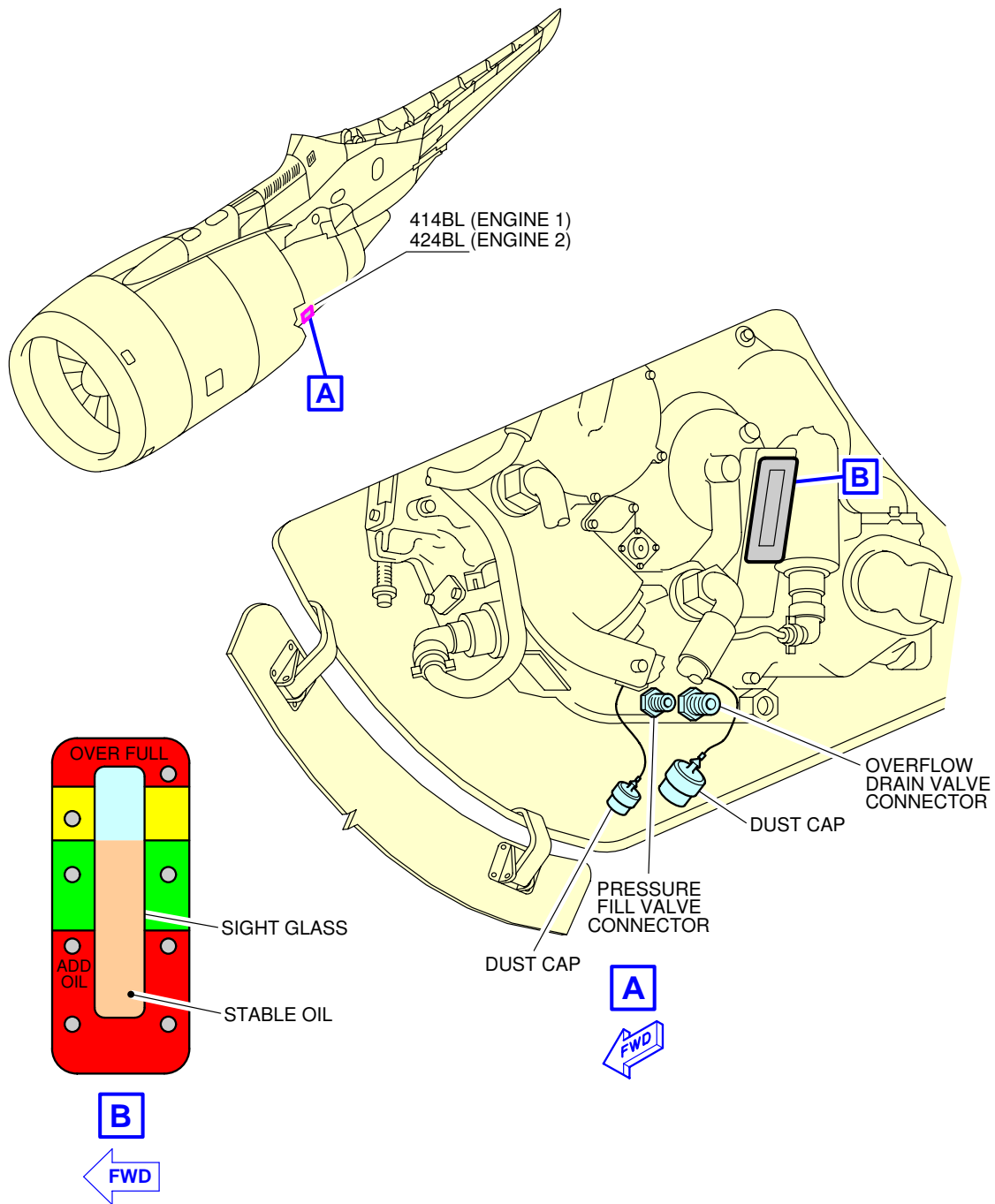

F_AC_050408_1_0160101_01_00

Ground Service Connections
IDG Oil Tank - GE CF6-80E1 Series Engine
FIGURE-5-4-8-991-016-A01

**ON A/C A330-200 A330-300

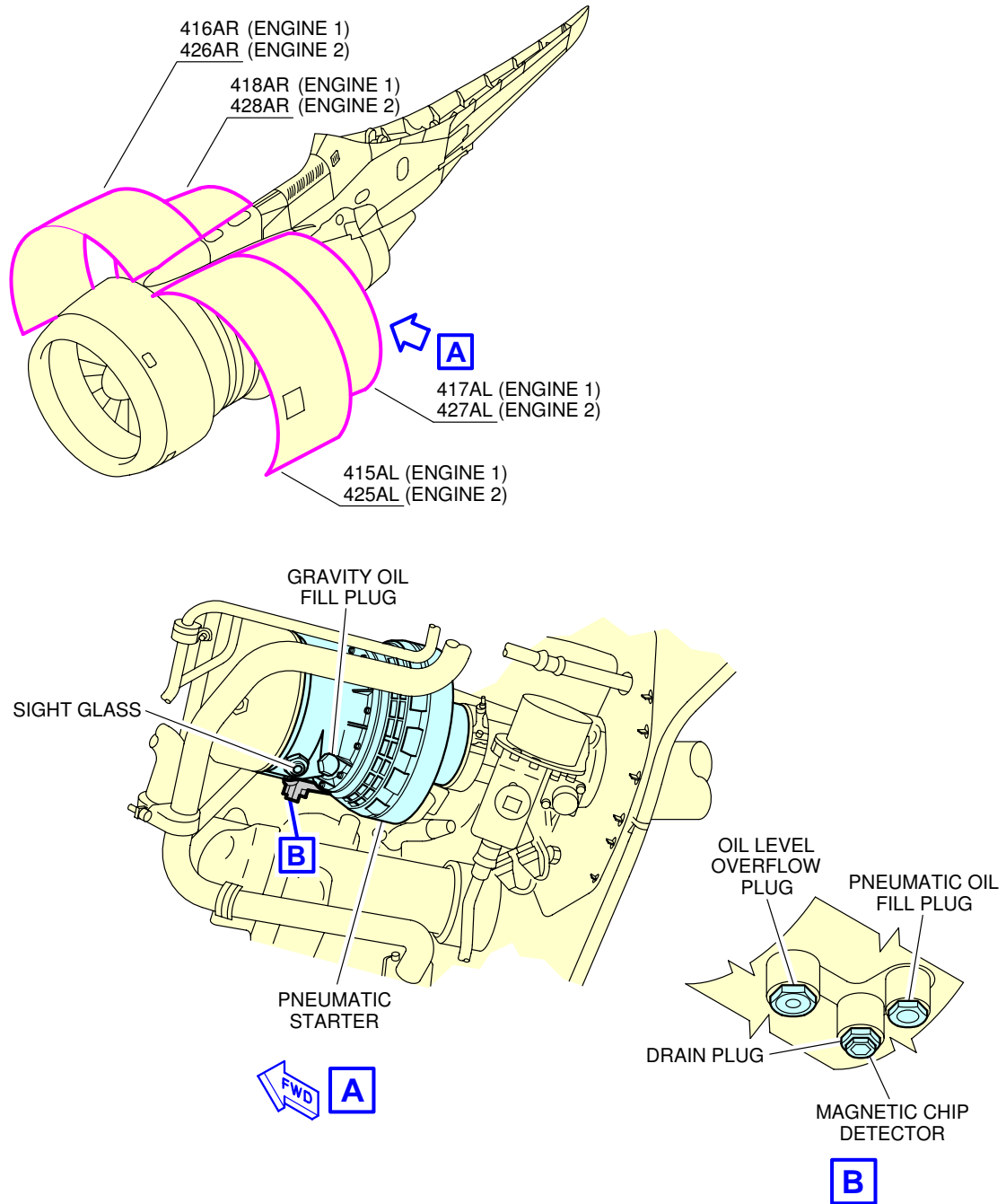

F_AC_050408_1_0260101_01_00

Ground Service Connections
Starter Oil Tank - GE CF6-80E1 Series Engine
FIGURE-5-4-8-991-026-A01

****ON A/C A330-200 A330-200F A330-300 A330-800 A330-900**

APU Oil Servicing

****ON A/C A330-300 A330-900**

1. APU Oil Servicing:
APU oil gravity filling cap.

NOTE : The mean height from ground in the below table may change according to the CG position and aircraft weight.

ACCESS	DISTANCE			MEAN HEIGHT FROM GROUND
	AFT OF NOSE	FROM AIRCRAFT CENTERLINE		
		LH SIDE	RH SIDE	
APU Oil Replenishment: Access Doors: 316AR, 315AL	60.3 m (197.83 ft)	0.4 m (1.31 ft)		8 m (26.25 ft)

- A. Tank capacity (usable):
 - APU Type: 331-350: 7.3 l (1.93 US gal).

****ON A/C A330-200 A330-200F A330-800**

2. APU Oil Servicing:
APU oil gravity filling cap.

NOTE : The mean height from ground in the below table may change according to the CG position and aircraft weight.

ACCESS	DISTANCE			MEAN HEIGHT FROM GROUND
	AFT OF NOSE	FROM AIRCRAFT CENTERLINE		
		LH SIDE	RH SIDE	
APU Oil Replenishment: Access Doors: 316AR, 315AL	55 m (180.45 ft)	0.4 m (1.31 ft)		8 m (26.25 ft)

- A. Tank capacity (usable):
 - APU Type: 331-350: 7.3 l (1.93 US gal).

**ON A/C A330-200 A330-200F A330-300 A330-800 A330-900

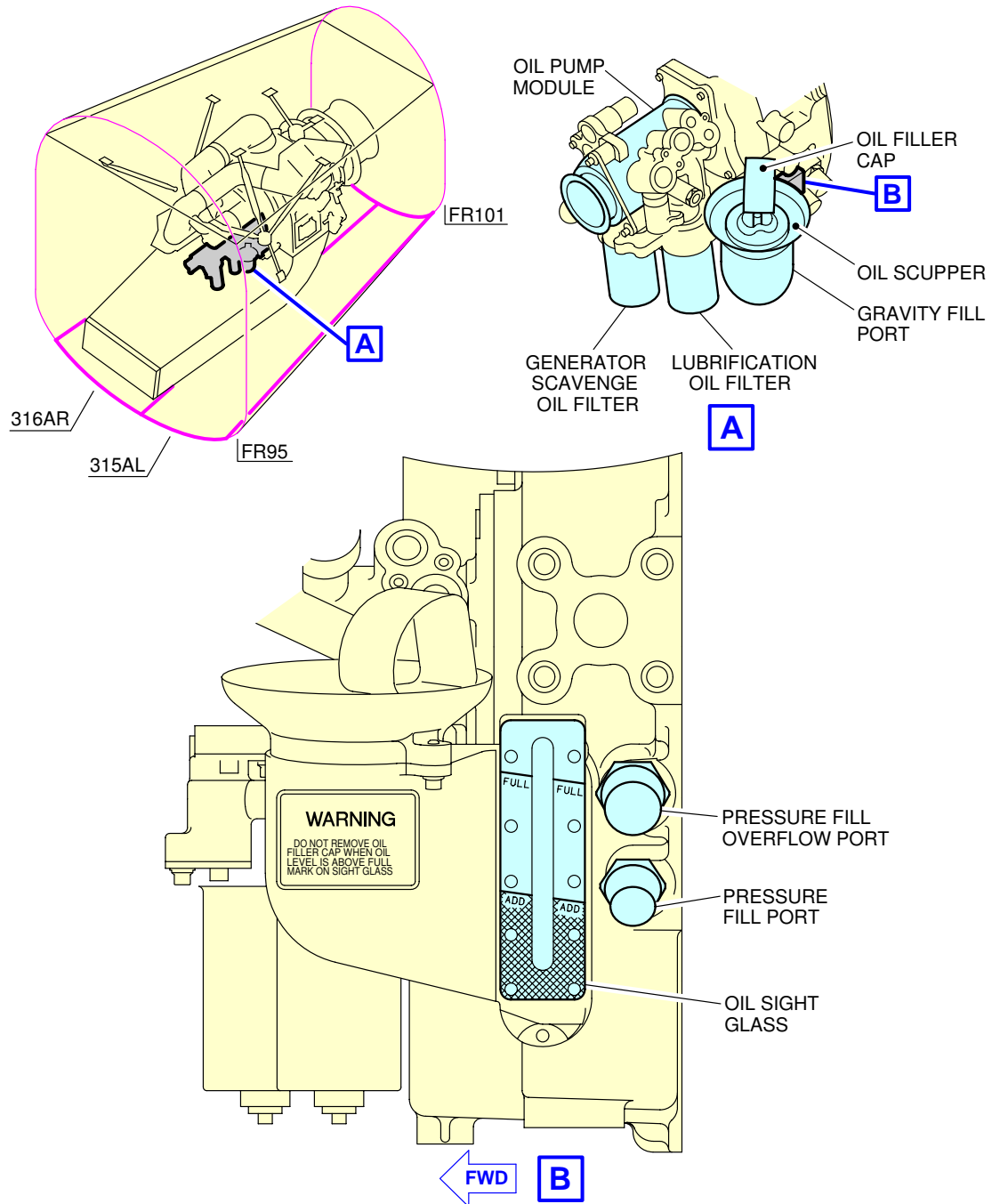

F_AC_050408_1_0100101_01_00

Ground Service Connections
 APU Oil Servicing
 FIGURE-5-4-8-991-010-A01

5-4-9 Potable Water System

****ON A/C A330-300 A330-900**

Potable Water Servicing

1. Potable Water Servicing

NOTE : The mean height from ground in the below table may change according to the CG position and aircraft weight.

ACCESS	DISTANCE			MEAN HEIGHT FROM GROUND
	AFT OF NOSE	FROM AIRCRAFT CENTERLINE		
		LH SIDE	RH SIDE	
Potable-Water Service Panel: Access Door 164AR	48.15 m (157.97 ft)		0.51 m (1.67 ft)	3.15 m (10.33 ft)
FWD Drain Panel: Access Door 133BL	14.7 m (48.23 ft)	0.6 m (1.97 ft)		1.9 m (6.23 ft)
AFT Drain Panel: Access Door 154AR	40.18 m (131.82 ft)		0.72 m (2.36 ft)	2.46 m (8.07 ft)

NOTE : Distances are approximate.

2. Technical Specifications

A. Connections

- (1) On the potable-water service panel (access door 164AR):
 - One heated 3/4 in. (ISO 17775) quick release filling connection
 - One heated 3/4 in. (ISO 17775) overflow and discharge connection
 - One ground pressurization connection.
- (2) On the FWD drain panel (access door 133BL):
 - One standard 3/4 in. (ISO 17775) drain connection with back-up mechanical control.
- (3) On the AFT drain panel (access door 154AR):
 - One standard 3/4 in. (ISO 17775) drain connection with back-up mechanical control
 - One standard 3/4 in. (ISO 17775) overflow and discharge connection with back-up mechanical control.

B. Capacity

- 700 l (184.92 US gal) standard
- 1 050 l (277.38 US gal) standard option.

C. Filling Pressure and Flow Rate

FWD tank:

- Maximum filling pressure: 3.45/8.62 bar (50/125 psi)

- Flow rate: 45/73 l/min (11.89/19.28 US gal/min).

AFT tank:

- Maximum filling pressure: 3.45/8.62 bar (50/125 psi)
- Flow rate: 56/85 l/min (14.79/22.45 US gal/min).

**ON A/C A330-300 A330-900

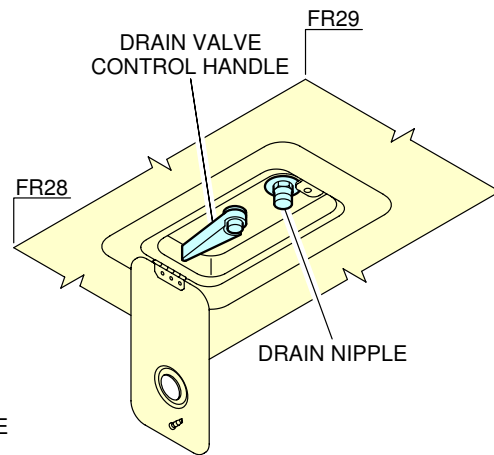
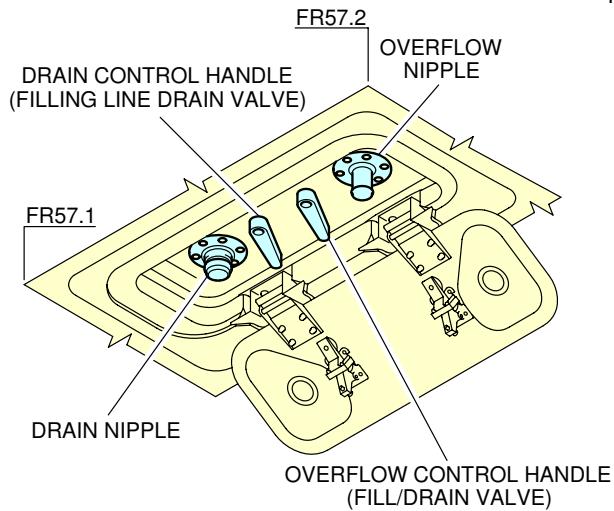
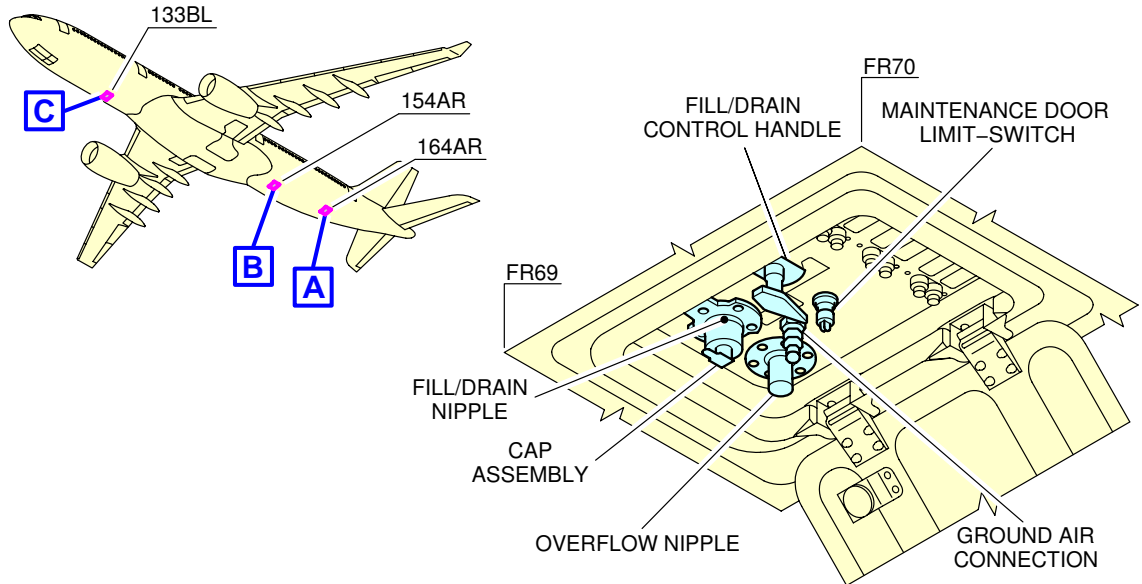

F_AC_050409_1_0150101_01_00

Ground Service Connections
 Potable-Water Ground Service Panels
 FIGURE-5-4-9-991-015-A01

**ON A/C A330-300 A330-900

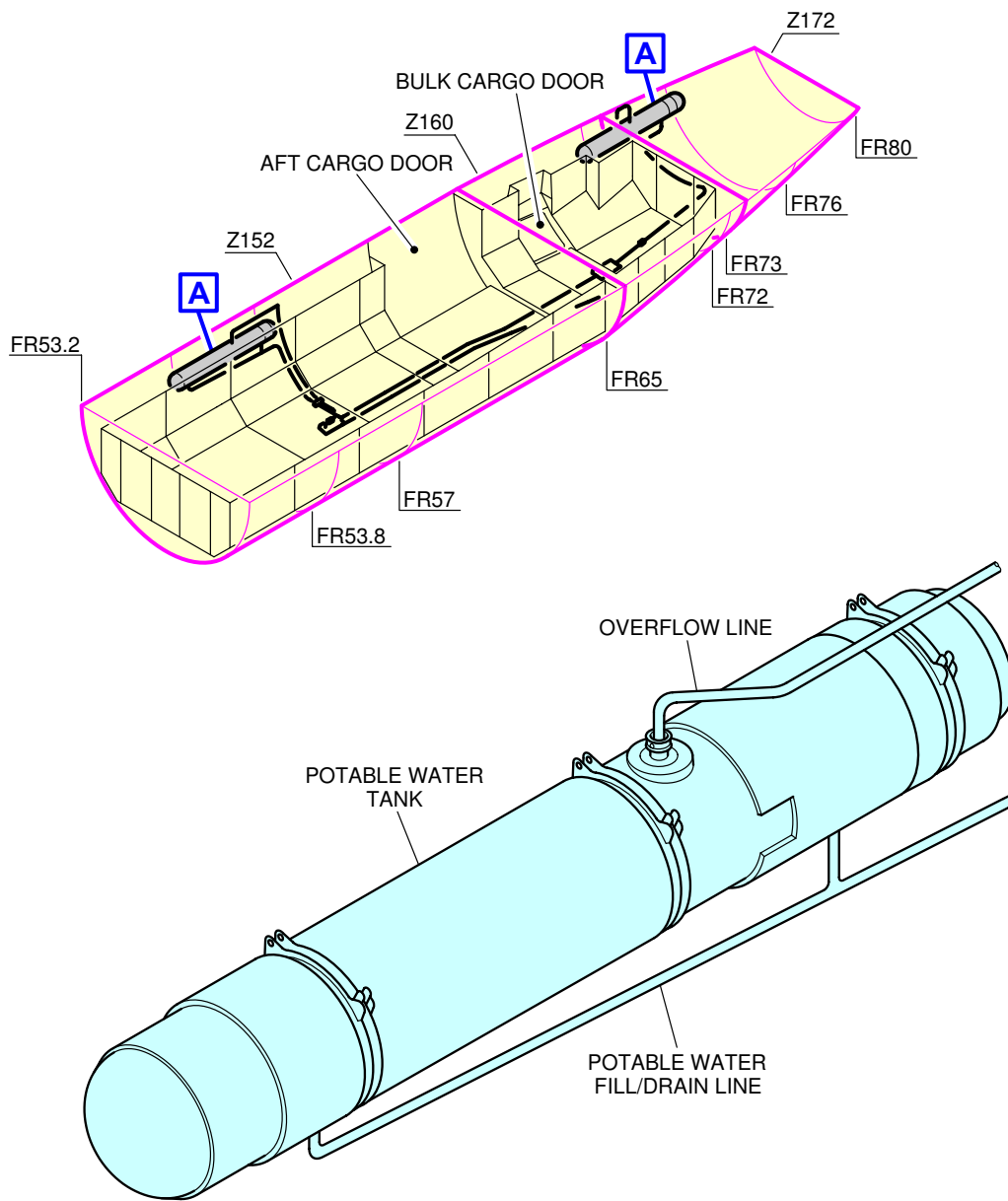

A 01

NOTE:
01 TYPICAL

F_AC_050409_1_0160101_01_00

Ground Service Connections
Potable-Water Tanks Location
FIGURE-5-4-9-991-016-A01

****ON A/C A330-200 A330-800**

Potable Water Servicing

1. Potable Water Servicing

NOTE : The mean height from ground in the below table may change according to the CG position and aircraft weight.

ACCESS	DISTANCE			MEAN HEIGHT FROM GROUND
	AFT OF NOSE	FROM AIRCRAFT CENTERLINE		
		LH SIDE	RH SIDE	
Potable-Water Service Panel: Access Door 164AR	48.15 m (157.97 ft)		0.51 m (1.67 ft)	3.15 m (10.33 ft)
FWD Drain Panel: Access Door 133BL	14.7 m (48.23 ft)	0.6 m (1.97 ft)		1.9 m (6.23 ft)
AFT Drain Panel: Access Door 154AR	40.18 m (131.82 ft)		0.72 m (2.36 ft)	2.46 m (8.07 ft)

NOTE : Distances are approximate.

2. Technical Specifications

A. Connections

- (1) On the potable-water service panel (access door 164AR):
 - One heated 3/4 in. (ISO 17775) quick release filling connection
 - One heated 3/4 in. (ISO 17775) overflow and discharge connection
 - One ground pressurization connection.
- (2) On the FWD drain panel (access door 133BL):
 - One standard 3/4 in. (ISO 17775) drain connection with back-up mechanical control.
- (3) On the AFT drain panel (access door 154AR):
 - One standard 3/4 in. (ISO 17775) drain connection with back-up mechanical control
 - One standard 3/4 in. (ISO 17775) overflow and discharge connection with back-up mechanical control.

B. Capacity

- 700 l (184.92 US gal) standard
- 1 050 l (277.38 US gal) standard option.

C. Filling Pressure and Flow Rate

FWD tank:

- Maximum filling pressure: 3.45/8.62 bar (50/125 psi)
- Flow rate: 45/73 l/min (11.89/19.28 US gal/min).

AFT tank:

- Maximum filling pressure: 3.45/8.62 bar (50/125 psi)
- Flow rate: 56/85 l/min (14.79/22.45 US gal/min).

**ON A/C A330-200 A330-800

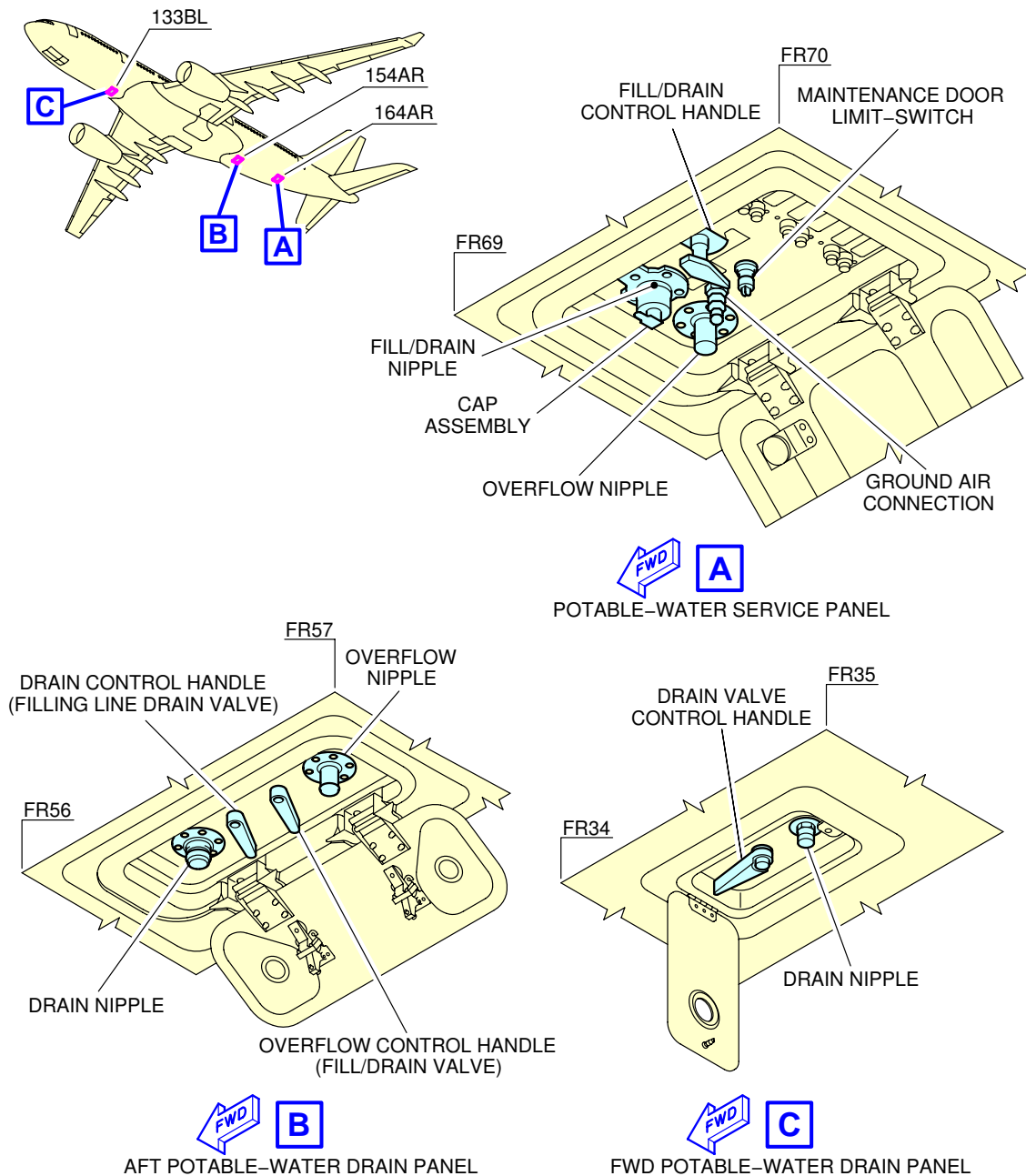

F_AC_050409_1_0210101_01_00

Ground Service Connections
Potable-Water Ground Service Panels
FIGURE-5-4-9-991-021-A01

**ON A/C A330-200 A330-800

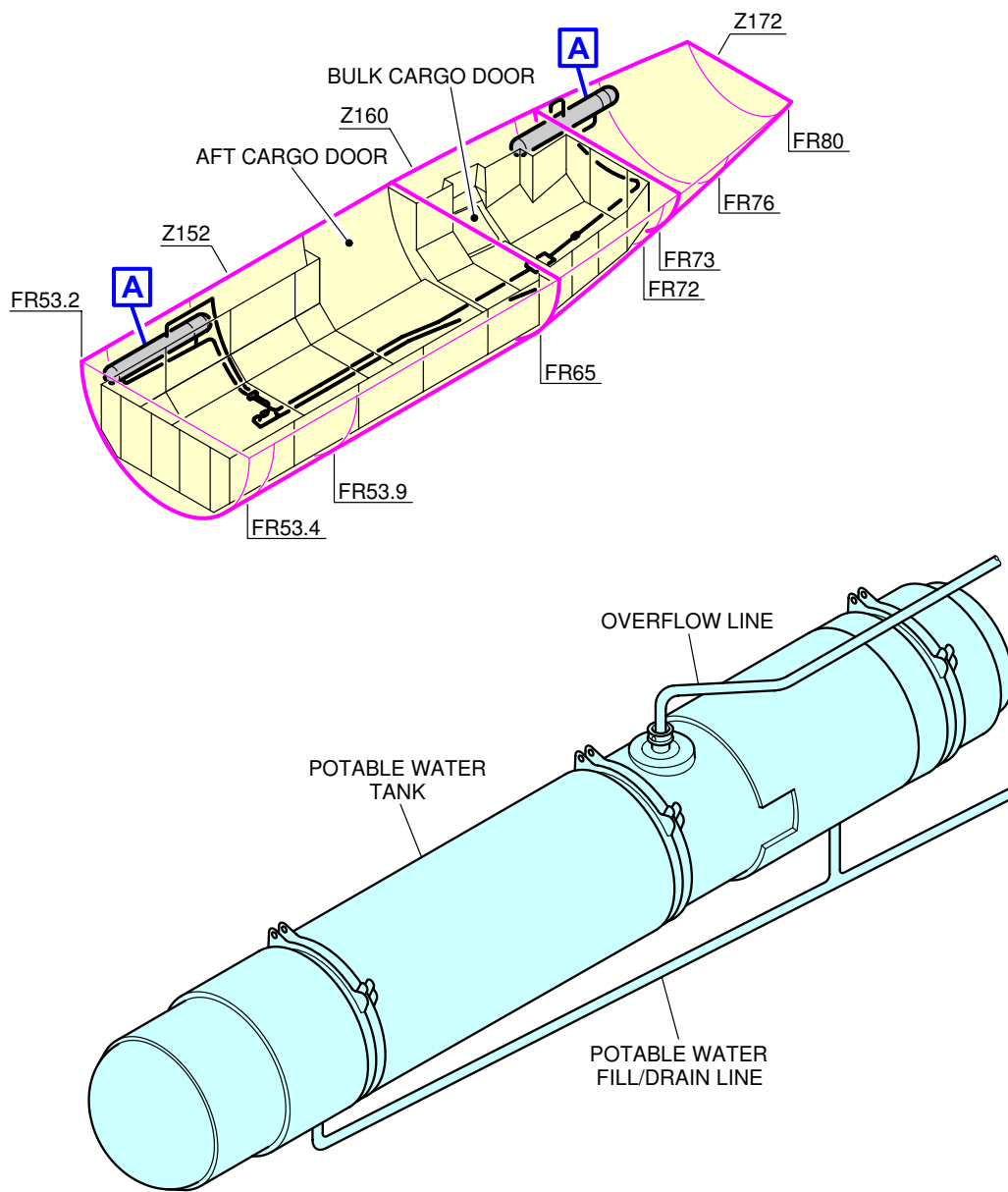

A 01

NOTE:
01 TYPICAL

F_AC_050409_1_0220101_01_00

Ground Service Connections
Potable-Water Tanks Location
FIGURE-5-4-9-991-022-A01

****ON A/C A330-200F**

Potable Water Servicing

1. Potable Water Servicing

NOTE : The mean height from ground in the below table may change according to the CG position and aircraft weight.

ACCESS	DISTANCE			MEAN HEIGHT FROM GROUND
	AFT OF NOSE	FROM AIRCRAFT CENTERLINE		
		LH SIDE	RH SIDE	
Potable-Water Service Panel: Access Door 133BL	14.03 m (46.03 ft)	0.76 m (2.49 ft)		2.64 m (8.66 ft)

NOTE : Distances are approximate.

2. Technical Specifications

A. Connections

- (1) On the potable-water service panel (access door 133BL):
 - One heated 3/4 in. (ISO 17775) quick release filling connection
 - One heated 3/4 in. (ISO 17775) overflow and discharge connection
 - One ground pressurization connection.
- (2) On the drain panel (access door 133BL):
 - One standard 3/4 in. (ISO 17775) drain connection with back-up mechanical control.

B. Capacity

- 100 l (26.42 US gal).

C. Filling Pressure and Flow Rate

- Maximum filling pressure: 3.45 bar (50 psi)
- Flow rate: 45 l/min (11.89 US gal/min).

**ON A/C A330-200F

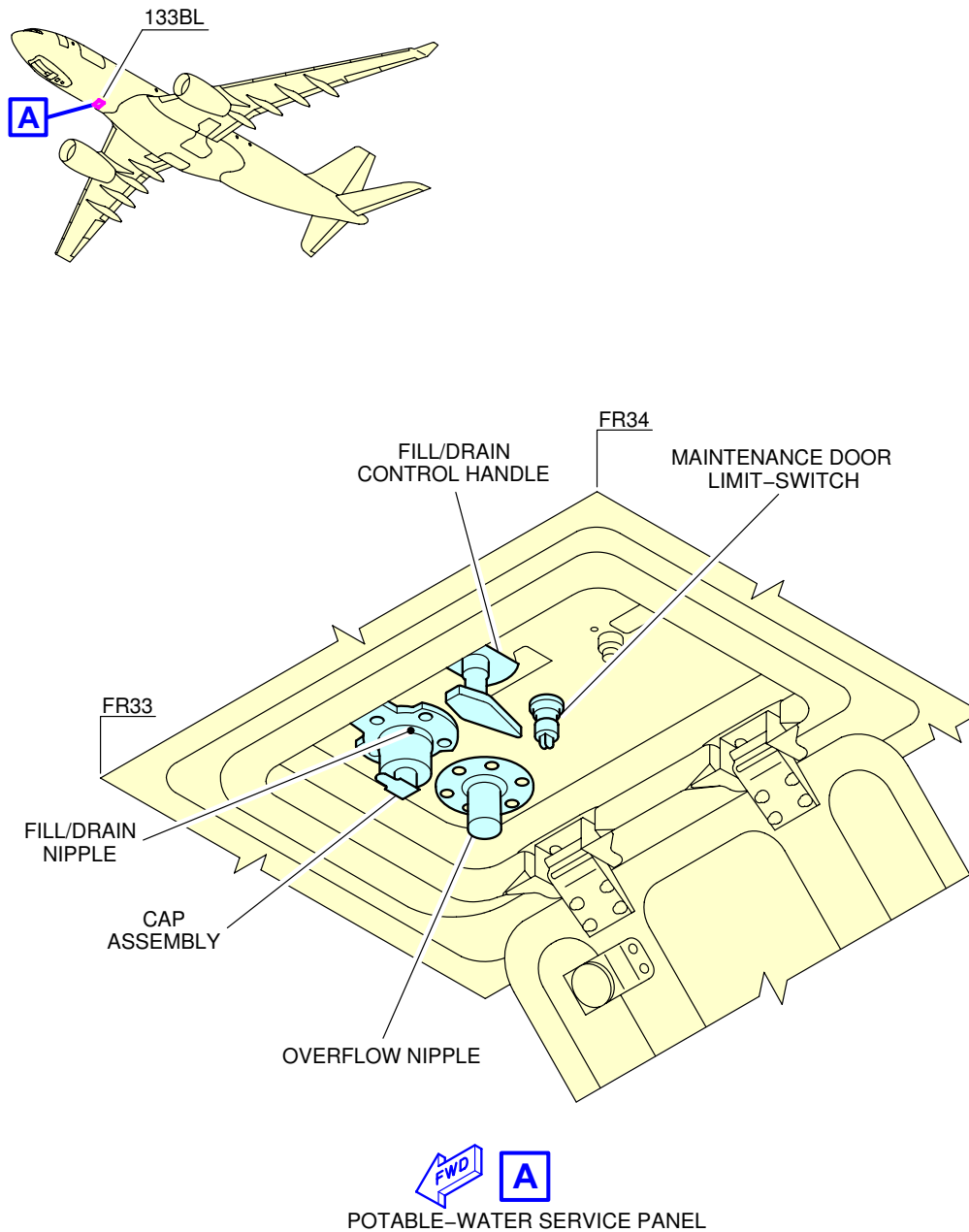

F_AC_050409_1_0250101_01_00

Ground Service Connections
Potable-Water Ground Service Panel
FIGURE-5-4-9-991-025-A01

**ON A/C A330-200F

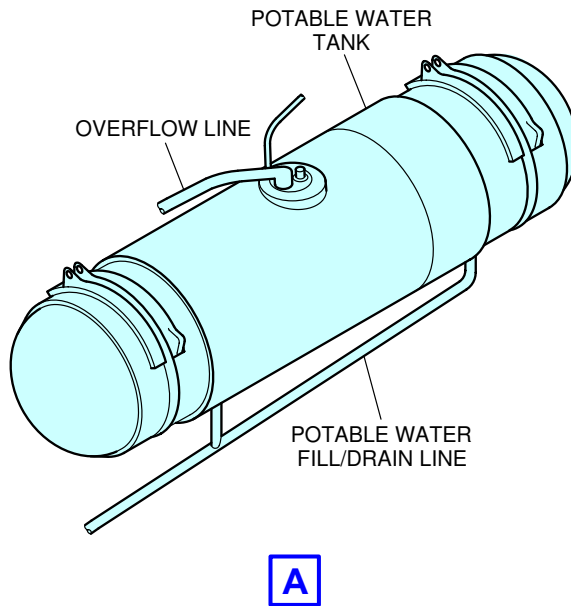
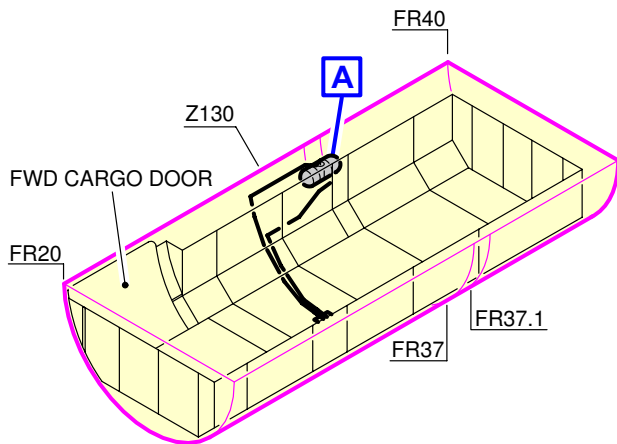

F_AC_050409_1_0260101_01_00

Ground Service Connections
Potable-Water Tank Location
FIGURE-5-4-9-991-026-A01

5-4-10 Waste Water System

****ON A/C A330-200 A330-200F A330-300 A330-800 A330-900**

Waste Water Servicing

****ON A/C A330-300 A330-900**

1. Waste Water Servicing

NOTE : The mean height from ground in the below table may change according to the CG position and aircraft weight.

ACCESS	DISTANCE			MEAN HEIGHT FROM GROUND
	AFT OF NOSE	FROM AIRCRAFT CENTERLINE		
		LH SIDE	RH SIDE	
Waste Water Ground Service Panel: Access Door 171AL	50.00 m (164.04 ft)	0.09 m (0.30 ft)		3.60 m (11.81 ft)

- A. Waste water ground service panel comprising:
 - Standard: One standard 4 in. (ISO 17775) drain connection and two 1 in. (ISO 17775) flushing connections
 - Standard option: One standard 4 in. (ISO 17775) drain connection and three 1 in. (ISO 17775) flushing connections.
- B. Capacity waste tanks:
 - Standard: 700 l (184.92 US gal)
 - Standard option: 1050 l (277.38 US gal).
- C. Chemical fluid:
 - Standard: 36 l (9.51 US gal)
 - Standard option: 54 l (14.27 US gal).

****ON A/C A330-200 A330-800**

2. Waste Water Servicing

NOTE : The mean height from ground in the below table may change according to the CG position and aircraft weight.

ACCESS	DISTANCE			MEAN HEIGHT FROM GROUND
	AFT OF NOSE	FROM AIRCRAFT CENTERLINE		
		LH SIDE	RH SIDE	
Waste Water Ground Service Panel: Access Door 171AL	44.66 m (146.52 ft)	0.09 m (0.30 ft)		3.60 m (11.81 ft)

- A. Waste water ground service panel comprising:
 - Standard: One standard 4 in. (ISO 17775) drain connection and two 1 in. (ISO 17775) flushing connections
 - Standard option: One standard 4 in. (ISO 17775) drain connection and three 1 in. (ISO 17775) flushing connections.
- B. Capacity waste tanks:
 - Standard: 700 l (184.92 US gal)
 - Standard option: 1050 l (277.38 US gal).
- C. Chemical fluid:
 - Standard: 36 l (9.51 US gal)
 - Standard option: 54 l (14.27 US gal).

****ON A/C A330-200F**

3. Waste Water Servicing

NOTE : The mean height from ground in the below table may change according to the CG position and aircraft weight.

ACCESS	DISTANCE			MEAN HEIGHT FROM GROUND
	AFT OF NOSE	FROM AIRCRAFT CENTERLINE		
		LH SIDE	RH SIDE	
Waste Water Ground Service Panel 1: Access Door 121EL	5.49 m (18.01 ft)	1.43 m (4.69 ft)		2.95 m (9.68 ft)
Waste Water Ground Service Panel 2: Access Door 121FL	5.98 m (19.62 ft)	1.69 m (5.54 ft)		3.15 m (10.33 ft)

- A. There are two waste water ground service panels:
 - First panel: One standard connection Roylyn 1 in. (ISO 17775) for flushing and filling
 - Second panel: One standard Taco type valve 4 in. (ISO 17775) for draining.

NOTE : Handle used for drainage is located on the first panel.

- B. Capacity waste tanks:
- Standard: 35 l (9.25 US gal).

NOTE : The waste water drain-system discards the waste water from the galley sink and the lavatory washbasin overboard.
The toilet system moves the waste materials and liquids from the toilet to the waste tank.

- C. Chemical fluid:
- Standard: 9.5 l (2.51 US gal).

**ON A/C A330-200 A330-300 A330-800 A330-900

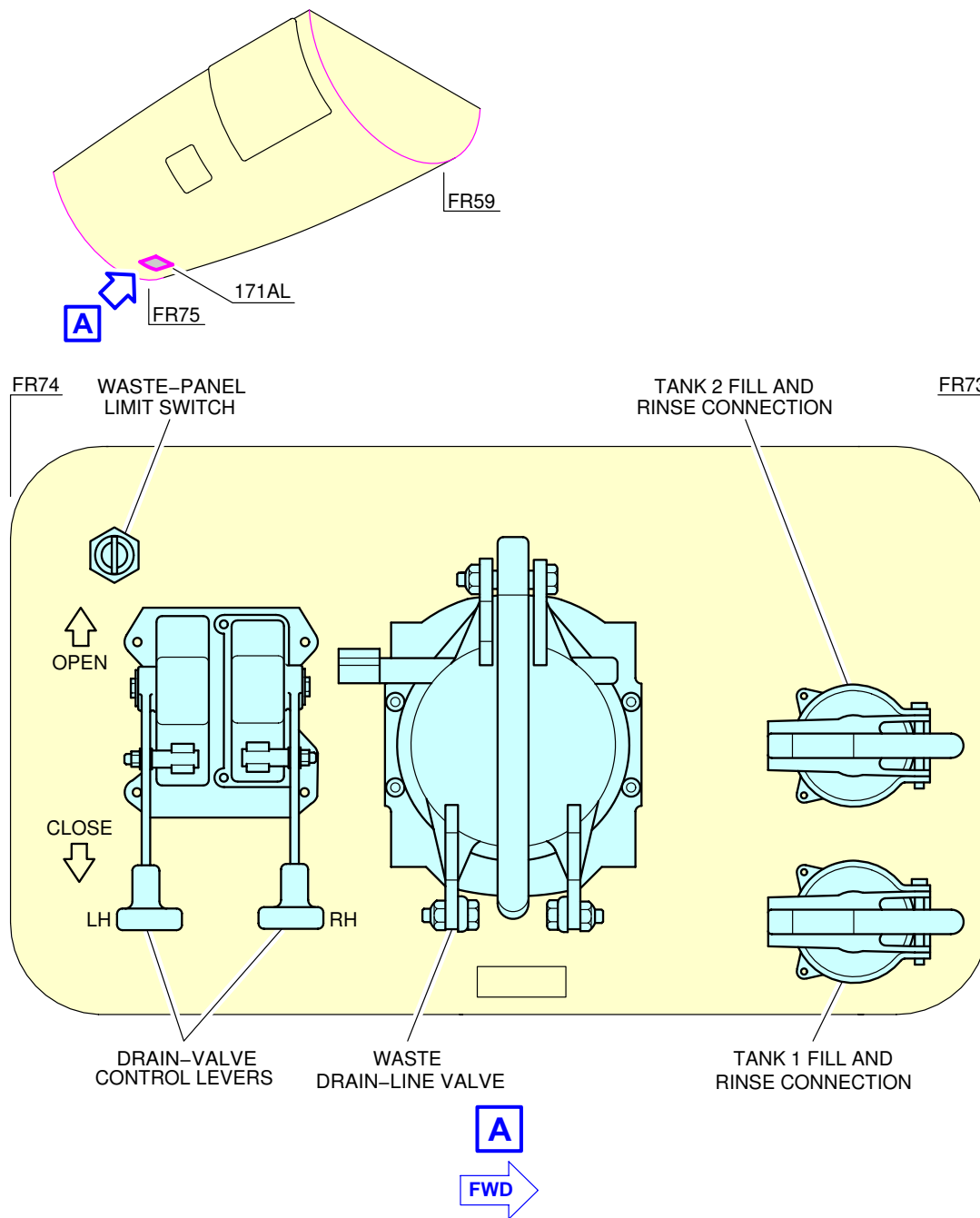

F_AC_050410_1_0010101_01_00

Ground Service Connections
 Waste Water Ground Service Panel
 FIGURE-5-4-10-991-001-A01

**ON A/C A330-200F

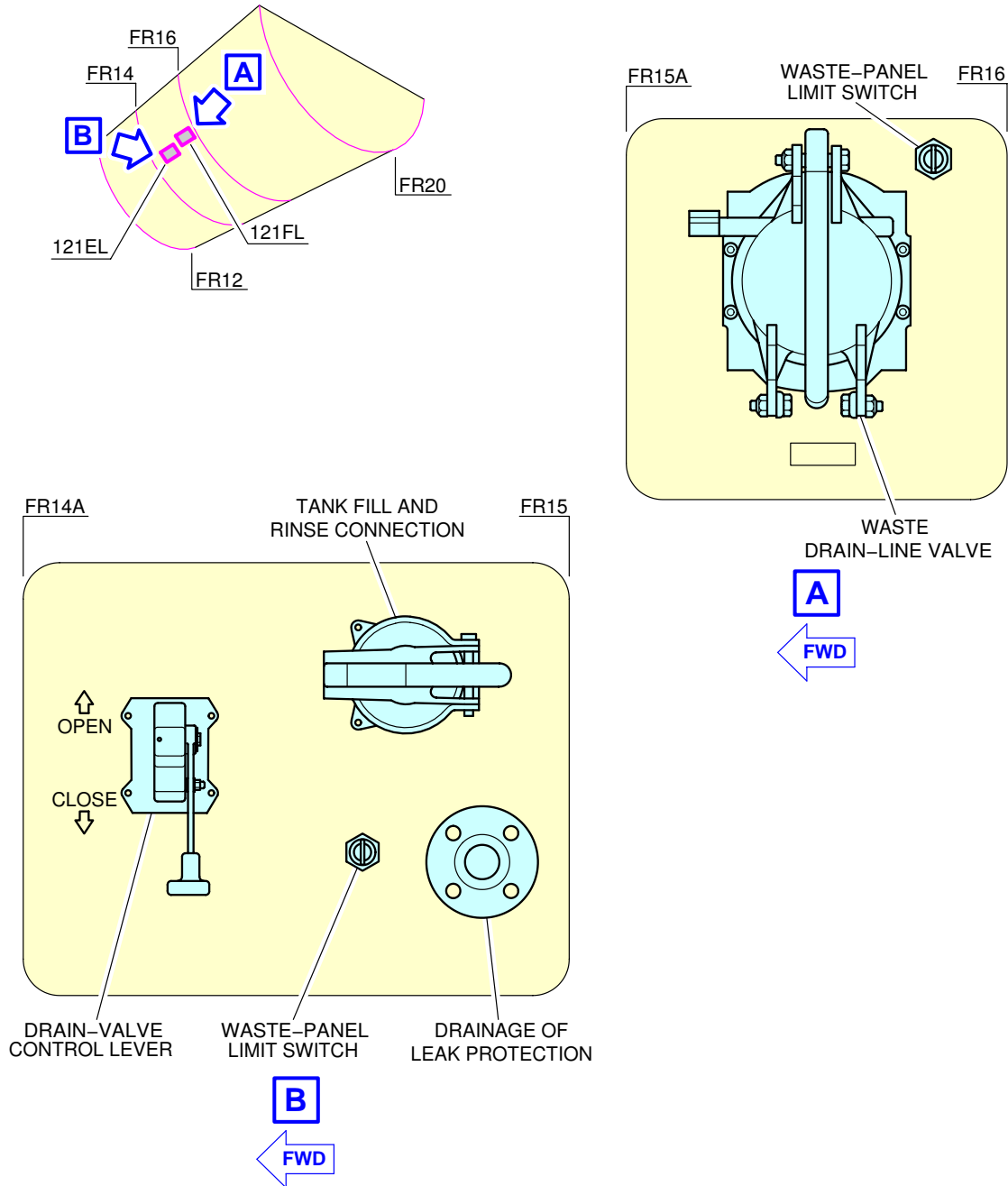

F_AC_050410_1_0040101_01_00

Ground Service Connections
 Waste Water Ground Service Panel
 FIGURE-5-4-10-991-004-A01

**ON A/C A330-200 A330-300 A330-800 A330-900

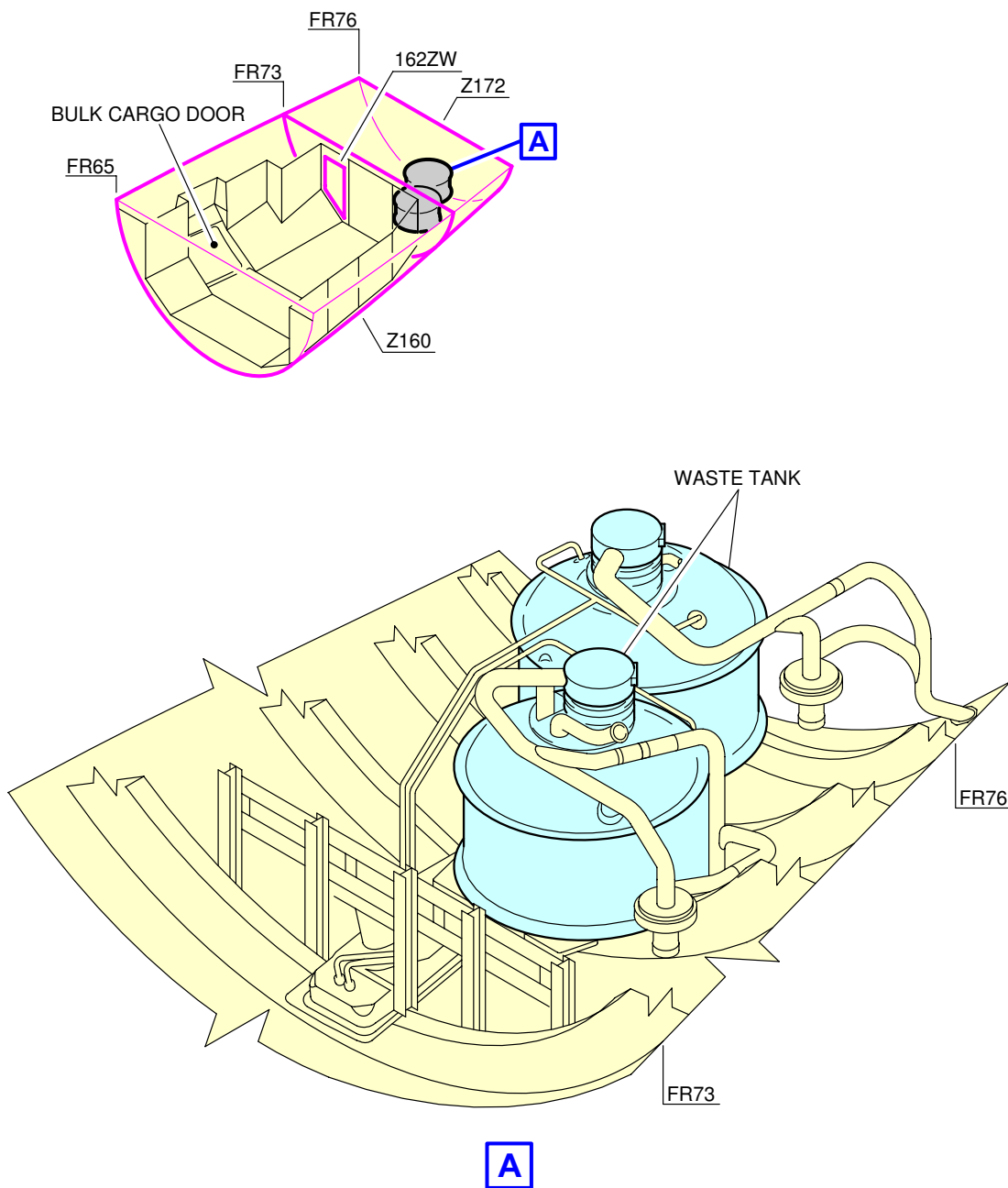

F_AC_050410_1_0050101_01_00

Ground Service Connections
Waste Tanks Location
FIGURE-5-4-10-991-005-A01

5-4-11 Cargo Control Panels

****ON A/C A330-200 A330-200F A330-300 A330-800 A330-900**

Cargo Control Panels

****ON A/C A330-300 A330-900**

1. Cargo Control Panels

NOTE : The mean height from ground in the below table may change according to the CG position and aircraft weight.

ACCESS	DISTANCE			
	AFT OF NOSE	FROM AIRCRAFT CENTERLINE		MEAN HEIGHT FROM GROUND
		LH SIDE	RH SIDE	
FWD CLS* Panel: Access Door 122DR	14.17 m (46.49 ft)		2.60 m (8.53 ft)	3.90 m (12.80 ft)
FWD Cargo Door Panel: Access Door 122CR	13.87 m (45.51 ft)		2.40 m (7.87 ft)	3.30 m (10.83 ft)
AFT CLS* Panel: Access Door 152MR	48.95 m (160.60 ft)		2.60 m (8.53 ft)	4.60 m (15.09 ft)
AFT Cargo Door Panel: Access Door 152NR	48.65 m (159.61 ft)		2.40 m (7.87 ft)	4.00 m (13.12 ft)

NOTE : * CLS - CARGO LOADING SYSTEMS

****ON A/C A330-200 A330-800**

2. Cargo Control Panels

NOTE : The mean height from ground in the below table may change according to the CG position and aircraft weight.

ACCESS	DISTANCE			
	AFT OF NOSE	FROM AIRCRAFT CENTERLINE		MEAN HEIGHT FROM GROUND
		LH SIDE	RH SIDE	
FWD CLS* Panel: Access Door 122DR	14.17 m (46.49 ft)		2.60 m (8.53 ft)	3.98 m (13.06 ft)
FWD Cargo Door Panel: Access Door 122CR	13.87 m (45.51 ft)		2.40 m (7.87 ft)	3.38 m (11.09 ft)

ACCESS	DISTANCE			
	AFT OF NOSE	FROM AIRCRAFT CENTERLINE		MEAN HEIGHT FROM GROUND
		LH SIDE	RH SIDE	
AFT CLS* Panel: Access Door 152MR	43.63 m (143.14 ft)		2.60 m (8.53 ft)	4.70 m (15.42 ft)
AFT Cargo Door Panel: Access Door 152NR	43.33 m (142.16 ft)		2.40 m (7.87 ft)	4.10 m (13.45 ft)

NOTE : * CLS - CARGO LOADING SYSTEMS

****ON A/C A330-200F**

3. Cargo Control Panels

NOTE : The mean height from ground in the below table may change according to the CG position and aircraft weight.

ACCESS	DISTANCE			
	AFT OF NOSE	FROM AIRCRAFT CENTERLINE		MEAN HEIGHT FROM GROUND
		LH SIDE	RH SIDE	
FWD CLS* Panel: Access Door 122DR	14.17 m (46.49 ft)		2.60 m (8.53 ft)	4.31 m (14.14 ft)
FWD Cargo Door Panel: Access Door 122CR	13.87 m (45.51 ft)		2.40 m (7.87 ft)	3.71 m (12.17 ft)
AFT CLS* Panel: Access Door 152MR	43.63 m (143.14 ft)		2.60 m (8.53 ft)	4.70 m (15.42 ft)
AFT Cargo Door Panel: Access Door 152NR	43.33 m (142.16 ft)		2.40 m (7.87 ft)	4.10 m (13.45 ft)

NOTE : * CLS - CARGO LOADING SYSTEMS

****ON A/C A330-200 A330-200F A330-300 A330-800 A330-900**

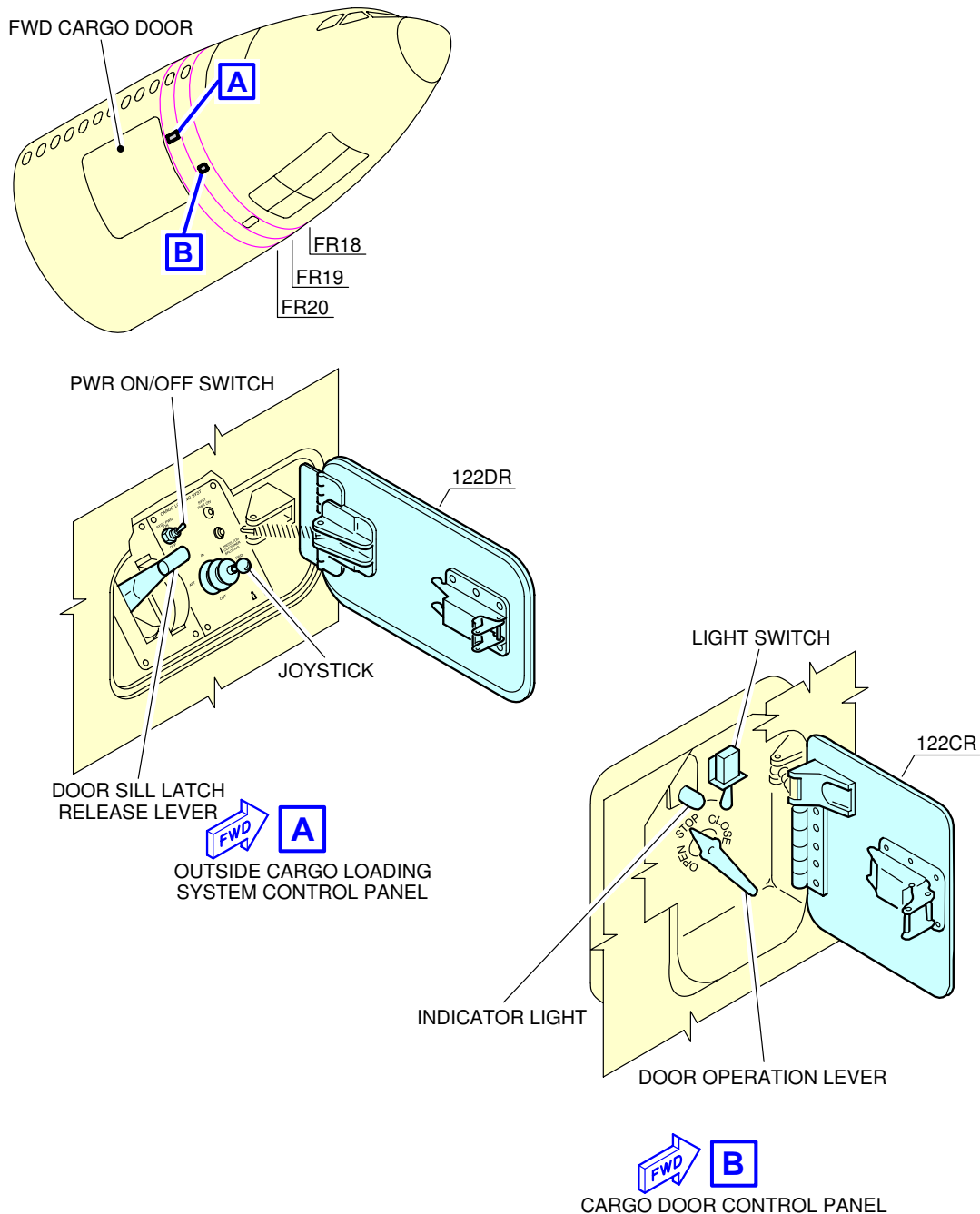

F_AC_050411_1_0010101_01_00

Forward Cargo Control Panels
FIGURE-5-4-11-991-001-A01

**ON A/C A330-200 A330-200F A330-300 A330-800 A330-900

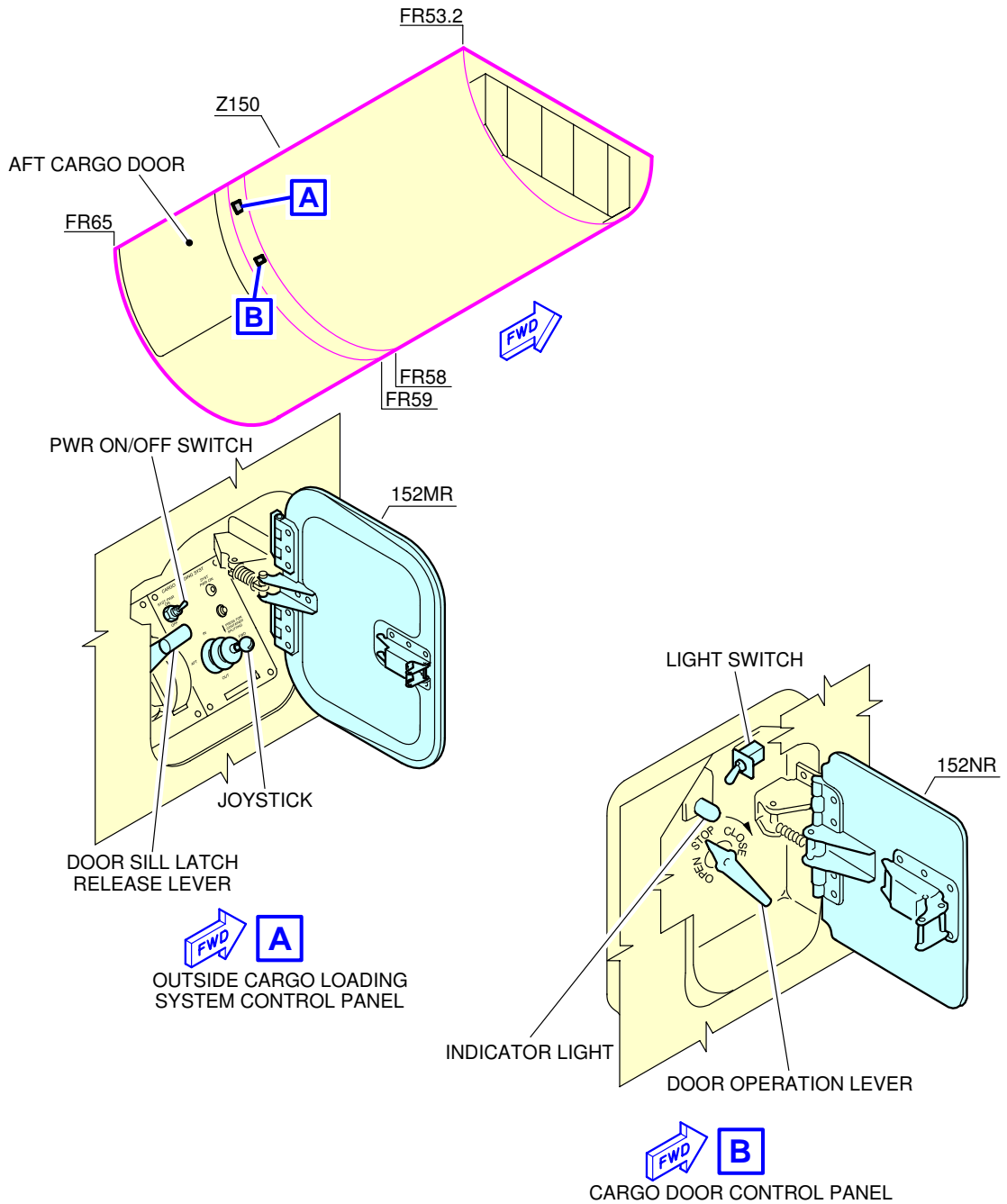

F_AC_050411_1_0020101_01_00

Aft Cargo Control Panels
FIGURE-5-4-11-991-002-A01

**ON A/C A330-200F

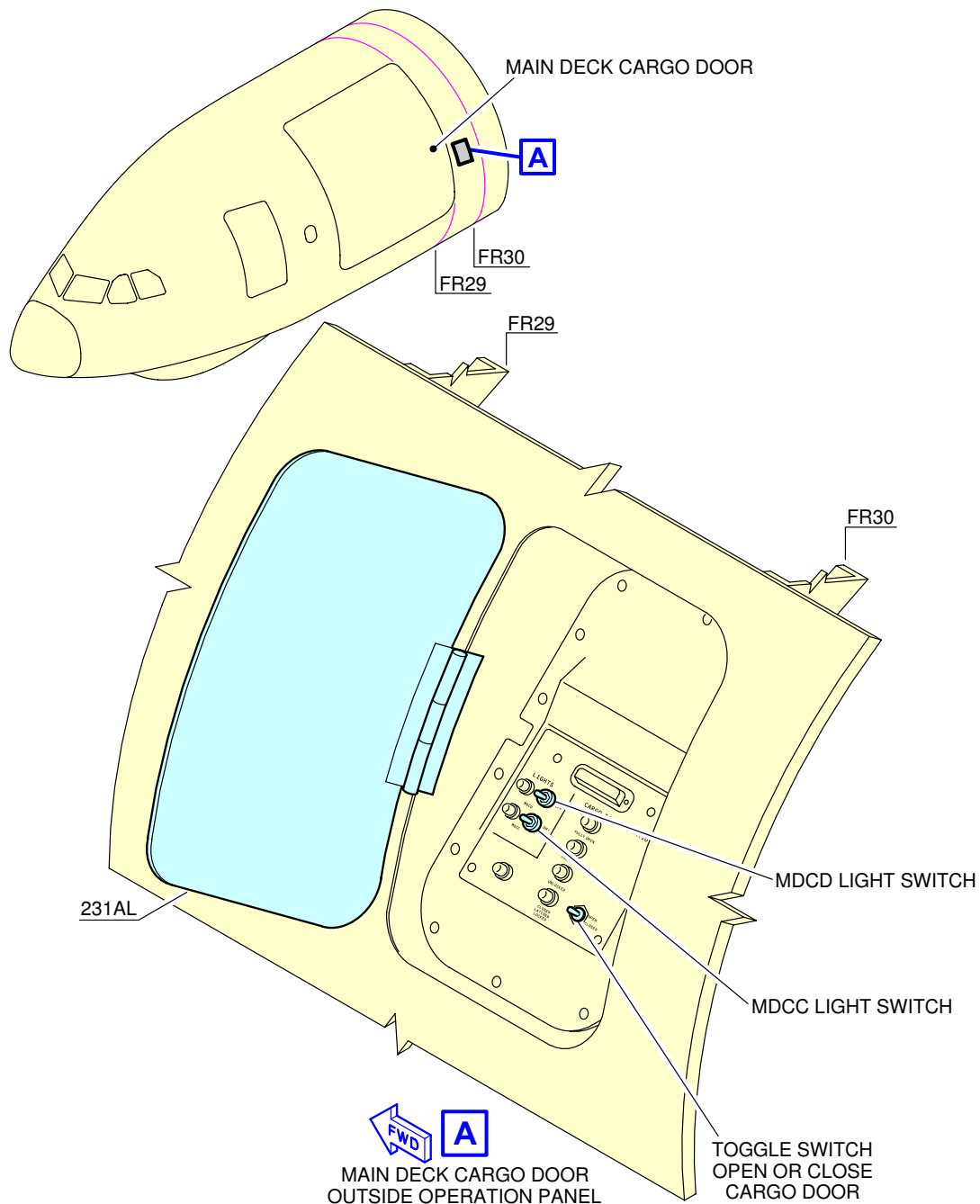

F_AC_050411_1_0030101_01_00

Main Deck Cargo Control Panel
FIGURE-5-4-11-991-003-A01

5-5-0 Engine Starting Pneumatic Requirements

****ON A/C A330-200 A330-200F A330-300 A330-800 A330-900**

Engine Starting Pneumatic Requirements

1. The purpose of this section gives the minimum air-data requirements (airflow and temperature) at the aircraft connection for a main engine start at sea level.

ABBREVIATION	DEFINITION
ASU	Air Start Unit
HPGC	High Pressure Ground Connection
OAT	Outside Air Temperature

- A. The pressure at HPGC must not be more than 60 psig (75 psia) and less than 33 psig (48 psia). The temperature must be less than 220 °C (428 °F).
- B. The recommended pressure at HPGC is 40 psig (55 psia).
- C. The OAT and the ASU performances (see the technical data from the ASU manufacturer) effect the ASU output temperature.
- D. If necessary, connect two ASUs in parallel which gives the same pressure (one for each HPGC) to supply the necessary airflow to the aircraft.
- E. In the altitude, the ASU is less efficient but the engine is less demanding too.

****ON A/C A330-200 A330-300**

2. GE CF6 Engines for an OAT between -40 °C (-40 °F) and 55 °C (131 °F) at Sea Level

ASU OUTPUT TEMPERATURE RANGE	PRESSURE AT HPGC	MASS FLOW AT HPGC
100 °C (212 °F) - 125 °C (257 °F)	40 psig (55 psia)	241 ppm (109 kg/min)
125 °C (257 °F) - 155 °C (311 °F)	40 psig (55 psia)	233 ppm (106 kg/min)
155 °C (311 °F) - 185 °C (365 °F)	40 psig (55 psia)	225 ppm (102 kg/min)
185 °C (365 °F) - 220 °C (428 °F)	40 psig (55 psia)	218 ppm (99 kg/min)

****ON A/C A330-200 A330-200F A330-300**

3. PW 4000 Engines for an OAT between -40 °C (-40 °F) and 55 °C (131 °F) at Sea Level

ASU OUTPUT TEMPERATURE RANGE	PRESSURE AT HPGC	MASS FLOW AT HPGC
100 °C (212 °F) - 125 °C (257 °F)	40 psig (55 psia)	271 ppm (123 kg/min)
125 °C (257 °F) - 155 °C (311 °F)	40 psig (55 psia)	262 ppm (119 kg/min)
155 °C (311 °F) - 185 °C (365 °F)	40 psig (55 psia)	253 ppm (115 kg/min)
185 °C (365 °F) - 220 °C (428 °F)	40 psig (55 psia)	244 ppm (111 kg/min)

4. RR Trent 700 Engines for an OAT between -40 °C (-40 °F) and 55 °C (131 °F) at Sea Level

ASU OUTPUT TEMPERATURE RANGE	PRESSURE AT HPGC	MASS FLOW AT HPGC
100 °C (212 °F) - 125 °C (257 °F)	40 psig (55 psia)	269 ppm (122 kg/min)
125 °C (257 °F) - 155 °C (311 °F)	40 psig (55 psia)	260 ppm (118 kg/min)
155 °C (311 °F) - 185 °C (365 °F)	40 psig (55 psia)	251 ppm (114 kg/min)
185 °C (365 °F) - 220 °C (428 °F)	40 psig (55 psia)	243 ppm (110 kg/min)

****ON A/C A330-800 A330-900**

5. RR Trent 7000 Engines for an OAT between -40 °C (-40 °F) and 55 °C (131 °F) at Sea Level

ASU OUTPUT TEMPERATURE RANGE	PRESSURE AT HPGC	MASS FLOW AT HPGC
100 °C (212 °F) - 125 °C (257 °F)	40 psig (55 psia)	321 ppm (146 kg/min)
125 °C (257 °F) - 155 °C (311 °F)	40 psig (55 psia)	311 ppm (141 kg/min)
155 °C (311 °F) - 185 °C (365 °F)	40 psig (55 psia)	300 ppm (136 kg/min)



AIRCRAFT CHARACTERISTICS - AIRPORT AND MAINTENANCE PLANNING

ASU OUTPUT TEMPERATURE RANGE	PRESSURE AT HPGC	MASS FLOW AT HPGC
185 °C (365 °F) - 220 °C (428 °F)	40 psig (55 psia)	290 ppm (131 kg/min)

5-6-0 Ground Pneumatic Power Requirements

****ON A/C A330-200 A330-200F A330-300 A330-800 A330-900**

Ground Pneumatic Power Requirements

1. General

This section describes the required performance for the ground equipment to maintain the cabin temperature at 27 °C (80.6 °F) for the cooling or 21 °C (69.8 °F) for heating cases after boarding (Section 5.7 - steady state), and provides the time needed to cool down or heat up the aircraft cabin to the required temperature (Section 5.6 - dynamic cases with aircraft empty).

ABBREVIATION	DEFINITION
A/C	Aircraft
AHM	Aircraft Handling Manual
GC	Ground Connection
GSE	Ground Service Equipment
IFE	In-Flight Entertainment
LP	Low Pressure
LPGC	Low Pressure Ground Connection
OAT	Outside Air Temperature
PCA	Pre-Conditioned Air

- A. The air flow rates and temperature requirements for the GSE, provided in Sections 5.6 and 5.7, are given at A/C ground connection.

NOTE : The cooling capacity of the equipment (kW) is only indicative and is not sufficient by itself to ensure the performance (outlet temperature and flow rate combinations are the requirements needed for ground power).

An example of cooling capacity calculation is given in Section 5.7.

- B. The air flow rates and temperature requirements for the GSE are given for the A/C in the configuration "2 LP ducts connected".

NOTE : The maximum air flow is driven by pressure limitation at LPGC.

- C. For temperatures at ground connection below +2 °C (+35.6 °F) (Subfreezing), the ground equipment shall be compliant with the Airbus document "Subfreezing PCA Carts – Compliance Document for Suppliers" (contact Airbus to obtain this document) defining all the requirements with which Subfreezing Pre-Conditioning Air equipment must comply to allow its use on Airbus aircraft. These requirements are in addition to the functional specifications included in the IATA AHM997.

2. Ground Pneumatic Power Requirements

This section provides the ground pneumatic power requirements for:

- Heating (pull up) the cabin, initially at OAT, up to 21 °C (69.8 °F) (see FIGURE 5-6-0-991-001-A)
- Cooling (pull down) the cabin, initially at OAT, down to 27 °C (80.6 °F) (see FIGURE 5-6-0-991-003-A).

****ON A/C A330-200 A330-200F A330-300 A330-800 A330-900**

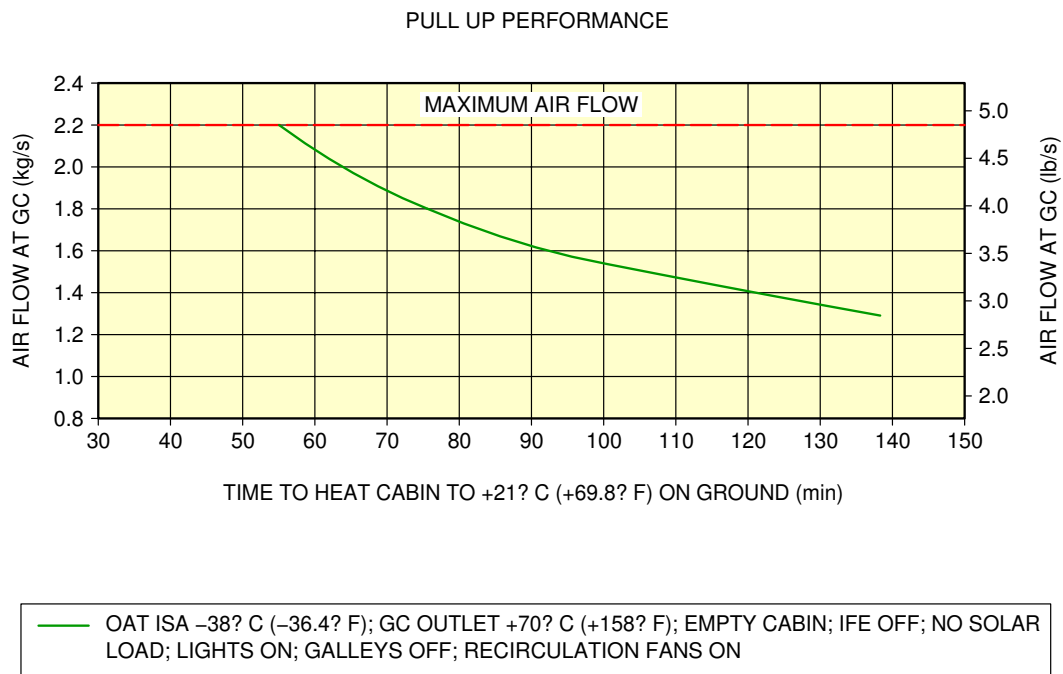

F_AC_050600_1_0010101_01_00

Ground Pneumatic Power Requirements
Heating
FIGURE-5-6-0-991-001-A01

****ON A/C A330-200 A330-200F A330-300 A330-800 A330-900**

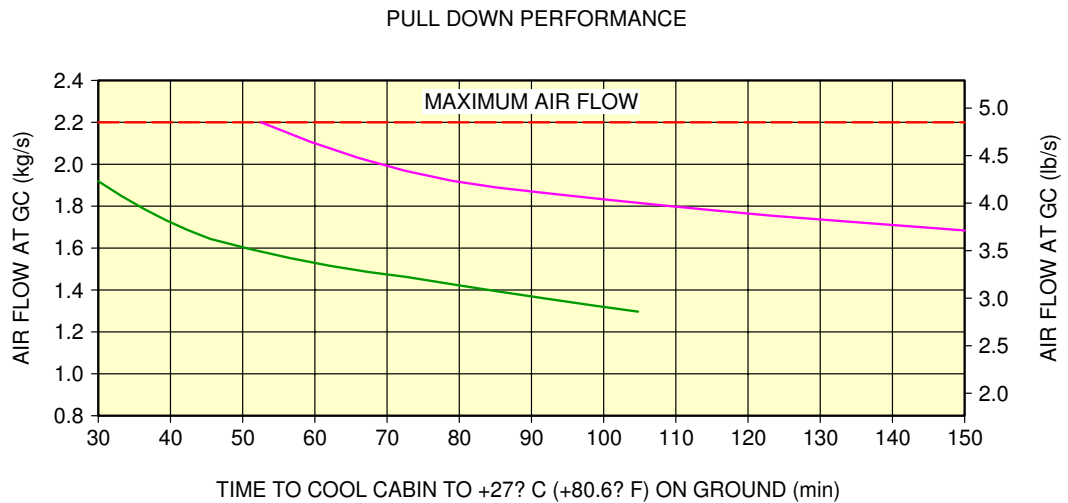

- OAT ISA +23°C (+73.4°F); GC OUTLET +2°C (+35.6°F); EMPTY CABIN; IFE OFF; SOLAR LOAD; LIGHTS ON; GALLEYS OFF; RECIRCULATION FANS ON
- OAT ISA +23°C (+73.4°F); GC OUTLET -10°C (+14°F); EMPTY CABIN; IFE OFF; SOLAR LOAD; LIGHTS ON; GALLEYS OFF; RECIRCULATION FANS ON

NOTE:
ONLY SUPPLY TEMPERATURE ABOVE +2°C (+35.6°F) (NO SUBFREEZING) FOR THE A330-200F.

F_AC_050600_1_0030101_01_00

Ground Pneumatic Power Requirements
Cooling
FIGURE-5-6-0-991-003-A01

5-7-0 Preconditioned Airflow Requirements****ON A/C A330-200 A330-200F A330-300 A330-800 A330-900**Preconditioned Airflow Requirements

1. This section provides the preconditioned airflow rate and temperature needed to maintain the cabin temperature at 27 °C (80.6 °F) for the cooling or 21 °C (69.8 °F) for the heating cases.

These settings are not intended to be used for operation (they are not a substitute for the settings given in the AMM). They are based on theoretical simulations and give the picture of a real steady state.

The purpose of the air conditioning (cooling) operation (described in the AMM) is to maintain the cabin temperature below 27 °C (80.6 °F) during boarding (therefore it is not a steady state).

****ON A/C A330-200 A330-200F A330-300 A330-800 A330-900**

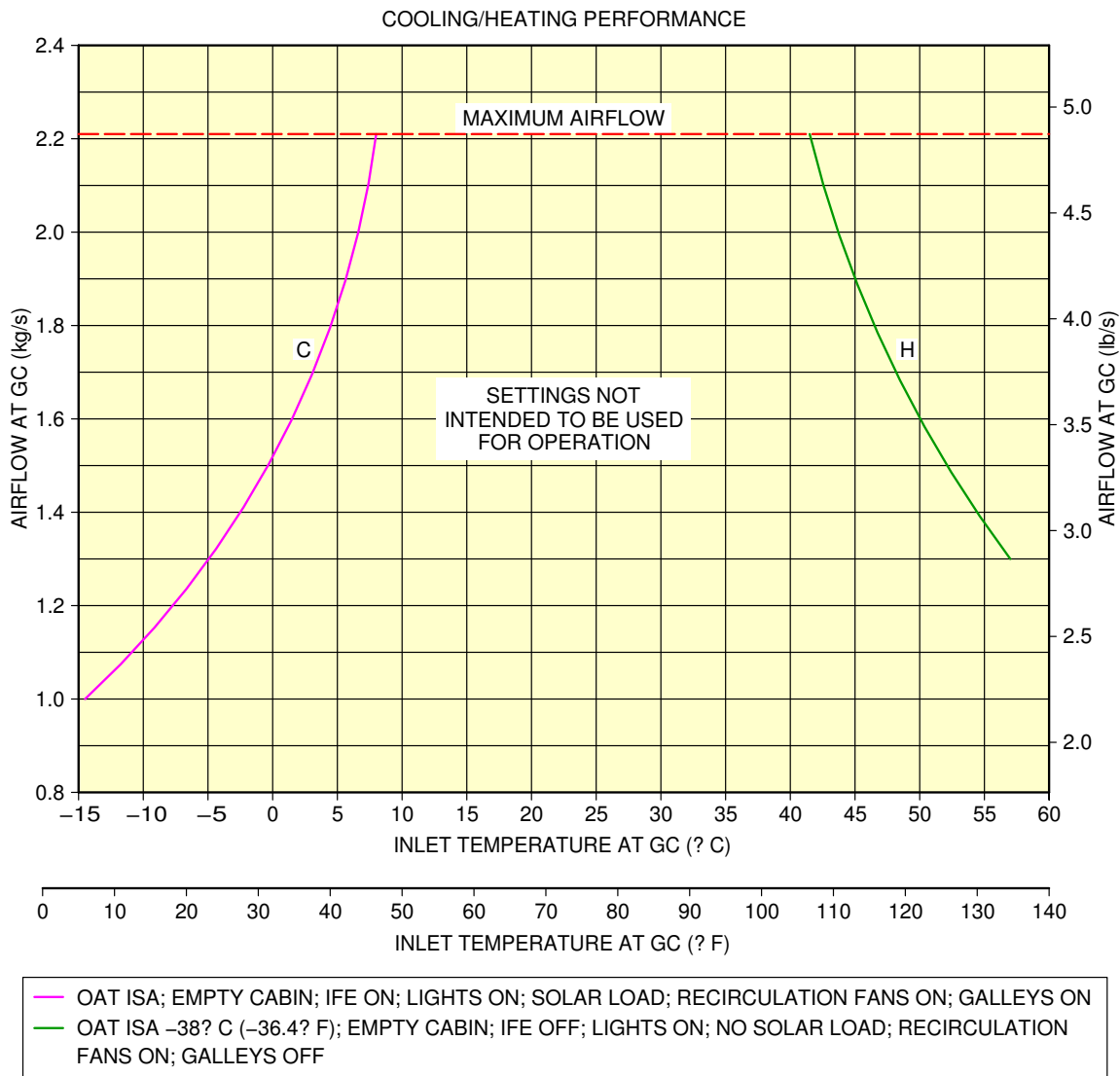

EXAMPLE:

COOLING CAPACITY CALCULATION:

FOR THE CONDITIONS "C", THE COOLING CAPACITY OF $1.9 \text{ kg/s} \times 1 \text{ kJ}/(\text{kg} \cdot \text{°C}) \times (27 - 5) = 41.8 \text{ kW}$ (OR 12.5 TONS COOLING CAPACITY) IS NEEDED TO MAINTAIN THE CABIN TEMPERATURE AT 27° C (80.6° F) (1.9 kg/s AT 5° C (41° F) FOR AIR AT GC INLET).

NOTE:

ONLY SUPPLY TEMPERATURE ABOVE +2° C (+35.6° F) (NO SUBFREEZING) FOR THE A330-200F.

F_AC_050700_1_0010101_01_03

Preconditioned Airflow Requirements
 FIGURE-5-7-0-991-001-A01

5-8-0 Ground Towing Requirements

****ON A/C A330-200 A330-200F A330-300 A330-800 A330-900**

Ground Towing Requirements

1. This section provides information on aircraft towing.

The A330 is designed with means for conventional or towbarless towing. Information/procedures can be found for both in chapter 9 of the Aircraft Maintenance Manual.

Status on towbarless towing equipment qualification can be found in ISI 09.11.00001.

It is possible to tow or push the aircraft, at maximum ramp weight with engines at zero or up to idle thrust, using a towbar attached to the NLG. One towbar fitting is installed at the front of the leg (optional towing fitting for towing from the rear of the NLG available).

The main landing gears have attachment points for towing or debogging (for details, refer ARM 07).

This section shows the chart to determine the drawbar pull and tow tractor mass requirements as a function of the following physical characteristics:

- Aircraft weight,
- Number of engines at idle,
- Slope.

The chart is based on the A330 engine type with the highest idle thrust.

The chart is therefore valid for all A330 models.

2. Towbar design guidelines

The aircraft towbar shall comply with the following standards:

- ISO 8267-1, "Aircraft - Towbar Attachment Fitting - Interface Requirements - Part 1: Main Line Aircraft",
- ISO 9667, "Aircraft Ground Support Equipment - Towbars",
- IATA Airport Handling Manual AHM 958, "Functional Specification for an Aircraft Towbar".

A conventional type towbar is required which should be equipped with a damping system (to protect the NLG against jerks) and with towing shear pins:

- A traction shear pin calibrated at 28 620 daN (64 340 lbf),
- A torsion pin calibrated at 3 130 m.daN (277 028 lbf.in).

The towing head is designed according to ISO 8267-1, cat. III.

****ON A/C A330-200 A330-200F A330-300**

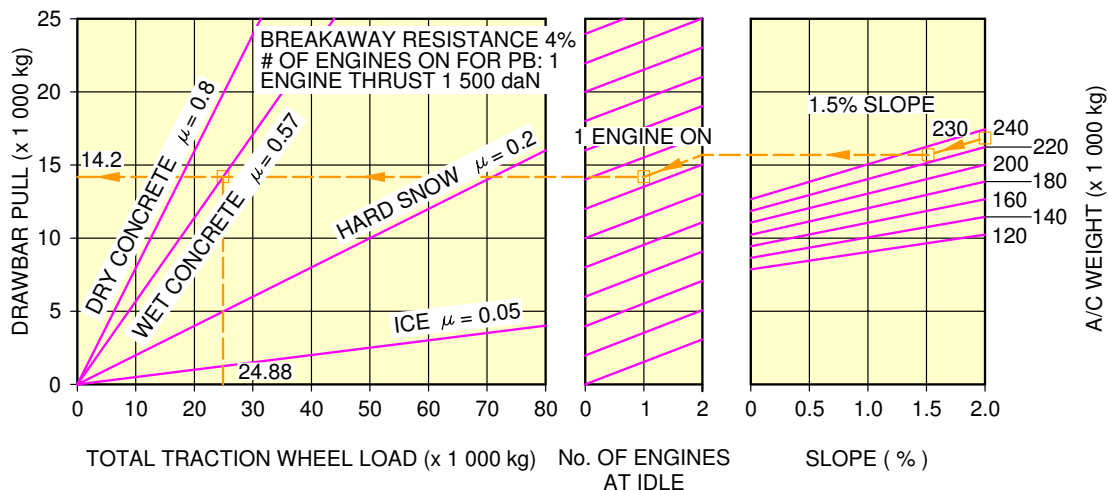

EXAMPLE HOW TO DETERMINE THE MASS REQUIREMENT TO TOW A A330 AT 230 000 kg, AT 1.5% SLOPE, 1 ENGINE AT IDLE AND FOR WET TARMAC CONDITIONS:

- ON THE RIGHT HAND SIDE OF THE GRAPH, CHOOSE THE RELEVANT AIRCRAFT WEIGHT (230 000 kg),
- FROM THIS POINT DRAW A PARALLEL LINE TO THE REQUIRED SLOPE PERCENTAGE (1.5%),
- FROM THE POINT OBTAINED DRAW A STRAIGHT HORIZONTAL LINE UNTIL No. OF ENGINES AT IDLE = 2,
- FROM THIS POINT DRAW A PARALLEL LINE TO THE REQUESTED No. OF ENGINES (1),
- THE Y-COORDINATE OBTAINED IS THE NECESSARY DRAWBAR PULL FOR THE TRACTOR (14 200 kg),
- SEARCH THE INTERSECTION WITH THE "WET CONCRETE" LINE.
- THE OBTAINED X-COORDINATE IS THE RECOMMENDED TOTAL TRACTION WHEEL LOAD (xx xxx kg).

NOTE:

USE A TRACTOR WITH A LIMITED DRAWBAR PULL TO PREVENT LOADS ABOVE THE TOW-BAR SHEAR-PIN CAPACITY.

- SEARCH THE INTERSECTION WITH THE "WET CONCRETE" LINE.
- THE OBTAINED X-COORDINATE IS THE RECOMMENDED TOTAL TRACTION WHEEL LOAD (xx xxx kg).

F_AC_050800_1_0020101_01_04

Ground Towing Requirements
FIGURE-5-8-0-991-002-A01

****ON A/C A330-800 A330-900**

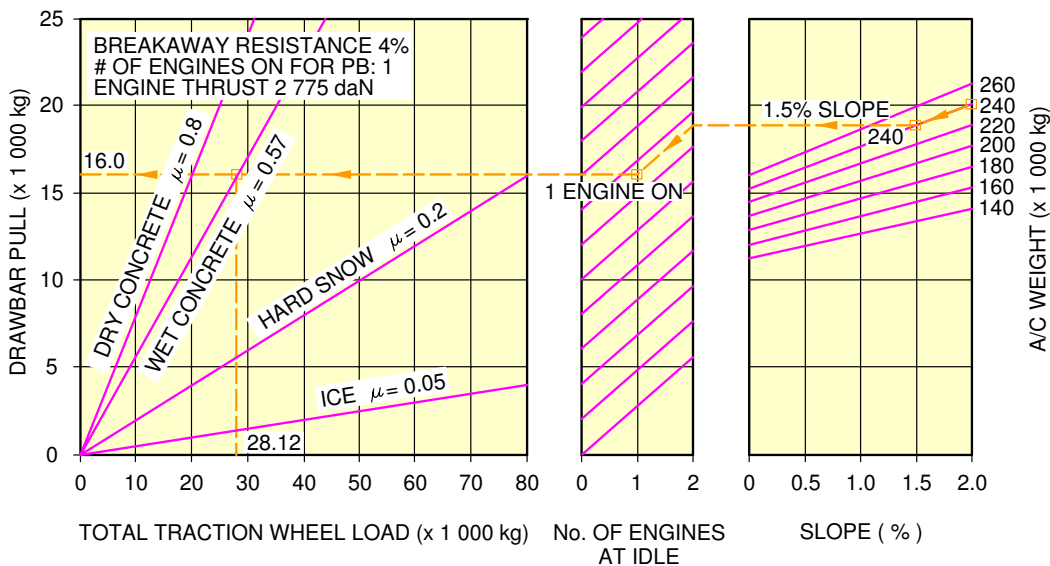

EXAMPLE HOW TO DETERMINE THE MASS REQUIREMENT TO TOW A A330 AT 240 000 kg, AT 1.5% SLOPE, 1 ENGINE AT IDLE AND FOR WET TARMAC CONDITIONS:

- ON THE RIGHT HAND SIDE OF THE GRAPH, CHOOSE THE RELEVANT AIRCRAFT WEIGHT (240 000 kg),
- FROM THIS POINT DRAW A PARALLEL LINE TO THE REQUIRED SLOPE PERCENTAGE (1.5%),
- FROM THE POINT OBTAINED DRAW A STRAIGHT HORIZONTAL LINE UNTIL No. OF ENGINES AT IDLE = 2,
- FROM THIS POINT DRAW A PARALLEL LINE TO THE REQUESTED No. OF ENGINES (1),
- FROM THIS POINT DRAW A STRAIGHT HORIZONTAL LINE TO THE DRAWBAR PULL AXIS,
- THE Y-COORDINATE OBTAINED IS THE NECESSARY DRAWBAR PULL FOR THE TRACTOR (16 000 kg),
- SEARCH THE INTERSECTION WITH THE "WET CONCRETE" LINE.
- THE OBTAINED X-COORDINATE IS THE RECOMMENDED TOTAL TRACTION WHEEL LOAD (xx xxx kg).

NOTE:

USE A TRACTOR WITH A LIMITED DRAWBAR PULL TO PREVENT LOADS ABOVE THE TOW-BAR SHEAR-PIN CAPACITY.

F_AC_050800_1_0020204_01_00

Ground Towing Requirements
 FIGURE-5-8-0-991-002-B01

5-9-0 De-Icing and External Cleaning

****ON A/C A330-200 A330-200F A330-300 A330-800 A330-900**

De-Icing and External Cleaning

1. De-Icing and External Cleaning on Ground

The mobile equipment for aircraft de-icing and external cleaning must be capable of reaching heights up to approximately 17 m (56 ft).

2. De-Icing

AIRCRAFT TYPE	Wing Top Surface (Both Sides)	Wingtip Devices (Both Inside and Outside Surfaces) (Both Sides)	HTP Top Surface (Both Sides)	VTP (Both Sides)
A330-200/-200F	306 m ² (3 294 ft ²)	11 m ² (118 ft ²)	65 m ² (700 ft ²)	106 m ² (1 141 ft ²)
A330-300	306 m ² (3 294 ft ²)	11 m ² (118 ft ²)	65 m ² (700 ft ²)	91 m ² (980 ft ²)
A330-800	306 m ² (3 294 ft ²)	22 m ² (237 ft ²)	65 m ² (700 ft ²)	106 m ² (1 141 ft ²)
A330-900	306 m ² (3 294 ft ²)	22 m ² (237 ft ²)	65 m ² (700 ft ²)	91 m ² (980 ft ²)

AIRCRAFT TYPE	Fuselage Top Surface (Top Third - 120° Arc)	Nacelle and Pylon (Top Third - 120° Arc) (All Engines)	Total De-Iced Area
A330-200/-200F	288 m ² (3 100 ft ²)	46 m ² (495 ft ²)	821 m ² (8 837 ft ²)
A330-300	319 m ² (3 434 ft ²)	46 m ² (495 ft ²)	838 m ² (9 020 ft ²)
A330-800	288 m ² (3 100 ft ²)	49 m ² (527 ft ²)	835 m ² (8 988 ft ²)
A330-900	319 m ² (3 434 ft ²)	49 m ² (527 ft ²)	851 m ² (9 160 ft ²)

NOTE : Dimensions are approximate.

3. External Cleaning

AIRCRAFT TYPE	Wing Top Surface (Both Sides)	Wing Lower Surface (Including Flap Track Fairing) (Both Sides)	Wingtip Devices (Both Inside and Outside Surfaces) (Both Sides)	HTP Top Surface (Both Sides)	HTP Lower Surface (Both Sides)
A330-200/-200F	306 m ² (3 294 ft ²)	345 m ² (3 714 ft ²)	11 m ² (118 ft ²)	65 m ² (700 ft ²)	65 m ² (700 ft ²)
A330-300	306 m ² (3 294 ft ²)	345 m ² (3 714 ft ²)	11 m ² (118 ft ²)	65 m ² (700 ft ²)	65 m ² (700 ft ²)
A330-800	306 m ² (3 294 ft ²)	345 m ² (3 714 ft ²)	22 m ² (237 ft ²)	65 m ² (700 ft ²)	65 m ² (700 ft ²)
A330-900	306 m ² (3 294 ft ²)	345 m ² (3 714 ft ²)	22 m ² (237 ft ²)	65 m ² (700 ft ²)	65 m ² (700 ft ²)

AIRCRAFT TYPE	VTP (Both Sides)	Fuselage and Belly Fairing	Nacelle and Pylon (All Engines)	Total Cleaned Area
A330-200/-200F	106 m ² (1 141 ft ²)	877 m ² (9 440 ft ²)	154 m ² (1 658 ft ²)	1 940 m ² (20 882 ft ²)
A330-300	91 m ² (980 ft ²)	971 m ² (10 452 ft ²)	154 m ² (1 658 ft ²)	2 016 m ² (21 700 ft ²)
A330-800	106 m ² (1 141 ft ²)	877 m ² (9 440 ft ²)	213 m ² (2 293 ft ²)	2 011 m ² (21 646 ft ²)
A330-900	91 m ² (980 ft ²)	971 m ² (10 452 ft ²)	213 m ² (2 293 ft ²)	2 087 m ² (22 464 ft ²)

NOTE : Dimensions are approximate.

OPERATING CONDITIONS**6-1-0 Engine Exhaust Velocities and Temperatures******ON A/C A330-200 A330-200F A330-300 A330-800 A330-900**Engine Exhaust Velocities and Temperatures

1. General

This section shows the estimated engine exhaust efflux velocities and temperatures contours for Ground Idle, Breakaway and Maximum Takeoff conditions.



6-1-1 Engine Exhaust Velocities Contours - Ground Idle Power

****ON A/C A330-200 A330-200F A330-300 A330-800 A330-900**

Engine Exhaust Velocities Contours - Ground Idle Power

1. This section gives engine exhaust velocities contours at ground idle power.

**ON A/C A330-200 A330-200F A330-300

NOTE : ALL VELOCITY VALUES ARE IN STATUTE MILES PER HOUR.
GROUND IDLE POWER, SEA LEVEL STATIC, ZERO WIND
STANDARD DAY, ZERO RAMP GRADIENT ENGINE TYPE.

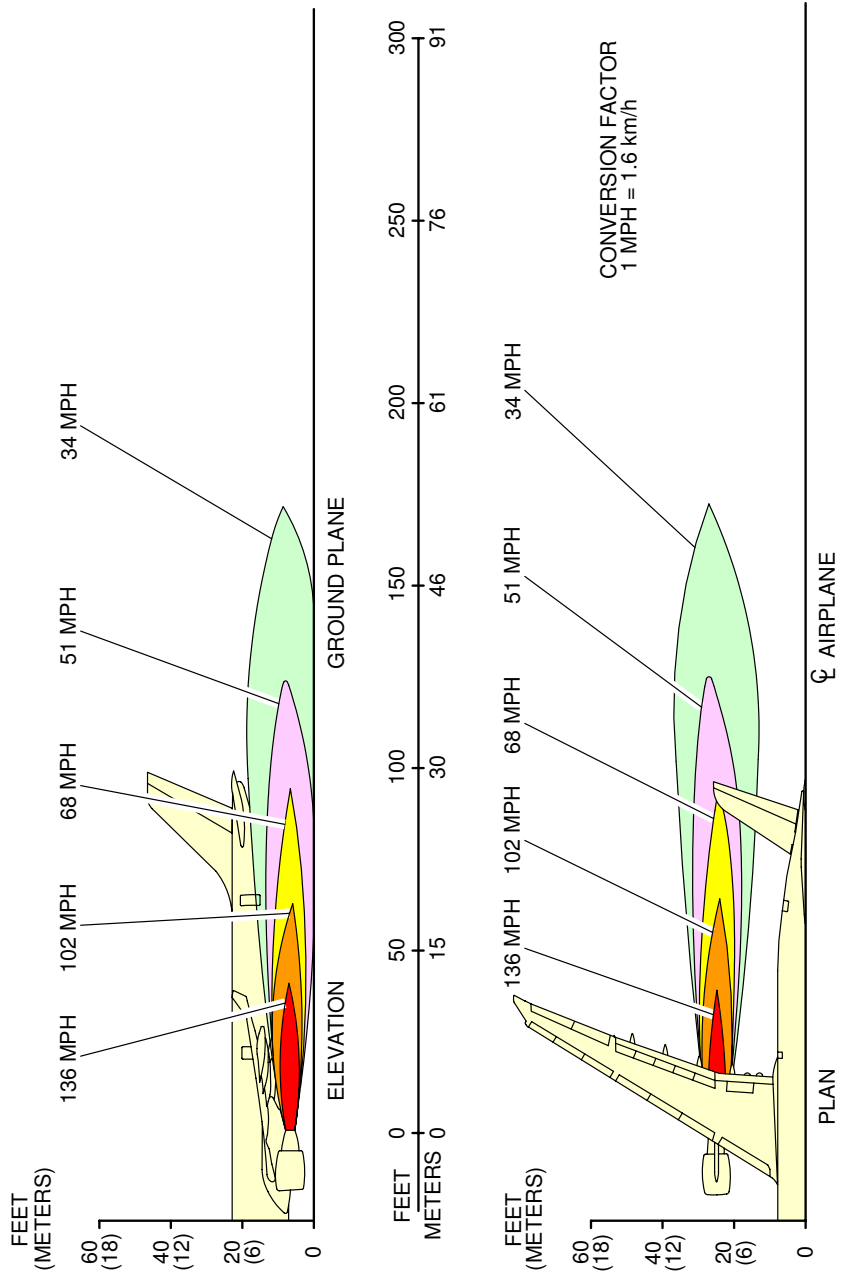

G-00226 (0000)

F_AC_060101_1_0010101_01_00

Engine Exhaust Velocities
Ground Idle Power - PW 4000 series engine
FIGURE-6-1-1-991-001-A01

****ON A/C A330-200 A330-200F A330-300**

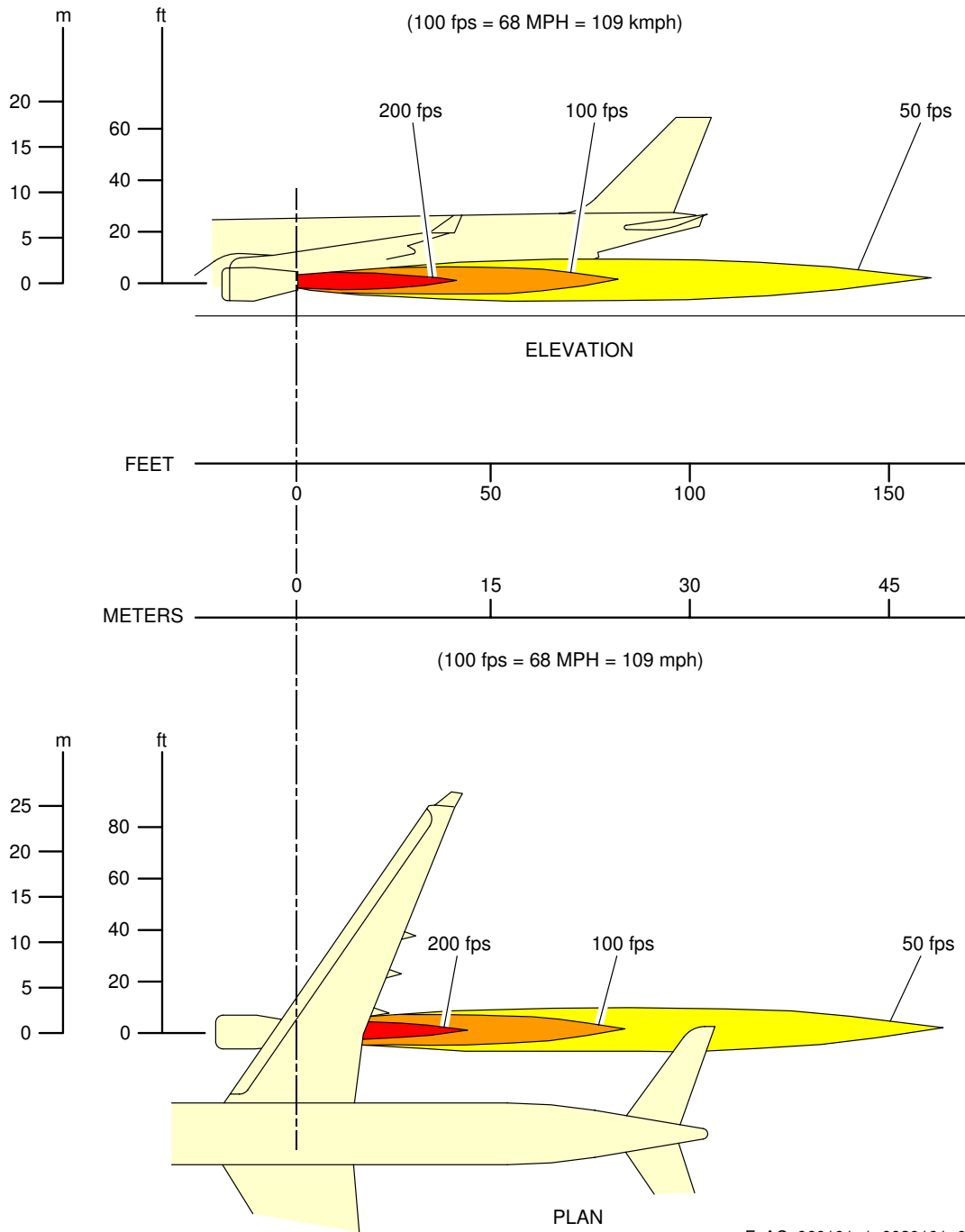

F_AC_060101_1_0020101_01_00

Engine Exhaust Velocities
 Ground Idle Power - RR Trent 700 series engine
 FIGURE-6-1-1-991-002-A01

****ON A/C A330-200 A330-300**

(100 fps = 68 MPH = 109 kmph)

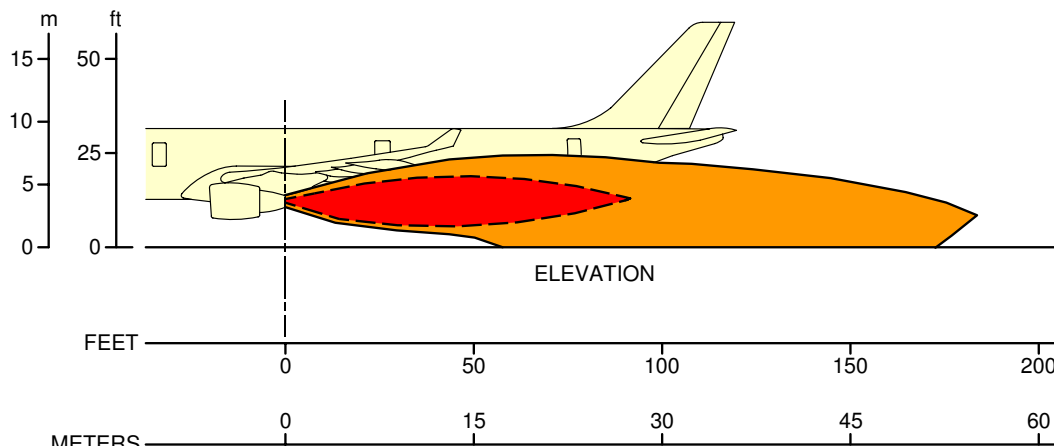

(100 fps = 68 MPH = 109 kmph)

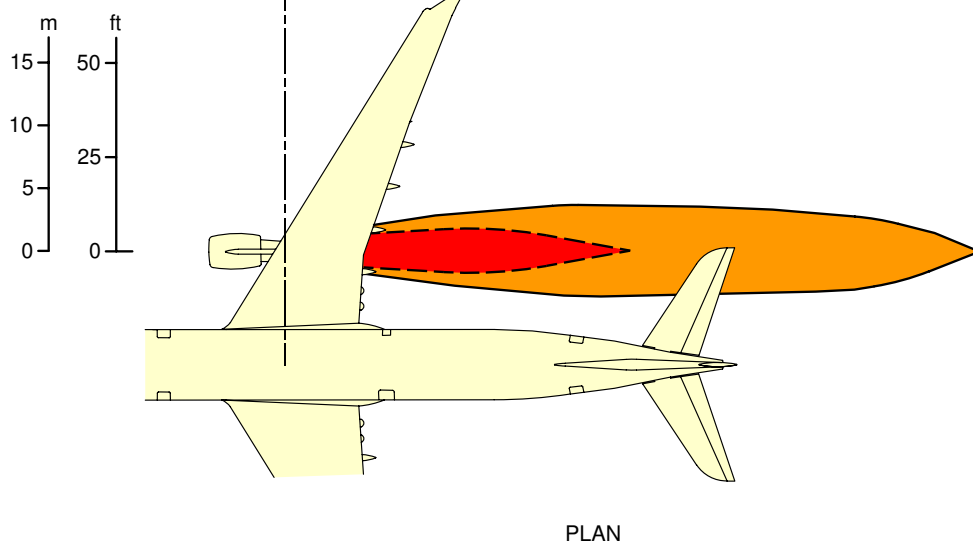

—	V=51.3 ft/s	35 MPH	56 km/h
- - -	V=95.3	65	105

F_AC_060101_1_0030101_01_01

Engine Exhaust Velocities
 Ground Idle Power - GE CF6-80E1 series engine
 FIGURE-6-1-1-991-003-A01

**ON A/C A330-800 A330-900

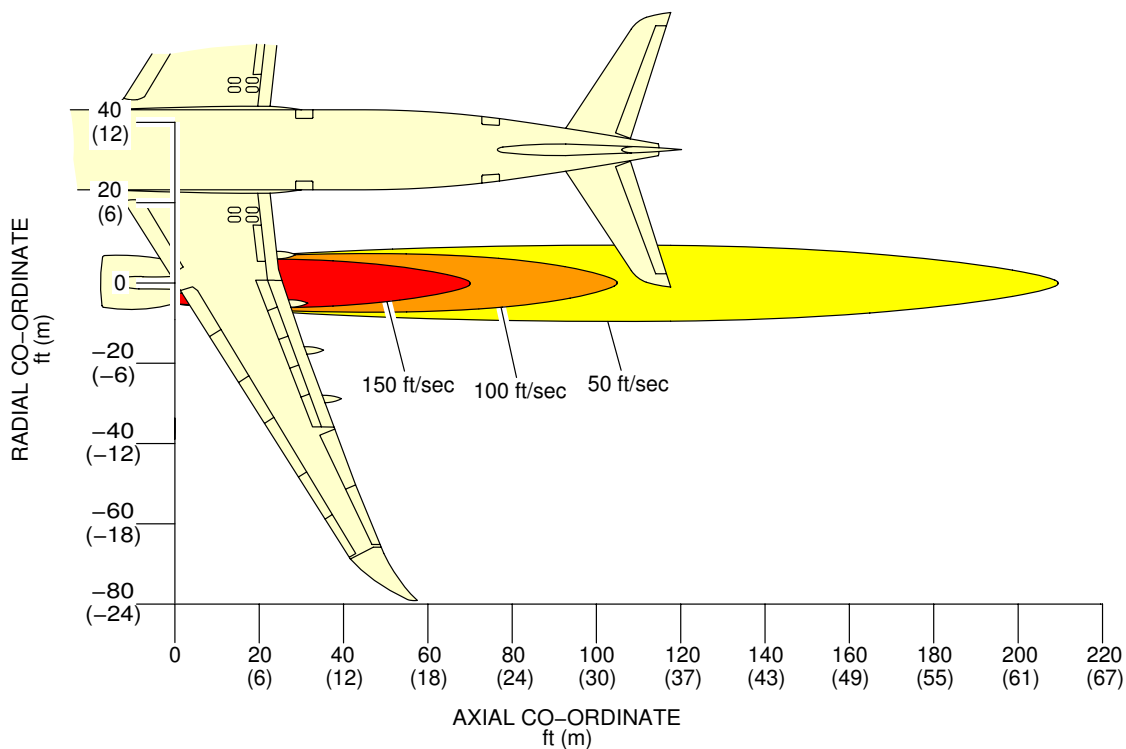
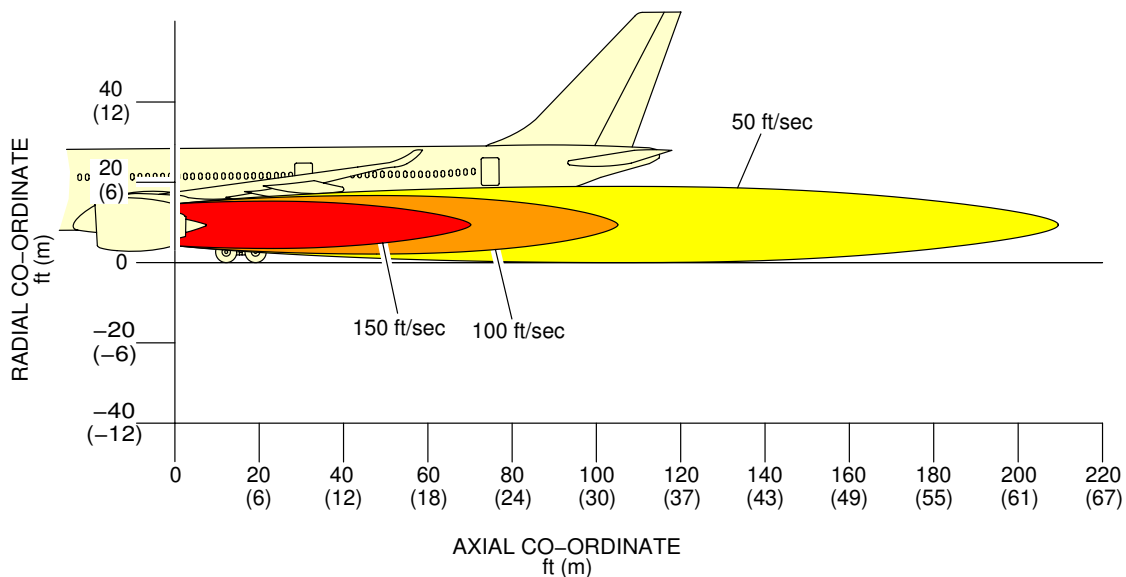

F_AC_060101_1_0060101_01_00

Engine Exhaust Velocities
 Ground Idle Power - RR Trent 7000 series engine
 FIGURE-6-1-1-991-006-A01



6-1-2 Engine Exhaust Temperatures Contours - Ground Idle Power

****ON A/C A330-200 A330-200F A330-300 A330-800 A330-900**

Engine Exhaust Temperatures Contours - Ground Idle Power

1. This section gives engine exhaust temperatures contours at ground idle power.

****ON A/C A330-200 A330-200F A330-300**

NOTE : TEMPERATURES ARE IN DEGREES FAHRENHEIT (DEGREES C)
GROUND IDLE POWER - SEA LEVEL STATIC, ZERO WIND,
STANDARD DAY, ZERO RAMP GRADIENT ENGINE TYPE.

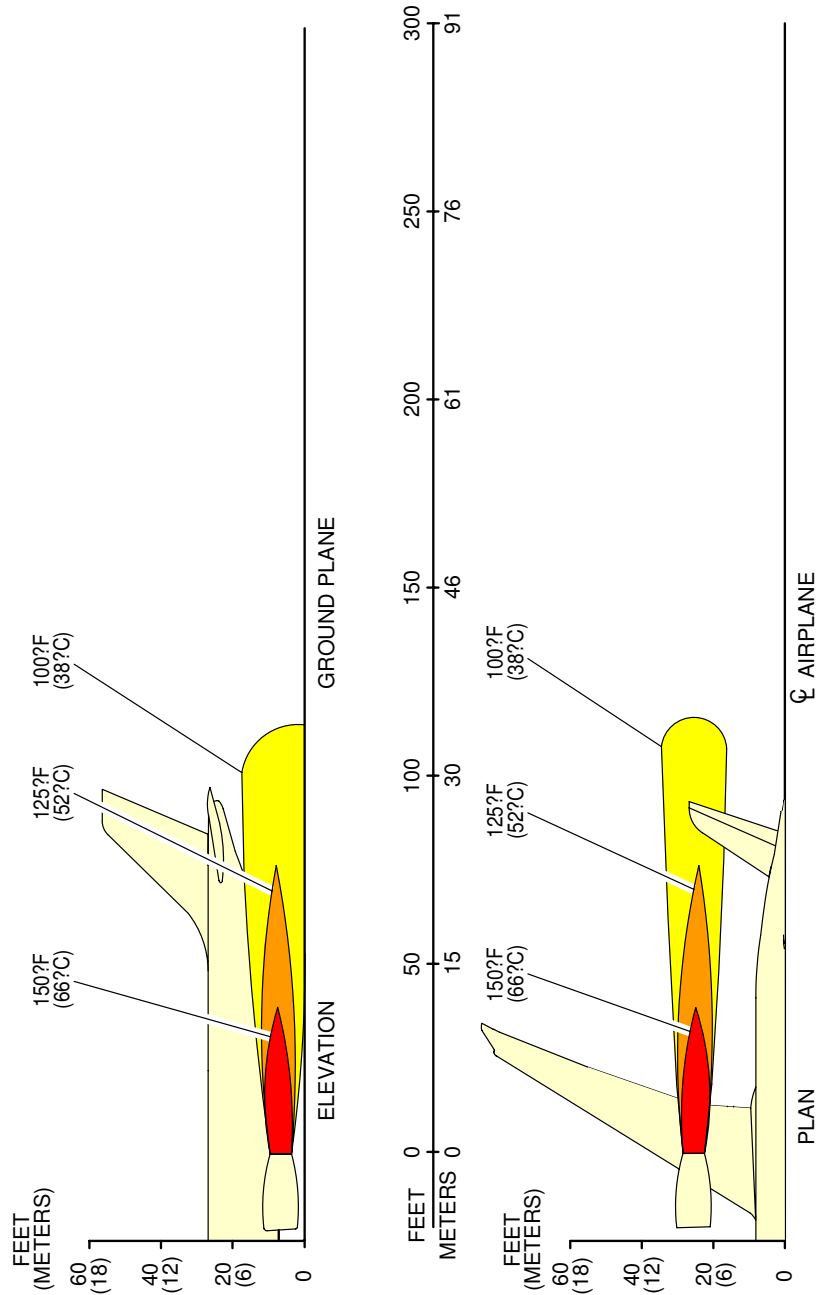

F_AC_060102_1_0010101_01_00

Engine Exhaust Temperatures
Ground Idle Power - PW 4000 series engine
FIGURE-6-1-2-991-001-A01

G-00229 (1294)

**ON A/C A330-200 A330-200F A330-300

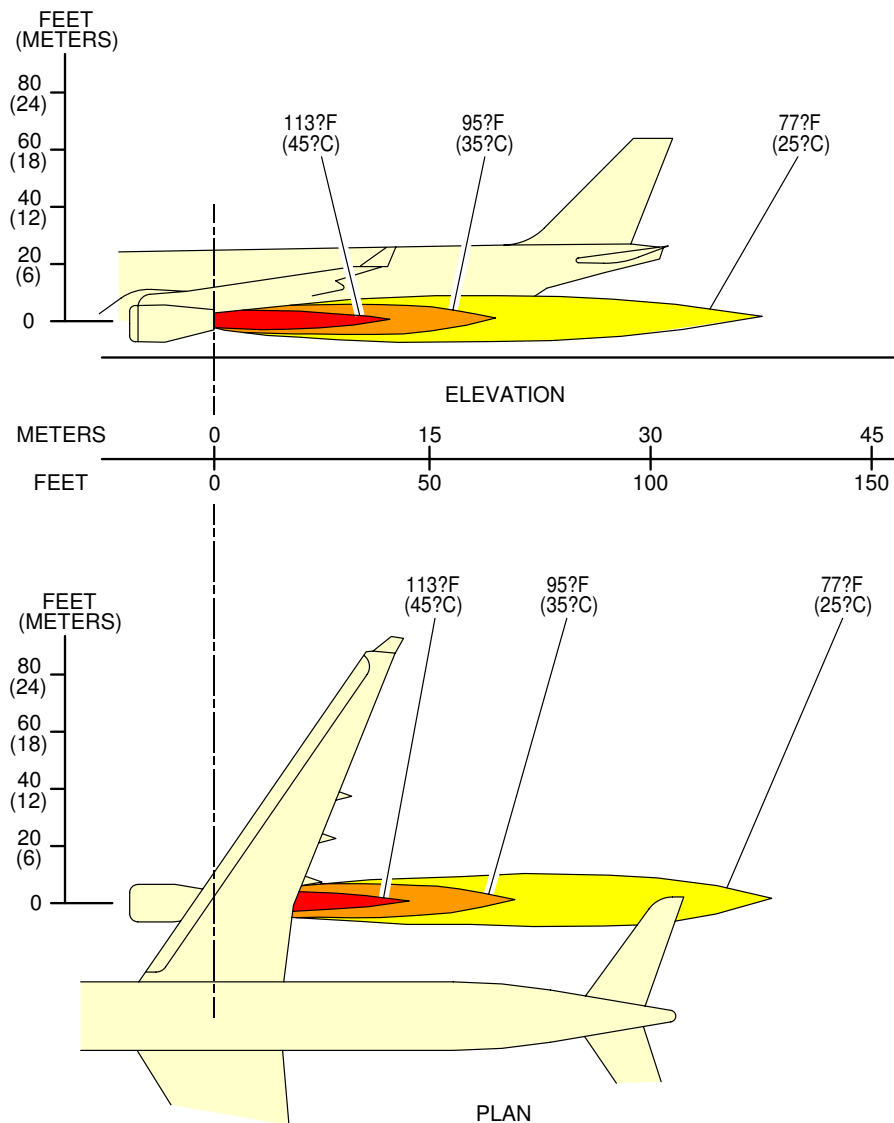

F_AC_060102_1_0020101_01_00

Engine Exhaust Temperatures
Ground Idle Power - RR Trent 700 series engine
FIGURE-6-1-2-991-002-A01

**ON A/C A330-200 A330-300

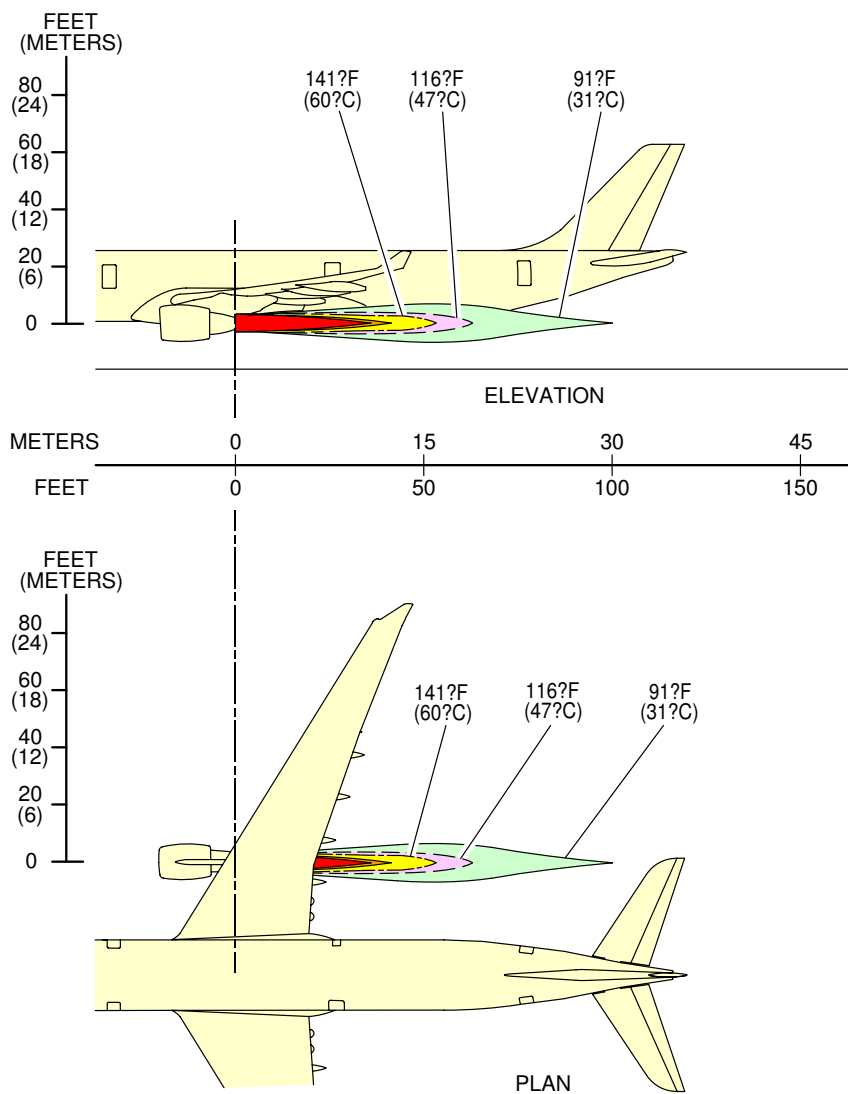

F_AC_060102_1_0030101_01_01

Engine Exhaust Temperatures
Ground Idle Power - GE CF6-80E1 series engine
FIGURE-6-1-2-991-003-A01

**ON A/C A330-800 A330-900

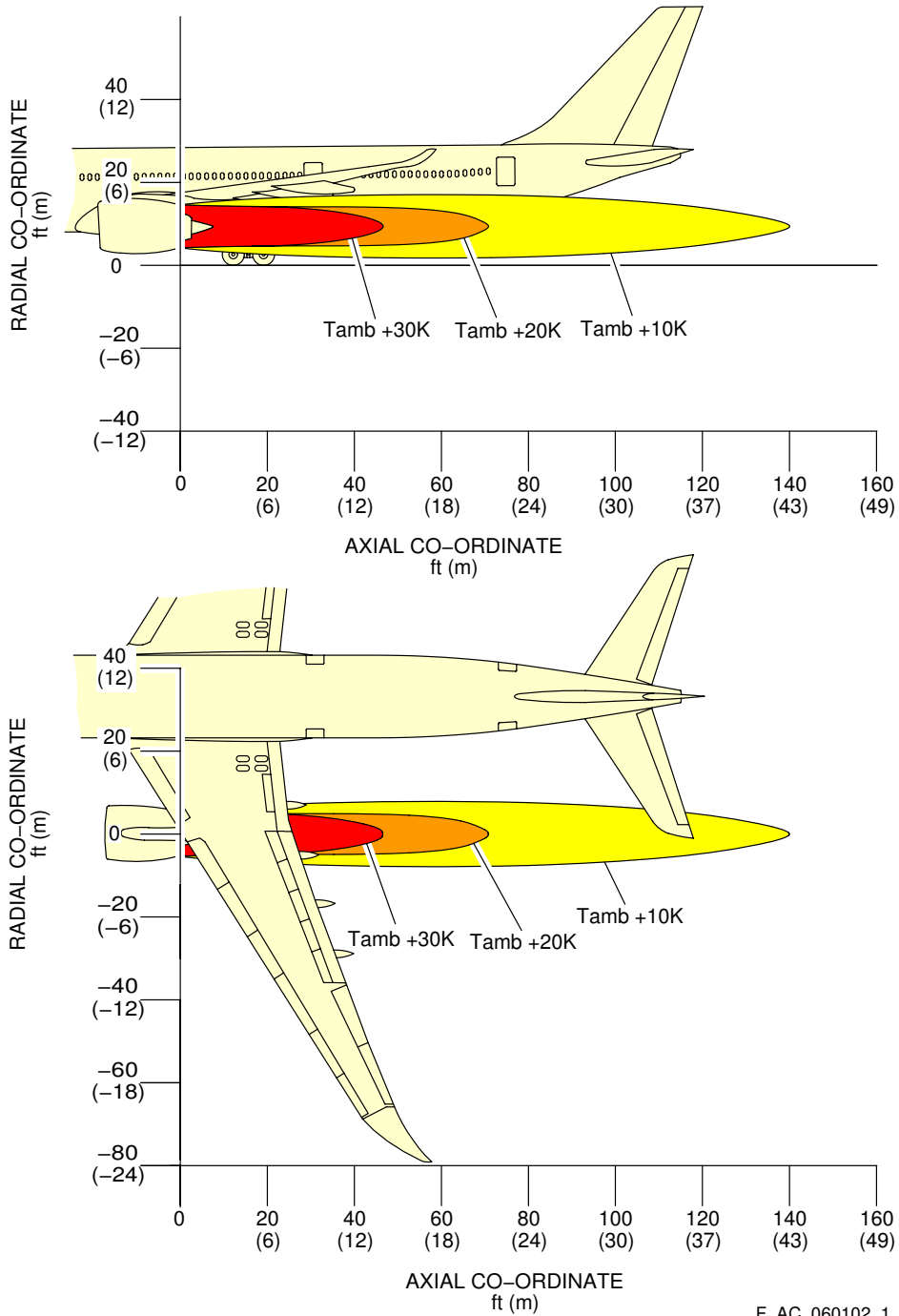

F_AC_060102_1_0060101_01_00

Engine Exhaust Temperatures
Ground Idle Power - RR Trent 7000 series engine
FIGURE-6-1-2-991-006-A01



6-1-3 Engine Exhaust Velocities Contours - Breakaway Power

****ON A/C A330-200 A330-200F A330-300 A330-800 A330-900**

Engine Exhaust Velocities Contours - Breakaway Power

1. This section gives engine exhaust velocities contours at breakaway power.

****ON A/C A330-200 A330-200F A330-300**

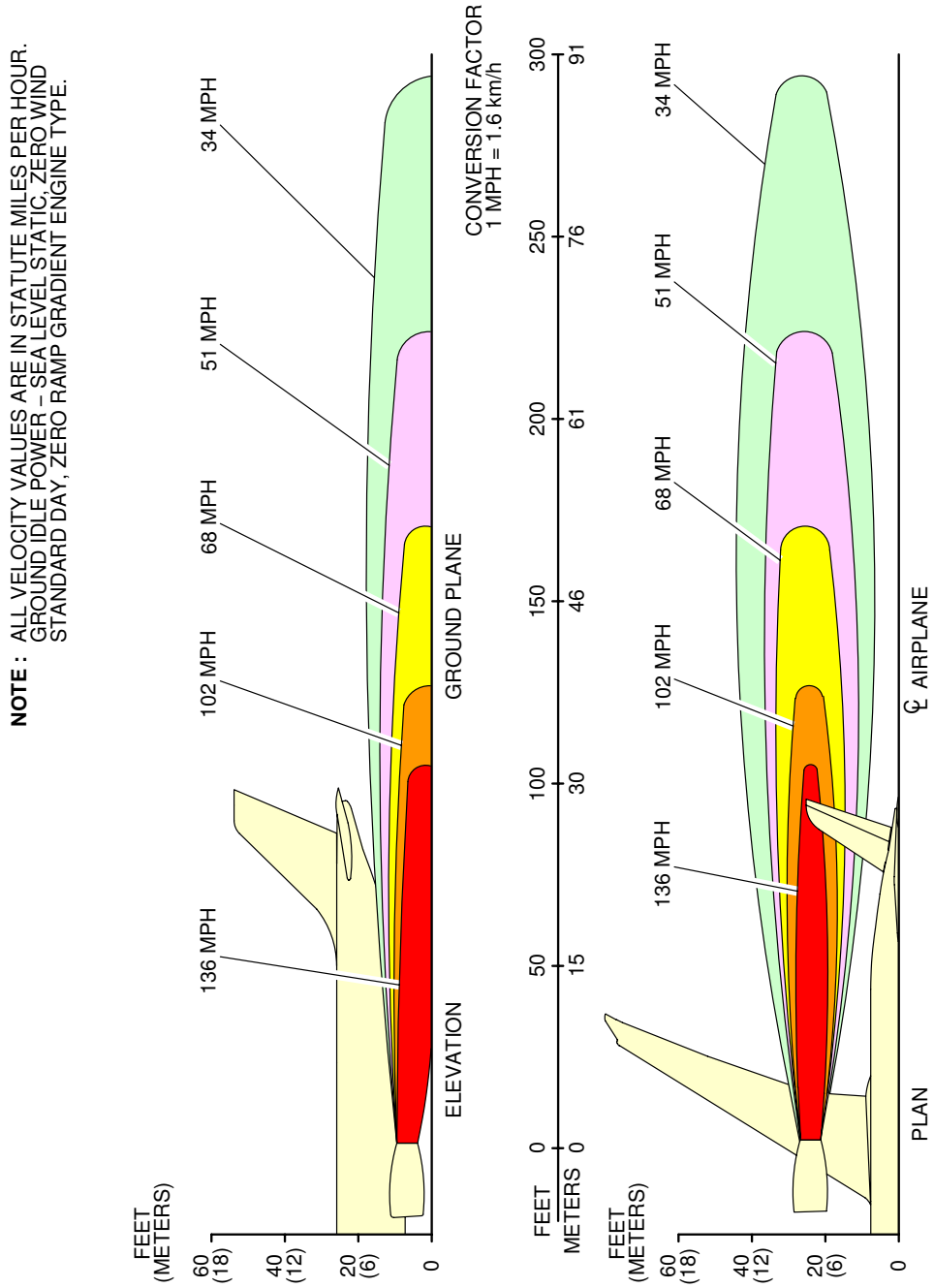

G-03247 (0000)

F_AC_060103_1_0010101_01_00

Engine Exhaust Velocities
Breakaway Power - PW 4000 series engine
FIGURE-6-1-3-991-001-A01

****ON A/C A330-200 A330-200F A330-300**

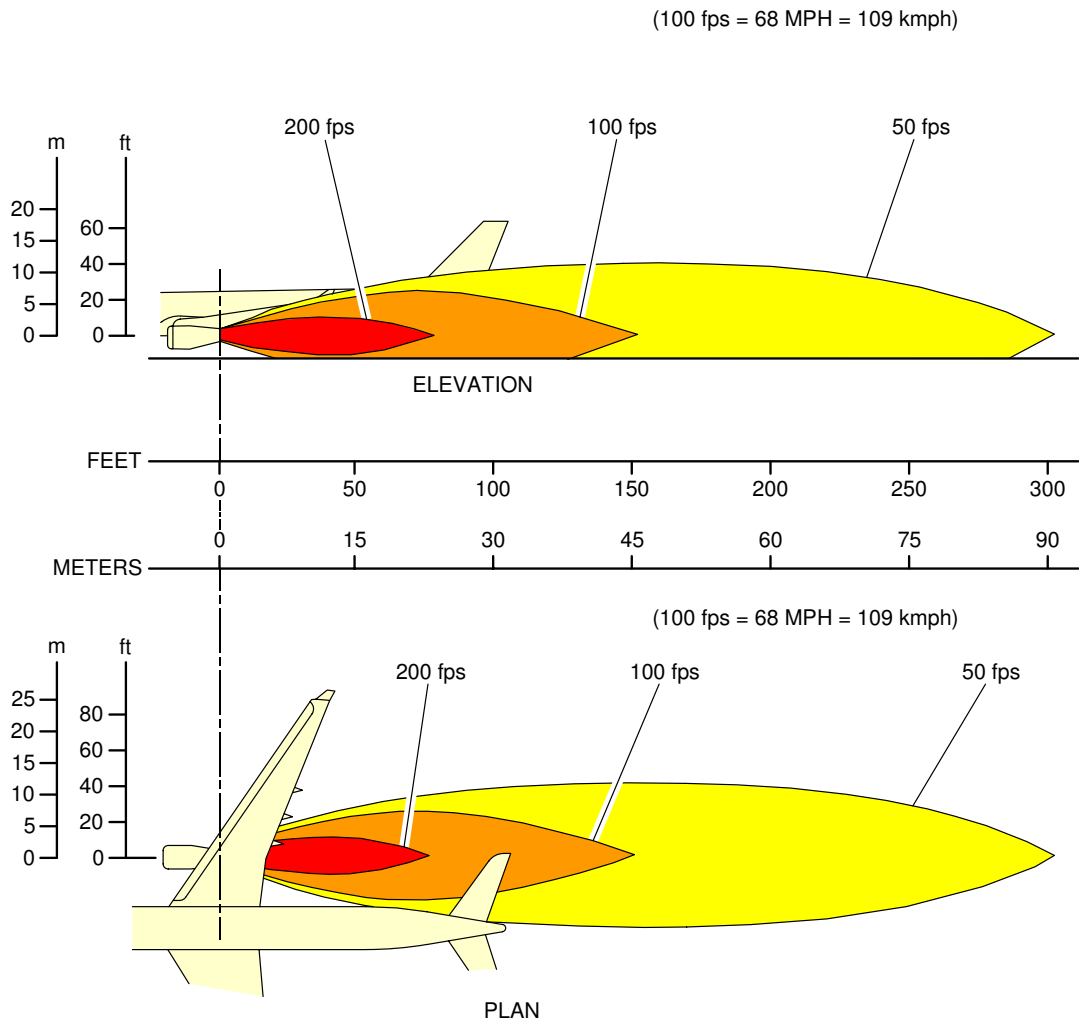

F_AC_060103_1_0020101_01_00

Engine Exhaust Velocities
Breakaway Power - RR Trent 700 series engine
FIGURE-6-1-3-991-002-A01

**ON A/C A330-200 A330-300

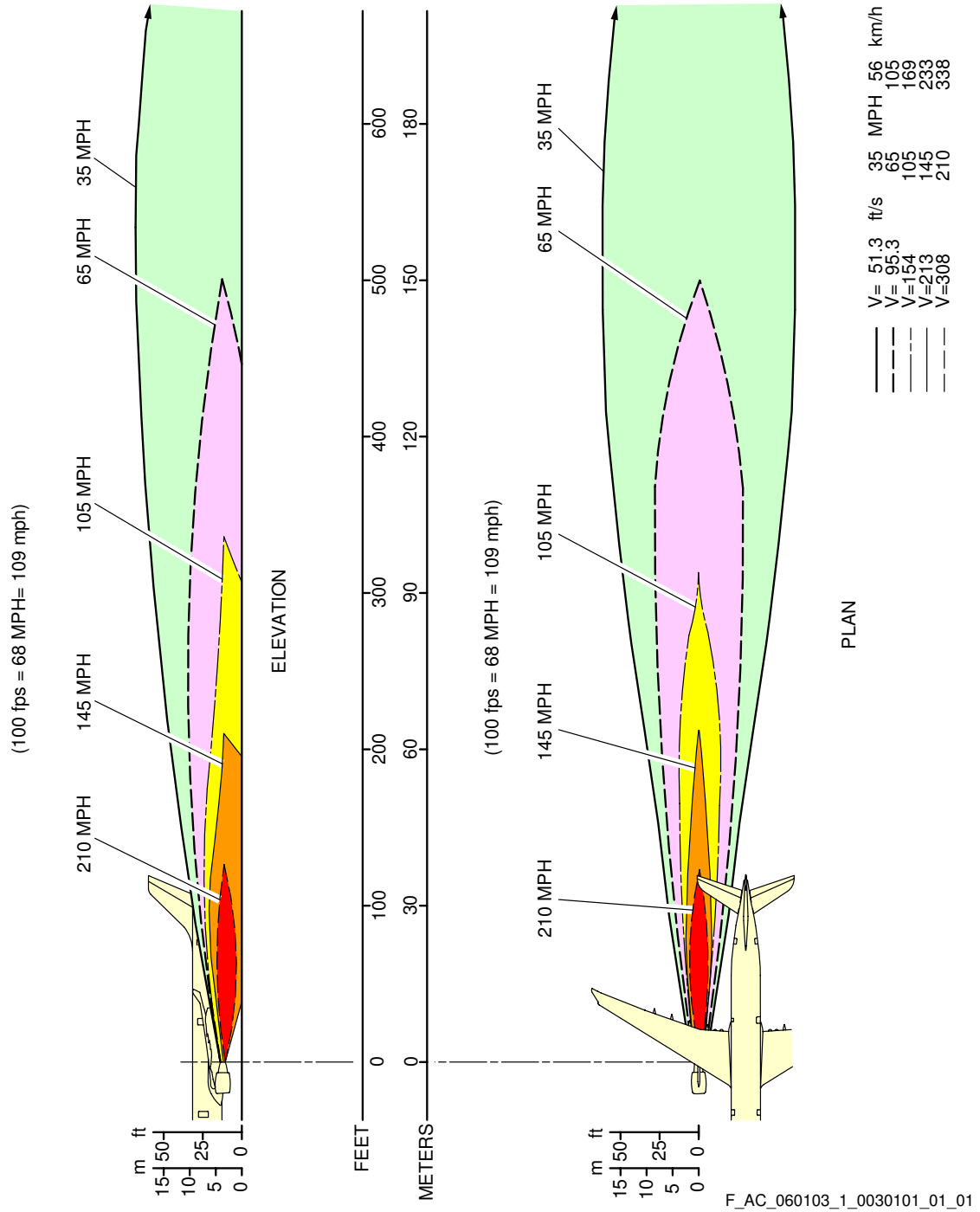

Engine Exhaust Velocities
 Breakaway Power - GE CF6-80E1 series engine
 FIGURE-6-1-3-991-003-A01

**ON A/C A330-800 A330-900

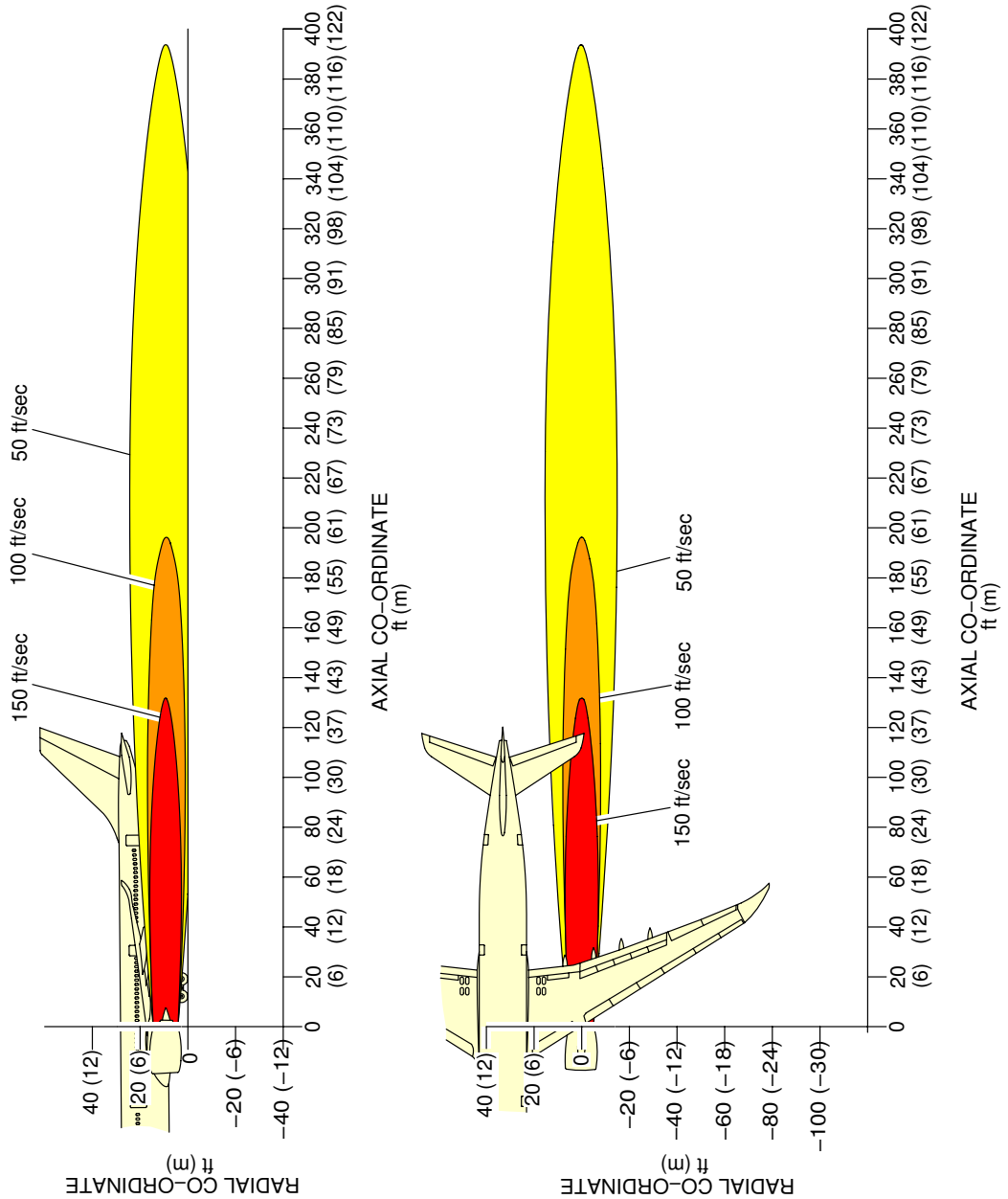

F_AC_060103_1_0070101_01_00

Engine Exhaust Velocities
 Breakaway Power (14% MTO Thrust) - RR Trent 7000 series engine
 FIGURE-6-1-3-991-007-A01

****ON A/C A330-800 A330-900**

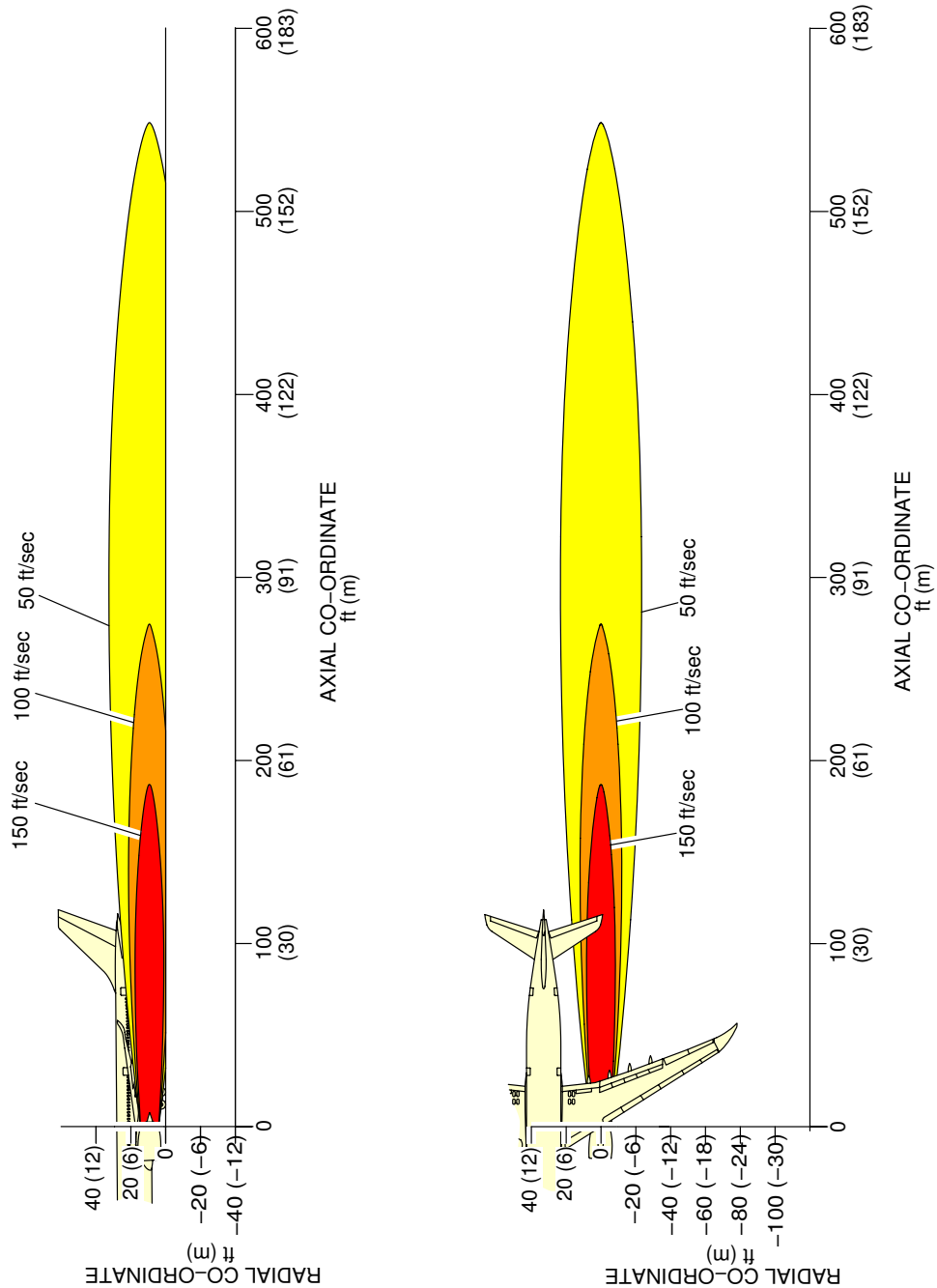

F_AC_060103_1_0080101_01_00

Engine Exhaust Velocities
 Breakaway Power (28% MTO Thrust) - RR Trent 7000 series engine
 FIGURE-6-1-3-991-008-A01



6-1-4 Engine Exhaust Temperatures Contours - Breakaway Power

****ON A/C A330-200 A330-200F A330-300 A330-800 A330-900**

Engine Exhaust Temperatures Contours - Breakaway Power

1. This section gives engine exhaust temperatures contours at breakaway power.

****ON A/C A330-200 A330-200F A330-300**

NOTE : TEMPERATURES ARE IN DEGREES FAHRENHEIT (DEGREES C)
 GROUND IDLE POWER - SEA LEVEL STATIC, ZERO WIND,
 STANDARD DAY, ZERO RAMP GRADIENT ENGINE TYPE.

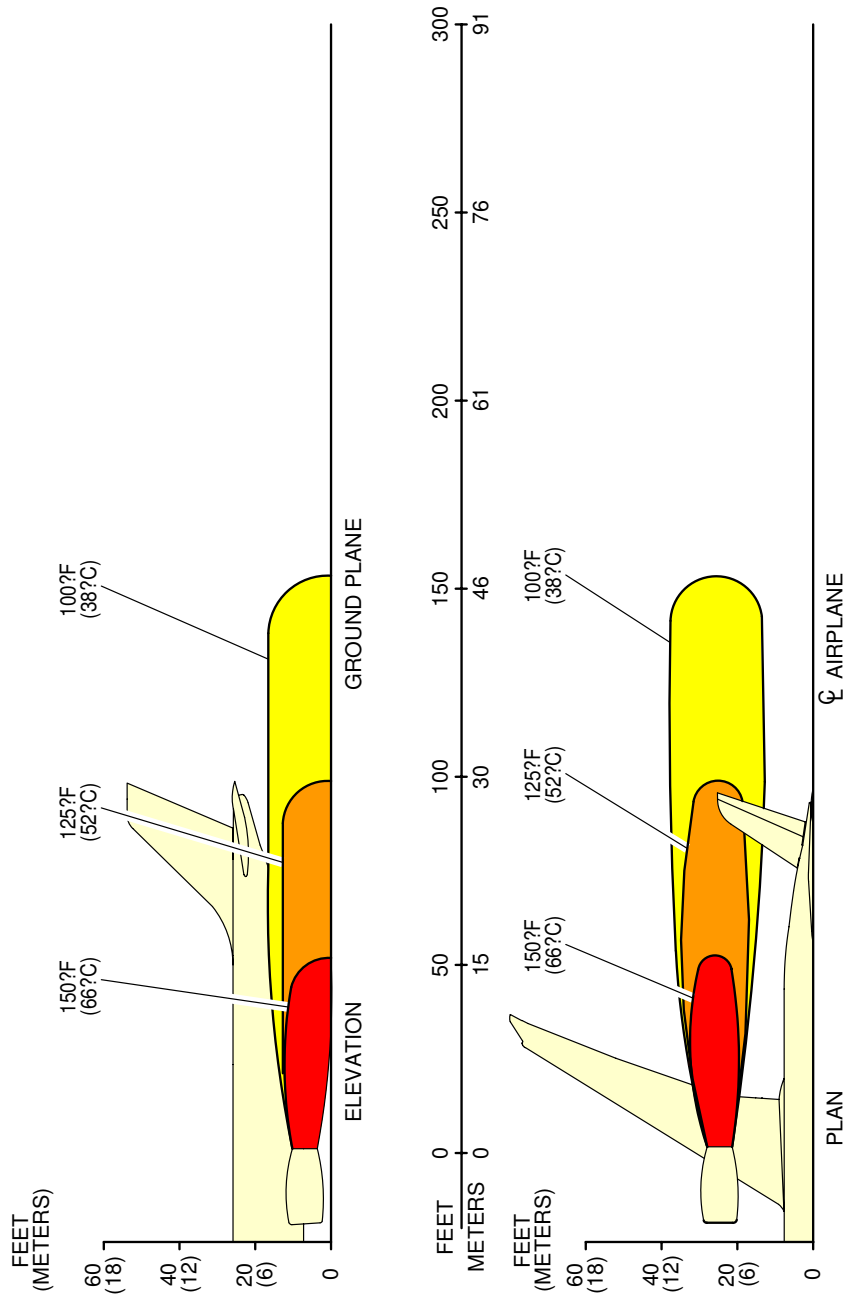

G-03246 (0000)

F_AC_060104_1_0010101_01_00

Engine Exhaust Temperatures
 Breakaway Power - PW 4000 series engine
 FIGURE-6-1-4-991-001-A01

**ON A/C A330-200 A330-200F A330-300

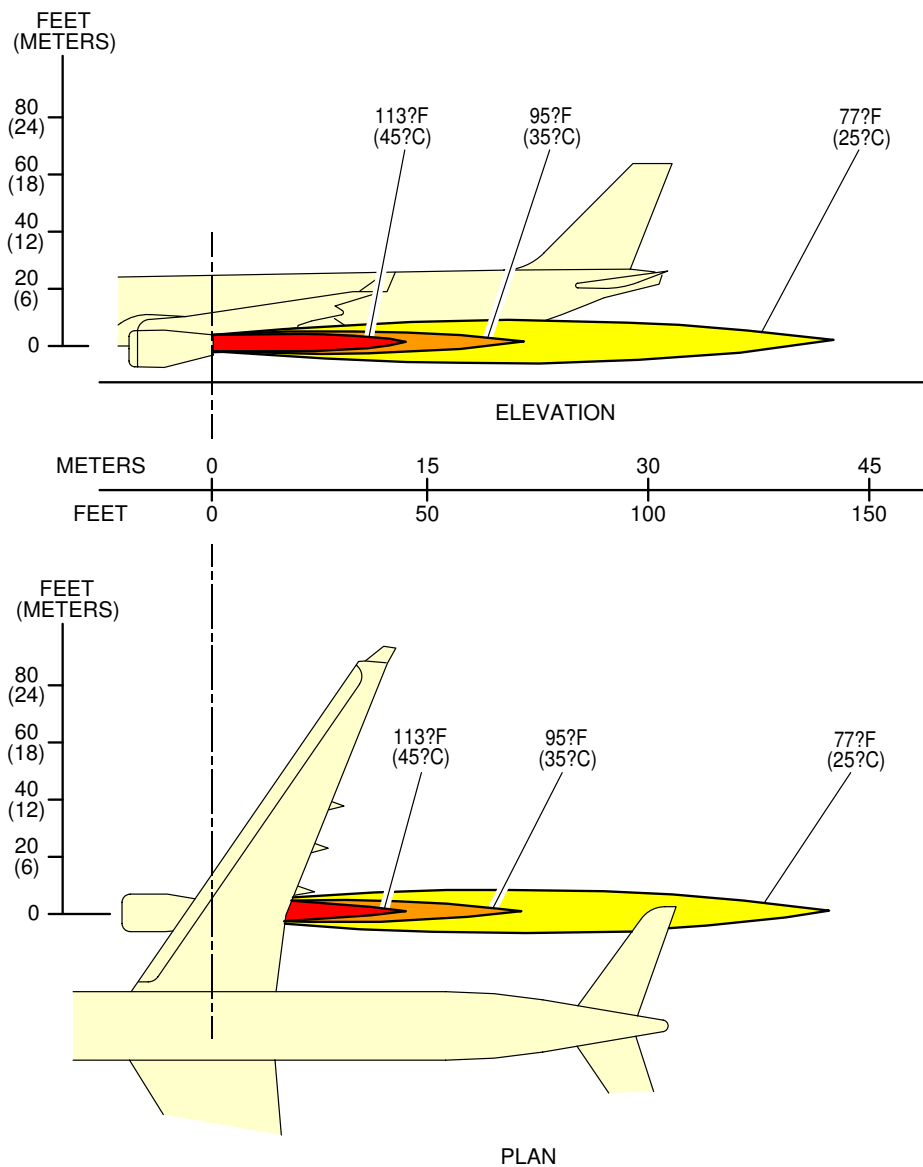

F_AC_060104_1_0020101_01_00

Engine Exhaust Temperatures
Breakaway Power - RR Trent 700 series engine
FIGURE-6-1-4-991-002-A01

**ON A/C A330-200 A330-300

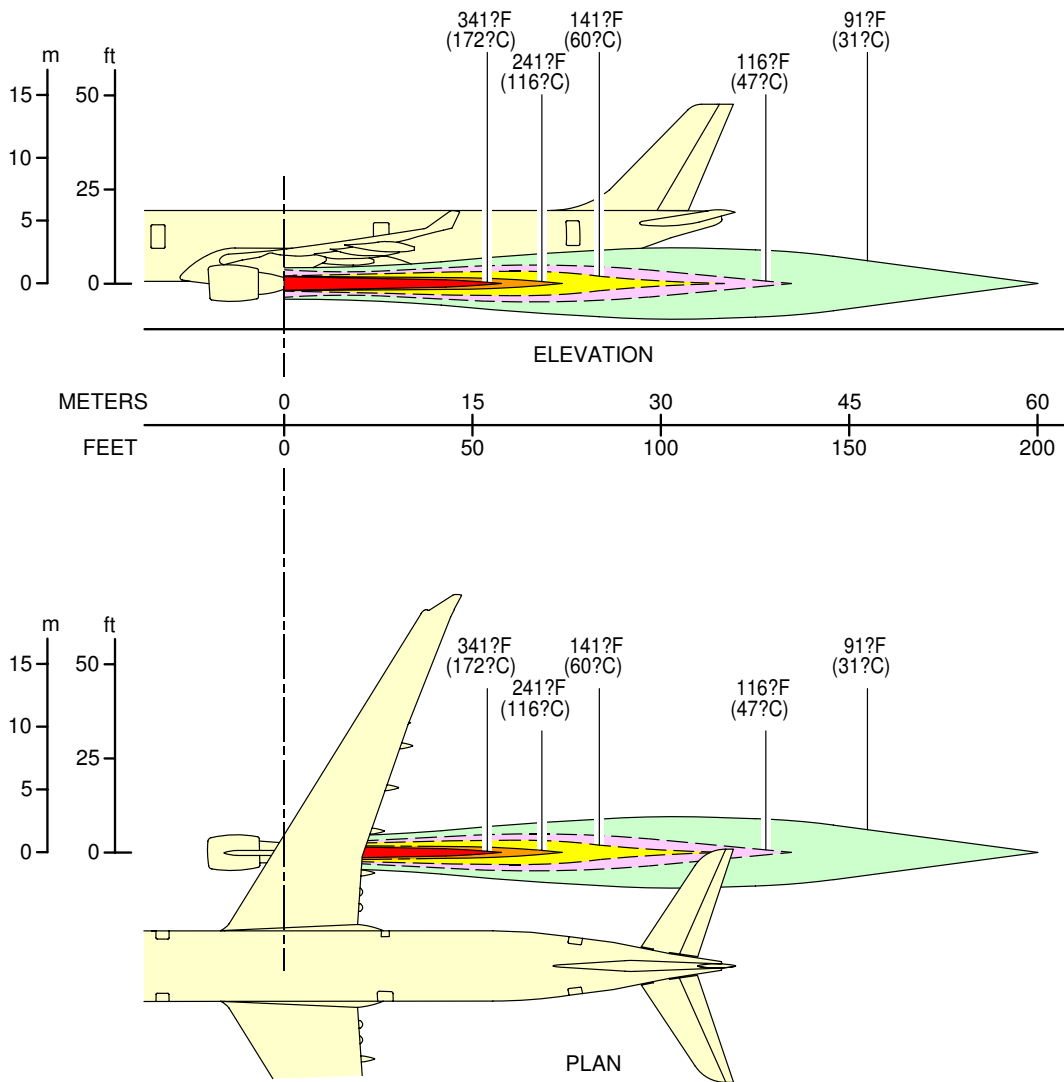

F_AC_060104_1_0030101_01_01

Engine Exhaust Temperatures
Breakaway Power - GE CF6-80E1 series engine
FIGURE-6-1-4-991-003-A01

****ON A/C A330-800 A330-900**

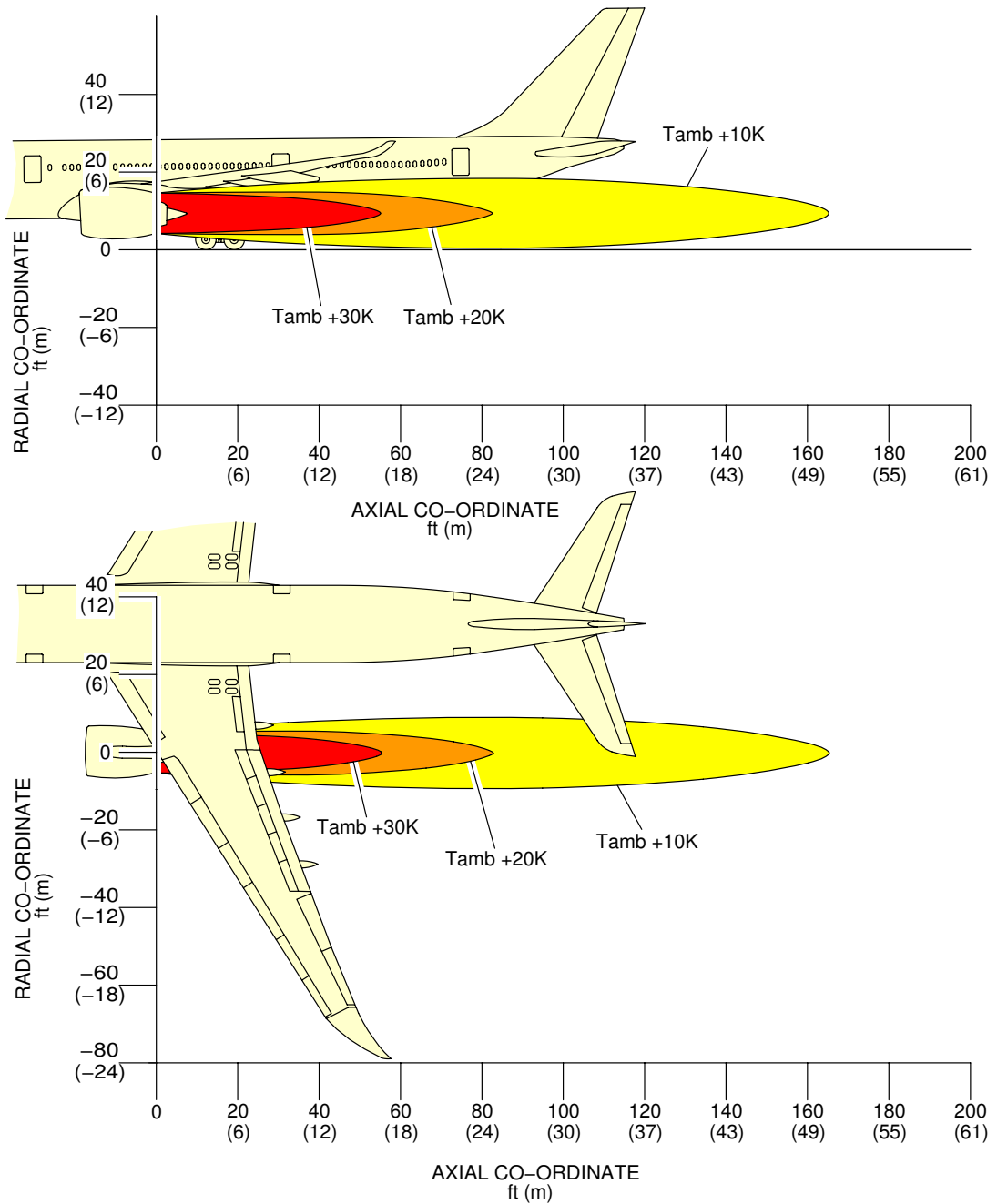

F_AC_060104_1_0070101_01_00

Engine Exhaust Temperatures
 Breakaway Power (14% MTO Thrust) - RR Trent 7000 series engine
 FIGURE-6-1-4-991-007-A01

****ON A/C A330-800 A330-900**

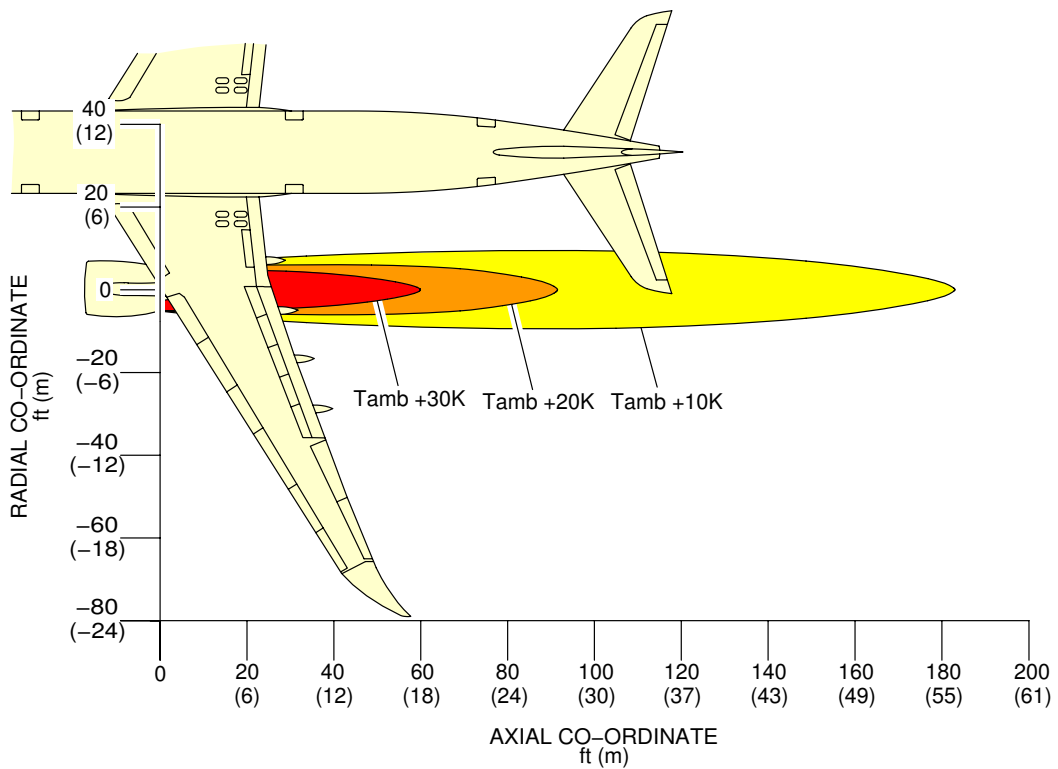
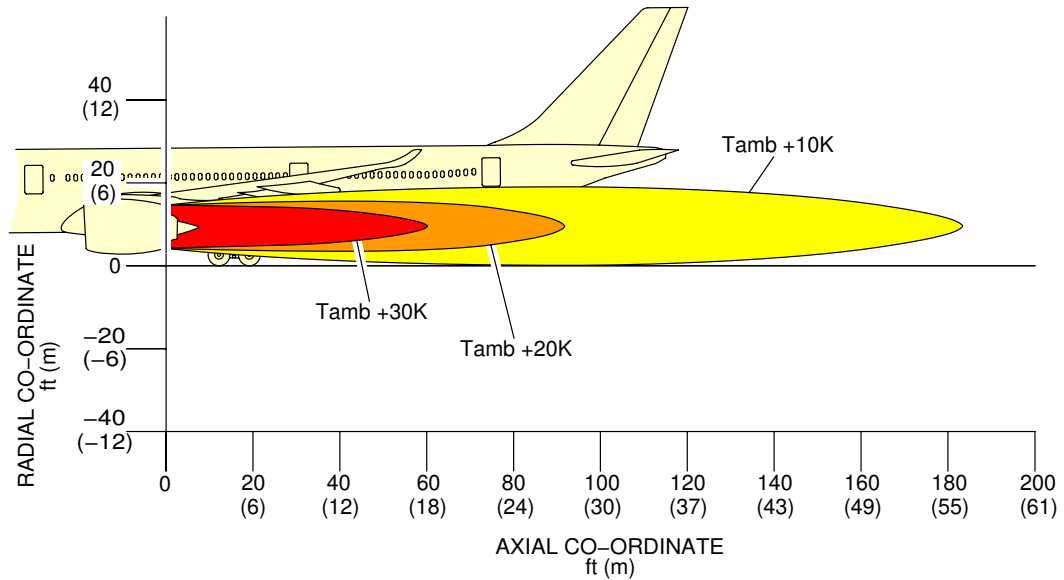

F_AC_060104_1_0080101_01_00

Engine Exhaust Temperatures
 Breakaway Power (28% MTO Thrust) - RR Trent 7000 series engine
 FIGURE-6-1-4-991-008-A01



6-1-5 Engine Exhaust Velocities Contours - Takeoff Power

****ON A/C A330-200 A330-200F A330-300 A330-800 A330-900**

Engine Exhaust Velocities Contours - Takeoff Power

1. This section gives engine exhaust velocities contours at takeoff power.

****ON A/C A330-200 A330-200F A330-300**

NOTE : ALL VELOCITY VALUES ARE IN STATUTE MILES PER HOUR.
TAKEOFF POWER - SEA LEVEL STATIC, ZERO WIND
STANDARD DAY, ZERO RAMP GRADIENT ENGINE TYPE.

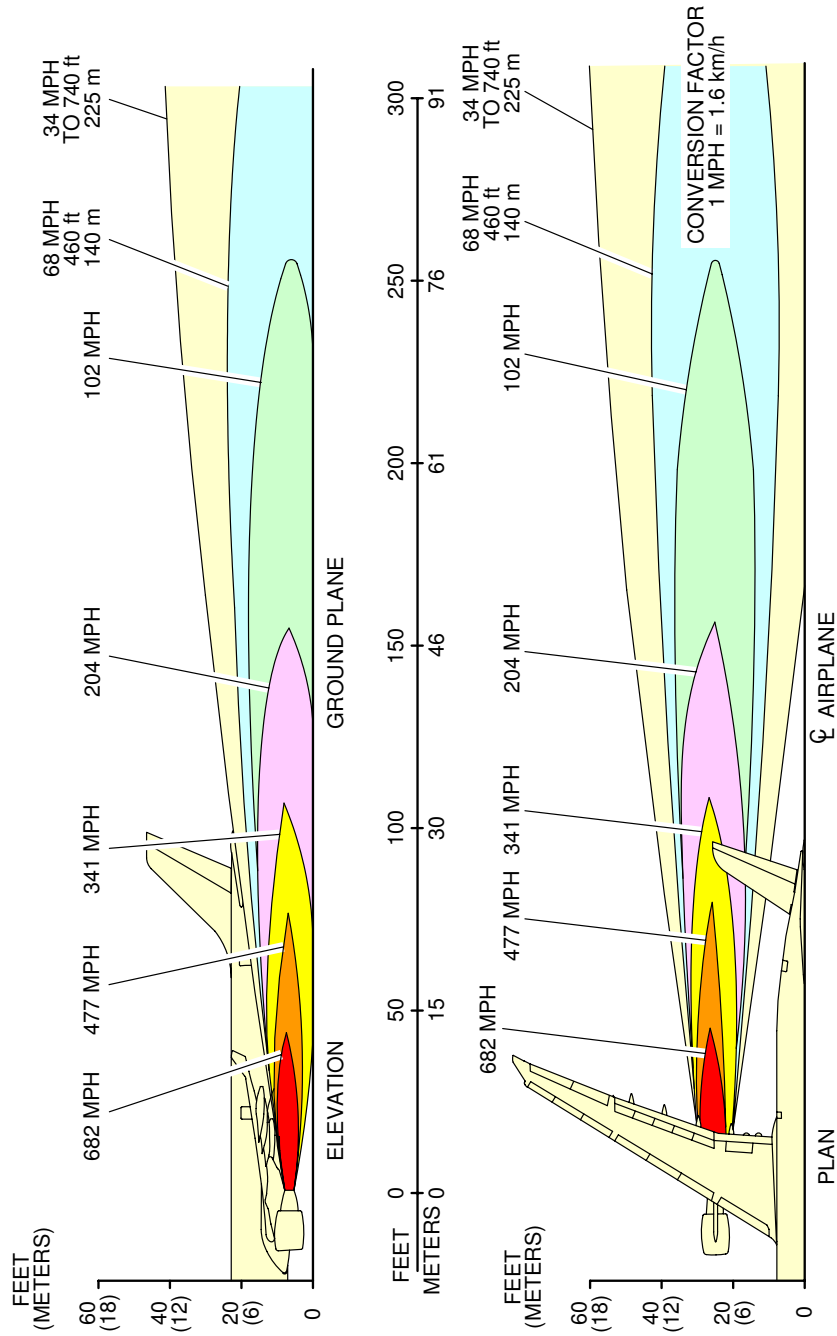

G-00228 (1294)

F_AC_060105_1_0010101_01_00

Engine Exhaust Velocities
Takeoff Power - PW 4000 series engine
FIGURE-6-1-5-991-001-A01

**ON A/C A330-200 A330-200F A330-300

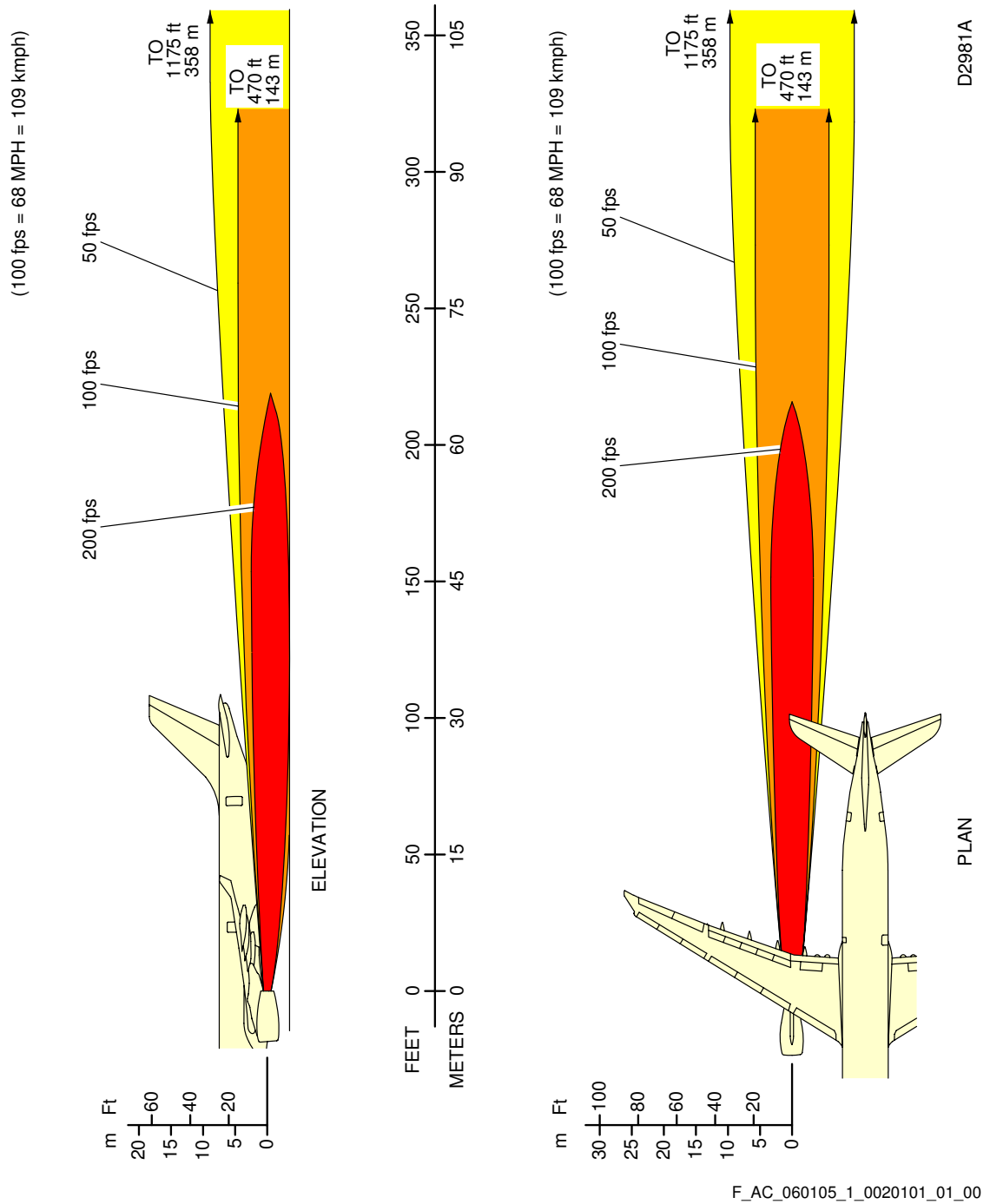

Engine Exhaust Velocities
Takeoff Power - RR Trent 700 series engine
FIGURE-6-1-5-991-002-A01

D2981A

**ON A/C A330-200 A330-300

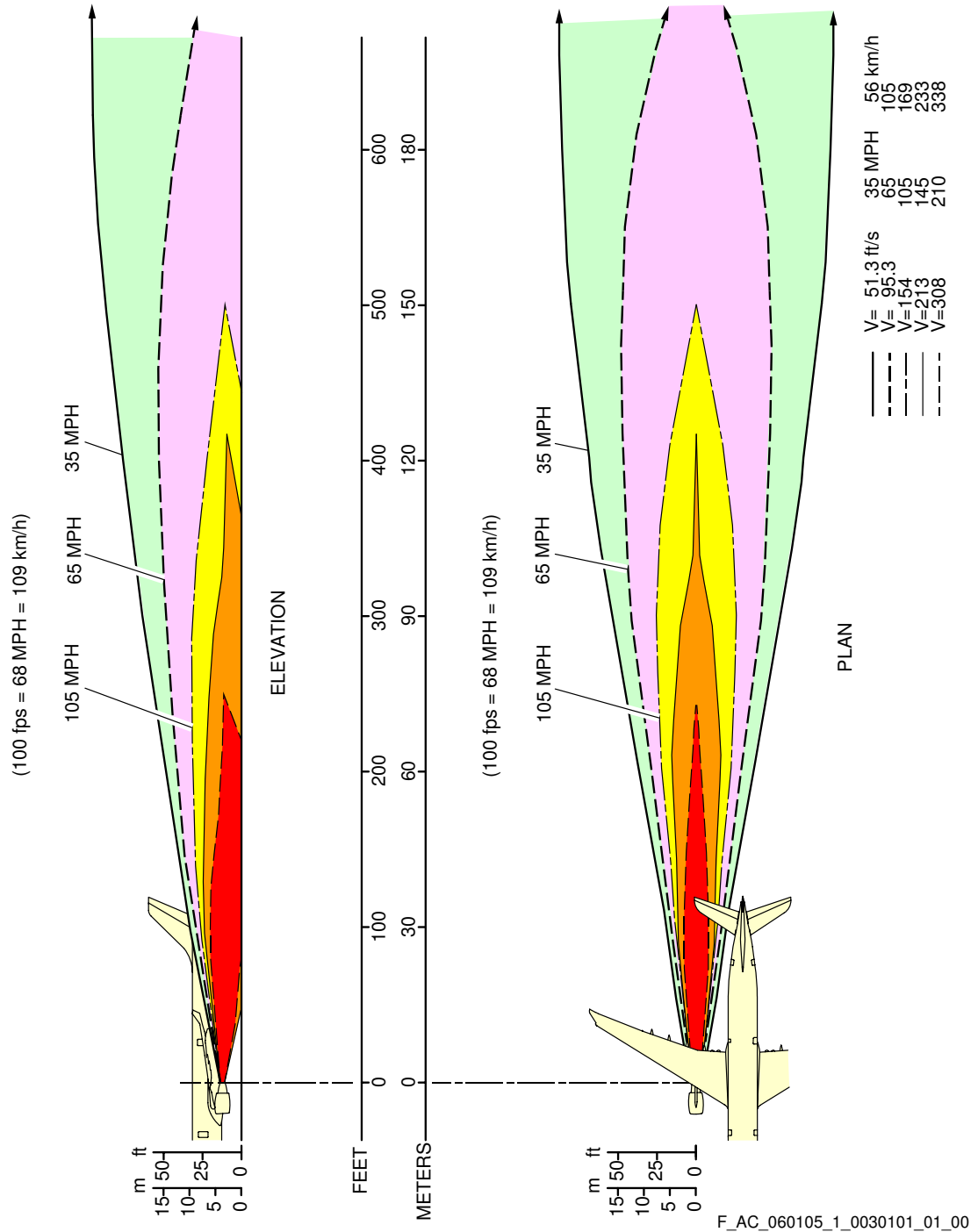

Engine Exhaust Velocities
Takeoff Power - GE CF6-80E1 series engine
FIGURE-6-1-5-991-003-A01

**ON A/C A330-800 A330-900

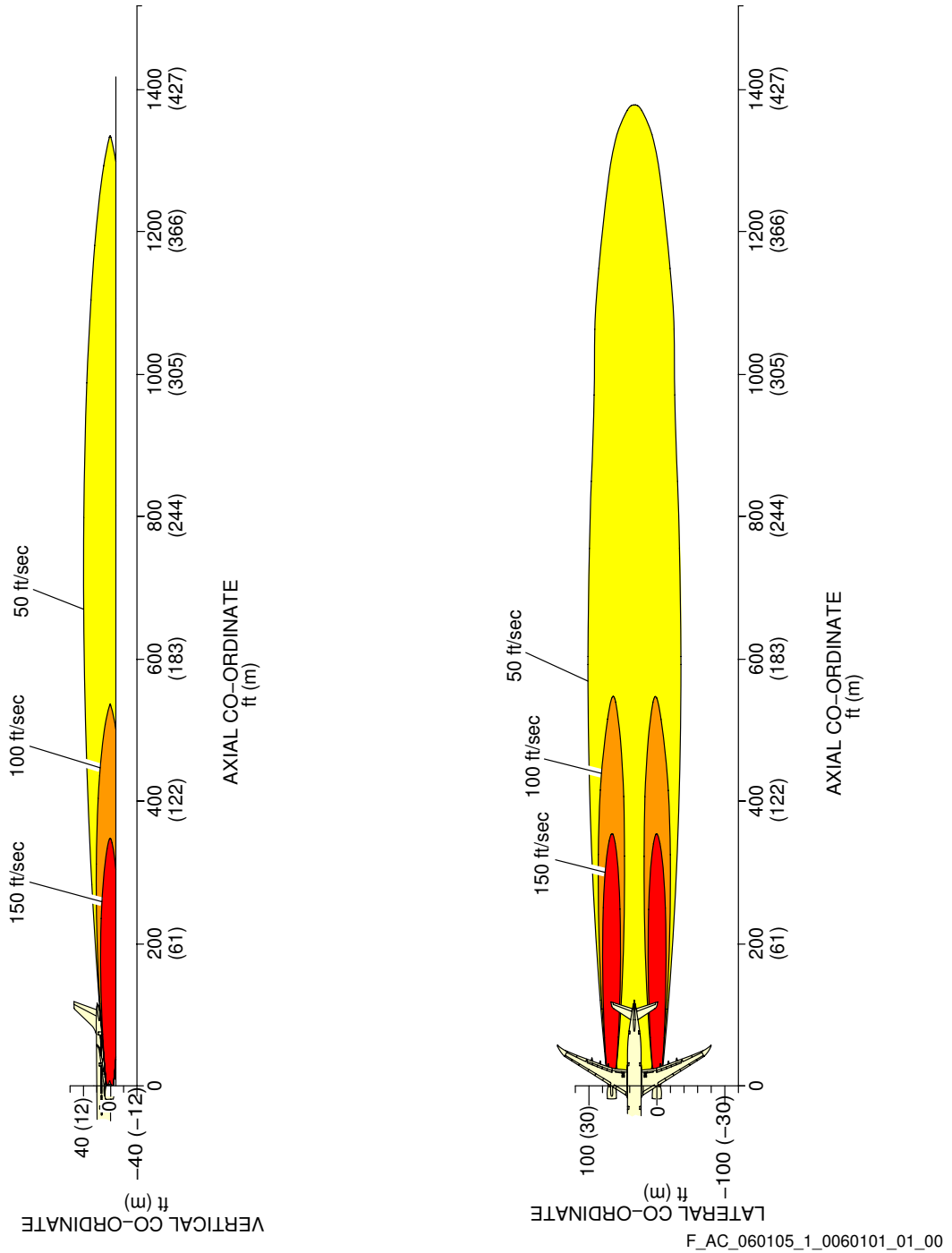

Engine Exhaust Velocities
 Takeoff Power - RR Trent 7000 series engine
 FIGURE-6-1-5-991-006-A01

6-1-6 Engine Exhaust Temperatures Contours - Takeoff Power****ON A/C A330-200 A330-200F A330-300 A330-800 A330-900**Engine Exhaust Temperatures Contours - Takeoff Power

1. This section gives engine exhaust temperatures contours at takeoff power.

**ON A/C A330-200 A330-200F A330-300

NOTE : TEMPERATURES ARE IN DEGREES FAHRENHEIT (DEGREES C).
TAKEOFF POWER - SEA LEVEL STATIC, ZERO WIND,
STANDARD DAY, ZERO RAMP GRADIENT ENGINE TYPE.

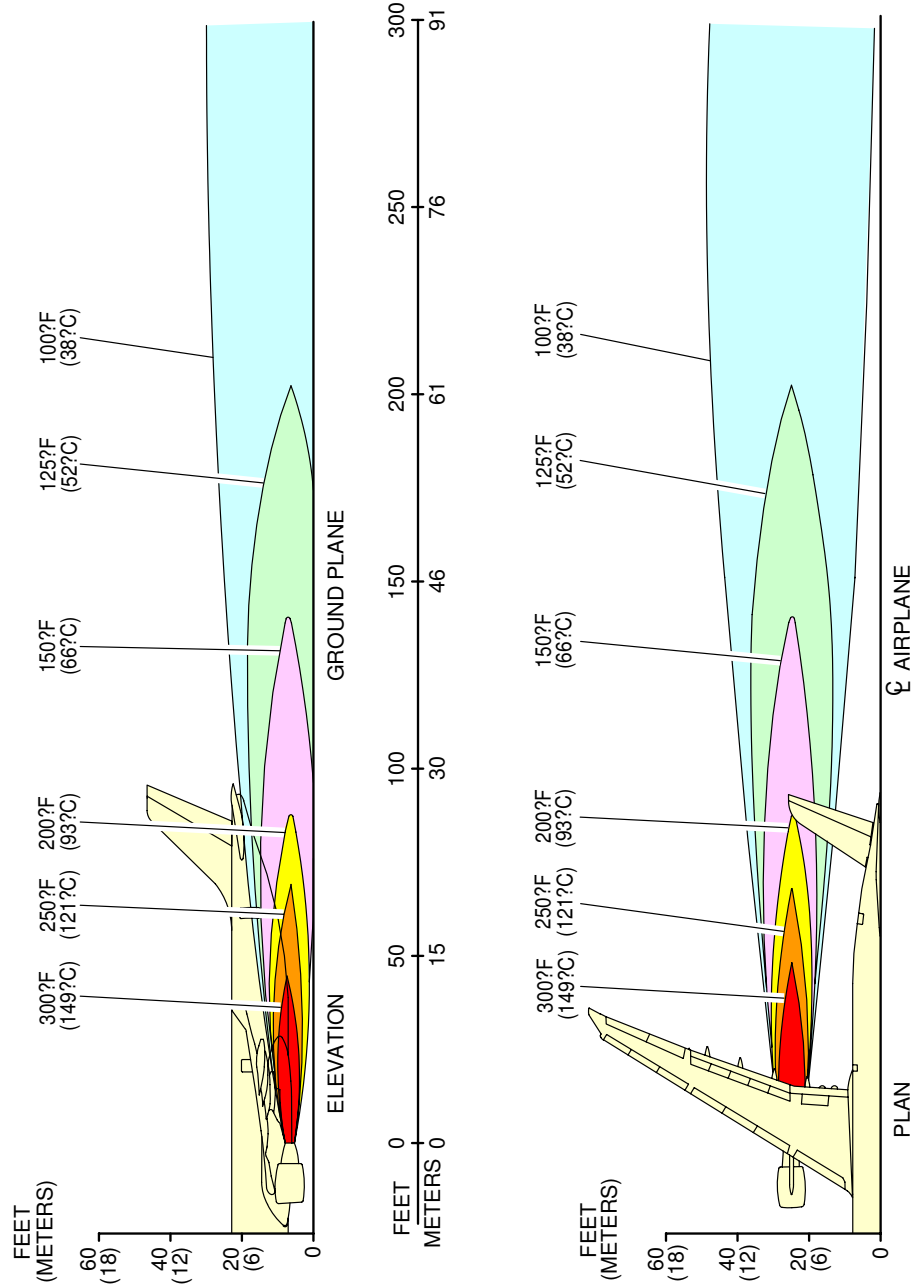

F_AC_060106_1_0010101_01_00

Engine Exhaust Temperatures
Takeoff Power - PW 4000 series engine
FIGURE-6-1-6-991-001-A01

G-00231 (0000)

****ON A/C A330-200 A330-200F A330-300**

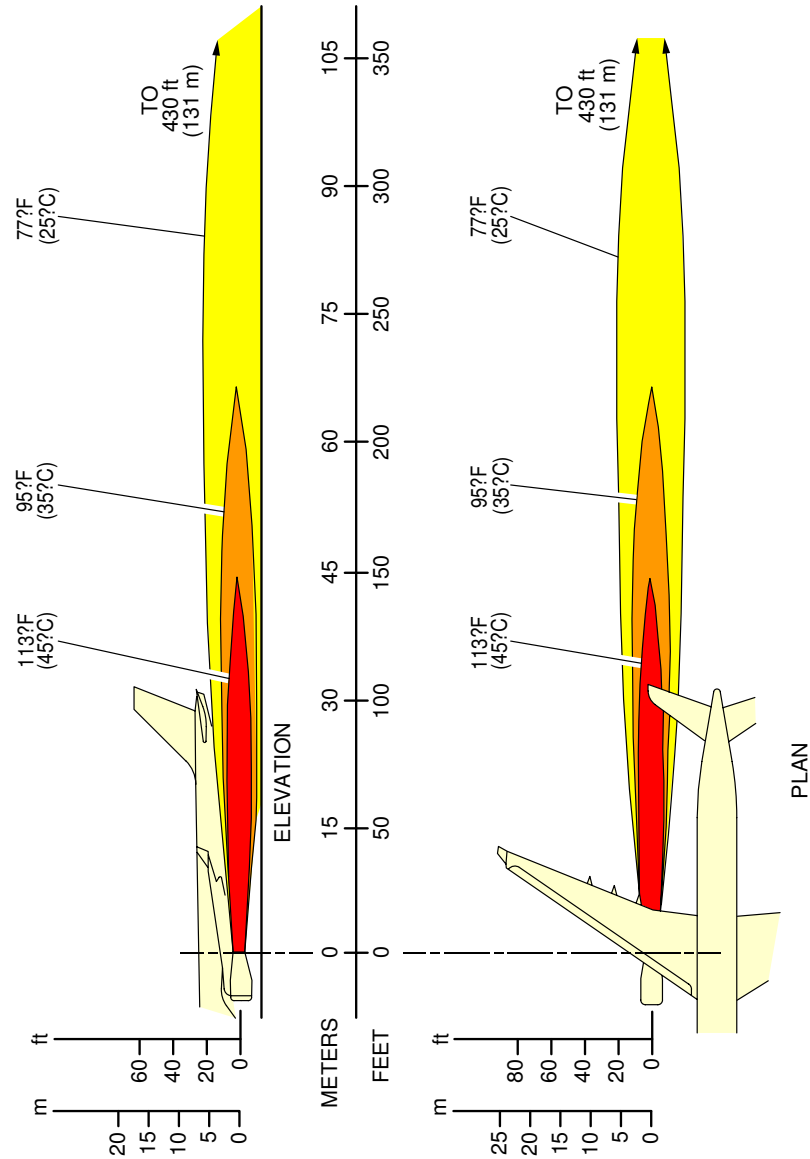

F_AC_060106_1_0020101_01_00

Engine Exhaust Temperatures
Takeoff Power - RR Trent 700 series engine
FIGURE-6-1-6-991-002-A01

**ON A/C A330-200 A330-300

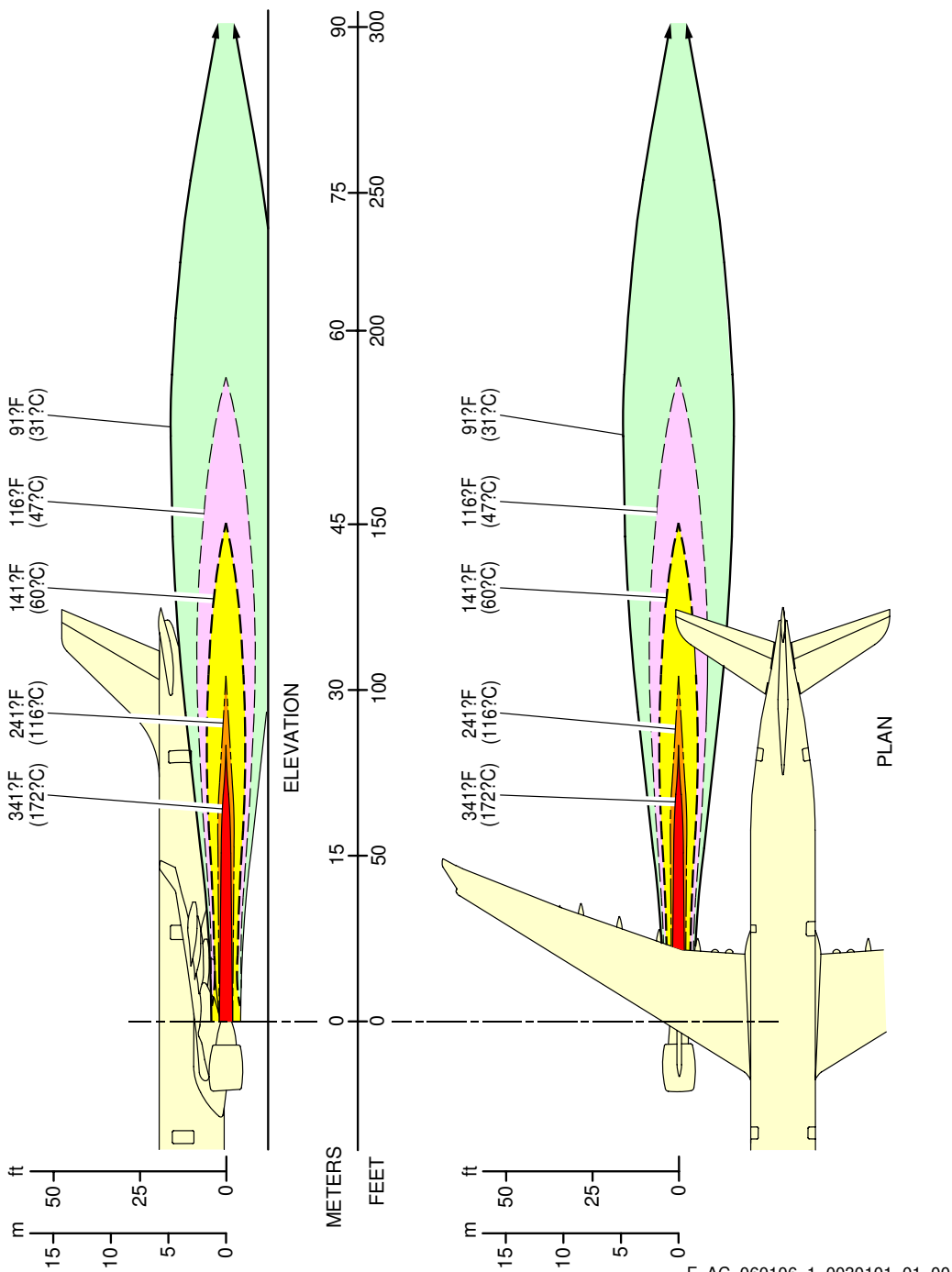

F_AC_060106_1_0030101_01_00

Engine Exhaust Temperatures
 Takeoff Power - GE CF6-80E1 series engine
 FIGURE-6-1-6-991-003-A01

**ON A/C A330-800 A330-900

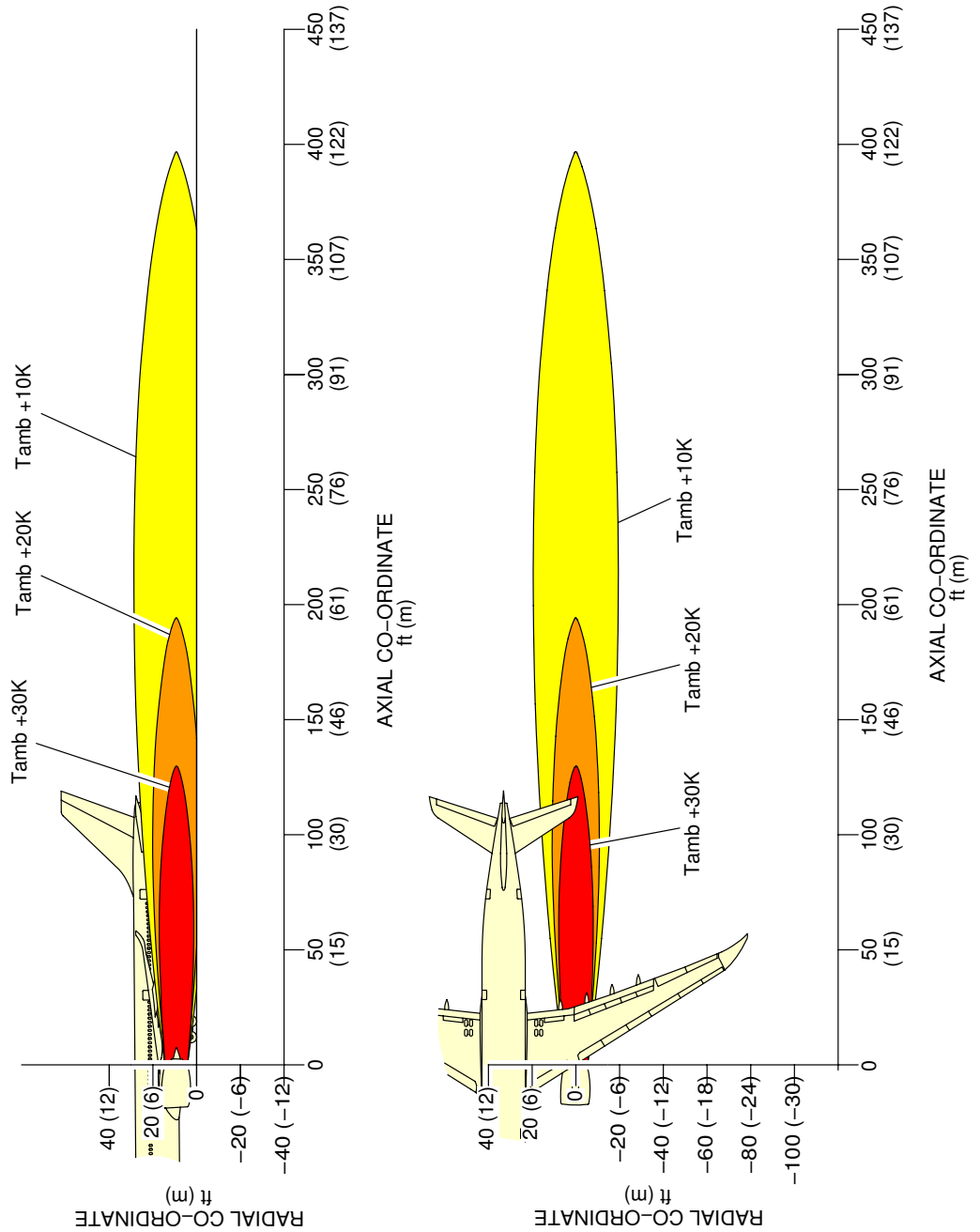

F_AC_060106_1_0060101_01_00

Engine Exhaust Temperatures
 Takeoff Power - RR Trent 7000 series engine
 FIGURE-6-1-6-991-006-A01

6-3-0 Danger Areas of Engines****ON A/C A330-200 A330-200F A330-300 A330-800 A330-900**Danger Areas of Engines

1. Danger Areas of the Engines.

NOTE : Areas with exhaust velocities of more than 56 km/h (35 mph, 50 ft/s or 15 m/s) are defined as areas where injury to persons and/or damage to machinery can occur.



6-3-1 Ground Idle Power

****ON A/C A330-200 A330-200F A330-300 A330-800 A330-900**

Ground Idle Power

1. This section provides danger areas of the engines at ground idle power conditions.

**ON A/C A330-200 A330-200F A330-300

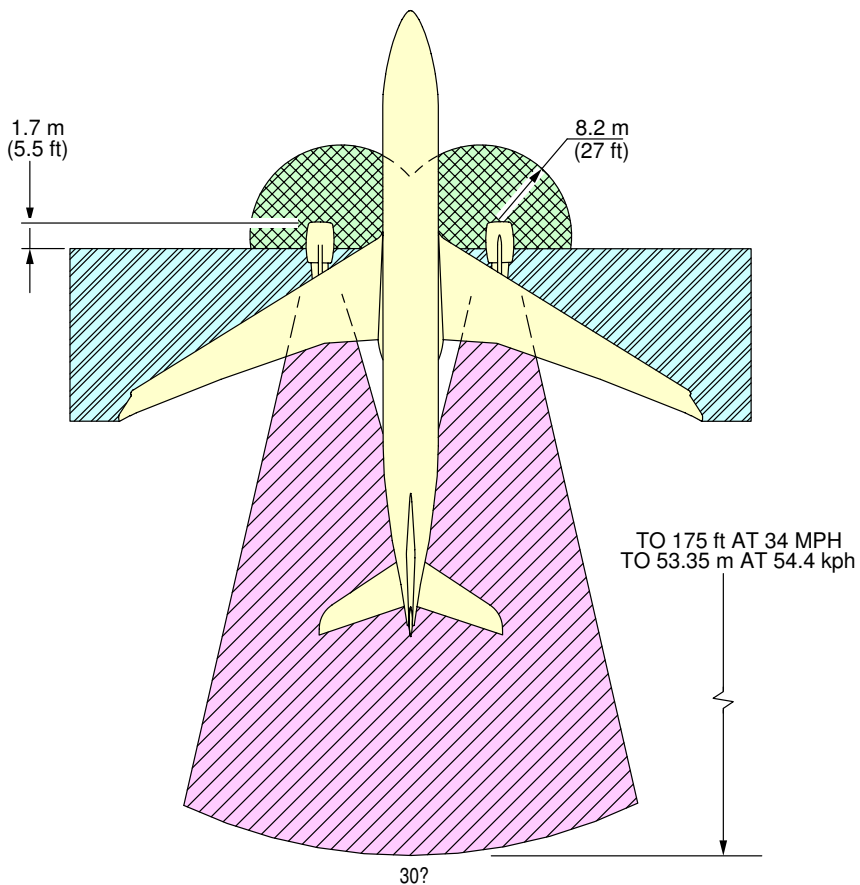

-  INTAKE SUCTION DANGER AREA
-  EXHAUST DANGER AREA
-  SAFE ENTRY AREA

G-00224(0992)



F_AC_060301_1_0010101_01_00

Danger Areas of Engines
PW 4000 Series Engine
FIGURE-6-3-1-991-001-A01

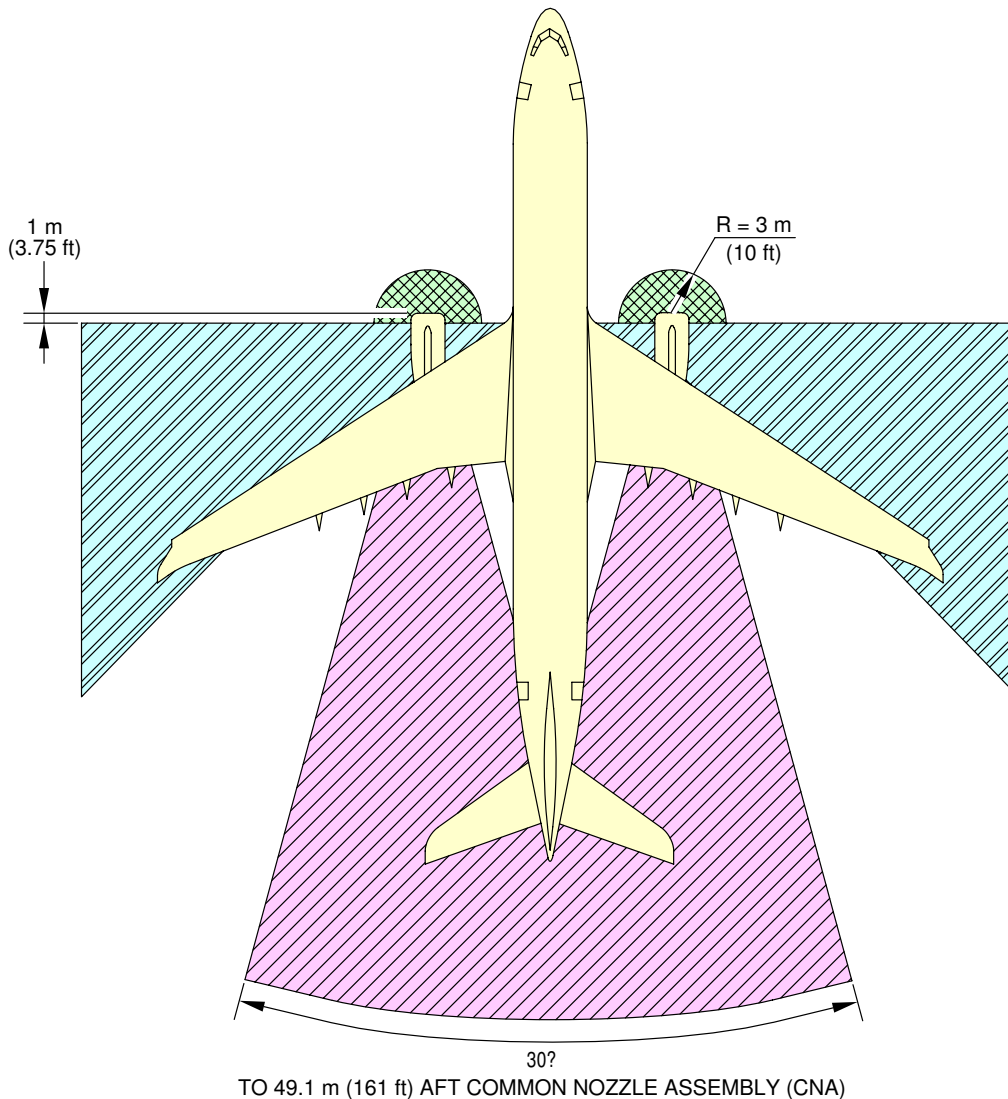
**ON A/C A330-200 A330-200F A330-300



NOTE:

-  INTAKE SUCTION DANGER AREA MINIMUM POWER
-  ENTRY CORRIDOR
-  EXHAUST DANGER AREA

D4816



F_AC_060301_1_0020101_01_01

Danger Areas of Engines
 RR Trent 700 Series Engine
 FIGURE-6-3-1-991-002-A01

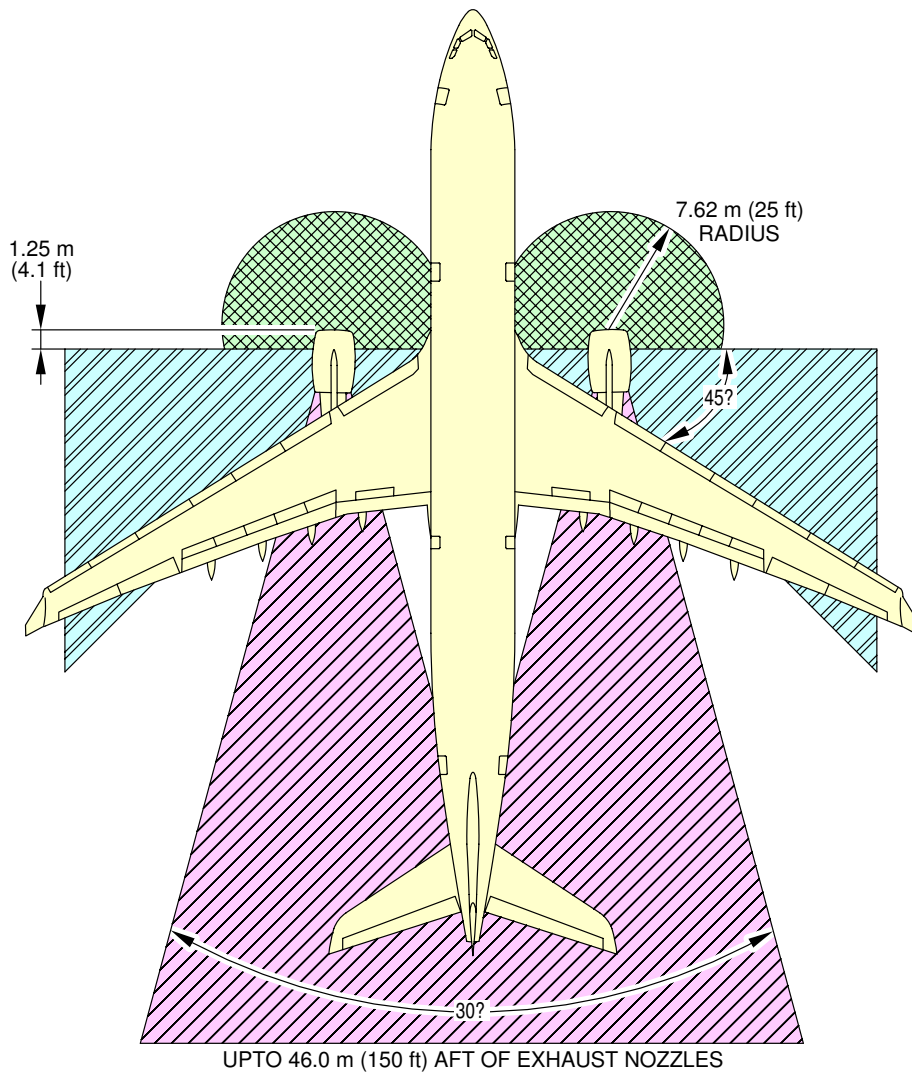
**ON A/C A330-200 A330-300



NOTE:

-  INTAKE SUCTION DANGER AREA
-  ENTRY CORRIDOR
-  EXHAUST DANGER AREA



F_AC_060301_1_0030101_01_02

Danger Areas of Engines
GE CF6-80E1 Series Engine
FIGURE-6-3-1-991-003-A01

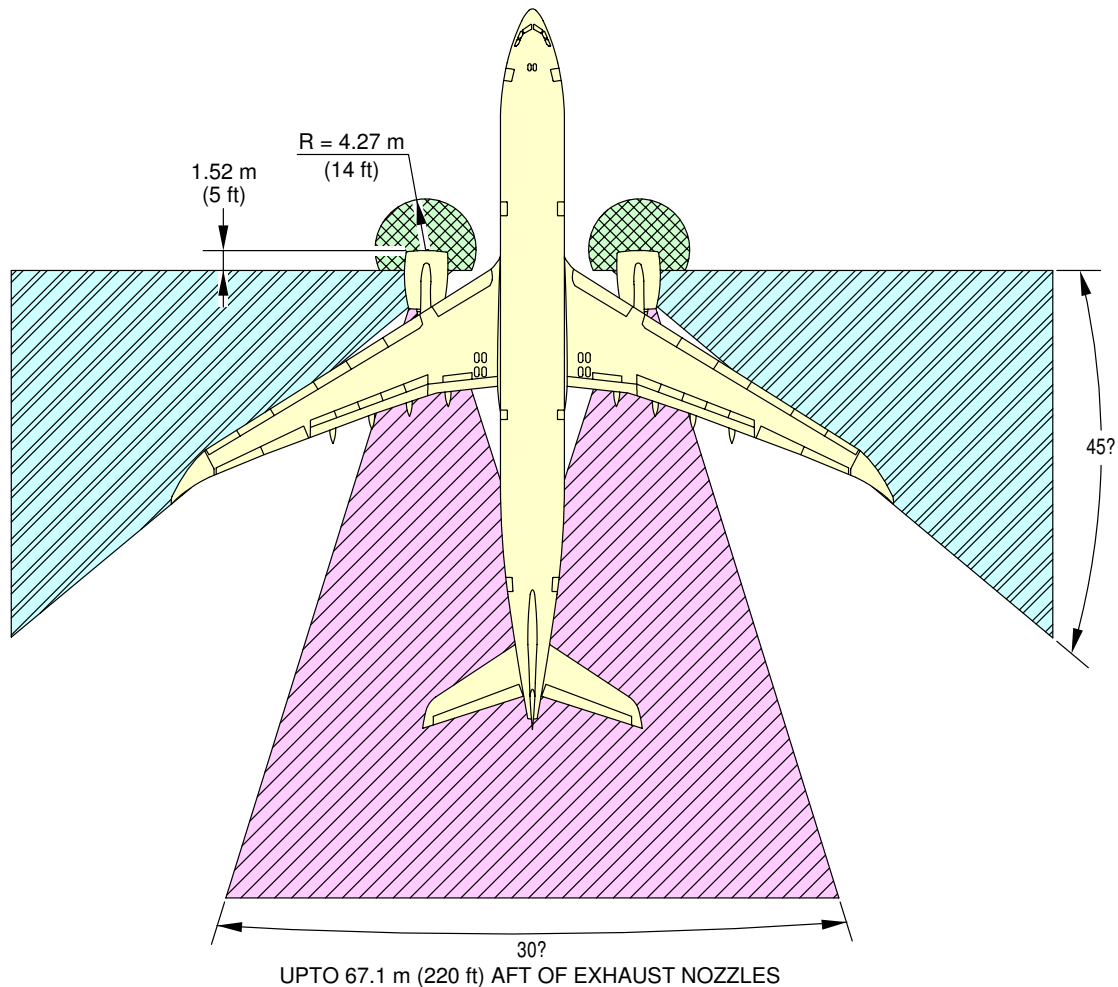
**ON A/C A330-800 A330-900



NOTE:

-  INTAKE SUCTION DANGER AREA
-  ENTRY CORRIDOR
-  EXHAUST DANGER AREA

F_AC_060301_1_0060101_01_00

Danger Areas of Engines
RR Trent 7000 Series Engine
FIGURE-6-3-1-991-006-A01



6-3-2 Breakaway Power

****ON A/C A330-200 A330-200F A330-300 A330-800 A330-900**



Breakaway Power

1. This section provides danger areas of the engines at breakaway power conditions.

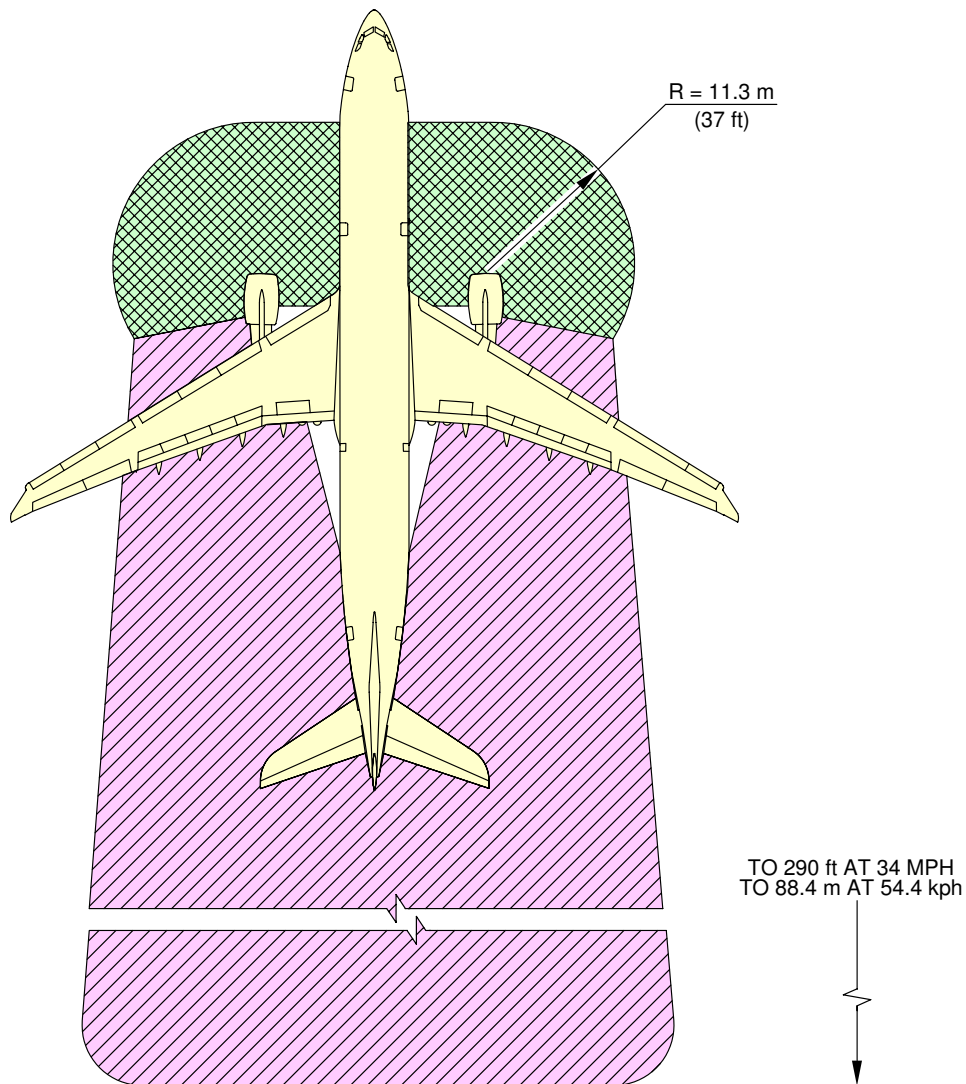
**ON A/C A330-200 A330-200F A330-300



NOTE:

-  INTAKE SUCTION DANGER AREA
-  EXHAUST DANGER AREA

G-03248 (0000)

F_AC_060302_1_0010101_01_01

Danger Areas of Engines
PW 4000 Series Engine
FIGURE-6-3-2-991-001-A01

**ON A/C A330-200 A330-200F A330-300

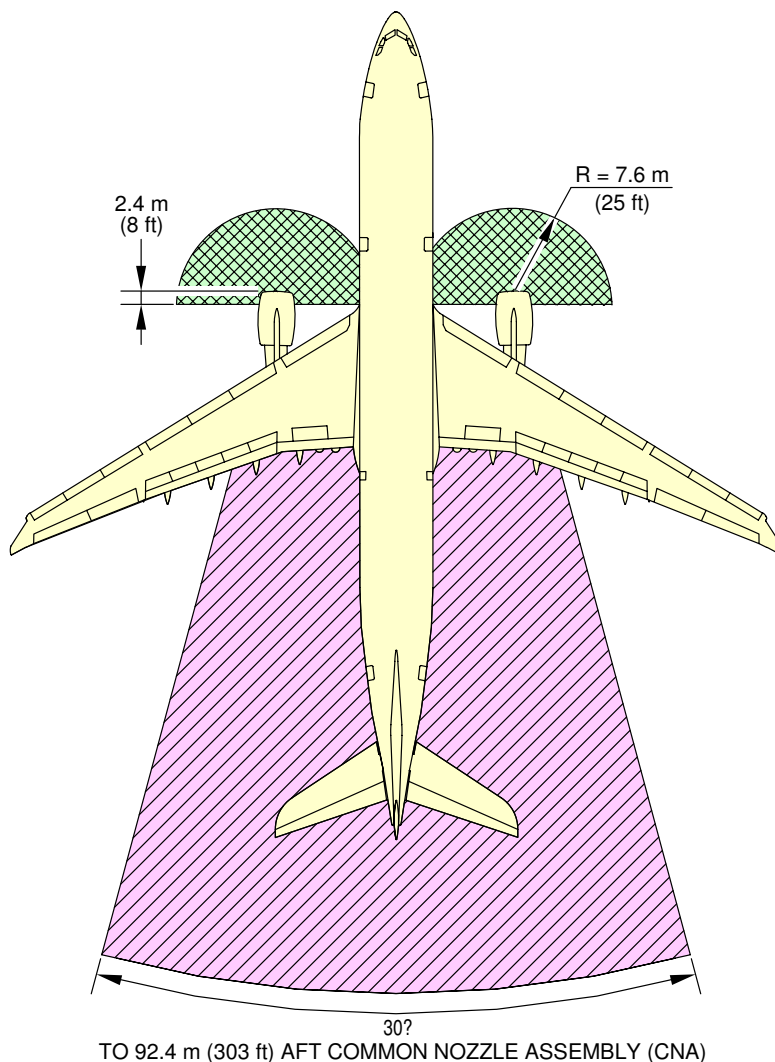

NOTE:



INTAKE SUCTION DANGER AREA BREAKAWAY POWER



EXHAUST DANGER AREA



F_AC_060302_1_0020101_01_01

Danger Areas of Engines
RR Trent 700 Series Engine
FIGURE-6-3-2-991-002-A01

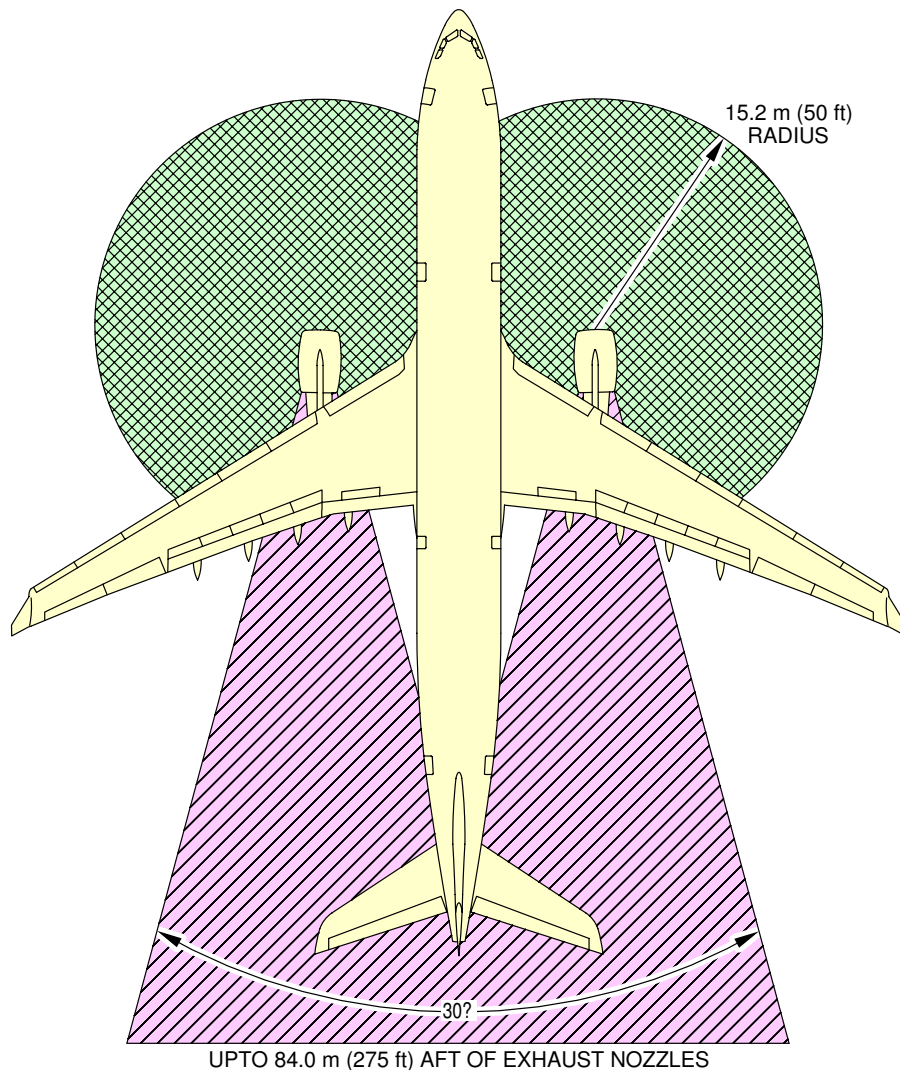
**ON A/C A330-200 A330-300



NOTE:

-  INTAKE SUCTION DANGER AREA
-  EXHAUST DANGER AREA



F_AC_060302_1_0030101_01_02

Danger Areas of Engines
GE CF6-80E1 Series Engine
FIGURE-6-3-2-991-003-A01

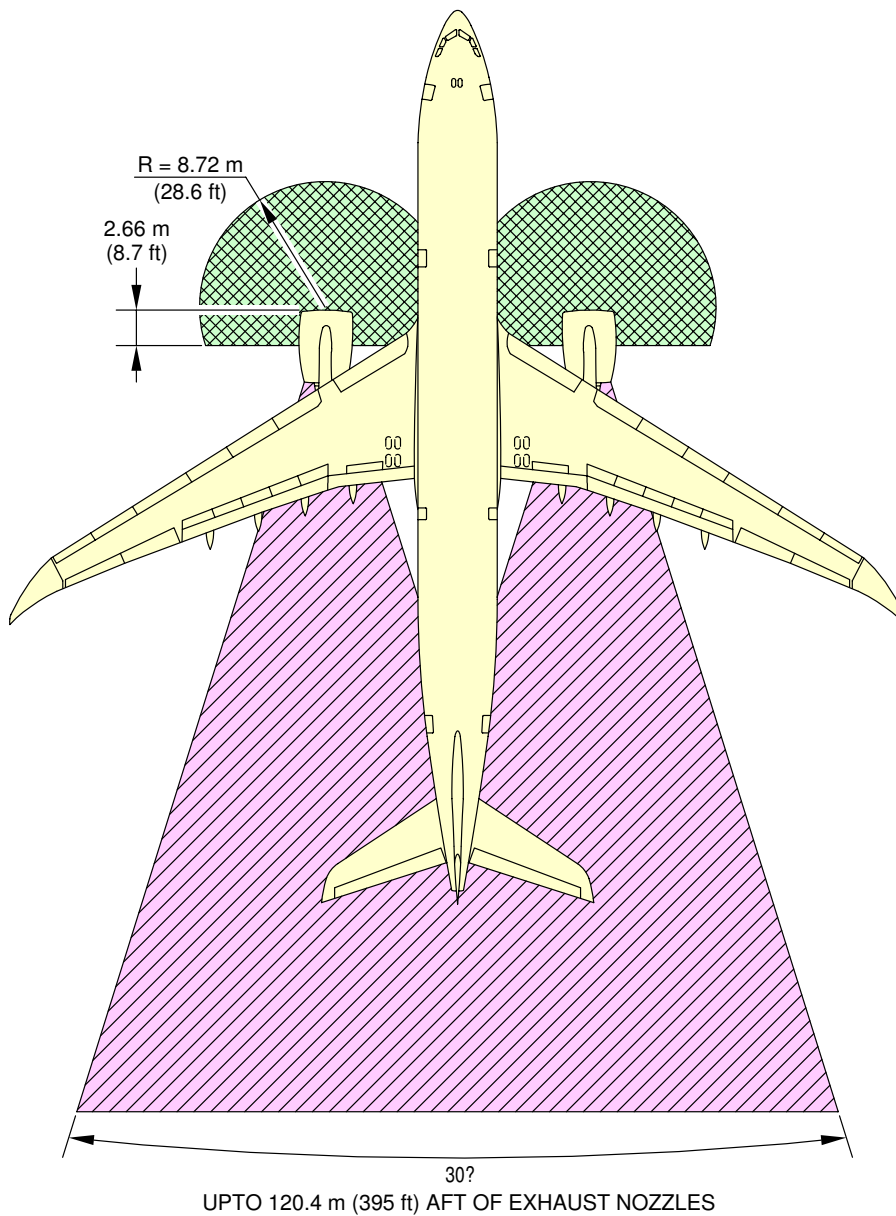
**ON A/C A330-800 A330-900



NOTE:

-  INTAKE SUCTION DANGER AREA
-  EXHAUST DANGER AREA

F_AC_060302_1_0060101_01_00

Danger Areas of Engines
RR Trent 7000 Series Engine
FIGURE-6-3-2-991-006-A01



6-3-3 Takeoff Power

****ON A/C A330-200 A330-200F A330-300 A330-800 A330-900**

Takeoff Power

1. This section provides danger areas of the engines at max take-off power conditions.

**ON A/C A330-200 A330-200F A330-300

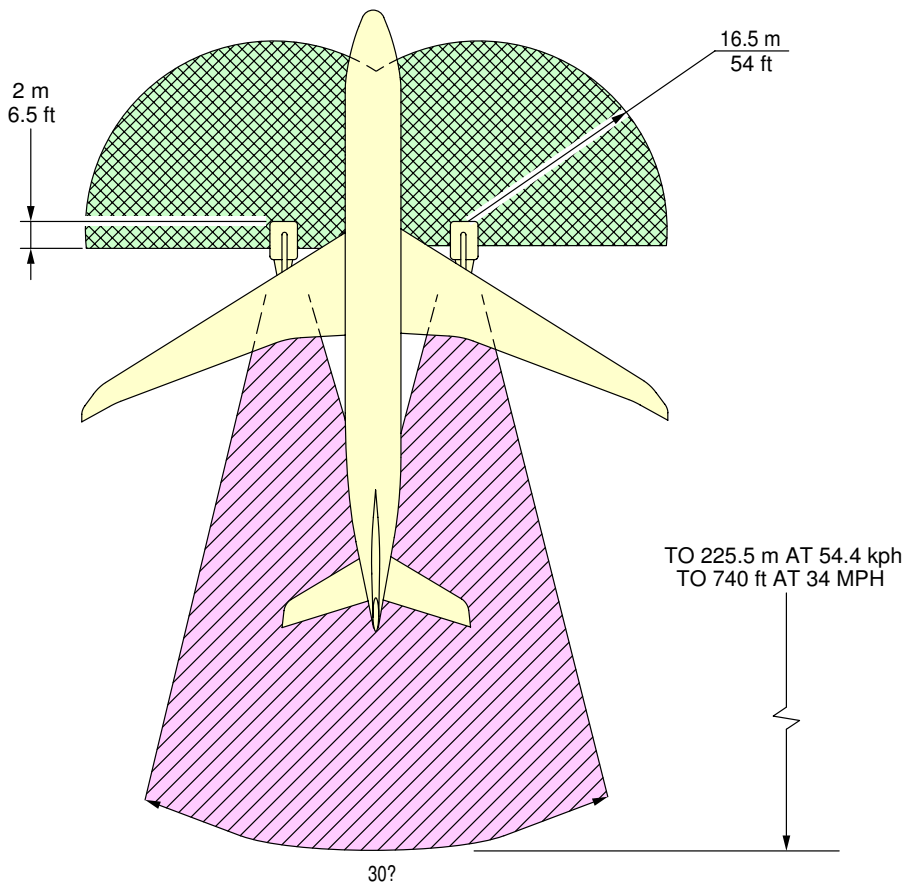

 INTAKE SUCTION
DANGER AREA

 EXHAUST DANGER
AREA

PW 4164 / PW 4168 -TAKEOFF

G - 00225 (0493)



F_AC_060303_1_0010101_01_00

Danger Areas of Engines
PW 4000 Series Engine
FIGURE-6-3-3-991-001-A01

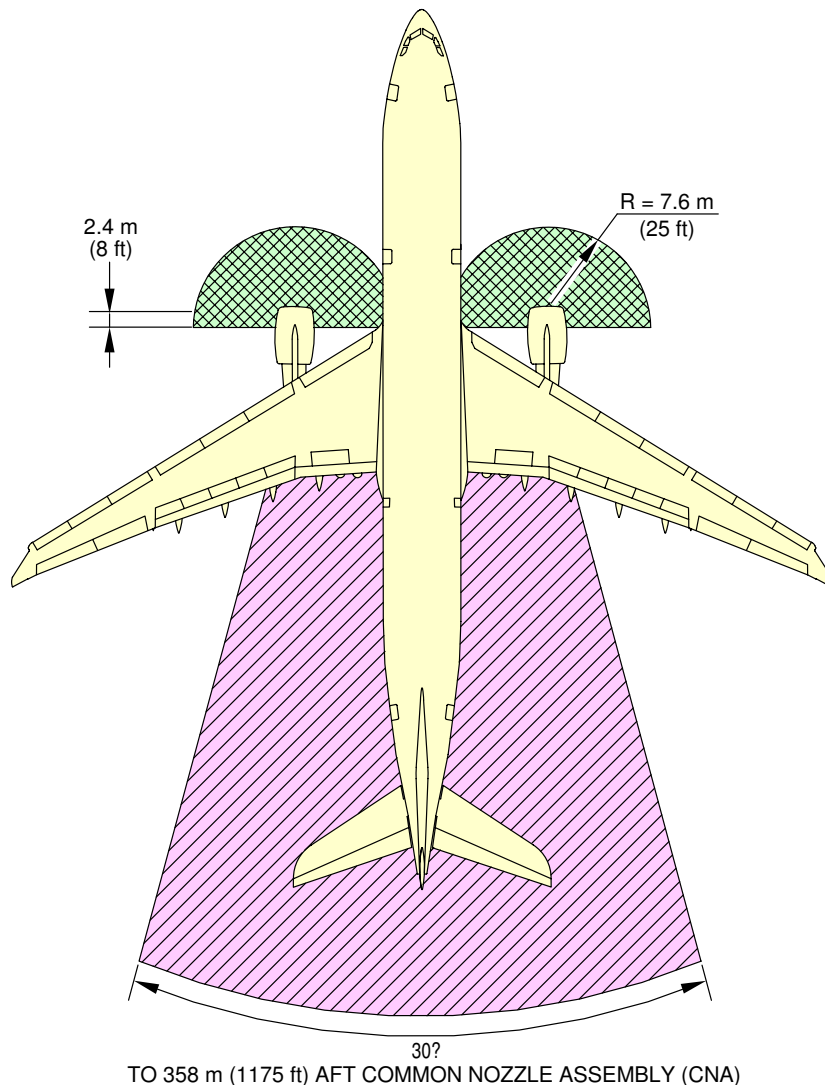
****ON A/C A330-200 A330-200F A330-300**



NOTE:

-  INTAKE SUCTION DANGER AREA TAKE-OFF POWER
-  EXHAUST DANGER AREA



F_AC_060303_1_0020101_01_01

Danger Areas of Engines
RR Trent 700 Series Engine
FIGURE-6-3-3-991-002-A01

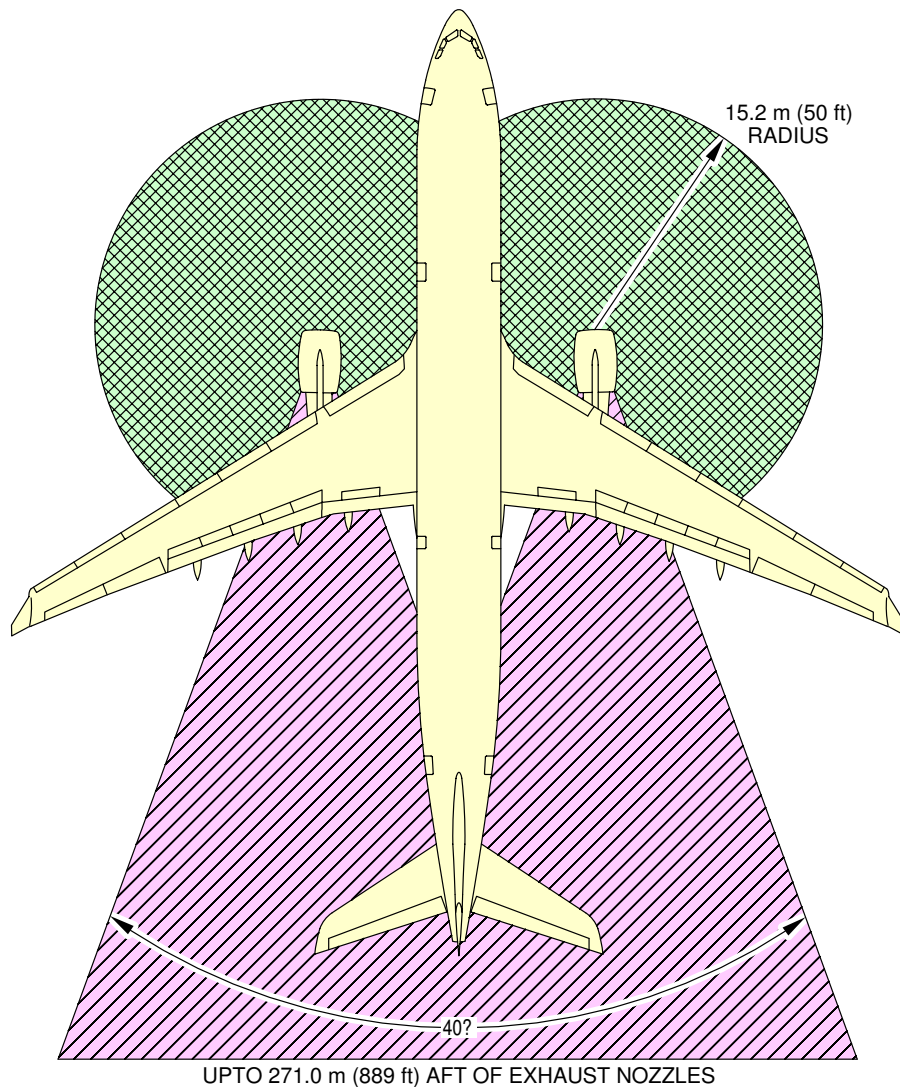
**ON A/C A330-200 A330-300



NOTE:

-  INTAKE SUCTION DANGER AREA
-  EXHAUST DANGER AREA



F_AC_060303_1_0030101_01_02

Danger Areas of Engines
GE CF6-80E1 Series Engine
FIGURE-6-3-3-991-003-A01

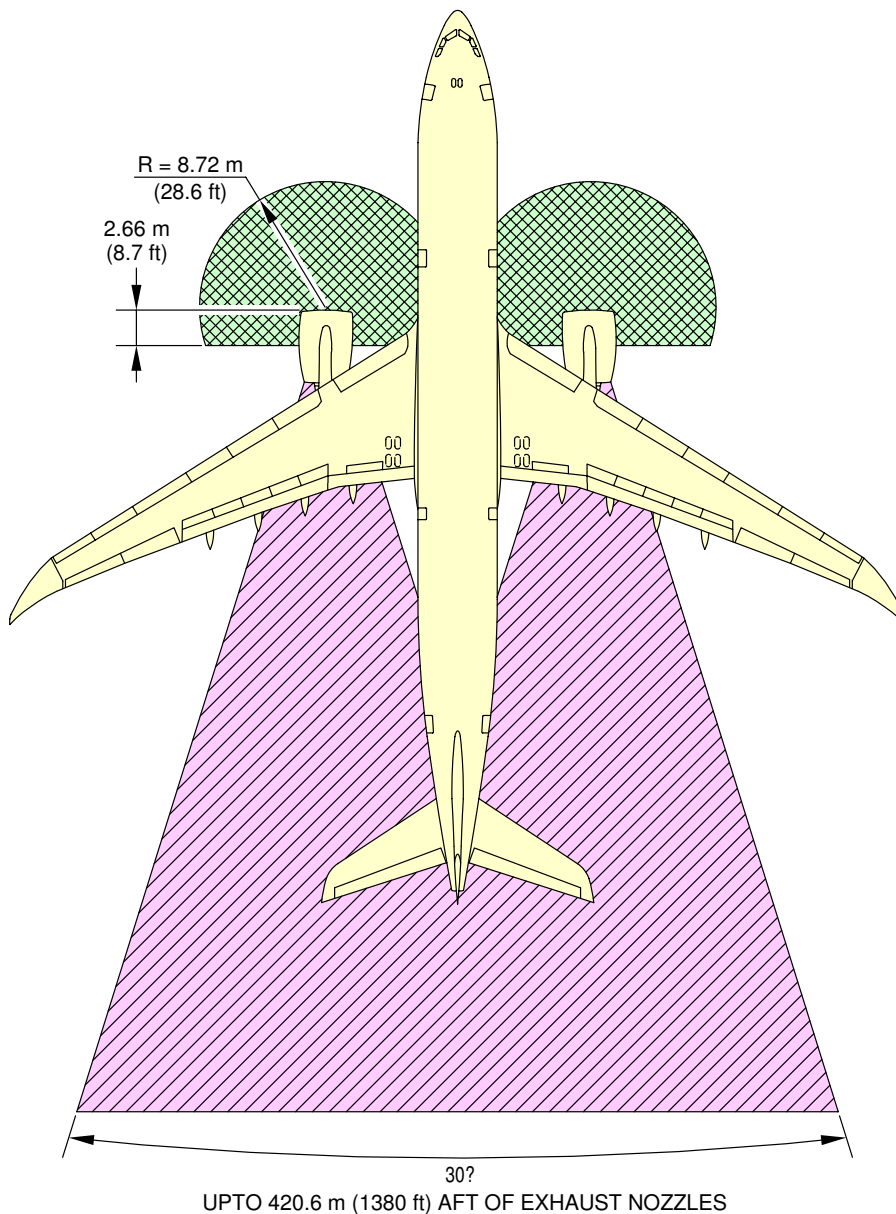
**ON A/C A330-800 A330-900



NOTE:

-  INTAKE SUCTION DANGER AREA
-  EXHAUST DANGER AREA

F_AC_060303_1_0060101_01_00

Danger Areas of Engines
RR Trent 7000 Series Engine
FIGURE-6-3-3-991-006-A01



6-4-0 APU Exhaust Velocities and Temperatures

****ON A/C A330-200 A330-200F A330-300 A330-800 A330-900**

APU Exhaust Velocities and Temperatures

1. APU Exhaust Velocities and Temperatures.



6-4-1 APU

**ON A/C A330-200 A330-200F A330-300 A330-800 A330-900

APU - GARRETT

1. This section gives APU exhaust velocities and temperatures

**ON A/C A330-200 A330-200F A330-300 A330-800 A330-900

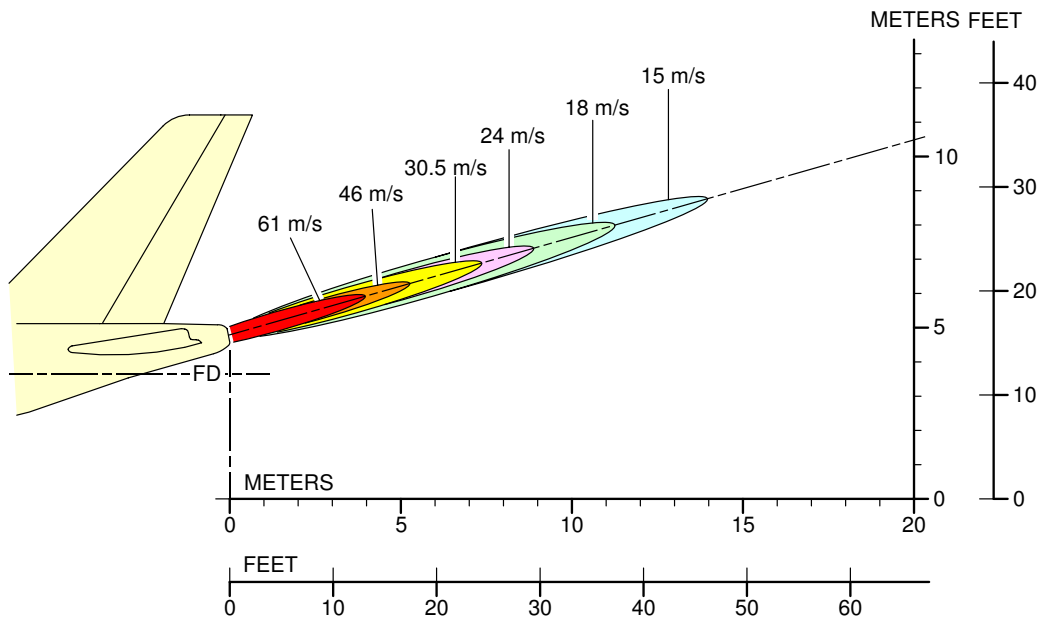
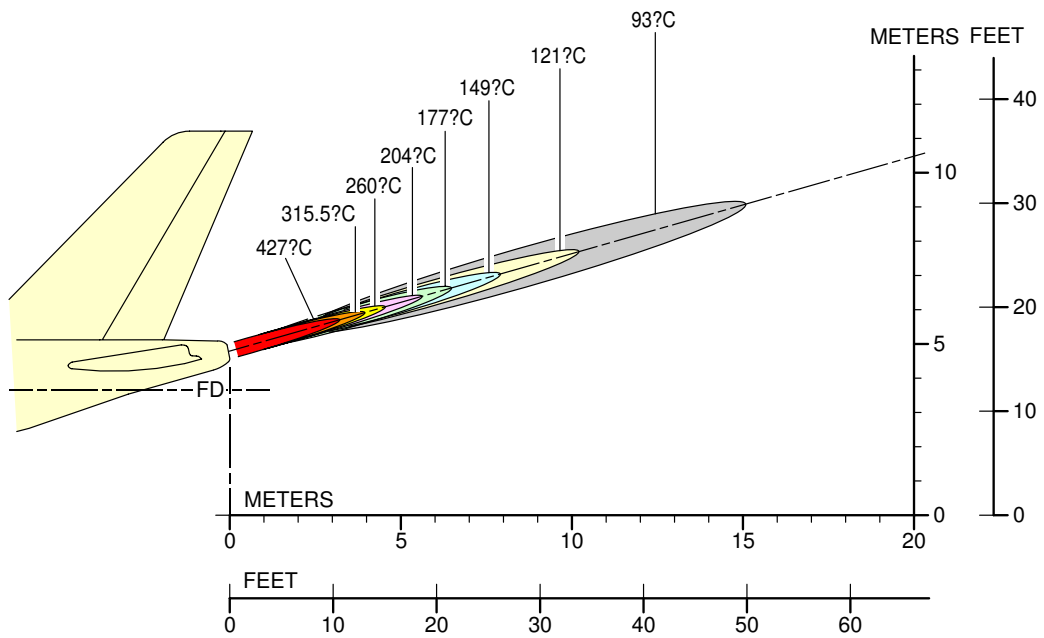

F_AC_060401_1_0010101_01_00

Exhaust Velocities and Temperatures
 APU - GARRETT GTCP 331-350
 FIGURE-6-4-1-991-001-A01

PAVEMENT DATA

7-1-0 General Information

****ON A/C A330-200 A330-200F A330-300 A330-800 A330-900**General Information

1. A brief description of the pavement charts that follow will help in the airport planning. To aid in the interpolation between the discrete values shown, each aircraft configuration is shown with a minimum range of five loads on the Main Landing Gear (MLG). All curves on the charts represent data at a constant specified tire pressure with:
 - The aircraft loaded to the Maximum Ramp Weight (MRW)
 - The CG at its maximum permitted aft position.Pavement requirements for commercial aircraft are derived from the static analysis of loads imposed on the MLG struts.
Landing Gear Footprint:
Section 07-02-00 gives basic data on the landing-gear footprint configuration, MRW, tire dimensions and pressures.
Maximum Pavement Loads:
Section 07-03-00 shows maximum vertical and horizontal pavement loads for specific critical conditions at the tire-ground interfaces.
Landing Gear Loading on Pavement:
The curves related to the landing gear loading on pavement are not given in section 07-04-00. Because the relationship between the aircraft weight, the center of gravity and the landing gear loading on the pavement is not strictly linear, it cannot be shown in chart format. But you can find in section 07-03-00 the maximum vertical and horizontal pavement loads for some critical conditions at the tire/ground interfaces for all the operational weight variants of the aircraft. For questions that are related to landing gear loading on pavement, contact Airbus.
Flexible Pavement Requirements - US Army Corps of Engineers Design Method:
The flexible pavement-requirements curves as per as U.S. Army Corps of Engineers Design Method are not given in section 07-05-00 since the related data is available through free software. Sections 07-02-00 and 07-03-00 gives all the inputs data required for the use of such software. For questions that are related to the flexible pavement requirements, contact Airbus.
Flexible Pavement Requirements - LCN Conversion Method:
The Load Classification Number (LCN) curves are not given in section 07-06-00 since the LCN system for the reporting pavement strength is old and are replaced by the ICAO recommended ACN/PCN system in 1983 and ACR/PCR system in 2020. For questions that are related to the LCN system, contact Airbus.
Rigid Pavement Requirements - PCA (Portland Cement Association) Design Method:
The rigid-pavement requirements curves as per as Portland Cement Association Design Method are not given in section 07-07-00 since the related data is available through free software. Sections 07-02-00 and 07-03-00 gives all the inputs data required for the use of such software. For questions that are related to the rigid pavement requirements, contact Airbus.

Rigid Pavement Requirements - LCN Conversion:

The Load Classification Number (LCN) curves are not given in section 07-08-00 since the LCN system for the reporting pavement strength is old and are replaced by the ICAO recommended ACN/PCN system in 1983 and ACR/PCR system in 2020.

For questions that are related to the LCN system, contact Airbus.

ACN/PCN Reporting System:

Section 07-09-00 gives ACN data prepared according to the ACN/PCN system as referenced in ICAO Annex 14, "Aerodromes", Volume 1 "Aerodrome Design and Operations".

Eighth Edition July 2018, incorporating Amendments 1 to 14 and ICAO doc 9157, "Aerodrome Design Manual", part 3 "Pavements" Second Edition 1983.

The ACN/PCN system is applicable until November 2024.

ACN is the Aircraft Classification Number and PCN is the related Pavement Classification Number.

An aircraft with an ACN less than or equal to the PCN can operate without restriction on the pavement.

Numerically the ACN is two times the derived single-wheel load expressed in thousands of kilograms. The derived single-wheel load is calculated as the load on a single tire inflated to 1.25 MPa (181 psi) that can have the same pavement requirements as the aircraft.

Computationally the ACN/PCN system uses the PCA program PDILB for rigid pavements and S-77-1 for flexible pavements to calculate ACN values.

The airport authority must select the method of pavement analysis.

The results of their analysis should be reported with the following format:

PCN			
PAVEMENT TYPE	SUBGRADE CATEGORY	TIRE PRESSURE CATEGORY	EVALUATION METHOD
R - Rigid	A - High	W - No Pressure Limit	T - Technical
F - Flexible	B - Medium	X - High Pressure Limited to 1.75 MPa (254 psi)	U - Using Aircraft
	C - Low	Y - Medium Pressure Limited to 1.25 MPa (181 psi)	
	D - Ultra Low	Z - Low Pressure Limited to 0.5 MPa (73 psi)	

Section 07-09-00 shows the aircraft ACN values.

For flexible pavements, the four subgrade categories (CBR) are:

A. High Strength	CBR 15
B. Medium Strength	CBR 10
C. Low Strength	CBR 6
D. Ultra Low Strength	CBR 3

For rigid pavements, the four subgrade categories (k) are:

A. High Strength	$k = 150 \text{ MN/m}^3$ (550 pci)
B. Medium Strength	$k = 80 \text{ MN/m}^3$ (300 pci)
C. Low Strength	$k = 40 \text{ MN/m}^3$ (150 pci)
D. Ultra Low Strength	$k = 20 \text{ MN/m}^3$ (75 pci)

ACR/PCR Reporting System:

Section 07-10-00 gives ACR data prepared according to the ACR/PCR system as referenced in ICAO Annex 14, "Aerodromes", Volume 1 "Aerodrome Design and Operations".

Eight Edition July 2018, incorporating Amendments 1 to 15 and ICAO doc 9157, "Aerodrome Design Manual", part 3 "Pavements" Third Edition 2021.

The ACR/PCR system is effective from November 2020 and will be applicable in November 2024.

ACR is the Aircraft Classification Rating and PCR is the related Pavement Classification Rating.

An aircraft with an ACR less than or equal to the PCR can operate without restriction on the pavement.

Numerically the ACR is two times the derived single-wheel load expressed in hundreds of kilograms.

The derived single-wheel load is calculated as the load on a single tire inflated to 1.50 Mpa (218 psi) that can have the same pavement requirements as the aircraft.

Computationally the ACR/PCR system relies on the Linear Elastic Analysis (LEA). The ACR are computed with the official ICAO-ACR software.

States can start their own methods for PCR determination, which agree with the overall parameters of the ACR/PCR method.

The results of their analysis should be reported with the following format:

PCR			
PAVEMENT TYPE	SUBGRADE CATEGORY	TIRE PRESSURE CATEGORY	EVALUATION METHOD
R - Rigid	A - High	W - No Pressure Limit	T - Technical
F - Flexible	B - Medium	X - High Pressure Limited to 1.75 MPa (254 psi)	U - Using Aircraft
	C - Low	Y - Medium Pressure Limited to 1.25 MPa (181 psi)	
	D - Ultra Low	Z - Low Pressure Limited to 0.5 MPa (73 psi)	

Section 07-10-00 shows the aircraft ACR values.

For flexible and rigid pavement, the four subgrade categories are defined based on the subgrade modulus of elasticity (E):

A. High Strength	$E = 200 \text{ MPa}$ (29 008 psi)
B. Medium Strength	$E = 120 \text{ MPa}$ (17 405 psi)

C. Low Strength	E = 80 MPa (11 603 psi)
D. Ultra Low Strength	E = 50 MPa (7 252 psi)

7-2-0 Landing Gear Footprint****ON A/C A330-200 A330-200F A330-300 A330-800 A330-900**Landing Gear Footprint

1. This section gives data about the landing gear footprint in relation to the aircraft MRW, tire sizes and pressures.
The landing-gear footprint information is given for all the operational weight variants of the aircraft.

**ON A/C A330-200

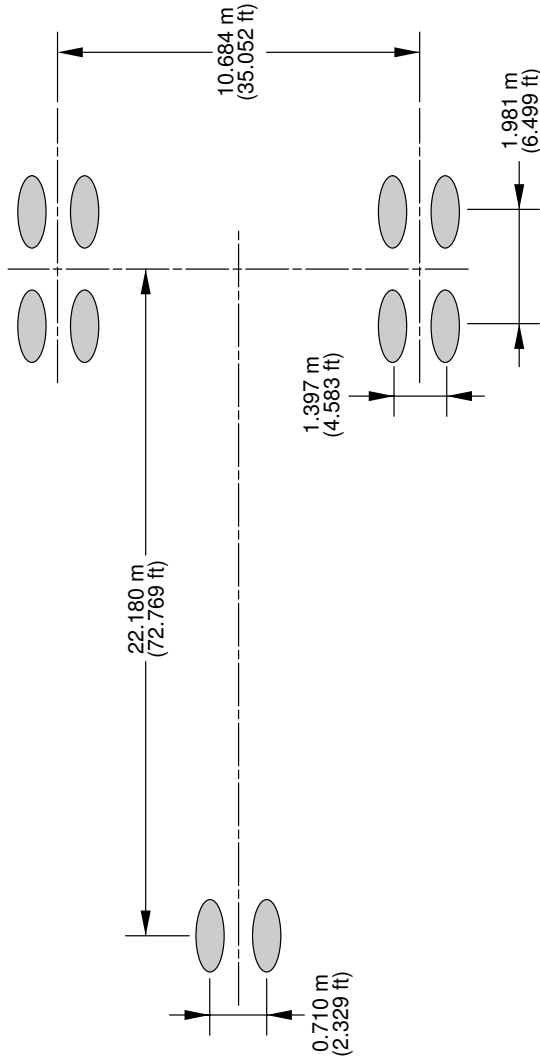

WEIGHT VARIANT	MAXIMUM RAMP WEIGHT	PERCENTAGE OF WEIGHT ON MAIN GEAR GROUP	NOSE GEAR TIRE SIZE	NOSE GEAR TIRE PRESSURE	MAIN GEAR TIRE SIZE	MAIN GEAR TIRE PRESSURE
A330-200 WV020	230 900 kg (509 050 lb)	94.7%	1050x395R16	12.7 bar (184 psi)	1400x530R23 OR 54x21-23 (bias)	14.2 bar (206 psi)
A330-200 WV021	230 900 kg (509 050 lb)	94.7%	1050x395R16	12.7 bar (184 psi)	1400x530R23 OR 54x21-23 (bias)	14.2 bar (206 psi)
A330-200 WV022	233 900 kg (515 650 lb)	94.6%	1050x395R16	12.7 bar (184 psi)	1400x530R23 OR 54x21-23 (bias)	14.2 bar (206 psi)
A330-200 WV023	233 900 kg (515 650 lb)	94.6%	1050x395R16	12.7 bar (184 psi)	1400x530R23 OR 54x21-23 (bias)	14.2 bar (206 psi)
A330-200 WV024	202 900 kg (447 325 lb)	94.9%	1050x395R16	12.7 bar (184 psi)	1400x530R23 OR 54x21-23 (bias)	14.2 bar (206 psi)
A330-200 WV025	220 900 kg (487 000 lb)	94.7%	1050x395R16	12.7 bar (184 psi)	1400x530R23 OR 54x21-23 (bias)	14.2 bar (206 psi)
A330-200 WV026	192 900 kg (425 275 lb)	95.0%	1050x395R16	12.7 bar (184 psi)	1400x530R23 OR 54x21-23 (bias)	14.2 bar (206 psi)

F_AC_070200_1_0030101_01_06

Landing Gear Footprint
(Sheet 1 of 3)
FIGURE-7-2-0-991-003-A01

**ON A/C A330-200

WEIGHT VARIANT	MAXIMUM RAMP WEIGHT	PERCENTAGE OF WEIGHT ON MAIN GEAR GROUP	NOSE GEAR TIRE SIZE	NOSE GEAR TIRE PRESSURE	MAIN GEAR TIRE SIZE	MAIN GEAR TIRE PRESSURE
A330-200 WV027	220 900 kg (487 000 lb)	94.7%	1050x395R16	12.7 bar (184 psi)	1400x530R23 OR 54x21-23 (bias)	14.2 bar (206 psi)
A330-200 WV050	230 900 kg (509 050 lb)	94.7%	1050x395R16	12.7 bar (184 psi)	1400x530R23 OR 54x21-23 (bias)	14.2 bar (206 psi)
A330-200 WV051	192 900 kg (425 275 lb)	95.0%	1050x395R16	12.7 bar (184 psi)	1400x530R23 OR 54x21-23 (bias)	14.2 bar (206 psi)
A330-200 WV052	233 900 kg (515 650 lb)	94.6%	1050x395R16	12.7 bar (184 psi)	1400x530R23 OR 54x21-23 (bias)	14.2 bar (206 psi)
A330-200 WV053	210 900 kg (464 950 lb)	94.8%	1050x395R16	12.7 bar (184 psi)	1400x530R23 OR 54x21-23 (bias)	14.2 bar (206 psi)
A330-200 WV054	230 900 kg (509 050 lb)	94.7%	1050x395R16	12.7 bar (184 psi)	1400x530R23 OR 54x21-23 (bias)	14.2 bar (206 psi)
A330-200 WV055	192 900 kg (425 275 lb)	95.0%	1050x395R16	12.7 bar (184 psi)	1400x530R23 OR 54x21-23 (bias)	14.2 bar (206 psi)
A330-200 WV056	233 900 kg (515 650 lb)	94.6%	1050x395R16	12.7 bar (184 psi)	1400x530R23 OR 54x21-23 (bias)	14.2 bar (206 psi)
A330-200 WV057	236 900 kg (522 275 lb)	93.4%	1050x395R16	12.7 bar (184 psi)	1400x530R23	14.2 bar (206 psi)
A330-200 WV058	238 900 kg (526 675 lb)	92.6%	1050x395R16	12.7 bar (184 psi)	1400x530R23	14.2 bar (206 psi)
A330-200 WV059	202 900 kg (447 325 lb)	94.9%	1050x395R16	12.7 bar (184 psi)	1400x530R23 OR 54x21-23 (bias)	14.2 bar (206 psi)
A330-200 WV060	220 900 kg (487 000 lb)	94.8%	1050x395R16	12.7 bar (184 psi)	1400x530R23 OR 54x21-23 (bias)	14.2 bar (206 psi)
A330-200 WV061	230 900 kg (509 050 lb)	94.7%	1050x395R16	12.7 bar (184 psi)	1400x530R23	14.2 bar (206 psi)
A330-200 WV062	238 900 kg (526 675 lb)	92.6%	1050x395R16	12.7 bar (184 psi)	1400x530R23	14.2 bar (206 psi)
A330-200 WV063	192 900 kg (425 275 lb)	95.0%	1050x395R16	12.7 bar (184 psi)	1400x530R23	14.2 bar (206 psi)

F_AC_070200_1_0030104_01_05

Landing Gear Footprint
(Sheet 2 of 3)
FIGURE-7-2-0-991-003-A01

**ON A/C A330-200

WEIGHT VARIANT	MAXIMUM RAMP WEIGHT	PERCENTAGE OF WEIGHT ON MAIN GEAR GROUP	NOSE GEAR TIRE SIZE	NOSE GEAR TIRE PRESSURE	MAIN GEAR TIRE SIZE	MAIN GEAR TIRE PRESSURE
A330-200 WV064	217 900 kg (480 375 lb)	94.8%	1050x395R16	12.7 bar (184 psi)	1400x530R23	14.2 bar (206 psi)
A330-200 WV080	238 900 kg (526 675 lb)	93.5%	1050x395R16	12.7 bar (184 psi)	1400x530R23	14.7 bar (213 psi)
A330-200 WV081	242 900 kg (535 500 lb)	92.6%	1050x395R16	12.7 bar (184 psi)	1400x530R23	14.7 bar (213 psi)
A330-200 WV082	242 900 kg (535 500 lb)	92.6%	1050x395R16	12.7 bar (184 psi)	1400x530R23	14.7 bar (213 psi)
A330-200 WV083	240 900 kg (531 100 lb)	93.1%	1050x395R16	12.7 bar (184 psi)	1400x530R23	14.7 bar (213 psi)

F_AC_070200_1_0030106_01_01

Landing Gear Footprint
(Sheet 3 of 3)
FIGURE-7-2-0-991-003-A01

**ON A/C A330-200F

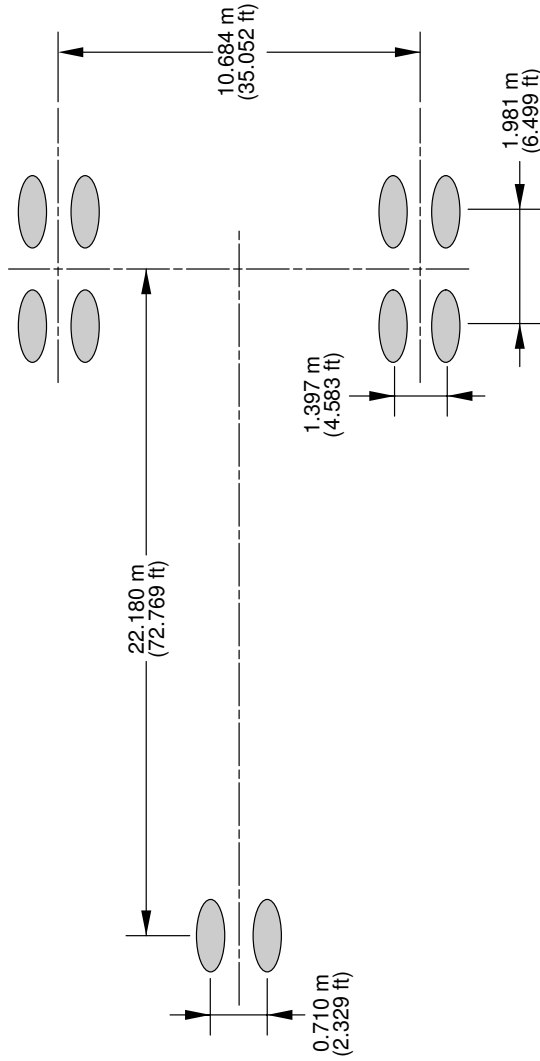

WEIGHT VARIANT	MAXIMUM RAMP WEIGHT	PERCENTAGE OF WEIGHT ON MAIN GEAR GROUP	NOSE GEAR TIRE SIZE	NOSE GEAR TIRE PRESSURE	MAIN GEAR TIRE SIZE	MAIN GEAR TIRE PRESSURE
A330-200F WV000	233 900 kg (515 650 lb)	94.6%	1050x395R16	12.7 bar (184 psi)	1400x530R23	14.2 bar (206 psi)
A330-200F WV001	227 900 kg (502 425 lb)	94.7%	1050x395R16	12.7 bar (184 psi)	1400x530R23	14.2 bar (206 psi)
A330-200F WV002	233 900 kg (515 650 lb)	94.6%	1050x395R16	12.7 bar (184 psi)	1400x530R23	14.2 bar (206 psi)

F_AC_070200_1_0170101_01_04

Landing Gear Footprint
FIGURE-7-2-0-991-017-A01

****ON A/C A330-300**

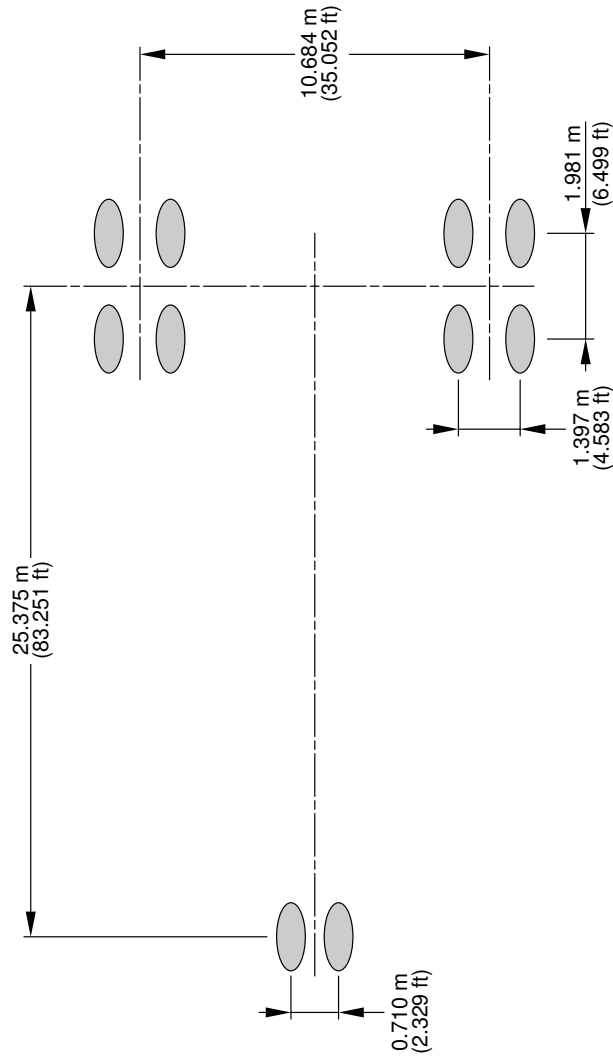

WEIGHT VARIANT	MAXIMUM RAMP WEIGHT	PERCENTAGE OF WEIGHT ON MAIN GEAR GROUP	NOSE GEAR TIRE SIZE	NOSE GEAR TIRE PRESSURE	MAIN GEAR TIRE SIZE	MAIN GEAR TIRE PRESSURE
A330-300 WV000	212 900 kg (469 375 lb)	94.9%	1050x395R16	10.7 bar (155 psi)	1400x530R23 OR 54x21-23 (bias)	13.1 bar (190 psi)
A330-300 WV001	184 900 kg (407 625 lb)	95.9%	1050x395R16	10.7 bar (155 psi)	1400x530R23 OR 54x21-23 (bias)	13.1 bar (190 psi)
A330-300 WV002	212 900 kg (469 375 lb)	94.9%	1050x395R16	10.7 bar (155 psi)	1400x530R23 OR 54x21-23 (bias)	13.1 bar (190 psi)
A330-300 WV003	215 900 kg (475 975 lb)	94.4%	1050x395R16	10.9 bar (158 psi)	1400x530R23 OR 54x21-23 (bias)	13.3 bar (193 psi)
A330-300 WV004 (209)	209 900 kg (462 750 lb)	95.7%	1050x395R16	10.9 bar (158 psi)	1400x530R23 OR 54x21-23 (bias)	13.3 bar (193 psi)

F_AC_070200_1_0060101_01_05

Landing Gear Footprint
(Sheet 1 of 4)
FIGURE-7-2-0-991-006-A01

**ON A/C A330-300

WEIGHT VARIANT	MAXIMUM RAMP WEIGHT	PERCENTAGE OF WEIGHT ON MAIN GEAR GROUP	NOSE GEAR TIRE SIZE	NOSE GEAR TIRE PRESSURE	MAIN GEAR TIRE SIZE	MAIN GEAR TIRE PRESSURE
A330-300 WV004 (215)	215 900 kg (475 975 lb)	95.6%	1050x395R16	10.9 bar (158 psi)	1400x530R23 OR 54x21-23 (bias)	13.3 bar (193 psi)
A330-300 WV010 (CG 33.5%)	217 900 kg (480 375 lb)	94.0%	1050x395R16	10.9 bar (158 psi)	1400x530R23 OR 54x21-23 (bias)	13.3 bar (193 psi)
A330-300 WV010 (CG 39.13%)	217 900 kg (480 375 lb)	95.6%	1050x395R16	10.9 bar (158 psi)	1400x530R23 OR 54x21-23 (bias)	13.3 bar (193 psi)
A330-300 WV011	212 900 kg (469 375 lb)	95.7%	1050x395R16	10.9 bar (158 psi)	1400x530R23 OR 54x21-23 (bias)	13.3 bar (193 psi)
A330-300 WV012	218 900 kg (482 600 lb)	95.6%	1050x395R16	10.9 bar (158 psi)	1400x530R23 OR 54x21-23 (bias)	13.3 bar (193 psi)
A330-300 WV013	215 900 kg (475 975 lb)	95.6%	1050x395R16	10.9 bar (158 psi)	1400x530R23 OR 54x21-23 (bias)	13.3 bar (193 psi)
A330-300 WV014	205 900 kg (453 925 lb)	95.7%	1050x395R16	10.9 bar (158 psi)	1400x530R23 OR 54x21-23 (bias)	13.3 bar (193 psi)
A330-300 WV020	230 900 kg (509 050 lb)	95.5%	1050x395R16	11.4 bar (165 psi)	1400x530R23 OR 54x21-23 (bias)	14.2 bar (206 psi)
A330-300 WV022	233 900 kg (515 650 lb)	95.5%	1050x395R16	11.6 bar (168 psi)	1400x530R23 OR 54x21-23 (bias)	14.5 bar (210 psi)
A330-300 WV024	205 900 kg (453 925 lb)	95.7%	1050x395R16	11.4 bar (165 psi)	1400x530R23 OR 54x21-23 (bias)	14.2 bar (206 psi)
A330-300 WV025	217 900 kg (480 375 lb)	95.6%	1050x395R16	11.4 bar (165 psi)	1400x530R23 OR 54x21-23 (bias)	14.2 bar (206 psi)
A330-300 WV026	217 900 kg (480 375 lb)	95.6%	1050x395R16	11.4 bar (165 psi)	1400x530R23 OR 54x21-23 (bias)	14.2 bar (206 psi)
A330-300 WV027	198 900 kg (438 500 lb)	95.8%	1050x395R16	11.4 bar (165 psi)	1400x530R23 OR 54x21-23 (bias)	14.2 bar (206 psi)
A330-300 WV030 (CG 39.83%)	199 900 kg (440 700 lb)	95.8%	1050x395R16	11.6 bar (168 psi)	1400x530R23 OR 54x21-23 (bias)	14.5 bar (210 psi)
A330-300 WV030 (CG 39.81%)	199 900 kg (440 700 lb)	95.8%	1050x395R16	11.6 bar (168 psi)	1400x530R23 OR 54x21-23 (bias)	14.5 bar (210 psi)
A330-300 WV030 (CG 39.82%)	199 900 kg (440 700 lb)	95.8%	1050x395R16	11.6 bar (168 psi)	1400x530R23 OR 54x21-23 (bias)	14.5 bar (210 psi)
A330-300 WV031 (CG 39.83%)	199 900 kg (440 700 lb)	95.8%	1050x395R16	11.6 bar (168 psi)	1400x530R23 OR 54x21-23 (bias)	14.5 bar (210 psi)
A330-300 WV031 (CG 39.81%)	199 900 kg (440 700 lb)	95.8%	1050x395R16	11.6 bar (168 psi)	1400x530R23 OR 54x21-23 (bias)	14.5 bar (210 psi)

F_AC_070200_1_0060102_01_02

Landing Gear Footprint
(Sheet 2 of 4)
FIGURE-7-2-0-991-006-A01

**ON A/C A330-300

WEIGHT VARIANT	MAXIMUM RAMP WEIGHT	PERCENTAGE OF WEIGHT ON MAIN GEAR GROUP	NOSE GEAR TIRE SIZE	NOSE GEAR TIRE PRESSURE	MAIN GEAR TIRE SIZE	MAIN GEAR TIRE PRESSURE
A330-300 WV031 (CG 39.82%)	199 900 kg (440 700 lb)	95.8%	1050x395R16	11.6 bar (168 psi)	1400x530R23 OR 54x21-23 (bias)	14.5 bar (210 psi)
A330-300 WV032 (CG 40.17%)	190 900 kg (420 875 lb)	95.9%	1050x395R16	11.6 bar (168 psi)	1400x530R23 OR 54x21-23 (bias)	14.5 bar (210 psi)
A330-300 WV032 (CG 39.41%)	190 900 kg (420 875 lb)	95.7%	1050x395R16	11.6 bar (168 psi)	1400x530R23 OR 54x21-23 (bias)	14.5 bar (210 psi)
A330-300 WV032 (CG 39.39%)	190 900 kg (420 875 lb)	95.7%	1050x395R16	11.6 bar (168 psi)	1400x530R23 OR 54x21-23 (bias)	14.5 bar (210 psi)
A330-300 WV033 (CG 40.17%)	190 900 kg (420 875 lb)	95.9%	1050x395R16	11.6 bar (168 psi)	1400x530R23 OR 54x21-23 (bias)	14.5 bar (210 psi)
A330-300 WV033 (CG 39.41%)	190 900 kg (420 875 lb)	95.7%	1050x395R16	11.6 bar (168 psi)	1400x530R23 OR 54x21-23 (bias)	14.5 bar (210 psi)
A330-300 WV033 (CG 39.39%)	190 900 kg (420 875 lb)	95.7%	1050x395R16	11.6 bar (168 psi)	1400x530R23 OR 54x21-23 (bias)	14.5 bar (210 psi)
A330-300 WV034 (CG 39.58%)	205 900 kg (453 925 lb)	95.7%	1050x395R16	11.6 bar (168 psi)	1400x530R23 OR 54x21-23 (bias)	14.5 bar (210 psi)
A330-300 WV034 (CG 39.57%)	205 900 kg (453 925 lb)	95.7%	1050x395R16	11.6 bar (168 psi)	1400x530R23 OR 54x21-23 (bias)	14.5 bar (210 psi)
A330-300 WV035 (CG 39.58%)	205 900 kg (453 925 lb)	95.7%	1050x395R16	11.6 bar (168 psi)	1400x530R23 OR 54x21-23 (bias)	14.5 bar (210 psi)
A330-300 WV035 (CG 39.57%)	205 900 kg (453 925 lb)	95.7%	1050x395R16	11.6 bar (168 psi)	1400x530R23 OR 54x21-23 (bias)	14.5 bar (210 psi)
A330-300 WV039 (CG 39.13%)	217 900 kg (480 375 lb)	95.6%	1050x395R16	11.6 bar (168 psi)	1400x530R23 OR 54x21-23 (bias)	14.5 bar (210 psi)
A330-300 WV039 (CG 39.12%)	217 900 kg (480 375 lb)	95.6%	1050x395R16	11.6 bar (168 psi)	1400x530R23 OR 54x21-23 (bias)	14.5 bar (210 psi)
A330-300 WV050	230 900 kg (509 050 lb)	95.5%	1050x395R16	11.6 bar (168 psi)	1400x530R23 OR 54x21-23 (bias)	14.5 bar (210 psi)
A330-300 WV051	212 900 kg (469 375 lb)	95.7%	1050x395R16	11.6 bar (168 psi)	1400x530R23 OR 54x21-23 (bias)	14.5 bar (210 psi)
A330-300 WV052	233 900 kg (515 650 lb)	95.5%	1050x395R16	11.6 bar (168 psi)	1400x530R23 OR 54x21-23 (bias)	14.5 bar (210 psi)
A330-300 WV053	205 900 kg (453 925 lb)	95.7%	1050x395R16	11.6 bar (168 psi)	1400x530R23 OR 54x21-23 (bias)	14.5 bar (210 psi)
A330-300 WV054	235 900 kg (520 075 lb)	94.6%	1050x395R16	11.6 bar (168 psi)	1400x530R23 OR 54x21-23 (bias)	14.5 bar (210 psi)

F_AC_070200_1_0060103_01_01

Landing Gear Footprint
(Sheet 3 of 4)
FIGURE-7-2-0-991-006-A01

**ON A/C A330-300

WEIGHT VARIANT	MAXIMUM RAMP WEIGHT	PERCENTAGE OF WEIGHT ON MAIN GEAR GROUP	NOSE GEAR TIRE SIZE	NOSE GEAR TIRE PRESSURE	MAIN GEAR TIRE SIZE	MAIN GEAR TIRE PRESSURE
A330-300 WV055	235 900 kg (520 075 lb)	94.6%	1050x395R16	11.6 bar (168 psi)	1400x530R23 OR 54x21-23 (bias)	14.5 bar (210 psi)
A330-300 WV056	205 900 kg (453 925 lb)	95.7%	1050x395R16	11.6 bar (168 psi)	1400x530R23 OR 54x21-23 (bias)	14.5 bar (210 psi)
A330-300 WV057 (CG 38.93%)	184 900 kg (407 625 lb)	95.5%	1050x395R16	11.6 bar (168 psi)	1400x530R23 OR 54x21-23 (bias)	14.5 bar (210 psi)
A330-300 WV057 (CG 38.96%)	184 900 kg (407 625 lb)	95.5%	1050x395R16	11.6 bar (168 psi)	1400x530R23 OR 54x21-23 (bias)	14.5 bar (210 psi)
A330-300 WV057 (CG 39.23%)	184 900 kg (407 625 lb)	95.6%	1050x395R16	11.6 bar (168 psi)	1400x530R23 OR 54x21-23 (bias)	14.5 bar (210 psi)
A330-300 WV058	215 900 kg (475 975 lb)	95.6%	1050x395R16	11.6 bar (168 psi)	1400x530R23 OR 54x21-23 (bias)	14.5 bar (210 psi)
A330-300 WV059	217 900 kg (480 375 lb)	95.6%	1050x395R16	11.6 bar (168 psi)	1400x530R23 OR 54x21-23 (bias)	14.5 bar (210 psi)
A330-300 WV060	198 900 kg (438 500 lb)	95.8%	1050x395R16	11.6 bar (168 psi)	1400x530R23 OR 54x21-23 (bias)	14.5 bar (210 psi)
A330-300 WV080	238 900 kg (526 675 lb)	94.5%	1050x395R16	11.6 bar (168 psi)	1400x530R23	14.9 bar (216 psi)
A330-300 WV081	242 900 kg (535 500 lb)	93.8%	1050x395R16	11.6 bar (168 psi)	1400x530R23	14.9 bar (216 psi)
A330-300 WV082	242 900 kg (535 500 lb)	93.8%	1050x395R16	11.6 bar (168 psi)	1400x530R23	14.9 bar (216 psi)
A330-300 WV083	240 900 kg (531 100 lb)	94.2%	1050x395R16	11.6 bar (168 psi)	1400x530R23	14.9 bar (216 psi)

F_AC_070200_1_0060104_01_02

Landing Gear Footprint
(Sheet 4 of 4)
FIGURE-7-2-0-991-006-A01

****ON A/C A330-800**

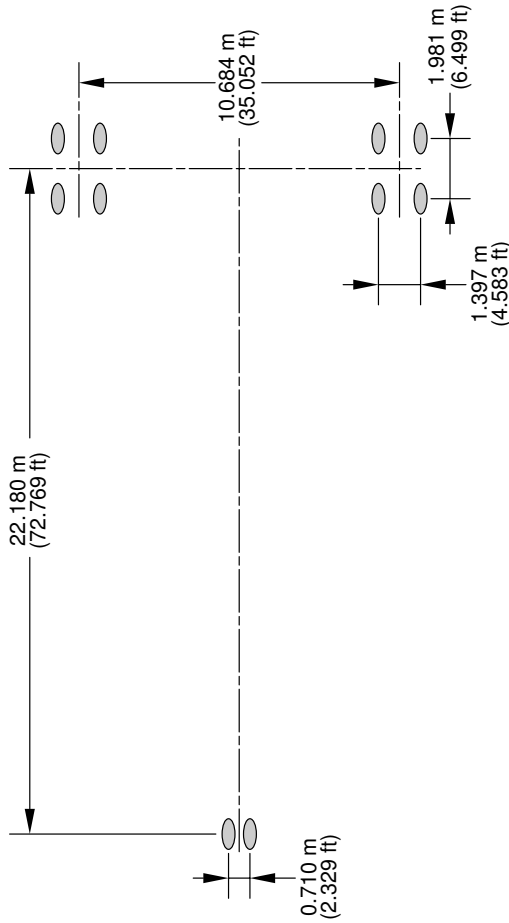

WEIGHT VARIANT	MAXIMUM RAMP WEIGHT	PERCENTAGE OF WEIGHT ON MAIN GEAR GROUP	NOSE GEAR TIRE SIZE	NOSE GEAR TIRE PRESSURE	MAIN GEAR TIRE SIZE	MAIN GEAR TIRE PRESSURE
A330-800 WV800	242 900 kg (535 500 lb)	92.6%	1050x395R16	12.7 bar (184 psi)	1400x530R23	14.7 bar (213 psi)
A330-800 WV801	242 900 kg (535 500 lb)	92.6%	1050x395R16	12.7 bar (184 psi)	1400x530R23	14.7 bar (213 psi)
A330-800 WV802	238 900 kg (526 675 lb)	93.5%	1050x395R16	12.7 bar (184 psi)	1400x530R23	14.7 bar (213 psi)
A330-800 WV803	234 900 kg (517 875 lb)	94.4%	1050x395R16	12.7 bar (184 psi)	1400x530R23	14.7 bar (213 psi)
A330-800 WV804	230 900 kg (509 050 lb)	94.7%	1050x395R16	12.7 bar (184 psi)	1400x530R23	14.7 bar (213 psi)
A330-800 WV805	220 900 kg (487 000 lb)	94.7%	1050x395R16	12.7 bar (184 psi)	1400x530R23	14.7 bar (213 psi)
A330-800 WV806	215 900 kg (475 975 lb)	94.8%	1050x395R16	12.7 bar (184 psi)	1400x530R23	14.7 bar (213 psi)
A330-800 WV807	210 900 kg (464 950 lb)	94.8%	1050x395R16	12.7 bar (184 psi)	1400x530R23	14.7 bar (213 psi)

F_AC_070200_1_0540101_01_02

Landing Gear Footprint
(Sheet 1 of 2)
FIGURE-7-2-0-991-054-A01

**ON A/C A330-800

WEIGHT VARIANT	MAXIMUM RAMP WEIGHT	PERCENTAGE OF WEIGHT ON MAIN GEAR GROUP	NOSE GEAR TIRE SIZE	NOSE GEAR TIRE PRESSURE	MAIN GEAR TIRE SIZE	MAIN GEAR TIRE PRESSURE
A330-800 WV808	205 900 kg (453 925 lb)	94.9%	1050x395R16	12.7 bar (184 psi)	1400x530R23	14.7 bar (213 psi)
A330-800 WV809	200 900 kg (442 900 lb)	94.9%	1050x395R16	12.7 bar (184 psi)	1400x530R23	14.7 bar (213 psi)
A330-800 WV820	251 900 kg (555 350 lb)	93.8%	1050x395R16	12.7 bar (184 psi)	1400x530R23	15.6 bar (226 psi)
A330-800 WV821	251 900 kg (555 350 lb)	93.8%	1050x395R16	12.7 bar (184 psi)	1400x530R23	15.6 bar (226 psi)
A330-800 WV822	247 900 kg (546 525 lb)	94.0%	1050x395R16	12.7 bar (184 psi)	1400x530R23	15.6 bar (226 psi)

F_AC_070200_1_0540102_01_00

Landing Gear Footprint
(Sheet 2 of 2)
FIGURE-7-2-0-991-054-A01

****ON A/C A330-900**

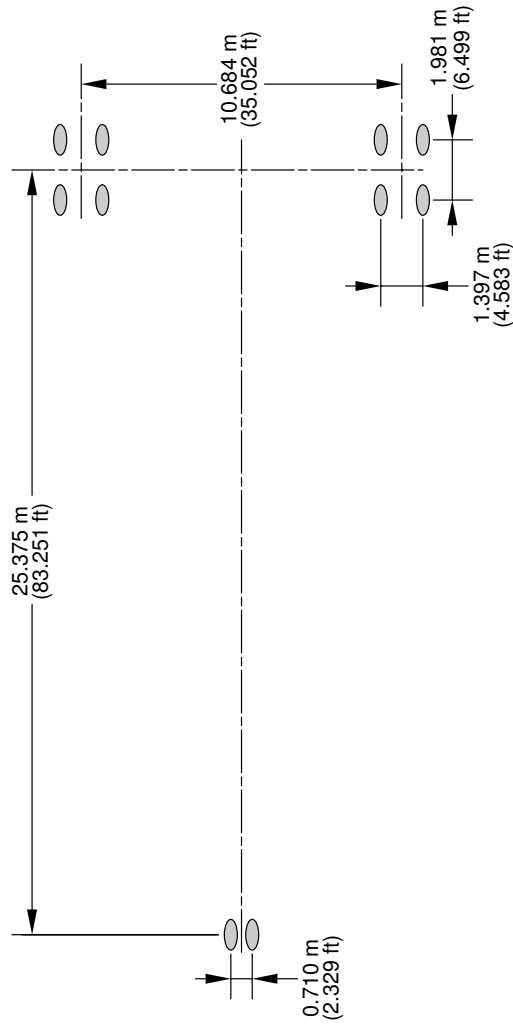

WEIGHT VARIANT	MAXIMUM RAMP WEIGHT	PERCENTAGE OF WEIGHT ON MAIN GEAR GROUP	NOSE GEAR TIRE SIZE	NOSE GEAR TIRE PRESSURE	MAIN GEAR TIRE SIZE	MAIN GEAR TIRE PRESSURE
A330-900 WV900	242 900 kg (535 500 lb)	93.8%	1050x395R16	11.6 bar (168 psi)	1400x530R23	14.9 bar (216 psi)
A330-900 WV901	242 900 kg (535 500 lb)	93.8%	1050x395R16	11.6 bar (168 psi)	1400x530R23	14.9 bar (216 psi)
A330-900 WV902	238 900 kg (526 675 lb)	94.5%	1050x395R16	11.6 bar (168 psi)	1400x530R23	14.9 bar (216 psi)
A330-900 WV903	234 900 kg (517 875 lb)	95.3%	1050x395R16	11.6 bar (168 psi)	1400x530R23	14.9 bar (216 psi)
A330-900 WV904	230 900 kg (509 050 lb)	95.5%	1050x395R16	11.6 bar (168 psi)	1400x530R23	14.9 bar (216 psi)
A330-900 WV905	220 900 kg (487 000 lb)	95.6%	1050x395R16	11.6 bar (168 psi)	1400x530R23	14.9 bar (216 psi)
A330-900 WV906	215 900 kg (475 975 lb)	95.6%	1050x395R16	11.6 bar (168 psi)	1400x530R23	14.9 bar (216 psi)
A330-900 WV907	210 900 kg (464 950 lb)	95.7%	1050x395R16	11.6 bar (168 psi)	1400x530R23	14.9 bar (216 psi)

F_AC_070200_1_0550101_01_02

Landing Gear Footprint
(Sheet 1 of 2)
FIGURE-7-2-0-991-055-A01

**ON A/C A330-900

WEIGHT VARIANT	MAXIMUM RAMP WEIGHT	PERCENTAGE OF WEIGHT ON MAIN GEAR GROUP	NOSE GEAR TIRE SIZE	NOSE GEAR TIRE PRESSURE	MAIN GEAR TIRE SIZE	MAIN GEAR TIRE PRESSURE
A330-900 WV908	205 900 kg (453 925 lb)	95.7%	1050x395R16	11.6 bar (168 psi)	1400x530R23	14.9 bar (216 psi)
A330-900 WV920	251 900 kg (555 350 lb)	93.9%	1050x395R16	11.6 bar (168 psi)	1400x530R23	15.6 bar (226 psi)
A330-900 WV921	251 900 kg (555 350 lb)	93.9%	1050x395R16	11.6 bar (168 psi)	1400x530R23	15.6 bar (226 psi)
A330-900 WV922	247 900 kg (546 525 lb)	94.2%	1050x395R16	11.6 bar (168 psi)	1400x530R23	15.6 bar (226 psi)

F_AC_070200_1_0550102_01_00

Landing Gear Footprint
(Sheet 2 of 2)
FIGURE-7-2-0-991-055-A01

7-3-0 Maximum Pavement Loads****ON A/C A330-200 A330-200F A330-300 A330-800 A330-900**Maximum Pavement Loads

1. This section gives maximum vertical and horizontal pavement loads for some critical conditions at the tire-ground interfaces.
The maximum pavement loads are given for all the operational weight variants of the aircraft.

****ON A/C A330-200**

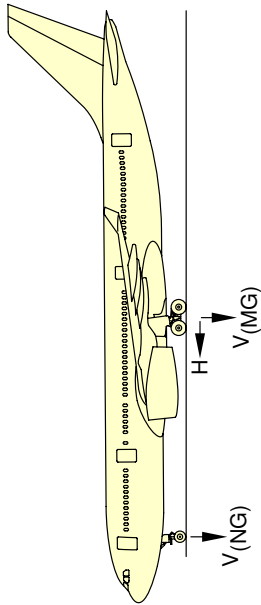

V(NG) MAXIMUM VERTICAL NOSE GEAR GROUND LOAD AT MOST FWD CG
 V(MG) MAXIMUM VERTICAL MAIN GEAR GROUND LOAD AT MAX AFT CG
 H MAXIMUM HORIZONTAL GROUND LOAD FROM BRAKING

1	2	3		4		5		6	
		V(NG)		V(MG)		V(MG) (PER STRUT)		H (PER STRUT)	
MODEL	MAXIMUM RAMP WEIGHT	STATIC LOAD AT MOST FWD CG	STATIC BRAKING AT 10 ft/s? DECELERATION	STATIC LOAD AT MAX AFT CG	STATIC BRAKING AT 10 ft/s? DECELERATION	STEADY BRAKING AT 10 ft/s? DECELERATION	AT INSTANTANEOUS BRAKING COEFFICIENT = 0.8		
A330-200 WV020	230 900 kg (509 050 lb)	25 170 kg (55 475 lb) 21% MAC (a)	39 570 kg (87 250 lb)	109 290 kg (240 950 lb)	37.5% MAC (a)	35 880 kg (79 100 lb)	87 430 kg (192 750 lb)		
A330-200 WV021	230 900 kg (509 050 lb)	25 170 kg (55 475 lb) 21% MAC (a)	39 570 kg (87 250 lb)	109 290 kg (240 950 lb)	37.5% MAC (a)	35 880 kg (79 100 lb)	87 430 kg (192 750 lb)		
A330-200 WV022	233 900 kg (515 650 lb)	25 170 kg (55 500 lb) 21.4% MAC (a)	39 750 kg (87 650 lb)	110 670 kg (244 000 lb)	37.4% MAC (a)	36 350 kg (80 125 lb)	88 540 kg (195 200 lb)		
A330-200 WV023	233 900 kg (515 650 lb)	25 170 kg (55 500 lb) 21.4% MAC (a)	39 750 kg (87 650 lb)	110 670 kg (244 000 lb)	37.4% MAC (a)	36 350 kg (80 125 lb)	88 540 kg (195 200 lb)		
A330-200 WV024	202 900 kg (447 325 lb)	24 220 kg (53 400 lb) 18% MAC (a)	36 990 kg (81 550 lb)	96 300 kg (212 300 lb)	38.4% MAC (a)	31 530 kg (69 850 lb)	77 040 kg (169 850 lb)		
A330-200 WV025	220 900 kg (487 000 lb)	25 160 kg (55 475 lb) 19.57% MAC (a)	38 980 kg (85 925 lb)	104 650 kg (230 725 lb)	37.79% MAC (a)	34 330 kg (75 675 lb)	83 720 kg (184 575 lb)		
A330-200 WV026	192 900 kg (425 275 lb)	23 050 kg (50 825 lb) 18% MAC (a)	35 240 kg (77 675 lb)	91 670 kg (202 100 lb)	38.8% MAC (a)	29 980 kg (66 100 lb)	73 330 kg (161 675 lb)		
A330-200 WV027	220 900 kg (487 000 lb)	25 160 kg (55 475 lb) 19.57% MAC (a)	38 980 kg (85 925 lb)	104 650 kg (230 725 lb)	37.79% MAC (a)	34 330 kg (75 675 lb)	83 720 kg (184 575 lb)		

NOTE:

- (a) LOADS CALCULATED USING AIRCRAFT AT MRW.
- (b) BRAKED MAIN GEAR.

F_AC_070300_1_0010101_01_05

Maximum Pavement Loads
(Sheet 1 of 3)

FIGURE-7-3-0-991-001-A01

**ON A/C A330-200

1	2	3		4		5		6	
		V (NG)		H (PER STRUT)		V (MG) (PER STRUT)		H (PER STRUT)	
MODEL	MAXIMUM RAMP WEIGHT	STATIC LOAD AT MOST FWD CG	STATIC BRAKING AT 10 ft/s? DECELERATION	STATIC LOAD AT MAX AFT CG	STATIC BRAKING AT 10 ft/s? DECELERATION	STATIC LOAD AT MAX AFT CG	STATIC BRAKING AT 10 ft/s? DECELERATION	AT INSTANTANEOUS BRAKING COEFFICIENT = 0.8	
A330-200 WV050	230 900 kg (509 050 lb)	25 170 kg (55 475 lb) 21% MAC (a)	39 570 kg (87 250 lb)	109 290 kg (240 950 lb) 37.5% MAC (a)	35 880 kg (79 100 lb)	109 290 kg (240 950 lb) 37.5% MAC (a)	35 880 kg (79 100 lb)	87 430 kg (192 750 lb)	(b)
A330-200 WV051	192 900 kg (425 275 lb)	23 050 kg (50 825 lb) 18% MAC (a)	35 240 kg (77 675 lb)	91 670 kg (202 100 lb) 38.8% MAC (a)	29 980 kg (66 100 lb)	91 670 kg (202 100 lb) 38.8% MAC (a)	29 980 kg (66 100 lb)	73 330 kg (161 675 lb)	(b)
A330-200 WV052	233 900 kg (515 650 lb)	25 170 kg (55 500 lb) 21.4% MAC (a)	39 750 kg (87 650 lb)	110 670 kg (244 000 lb) 37.4% MAC (a)	36 350 kg (80 125 lb)	110 670 kg (244 000 lb) 37.4% MAC (a)	36 350 kg (80 125 lb)	88 540 kg (195 200 lb)	(b)
A330-200 WV053	210 900 kg (464 950 lb)	25 150 kg (55 450 lb) 18% MAC (a)	38 390 kg (84 625 lb)	100 010 kg (220 475 lb) 38.1% MAC (a)	32 770 kg (72 250 lb)	100 010 kg (220 475 lb) 38.1% MAC (a)	32 770 kg (72 250 lb)	80 010 kg (176 375 lb)	(b)
A330-200 WV054	230 900 kg (509 050 lb)	25 170 kg (55 475 lb) 21% MAC (a)	39 570 kg (87 250 lb)	109 290 kg (240 950 lb) 37.5% MAC (a)	35 880 kg (79 100 lb)	109 290 kg (240 950 lb) 37.5% MAC (a)	35 880 kg (79 100 lb)	87 430 kg (192 750 lb)	(b)
A330-200 WV055	192 900 kg (425 275 lb)	23 050 kg (50 825 lb) 18% MAC (a)	35 240 kg (77 675 lb)	91 670 kg (202 100 lb) 38.8% MAC (a)	29 980 kg (66 100 lb)	91 670 kg (202 100 lb) 38.8% MAC (a)	29 980 kg (66 100 lb)	73 330 kg (161 675 lb)	(b)
A330-200 WV056	233 900 kg (515 650 lb)	25 170 kg (55 500 lb) 21.4% MAC (a)	39 750 kg (87 650 lb)	110 670 kg (244 000 lb) 37.4% MAC (a)	36 350 kg (80 125 lb)	110 670 kg (244 000 lb) 37.4% MAC (a)	36 350 kg (80 125 lb)	88 540 kg (195 200 lb)	(b)
A330-200 WV057	236 900 kg (522 275 lb)	25 170 kg (55 500 lb) 21.8% MAC (a)	39 910 kg (88 000 lb)	110 610 kg (243 875 lb) 33.7% MAC (a)	36 820 kg (81 175 lb)	110 610 kg (243 875 lb) 33.7% MAC (a)	36 820 kg (81 175 lb)	88 490 kg (195 100 lb)	(b)
A330-200 WV058	238 900 kg (526 675 lb)	25 170 kg (55 500 lb) 22.06% MAC (a)	40 020 kg (88 225 lb)	110 580 kg (243 775 lb) 31.3% MAC (a)	37 130 kg (81 850 lb)	110 580 kg (243 775 lb) 31.3% MAC (a)	37 130 kg (81 850 lb)	88 460 kg (195 025 lb)	(b)
A330-200 WV059	202 900 kg (447 325 lb)	24 230 kg (53 400 lb) 18% MAC (a)	36 990 kg (81 550 lb)	96 300 kg (212 300 lb) 38.4% MAC (a)	31 530 kg (69 525 lb)	96 300 kg (212 300 lb) 38.4% MAC (a)	31 530 kg (69 525 lb)	77 040 kg (169 850 lb)	(b)
A330-200 WV060	220 900 kg (487 000 lb)	25 140 kg (55 425 lb) 19.6% MAC (a)	38 960 kg (85 900 lb)	104 650 kg (230 725 lb) 37.8% MAC (a)	34 330 kg (75 675 lb)	104 650 kg (230 725 lb) 37.8% MAC (a)	34 330 kg (75 675 lb)	83 720 kg (184 575 lb)	(b)
A330-200 WV061	230 900 kg (509 050 lb)	25 170 kg (55 475 lb) 21% MAC (a)	39 570 kg (87 250 lb)	109 290 kg (240 950 lb) 37.5% MAC (a)	35 880 kg (79 100 lb)	109 290 kg (240 950 lb) 37.5% MAC (a)	35 880 kg (79 100 lb)	87 430 kg (192 750 lb)	(b)
A330-200 WV062	238 900 kg (526 675 lb)	25 170 kg (55 500 lb) 22.06% MAC (a)	40 020 kg (88 225 lb)	110 580 kg (243 775 lb) 31.3% MAC (a)	37 130 kg (81 850 lb)	110 580 kg (243 775 lb) 31.3% MAC (a)	37 130 kg (81 850 lb)	88 460 kg (195 025 lb)	(b)

NOTE:

- (a) LOADS CALCULATED USING AIRCRAFT AT MRW.
- (b) BRAKED MAIN GEAR.

F_AC_070300_1_0010107_01_04

Maximum Pavement Loads
(Sheet 2 of 3)

FIGURE-7-3-0-991-001-A01

**ON A/C A330-200

1	2	3		4	5		6	
		V (NG)			V (MG) (PER STRUT)		H (PER STRUT)	
MODEL	MAXIMUM RAMP WEIGHT	STATIC LOAD AT MOST FWD CG	STATIC BRAKING AT 10 ft/s? DECELERATION	STATIC LOAD AT MAX AFT CG	STEADY BRAKING AT 10 ft/s? DECELERATION	AT INSTANTANEOUS BRAKING COEFFICIENT = 0.8		
A330-200 WV063	192 900 kg (425 275 lb)	23 050 kg (50 825 lb) 18% MAC (a)	TBD	91 640 kg (202 050 lb) 38.73% MAC (a)	29 980 kg (66 100 lb) (b)	73 320 kg (161 625 lb) (b)		
A330-200 WV064	217 900 kg (480 375 lb)	25 160 kg (55 475 lb) 19.11% MAC (a)	TBD	103 250 kg (227 625 lb) 37.86% MAC (a)	33 860 kg (74 650 lb) (b)	82 600 kg (182 100 lb) (b)		
A330-200 WV080	238 900 kg (526 675 lb)	25 180 kg (55 500 lb) 22.05% MAC (a)	TBD	111 700 kg (246 250 lb) 34.07% MAC (a)	37 130 kg (81 850 lb) (b)	89 360 kg (197 000 lb) (b)		
A330-200 WV081	242 900 kg (535 500 lb)	25 190 kg (55 525 lb) 22.55% MAC (a)	TBD	112 510 kg (248 050 lb) 31.5% MAC (a)	37 750 kg (83 225 lb) (b)	90 010 kg (198 450 lb) (b)		
A330-200 WV082	242 900 kg (535 500 lb)	25 190 kg (55 525 lb) 22.55% MAC (a)	TBD	112 510 kg (248 050 lb) 31.5% MAC (a)	37 750 kg (83 225 lb) (b)	90 010 kg (198 450 lb) (b)		
A330-200 WV083	240 900 kg (531 100 lb)	25 180 kg (55 525 lb) 22.3% MAC (a)	TBD	112 110 kg (247 150 lb) 32.77% MAC (a)	37 440 kg (82 525 lb) (b)	89 680 kg (197 725 lb) (b)		

NOTE:
 (a) LOADS CALCULATED USING AIRCRAFT AT MRW.
 (b) BRAKED MAIN GEAR.

F_AC_070300_1_0010108_01_02

Maximum Pavement Loads
 (Sheet 3 of 3)
 FIGURE-7-3-0-991-001-A01

****ON A/C A330-200F**

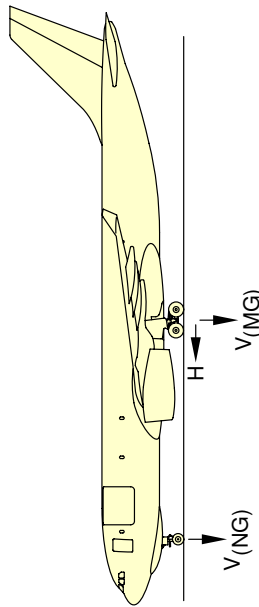

V(NG) MAXIMUM VERTICAL NOSE GEAR GROUND LOAD AT MOST FWD CG
 V(MG) MAXIMUM VERTICAL MAIN GEAR GROUND LOAD AT MAX AFT CG
 H MAXIMUM HORIZONTAL GROUND LOAD FROM BRAKING

1	2	3		4		5		6	
		V(NG)		V(MG)		H (PER STRUT)		H (PER STRUT)	
MODEL	MAXIMUM RAMP WEIGHT	STATIC LOAD AT MOST FWD CG	STATIC BRAKING AT 10 ft/s? DECELERATION	STATIC LOAD AT MAX AFT CG	STATIC BRAKING AT 10 ft/s? DECELERATION	STEADY BRAKING AT 10 ft/s? DECELERATION	AT INSTANTANEOUS BRAKING COEFFICIENT = 0.8		
A330-200F WV000	233 900 kg (515 650 lb)	25 170 kg (55 500 lb) 21.4% MAC (a)	39 750 kg (87 650 lb)	110 670 kg (244 000 lb) 37.4% MAC (a)	36 350 kg (80 125 lb)	88 540 kg (195 200 lb)	(b)		
A330-200F WV001	227 900 kg (502 425 lb)	25 150 kg (55 450 lb) 20.6% MAC (a)	39 380 kg (86 825 lb)	107 900 kg (237 875 lb) 37.6% MAC (a)	35 420 kg (78 075 lb)	86 320 kg (190 300 lb)	(b)		
A330-200F WV002	233 900 kg (515 650 lb)	25 170 kg (55 500 lb) 21.4% MAC (a)	39 750 kg (87 650 lb)	110 670 kg (244 000 lb) 37.4% MAC (a)	36 350 kg (80 125 lb)	88 540 kg (195 200 lb)	(b)		

NOTE:
 (a) LOADS CALCULATED USING AIRCRAFT AT MRW.
 (b) BRAKED MAIN GEAR.

F_AC_070300_1_0060101_01_05

Maximum Pavement Loads
 FIGURE-7-3-0-991-006-A01

****ON A/C A330-300**

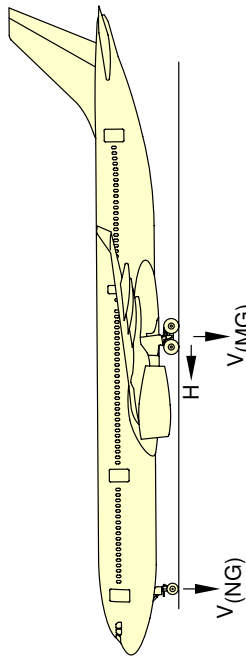

V(NG) MAXIMUM VERTICAL NOSE GEAR GROUND LOAD AT MOST FWD CG
 V(MG) MAXIMUM VERTICAL MAIN GEAR GROUND LOAD AT MAX AFT CG
 H MAXIMUM HORIZONTAL GROUND LOAD FROM BRAKING

1	2	3		4	5		6
		V(NG)			V(MG) (PER STRUT)		
MODEL	MAXIMUM RAMP WEIGHT	STATIC LOAD AT MOST FWD CG	15% MAC	STATIC BRAKING AT 10ft/s? DECELERATION	STATIC LOAD AT MAX AFT CG	36.5% MAC (a)	STEADY BRAKING AT INSTANTANEOUS DECELERATION AT 10ft/s? COEFFICIENT = 0.8
A330-300 WV000	212 900 kg (469 375 lb)	24 340 kg (53 650 lb)	15% MAC (a)	35 930 kg (79 200 lb)	100 970 kg (222 600 lb)	36.5% MAC (a)	33 090 kg (72 950 lb) (b)
A330-300 WV001	184 900 kg (407 625 lb)	21 200 kg (46 750 lb)	15% MAC (a)	31 370 kg (69 150 lb)	88 620 kg (195 375 lb)	40.1% MAC (a)	28 730 kg (63 350 lb) (b)
A330-300 WV002	212 900 kg (469 375 lb)	24 340 kg (53 650 lb)	15% MAC (a)	35 930 kg (79 200 lb)	100 970 kg (222 600 lb)	36.5% MAC (a)	33 090 kg (72 950 lb) (b)
A330-300 WV003	215 900 kg (475 975 lb)	24 670 kg (54 400 lb)	15% MAC (a)	36 410 kg (80 275 lb)	101 860 kg (224 575 lb)	34.8% MAC (a)	33 550 kg (73 975 lb) (b)
A330-300 WV004 (209)	209 900 kg (462 750 lb)	24 000 kg (52 925 lb)	15% MAC (a)	35 440 kg (78 125 lb)	100 430 kg (221 400 lb)	39.4% MAC (a)	32 620 kg (71 925 lb) (b)
A330-300 WV004 (215)	215 900 kg (475 975 lb)	24 670 kg (54 400 lb)	15% MAC (a)	36 410 kg (80 275 lb)	103 250 kg (227 625 lb)	39.2% MAC (a)	33 550 kg (73 975 lb) (b)
A330-300 WV010 (CG 33.5%)	217 900 kg (480 375 lb)	24 900 kg (54 900 lb)	15% MAC (a)	36 740 kg (81 000 lb)	102 390 kg (225 750 lb)	33.5% MAC (a)	33 860 kg (74 650 lb) (b)
A330-300 WV010 (CG 39.13%)	217 900 kg (480 375 lb)	24 900 kg (54 900 lb)	15% MAC (a)	36 740 kg (81 000 lb)	104 180 kg (229 675 lb)	39.13% MAC (a)	33 860 kg (74 650 lb) (b)

NOTE:
 (a) LOADS CALCULATED USING AIRCRAFT AT MRW.
 (b) BRAKED MAIN GEAR.

F_AC_070300_1_0030101_01_06

Maximum Pavement Loads
 (Sheet 1 of 5)
 FIGURE-7-3-0-991-003-A01

**ON A/C A330-300

1	2	3		4		5		6	
		V (NG)		H (PER STRUT)		V (MG) (PER STRUT)		H (PER STRUT)	
MODEL	MAXIMUM RAMP WEIGHT	STATIC LOAD AT MOST FWD CG	STATIC BRAKING AT 10 ft/s? DECELERATION	STATIC LOAD AT MAX AFT CG	STATIC BRAKING AT 10 ft/s? DECELERATION	STEADY BRAKING AT 10 ft/s? DECELERATION	STEADY BRAKING AT 10 ft/s? DECELERATION	AT INSTANTANEOUS BRAKING COEFFICIENT = 0.8	
A330-300 WV011	212 900 kg (469 375 lb)	15% MAC (a) 24 340 kg (53 650 lb)	35 930 kg (79 200 lb)	39.3% MAC (a) 101 840 kg (224 525 lb)	33 090 kg (72 950 lb)	81 470 kg (179 600 lb)			
A330-300 WV012	218 900 kg (482 600 lb)	15% MAC (a) 25 010 kg (55 150 lb)	36 900 kg (81 350 lb)	39.1% MAC (a) 104 650 kg (230 725 lb)	34 020 kg (75 000 lb)	83 720 kg (184 575 lb)			
A330-300 WV013	215 900 kg (475 975 lb)	15% MAC (a) 24 670 kg (54 400 lb)	36 410 kg (80 275 lb)	39.2% MAC (a) 103 250 kg (227 625 lb)	33 550 kg (73 975 lb)	82 600 kg (182 100 lb)			
A330-300 WV014	205 900 kg (453 925 lb)	15% MAC (a) 23 550 kg (51 925 lb)	34 790 kg (76 700 lb)	39.6% MAC (a) 98 570 kg (217 300 lb)	32 000 kg (70 550 lb)	78 860 kg (173 850 lb)			
A330-300 WV020	230 900 kg (509 050 lb)	18% MAC (a) 24 340 kg (53 675 lb)	36 840 kg (81 225 lb)	38.7% MAC (a) 110 270 kg (243 100 lb)	35 880 kg (79 100 lb)	88 220 kg (194 475 lb)			
A330-300 WV022	233 900 kg (515 650 lb)	18.4% MAC (a) 24 380 kg (53 750 lb)	37 030 kg (81 625 lb)	38.6% MAC (a) 111 670 kg (246 200 lb)	36 350 kg (80 125 lb)	89 340 kg (196 950 lb)			
A330-300 WV024	205 900 kg (453 925 lb)	15% MAC (a) 23 550 kg (51 925 lb)	34 790 kg (76 700 lb)	39.6% MAC (a) 98 570 kg (217 300 lb)	32 000 kg (70 550 lb)	78 860 kg (173 850 lb)			
A330-300 WV025	217 900 kg (480 375 lb)	16.11% MAC (a) 24 190 kg (53 350 lb)	36 030 kg (79 450 lb)	39.12% MAC (a) 104 180 kg (229 675 lb)	33 860 kg (74 650 lb)	83 340 kg (183 750 lb)			
A330-300 WV026	217 900 kg (480 375 lb)	16.11% MAC (a) 24 190 kg (53 350 lb)	TBD	39.13% MAC (a) 104 180 kg (229 675 lb)	33 860 kg (74 650 lb)	83 350 kg (183 750 lb)			
A330-300 WV027	198 900 kg (438 500 lb)	15% MAC (a) 22 770 kg (50 200 lb)	TBD	39.85% MAC (a) 95 280 kg (210 050 lb)	30 910 kg (68 150 lb)	76 220 kg (168 050 lb)			
A330-300 WV030 (CG 39.83%)	199 900 kg (440 700 lb)	15% MAC (a) 22 880 kg (50 450 lb)	TBD	39.83% MAC (a) 95 750 kg (211 100 lb)	31 070 kg (68 500 lb)	76 600 kg (168 875 lb)			
A330-300 WV030 (CG 39.81%)	199 900 kg (440 700 lb)	15% MAC (a) 22 880 kg (50 450 lb)	TBD	39.81% MAC (a) 95 750 kg (211 100 lb)	31 070 kg (68 500 lb)	76 600 kg (168 875 lb)			
A330-300 WV030 (CG 39.82%)	199 900 kg (440 700 lb)	15% MAC (a) 22 880 kg (50 450 lb)	TBD	39.82% MAC (a) 95 750 kg (211 100 lb)	31 070 kg (68 500 lb)	76 600 kg (168 875 lb)			

NOTE:

(a) LOADS CALCULATED USING AIRCRAFT AT MRW.

(b) BRAKED MAIN GEAR.

F_AC_070300_1_0030102_01_04

Maximum Pavement Loads
(Sheet 2 of 5)

FIGURE-7-3-0-991-003-A01

**ON A/C A330-300

1	2	3		4		5		6	
		V(NG)		H (PER STRUT)		V(MG)(PER STRUT)		H (PER STRUT)	
MODEL	MAXIMUM RAMP WEIGHT	STATIC LOAD AT MOST FWD CG	STATIC BRAKING AT 10 ft/s? DECELERATION	STATIC LOAD AT MAX AFT CG	STEADY BRAKING AT 10 ft/s? DECELERATION	AT INSTANTANEOUS BRAKING COEFFICIENT = 0.8	STATIC LOAD AT MOST FWD CG	STATIC BRAKING AT 10 ft/s? DECELERATION	AT INSTANTANEOUS BRAKING COEFFICIENT = 0.8
A330-300 WV031 (CG 39.83%)	199 900 kg (440 700 lb)	22 880 kg (50 450 lb) 15% MAC (a)	TBD	95 750 kg (211 100 lb) 39.83% MAC (a)	31 070 kg (68 500 lb) (b)	76 600 kg (168 875 lb) (b)	95 750 kg (211 100 lb) 39.81% MAC (a)	31 070 kg (68 500 lb) (b)	76 600 kg (168 875 lb) (b)
A330-300 WV031 (CG 39.81%)	199 900 kg (440 700 lb)	22 880 kg (50 450 lb) 15% MAC (a)	TBD	95 750 kg (211 100 lb) 39.82% MAC (a)	31 070 kg (68 500 lb) (b)	76 600 kg (168 875 lb) (b)	95 750 kg (211 100 lb) 39.82% MAC (a)	31 070 kg (68 500 lb) (b)	76 600 kg (168 875 lb) (b)
A330-300 WV031 (CG 39.82%)	199 900 kg (440 700 lb)	22 880 kg (50 450 lb) 15% MAC (a)	TBD	95 750 kg (211 100 lb) 40.17% MAC (a)	29 670 kg (65 400 lb) (b)	73 220 kg (161 425 lb) (b)	95 750 kg (211 100 lb) 39.41% MAC (a)	29 670 kg (65 400 lb) (b)	73 050 kg (161 050 lb) (b)
A330-300 WV032 (CG 40.17%)	190 900 kg (420 875 lb)	21 870 kg (48 225 lb) 15% MAC (a)	TBD	91 530 kg (201 775 lb) 39.39% MAC (a)	29 670 kg (65 400 lb) (b)	73 050 kg (161 050 lb) (b)	91 530 kg (201 775 lb) 40.17% MAC (a)	29 670 kg (65 400 lb) (b)	73 220 kg (161 425 lb) (b)
A330-300 WV032 (CG 39.41%)	190 900 kg (420 875 lb)	21 870 kg (48 225 lb) 15% MAC (a)	TBD	91 530 kg (201 775 lb) 39.41% MAC (a)	29 670 kg (65 400 lb) (b)	73 050 kg (161 050 lb) (b)	91 530 kg (201 775 lb) 39.39% MAC (a)	29 670 kg (65 400 lb) (b)	73 050 kg (161 050 lb) (b)
A330-300 WV033 (CG 40.17%)	190 900 kg (420 875 lb)	21 870 kg (48 225 lb) 15% MAC (a)	TBD	91 530 kg (201 775 lb) 39.41% MAC (a)	29 670 kg (65 400 lb) (b)	73 050 kg (161 050 lb) (b)	91 530 kg (201 775 lb) 40.17% MAC (a)	29 670 kg (65 400 lb) (b)	73 220 kg (161 425 lb) (b)
A330-300 WV033 (CG 39.41%)	190 900 kg (420 875 lb)	21 870 kg (48 225 lb) 15% MAC (a)	TBD	91 530 kg (201 775 lb) 39.41% MAC (a)	29 670 kg (65 400 lb) (b)	73 050 kg (161 050 lb) (b)	91 530 kg (201 775 lb) 39.41% MAC (a)	29 670 kg (65 400 lb) (b)	73 050 kg (161 050 lb) (b)
A330-300 WV033 (CG 39.39%)	190 900 kg (420 875 lb)	21 870 kg (48 225 lb) 15% MAC (a)	TBD	91 530 kg (201 775 lb) 39.39% MAC (a)	29 670 kg (65 400 lb) (b)	73 050 kg (161 050 lb) (b)	91 530 kg (201 775 lb) 39.39% MAC (a)	29 670 kg (65 400 lb) (b)	73 050 kg (161 050 lb) (b)
A330-300 WV034 (CG 39.58%)	205 900 kg (453 925 lb)	23 550 kg (51 925 lb) 15% MAC (a)	TBD	98 560 kg (217 300 lb) 39.57% MAC (a)	32 000 kg (70 550 lb) (b)	78 850 kg (173 825 lb) (b)	98 560 kg (217 300 lb) 39.58% MAC (a)	32 000 kg (70 550 lb) (b)	78 850 kg (173 825 lb) (b)
A330-300 WV034 (CG 39.57%)	205 900 kg (453 925 lb)	23 550 kg (51 925 lb) 15% MAC (a)	TBD	98 560 kg (217 300 lb) 39.57% MAC (a)	32 000 kg (70 550 lb) (b)	78 850 kg (173 825 lb) (b)	98 560 kg (217 300 lb) 39.57% MAC (a)	32 000 kg (70 550 lb) (b)	78 850 kg (173 825 lb) (b)
A330-300 WV035 (CG 39.58%)	205 900 kg (453 925 lb)	23 550 kg (51 925 lb) 15% MAC (a)	TBD	98 560 kg (217 300 lb) 39.57% MAC (a)	32 000 kg (70 550 lb) (b)	78 850 kg (173 825 lb) (b)	98 560 kg (217 300 lb) 39.58% MAC (a)	32 000 kg (70 550 lb) (b)	78 850 kg (173 825 lb) (b)
A330-300 WV035 (CG 39.57%)	205 900 kg (453 925 lb)	23 550 kg (51 925 lb) 15% MAC (a)	TBD	98 560 kg (217 300 lb) 39.57% MAC (a)	32 000 kg (70 550 lb) (b)	78 850 kg (173 825 lb) (b)	98 560 kg (217 300 lb) 39.57% MAC (a)	32 000 kg (70 550 lb) (b)	78 850 kg (173 825 lb) (b)

NOTE:

(a) LOADS CALCULATED USING AIRCRAFT AT MRW.

(b) BRAKED MAIN GEAR.

F_AC_070300_1_0030103_01_02

Maximum Pavement Loads
(Sheet 3 of 5)

FIGURE-7-3-0-991-003-A01

**ON A/C A330-300

1	2	3		4		5		6	
		V(NG)		H(PER STRUT)		V(MG)(PER STRUT)		H(PER STRUT)	
MODEL	MAXIMUM RAMP WEIGHT	STATIC LOAD AT MOST FWD CG	STATIC BRAKING AT 10 ft/s? DECELERATION	STATIC LOAD AT MAX AFT CG	STATIC BRAKING AT 10 ft/s? DECELERATION	STATIC LOAD AT MAX AFT CG	STATIC BRAKING AT 10 ft/s? DECELERATION	AT INSTANTANEOUS BRAKING COEFFICIENT = 0.8	
A330-300 WV039 (CG 39.13%)	217 900 kg (480 375 lb)	24 190 kg (53 350 lb) 16.11% MAC (a)	TBD	104 180 kg (229 675 lb) 39.13% MAC (a)	33 860 kg (74 650 lb) (b)	83 350 kg (183 750 lb) (b)			
A330-300 WV039 (CG 39.12%)	217 900 kg (480 375 lb)	24 190 kg (53 350 lb) 16.11% MAC (a)	TBD	104 180 kg (229 675 lb) 39.12% MAC (a)	33 860 kg (74 650 lb) (b)	83 340 kg (183 750 lb) (b)			
A330-300 WV050	230 900 kg (509 050 lb)	24 340 kg (53 675 lb) 18% MAC (a)	36 840 kg (81 225 lb)	110 270 kg (243 100 lb) 38.7% MAC (a)	35 880 kg (79 100 lb) (b)	88 220 kg (194 475 lb) (b)			
A330-300 WV051	212 900 kg (469 375 lb)	24 130 kg (53 200 lb) 15.33% MAC (a)	35 720 kg (78 750 lb)	101 830 kg (224 500 lb) 39.29% MAC (a)	33 090 kg (72 950 lb) (b)	81 470 kg (179 600 lb) (b)			
A330-300 WV052	233 900 kg (515 650 lb)	24 380 kg (53 750 lb) 18.4% MAC (a)	37 030 kg (81 625 lb)	111 670 kg (246 200 lb) 38.6% MAC (a)	36 350 kg (80 125 lb) (b)	89 340 kg (196 950 lb) (b)			
A330-300 WV053	205 900 kg (453 925 lb)	23 550 kg (51 925 lb) 15% MAC (a)	34 790 kg (76 700 lb)	98 570 kg (217 300 lb) 39.6% MAC (a)	32 000 kg (70 550 lb) (b)	78 860 kg (173 850 lb) (b)			
A330-300 WV054	235 900 kg (520 075 lb)	24 380 kg (53 750 lb) 18.7% MAC (a)	37 130 kg (81 850 lb)	111 640 kg (246 125 lb) 35.7% MAC (a)	36 660 kg (80 825 lb) (b)	89 310 kg (196 900 lb) (b)			
A330-300 WV055	235 900 kg (520 075 lb)	24 380 kg (53 750 lb) 18.7% MAC (a)	37 130 kg (81 850 lb)	111 640 kg (246 125 lb) 35.7% MAC (a)	36 660 kg (80 825 lb) (b)	89 310 kg (196 900 lb) (b)			
A330-300 WV056	205 900 kg (453 925 lb)	23 550 kg (51 925 lb) 15% MAC (a)	34 790 kg (76 700 lb)	98 560 kg (217 300 lb) 39.57% MAC (a)	32 000 kg (70 550 lb) (b)	78 850 kg (173 825 lb) (b)			
A330-300 WV057 (CG 38.93%)	184 900 kg (407 625 lb)	21 200 kg (46 750 lb) 15% MAC (a)	TBD	88 310 kg (194 675 lb) 38.93% MAC (a)	28 730 kg (63 350 lb) (b)	70 640 kg (155 750 lb) (b)			
A330-300 WV057 (CG 38.96%)	184 900 kg (407 625 lb)	21 200 kg (46 750 lb) 15% MAC (a)	TBD	88 310 kg (194 700 lb) 38.96% MAC (a)	28 730 kg (63 350 lb) (b)	70 650 kg (155 750 lb) (b)			
A330-300 WV057 (CG 39.23%)	184 900 kg (407 625 lb)	21 200 kg (46 750 lb) 15% MAC (a)	TBD	88 390 kg (194 850 lb) 39.23% MAC (a)	28 730 kg (63 350 lb) (b)	70 710 kg (155 875 lb) (b)			
A330-300 WV058	215 900 kg (475 975 lb)	24 170 kg (53 275 lb) 15.81% MAC (a)	TBD	103 250 kg (227 625 lb) 39.2% MAC (a)	33 550 kg (73 975 lb) (b)	82 600 kg (182 100 lb) (b)			

NOTE:

- (a) LOADS CALCULATED USING AIRCRAFT AT MRW.
- (b) BRAKED MAIN GEAR.

F_AC_070300_1_0030104_01_01

Maximum Pavement Loads
(Sheet 4 of 5)
FIGURE-7-3-0-991-003-A01

**ON A/C A330-300

1	2	3		4		5		6	
		V (NG)		H (PER STRUT)		V (MG) (PER STRUT)		H (PER STRUT)	
MODEL	MAXIMUM RAMP WEIGHT	STATIC LOAD AT MOST FWD CG	STATIC BRAKING AT 10 ft/s? DECELERATION	STATIC LOAD AT MAX AFT CG	STATIC BRAKING AT 10 ft/s? DECELERATION	STATIC LOAD AT MAX AFT CG	STATIC BRAKING AT 10 ft/s? DECELERATION	STEADY BRAKING AT 10 ft/s? DECELERATION	AT INSTANTANEOUS BRAKING COEFFICIENT = 0.8
A330-300 WV059	217 900 kg (480 375 lb)	24 190 kg (53 350 lb) 16.11% MAC (a)	TBD	104 180 kg (229 675 lb) 39.13% MAC (a)	TBD	104 180 kg (229 675 lb) 39.13% MAC (a)	33 860 kg (74 650 lb) (b)	33 860 kg (74 650 lb) (b)	83 350 kg (183 750 lb) (b)
A330-300 WV060	198 900 kg (438 500 lb)	22 770 kg (50 200 lb) 15% MAC (a)	TBD	95 280 kg (210 050 lb) 39.85% MAC (a)	TBD	95 280 kg (210 050 lb) 39.85% MAC (a)	30 910 kg (68 150 lb) (b)	30 910 kg (68 150 lb) (b)	76 220 kg (168 050 lb) (b)
A330-300 WV080	238 900 kg (526 675 lb)	24 400 kg (53 800 lb) 19.1% MAC (a)	TBD	112 920 kg (248 950 lb) 35.29% MAC (a)	TBD	112 920 kg (248 950 lb) 35.29% MAC (a)	37 130 kg (81 850 lb) (b)	37 130 kg (81 850 lb) (b)	90 330 kg (199 150 lb) (b)
A330-300 WV081	242 900 kg (535 500 lb)	24 440 kg (53 900 lb) 19.61% MAC (a)	TBD	113 900 kg (251 100 lb) 32.73% MAC (a)	TBD	113 900 kg (251 100 lb) 32.73% MAC (a)	37 750 kg (83 225 lb) (b)	37 750 kg (83 225 lb) (b)	91 120 kg (200 875 lb) (b)
A330-300 WV082	242 900 kg (535 500 lb)	24 440 kg (53 900 lb) 19.61% MAC (a)	TBD	113 900 kg (251 100 lb) 32.73% MAC (a)	TBD	113 900 kg (251 100 lb) 32.73% MAC (a)	37 750 kg (83 225 lb) (b)	37 750 kg (83 225 lb) (b)	91 120 kg (200 875 lb) (b)
A330-300 WV083	240 900 kg (531 100 lb)	24 420 kg (53 850 lb) 19.36% MAC (a)	TBD	113 410 kg (250 025 lb) 34% MAC (a)	TBD	113 410 kg (250 025 lb) 34% MAC (a)	37 440 kg (82 525 lb) (b)	37 440 kg (82 525 lb) (b)	90 730 kg (200 025 lb) (b)

NOTE:
 (a) LOADS CALCULATED USING AIRCRAFT AT MRW.
 (b) BRAKED MAIN GEAR.

F_AC_070300_1_0030105_01_02

Maximum Pavement Loads
 (Sheet 5 of 5)
 FIGURE-7-3-0-991-003-A01

****ON A/C A330-800**

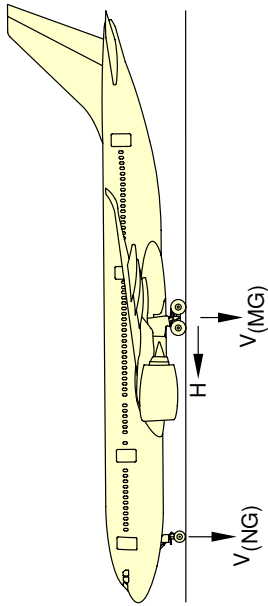

V(NG) MAXIMUM VERTICAL NOSE GEAR GROUND LOAD AT MOST FWD CG
 V(MG) MAXIMUM VERTICAL MAIN GEAR GROUND LOAD AT MAX AFT CG
 H MAXIMUM HORIZONTAL GROUND LOAD FROM BRAKING

1	2	3		4	5		6
		V(NG)			V(MG) (PER STRUT)		
MODEL	MAXIMUM RAMP WEIGHT	STATIC LOAD AT MOST FWD CG	STATIC BRKING AT 10ft/s? DECELERATION	STATIC BRKING AT 10ft/s? DECELERATION	STATIC LOAD AT MAX AFT CG	STATIC BRKING AT INSTANTANEOUS BRAKING COEFFICIENT = 0.8	H (PER STRUT)
A330-800 WV800	242 900 kg (535 500 lb)	25 190 kg (55 525 lb) 22.55% MAC (a)	TBD	TBD	112 510 kg (248 050 lb) 31.5% MAC (a)	37 750 kg (83 225 lb) (b)	90 010 kg (198 450 lb) (b)
A330-800 WV801	242 900 kg (535 500 lb)	25 190 kg (55 525 lb) 22.55% MAC (a)	TBD	TBD	112 510 kg (248 050 lb) 31.5% MAC (a)	37 750 kg (83 225 lb) (b)	90 010 kg (198 450 lb) (b)
A330-800 WV802	238 900 kg (526 675 lb)	25 180 kg (55 500 lb) 22.05% MAC (a)	TBD	TBD	111 700 kg (246 250 lb) 34.07% MAC (a)	37 130 kg (81 850 lb) (b)	89 360 kg (197 000 lb) (b)
A330-800 WV803	234 900 kg (517 875 lb)	25 180 kg (55 500 lb) 21.53% MAC (a)	TBD	TBD	110 880 kg (244 450 lb) 36.72% MAC (a)	36 500 kg (80 475 lb) (b)	88 700 kg (195 550 lb) (b)
A330-800 WV804	230 900 kg (509 050 lb)	25 180 kg (55 500 lb) 20.99% MAC (a)	TBD	TBD	109 280 kg (240 925 lb) 37.48% MAC (a)	35 880 kg (79 100 lb) (b)	87 420 kg (192 750 lb) (b)
A330-800 WV805	220 900 kg (487 000 lb)	25 170 kg (55 475 lb) 19.56% MAC (a)	TBD	TBD	104 640 kg (230 700 lb) 37.77% MAC (a)	34 330 kg (75 675 lb) (b)	83 710 kg (184 550 lb) (b)
A330-800 WV806	215 900 kg (475 975 lb)	25 160 kg (55 475 lb) 18.8% MAC (a)	TBD	TBD	102 330 kg (225 600 lb) 37.93% MAC (a)	33 550 kg (73 975 lb) (b)	81 860 kg (180 475 lb) (b)
A330-800 WV807	210 900 kg (464 950 lb)	25 150 kg (55 450 lb) 18% MAC (a)	TBD	TBD	100 000 kg (220 475 lb) 38.09% MAC (a)	32 770 kg (72 250 lb) (b)	80 000 kg (176 375 lb) (b)

NOTE:

- (a) LOADS CALCULATED USING AIRCRAFT AT MRW.
- (b) BRAKED MAIN GEAR.

F_AC_070300_1_0200101_01_02

Maximum Pavement Loads
(Sheet 1 of 2)

FIGURE-7-3-0-991-020-A01

**ON A/C A330-800

1	2	3		4		5		6	
		V (NG)		H (PER STRUT)		V (MG) (PER STRUT)		H (PER STRUT)	
MODEL	MAXIMUM RAMP WEIGHT	STATIC LOAD AT MOST FWD CG	STATIC BRAKING AT 10 ft/s? DECELERATION	STATIC LOAD AT MAX AFT CG	STEADY BRAKING AT 10 ft/s? DECELERATION	STEADY BRAKING AT 10 ft/s? DECELERATION	AT INSTANTANEOUS BRAKING COEFFICIENT = 0.8		
A330-800 WV808	205 900 kg (453 925 lb)	18% MAC (a) 24 570 kg (54 175 lb)	TBD	38.26% MAC (a) 97 680 kg (215 350 lb)	32 000 kg (70 550 lb)	32 000 kg (70 550 lb)	78 150 kg (172 275 lb)	(b)	(b)
A330-800 WV809	200 900 kg (442 900 lb)	18% MAC (a) 23 990 kg (52 875 lb)	TBD	38.44% MAC (a) 95 360 kg (210 250 lb)	31 220 kg (68 825 lb)	31 220 kg (68 825 lb)	76 290 kg (168 200 lb)	(b)	(b)
A330-800 WV820	251 900 kg (555 350 lb)	23.62% MAC (a) 25 200 kg (55 550 lb)	TBD	35% MAC (a) 118 190 kg (260 550 lb)	39 150 kg (86 300 lb)	39 150 kg (86 300 lb)	94 550 kg (208 450 lb)	(b)	(b)
A330-800 WV821	251 900 kg (555 350 lb)	23.62% MAC (a) 25 200 kg (55 550 lb)	TBD	35% MAC (a) 118 190 kg (260 550 lb)	39 150 kg (86 300 lb)	39 150 kg (86 300 lb)	94 550 kg (208 450 lb)	(b)	(b)
A330-800 WV822	247 900 kg (546 525 lb)	23.15% MAC (a) 25 190 kg (55 550 lb)	TBD	35.5% MAC (a) 116 520 kg (256 875 lb)	38 520 kg (84 925 lb)	38 520 kg (84 925 lb)	93 210 kg (205 500 lb)	(b)	(b)

NOTE:
 (a) LOADS CALCULATED USING AIRCRAFT AT MRW.
 (b) BRAKED MAIN GEAR.

F_AC_070300_1_0200102_01_00

Maximum Pavement Loads
 (Sheet 2 of 2)
 FIGURE-7-3-0-991-020-A01

****ON A/C A330-900**

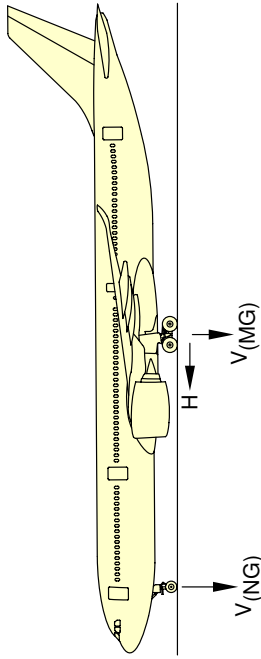

V(NG) MAXIMUM VERTICAL NOSE GEAR GROUND LOAD AT MOST FWD CG
 V(MG) MAXIMUM VERTICAL MAIN GEAR GROUND LOAD AT MAX AFT CG
 H MAXIMUM HORIZONTAL GROUND LOAD FROM BRAKING

1	2	3		4	5		6
MODEL	MAXIMUM RAMP WEIGHT	V(NG)		STATIC BRAKING AT 10 ft/s? DECELERATION	V(MG) (PER STRUT)		H (PER STRUT)
		STATIC LOAD AT MOST FWD CG	STATIC LOAD AT MAX AFT CG		STATIC LOAD AT MAX AFT CG	STEADY BRAKING AT 10 ft/s? DECELERATION	AT INSTANTANEOUS BRAKING COEFFICIENT = 0.8
A330-900 WV900	242 900 kg (535 500 lb)	19.61% MAC (a)	113 900 kg (251 100 lb)	TBD	113 900 kg (251 100 lb)	32.73% MAC (a)	91 120 kg (200 875 lb) (b)
A330-900 WV901	242 900 kg (535 500 lb)	19.61% MAC (a)	113 900 kg (251 100 lb)	TBD	113 900 kg (251 100 lb)	32.73% MAC (a)	91 120 kg (200 875 lb) (b)
A330-900 WV902	238 900 kg (526 675 lb)	19.1% MAC (a)	112 920 kg (248 950 lb)	TBD	112 920 kg (248 950 lb)	35.29% MAC (a)	90 330 kg (199 150 lb) (b)
A330-900 WV903	234 900 kg (517 875 lb)	18.58% MAC (a)	111 920 kg (246 750 lb)	TBD	111 920 kg (246 750 lb)	37.93% MAC (a)	89 540 kg (197 400 lb) (b)
A330-900 WV904	230 900 kg (509 050 lb)	18.03% MAC (a)	110 270 kg (243 100 lb)	TBD	110 270 kg (243 100 lb)	38.69% MAC (a)	88 210 kg (194 475 lb) (b)
A330-900 WV905	220 900 kg (487 000 lb)	16.58% MAC (a)	105 610 kg (232 825 lb)	TBD	105 610 kg (232 825 lb)	39.09% MAC (a)	84 490 kg (186 250 lb) (b)
A330-900 WV906	215 900 kg (475 975 lb)	15.81% MAC (a)	103 250 kg (227 625 lb)	TBD	103 250 kg (227 625 lb)	39.2% MAC (a)	82 600 kg (182 100 lb) (b)
A330-900 WV907	210 900 kg (464 950 lb)	15% MAC (a)	100 900 kg (222 450 lb)	TBD	100 900 kg (222 450 lb)	39.38% MAC (a)	80 720 kg (177 950 lb) (b)

NOTE:

- (a) LOADS CALCULATED USING AIRCRAFT AT MRW.
- (b) BRAKED MAIN GEAR.

F_AC_070300_1_0210101_01_02

Maximum Pavement Loads
 (Sheet 1 of 2)
 FIGURE-7-3-0-991-021-A01

**ON A/C A330-900

1	2	3		4	5		6	
		V (NG)			V (MG) (PER STRUT)		H (PER STRUT)	
MODEL	MAXIMUM RAMP WEIGHT	STATIC LOAD AT MOST FWD CG	STATIC BRAKING AT 10 ft/s? DECELERATION	STATIC LOAD AT MAX AFT CG	STATIC BRAKING AT 10 ft/s? DECELERATION	STEADY BRAKING AT 10 ft/s? DECELERATION	AT INSTANTANEOUS BRAKING COEFFICIENT = 0.8	
A330-900 WV908	205 900 kg (453 925 lb)	15% MAC (a) 23 550 kg (51 925 lb)	TBD	39.58% MAC (a) 98 560 kg (217 300 lb)	32 000 kg (70 550 lb)	78 850 kg (173 825 lb)	(b)	
A330-900 WV920	251 900 kg (555 350 lb)	20.69% MAC (a) 24 540 kg (54 100 lb)	TBD	33% MAC (a) 118 220 kg (260 625 lb)	39 150 kg (86 300 lb)	94 580 kg (208 500 lb)	(b)	
A330-900 WV921	251 900 kg (555 350 lb)	20.69% MAC (a) 24 540 kg (54 100 lb)	TBD	33% MAC (a) 118 220 kg (260 625 lb)	39 150 kg (86 300 lb)	94 580 kg (208 500 lb)	(b)	
A330-900 WV922	247 900 kg (546 525 lb)	20.22% MAC (a) 24 500 kg (54 000 lb)	TBD	34.17% MAC (a) 116 770 kg (257 425 lb)	38 520 kg (84 925 lb)	93 420 kg (205 950 lb)	(b)	

NOTE:
 (a) LOADS CALCULATED USING AIRCRAFT AT MRW.
 (b) BRAKED MAIN GEAR.

F_AC_070300_1_0210102_01_00

Maximum Pavement Loads
 (Sheet 2 of 2)
 FIGURE-7-3-0-991-021-A01

7-4-0 Landing Gear Loading on Pavement

****ON A/C A330-200 A330-200F A330-300 A330-800 A330-900**

Landing Gear Loading on Pavement

1. The curves related to the landing gear loading on pavement are not given in section 07-04-00. Because the relationship between the aircraft weight, the center of gravity and the landing gear loading on the pavement is not strictly linear, it cannot be shown in chart format. But you can find in section 07-03-00 the maximum vertical and horizontal pavement loads for some critical conditions at the tire/ground interfaces for all the operational weight variants of the aircraft. For questions related to the landing gear loading on pavement, contact Airbus.

7-5-0 Flexible Pavement Requirements - U.S. Army Corps of Engineers Design Method****ON A/C A330-200 A330-200F A330-300 A330-800 A330-900**Flexible Pavement Requirements - US Army Corps of Engineers Design Method

1. The flexible-pavement requirements curves by U.S. Army Corps of Engineers Design Method are not given in section 07-05-00 since the related data is available through free software. Sections 07-02-00 and 07-03-00 give all the inputs data required for the use of such software.

NOTE : The U.S. Army Corps of Engineers Design Method for flexible pavements is being gradually superseded by mechanistic-empirical design methods mostly relying on Linear Elastic Analysis (LEA). The number of parameters considered by such methods is not applicable for a chart format and the use of dedicated pavement-design software is necessary. For questions related to the flexible pavement requirements, contact Airbus.



7-6-0 Flexible Pavement Requirements - LCN Conversion

****ON A/C A330-200 A330-200F A330-300 A330-800 A330-900**

Flexible Pavement Requirements - LCN Conversion

1. The Load Classification Number (LCN) curves are no longer provided in section 07-06-00 since the LCN system for reporting pavement strength is obsolete, having been replaced by the ICAO recommended ACN/PCN system in 1983 and ACR/PCR system in 2020.
For questions related to the LCN system, contact Airbus.

7-7-0 Rigid Pavement Requirements - Portland Cement Association Design Method****ON A/C A330-200 A330-200F A330-300 A330-800 A330-900**Rigid Pavement Requirements - Portland Cement Association Design Method

1. The rigid-pavement requirements curves by Portland Cement Association Design Method are not given in section 07-07-00 since the related data is available through free software. Sections 07-02-00 and 07-03-00 give all the inputs data required for the use of such software.

NOTE : The Portland Cement Association Design Method for rigid pavements is being gradually superseded by mechanistic-empirical design methods mostly relying on Finite Element Analysis (FEM). The number of parameters considered by such methods is not applicable for a chart format and the use of dedicated pavement-design software is necessary. For questions related to the rigid pavement requirements, contact Airbus.

7-8-0 Rigid Pavement Requirements - LCN Conversion****ON A/C A330-200 A330-200F A330-300 A330-800 A330-900**Rigid Pavement Requirements - LCN Conversion

1. The Load Classification Number (LCN) curves are no longer provided in section 07-08-00 since the LCN system for reporting pavement strength is obsolete, having been replaced by the ICAO recommended ACN/PCN system in 1983 and ACR/PCR system in 2020.
For questions related to the LCN system, contact Airbus.

7-9-0 ACN/PCN Reporting System - Flexible and Rigid Pavements****ON A/C A330-200 A330-200F A330-300 A330-800 A330-900**Aircraft Classification Number - Flexible and Rigid Pavements

1. This section gives data about the Aircraft Classification Number (ACN) for an aircraft gross weight in relation to a subgrade strength value for flexible and rigid pavement.

The flexible and rigid pavement requirements graphs are given at standard tire pressure for the weight variants producing (at the MRW and max aft CG) the lowest MLG load and the highest MLG load for each type of aircraft.

To find the ACN of an aircraft on flexible and rigid pavement, you must know the aircraft gross weight and the subgrade strength.

NOTE : An aircraft with an ACN equal to or less than the reported PCN can operate on that pavement, subject to any limitation on the tire pressure.
(Ref: ICAO Aerodrome Design Manual, Part 3, Chapter 1, Second Edition 1983).

****ON A/C A330-200 A330-200F**

2. Aircraft Classification Number - ACN table

The tables in FIGURE 7-9-0-991-001-A and FIGURE 7-9-0-991-002-A gives ACN data in tabular format for all the operational weight variants of the aircraft.

As an approximation, use a linear interpolation in order to get the ACN at the required operating weight using the following equation:

$$- \text{ACN} = \text{ACN min} + (\text{ACN max} - \text{ACN min}) \times (\text{Operating weight} - 120\,000 \text{ kg}) / (\text{MRW} - 120\,000 \text{ kg})$$

Please note that the interpolation error can reach 5% to 10%.

As an approximation, use a linear interpolation in order to get the aircraft weight at the pavement PCN using the following equation:

$$- \text{Operating weight} = 120\,000 \text{ kg} + (\text{MRW} - 120\,000 \text{ kg}) \times (\text{PCN} - \text{ACN min}) / (\text{ACN max} - \text{ACN min})$$

Please note that the interpolation error can reach up to 5%.

With ACN max = ACN calculated at the MRW in the table and with ACN min = ACN calculated at 120 000 kg.

****ON A/C A330-300**

3. Aircraft Classification Number - ACN table

The table in FIGURE 7-9-0-991-003-A gives ACN data in tabular format for all the operational weight variants of the aircraft.

As an approximation, use a linear interpolation in order to get the ACN at the required operating weight using the following equation:

$$- \text{ACN} = \text{ACN min} + (\text{ACN max} - \text{ACN min}) \times (\text{Operating weight} - 125\,000 \text{ kg}) / (\text{MRW} - 125\,000 \text{ kg})$$

Please note that the interpolation error can reach 5% to 10%.

As an approximation, use a linear interpolation in order to get the aircraft weight at the pavement PCN using the following equation:

$$\text{Operating weight} = 125\,000 \text{ kg} + (\text{MRW} - 125\,000 \text{ kg}) \times (\text{PCN} - \text{ACN min}) / (\text{ACN max} - \text{ACN min})$$

Please note that the interpolation error can reach up to 5%.

With ACN max = ACN calculated at the MRW in the table and with ACN min = ACN calculated at 125 000 kg.

****ON A/C A330-800**

4. Aircraft Classification Number - ACN table

The table in FIGURE 7-9-0-991-022-A gives ACN data in tabular format for all the operational weight variants of the aircraft.

As an approximation, use a linear interpolation in order to get the ACN at the required operating weight using the following equation:

$$\text{ACN} = \text{ACN min} + (\text{ACN max} - \text{ACN min}) \times (\text{Operating weight} - 135\,000 \text{ kg}) / (\text{MRW} - 135\,000 \text{ kg})$$

Please note that the interpolation error can reach 5% to 10%.

As an approximation, use a linear interpolation in order to get the aircraft weight at the pavement PCN using the following equation:

$$\text{Operating weight} = 135\,000 \text{ kg} + (\text{MRW} - 135\,000 \text{ kg}) \times (\text{PCN} - \text{ACN min}) / (\text{ACN max} - \text{ACN min})$$

Please note that the interpolation error can reach up to 5%.

With ACN max = ACN calculated at the MRW in the table and with ACN min = ACN calculated at 135 000 kg.

****ON A/C A330-900**

5. Aircraft Classification Number - ACN table

The table in FIGURE 7-9-0-991-025-A gives ACN data in tabular format for all the operational weight variants of the aircraft.

As an approximation, use a linear interpolation in order to get the ACN at the required operating weight using the following equation:

$$\text{ACN} = \text{ACN min} + (\text{ACN max} - \text{ACN min}) \times (\text{Operating weight} - 140\,000 \text{ kg}) / (\text{MRW} - 140\,000 \text{ kg})$$

Please note that the interpolation error can reach 5% to 10%.

As an approximation, use a linear interpolation in order to get the aircraft weight at the pavement PCN using the following equation:

$$\text{Operating weight} = 140\,000 \text{ kg} + (\text{MRW} - 140\,000 \text{ kg}) \times (\text{PCN} - \text{ACN min}) / (\text{ACN max} - \text{ACN min})$$

Please note that the interpolation error can reach up to 5%.



AIRCRAFT CHARACTERISTICS - AIRPORT AND MAINTENANCE PLANNING

With ACN max = ACN calculated at the MRW in the table and with ACN min = ACN calculated at 140 000 kg.

For questions or specific calculation regarding ACN/PCN Reporting System, contact Airbus.



AIRCRAFT CHARACTERISTICS - AIRPORT AND MAINTENANCE PLANNING

**ON A/C A330-200

AIRCRAFT TYPE	ALL UP MASS (kg)	LOAD ON ONE MAIN GEAR LEG (%)	TIRE PRESSURE (MPa)	ACN FOR RIGID PAVEMENT SUBGRADES - MN/m ²				ACN FOR FLEXIBLE PAVEMENT SUBGRADES - CBR			
				High 150	Medium 80	Low 40	Ultra-low 20	High 15	Medium 10	Low 6	Ultra-low 3
A330-200 WV020	230 900	47.3	1.42	53	61	72	84	57	62	71	96
	120 000	47.2		28	27	30	35	26	27	30	36
A330-200 WV021	230 900	47.3	1.42	53	61	72	84	57	62	71	96
	120 000	47.2		28	27	30	35	26	27	30	36
A330-200 WV022	233 900	47.3	1.42	54	62	74	86	58	63	73	98
	120 000	47.2		28	27	30	35	26	27	30	36
A330-200 WV023	233 900	47.3	1.42	54	62	74	86	58	63	73	98
	120 000	47.2		28	27	30	35	26	27	30	36
A330-200 WV024	202 900	47.5	1.42	45	52	61	71	49	52	60	80
	120 000	47.3		28	27	31	35	26	27	30	37
A330-200 WV025	220 900	47.4	1.42	49	58	68	80	54	58	67	91
	120 000	47.2		28	27	30	35	26	27	30	36
A330-200 WV026	192 900	47.5	1.42	43	49	57	67	46	49	56	75
	120 000	47.4		28	27	31	35	26	27	30	37
A330-200 WV027	220 900	47.4	1.42	49	58	68	80	54	58	67	91
	120 000	47.2		28	27	30	35	26	27	30	36
A330-200 WV050	230 900	47.3	1.42	53	61	72	84	57	62	71	96
	120 000	47.2		28	27	30	35	26	27	30	36
A330-200 WV051	192 900	47.5	1.42	43	49	57	67	46	49	56	75
	120 000	47.4		28	27	31	35	26	27	30	37
A330-200 WV052	233 900	47.3	1.42	54	62	74	86	58	63	73	98
	120 000	47.2		28	27	30	35	26	27	30	36
A330-200 WV053	210 900	47.4	1.42	47	54	64	75	51	55	63	85
	120 000	47.3		28	27	31	35	26	27	30	37
A330-200 WV054	230 900	47.3	1.42	53	61	72	84	57	62	71	96
	120 000	47.2		28	27	30	35	26	27	30	36
A330-200 WV055	192 900	47.5	1.42	43	49	57	67	46	49	56	75
	120 000	47.4		28	27	31	35	26	27	30	37
A330-200 WV056	233 900	47.3	1.42	54	62	74	86	58	63	73	98
	120 000	47.2		28	27	30	35	26	27	30	36
A330-200 WV057	236 900	46.7	1.42	53	62	74	86	58	63	73	98
	120 000	46.6		27	27	30	34	26	27	29	36
A330-200 WV058	238 900	46.3	1.42	53	62	74	86	58	63	73	98
	120 000	46.2		27	26	30	34	25	26	29	35
A330-200 WV059	202 900	47.5	1.42	45	52	61	71	49	52	60	80
	120 000	47.3		28	27	31	35	26	27	30	37
A330-200 WV060	220 900	47.4	1.42	49	58	68	80	54	58	67	91
	120 000	47.2		28	27	30	35	26	27	30	36
A330-200 WV061	230 900	47.3	1.42	53	61	72	84	57	62	71	96
	120 000	47.2		28	27	30	35	26	27	30	36
A330-200 WV062	238 900	46.3	1.42	53	62	74	86	58	63	73	98
	120 000	46.2		27	26	30	34	25	26	29	35
A330-200 WV063	192 900	47.5	1.42	43	49	57	67	46	49	56	75
	120 000	47.4		28	27	31	35	26	27	30	37
A330-200 WV064	217 900	47.4	1.42	48	57	67	78	53	57	66	89
	120 000	47.3		28	27	30	35	26	27	30	36

F_AC_070900_1_0010101_01_04

Aircraft Classification Number
ACN Table (Sheet 1 of 2)
FIGURE-7-9-0-991-001-A01

**ON A/C A330-200

AIRCRAFT TYPE	ALL UP MASS (kg)	LOAD ON ONE MAIN GEAR LEG (%)	TIRE PRESSURE (MPa)	ACN FOR RIGID PAVEMENT SUBGRADES – MN/m ²				ACN FOR FLEXIBLE PAVEMENT SUBGRADES – CBR			
				High 150	Medium 80	Low 40	Ultra-low 20	High 15	Medium 10	Low 6	Ultra-low 3
A330-200 WV080	238 900	46.8	1.47	55	64	75	88	59	63	74	100
	120 000	46.6		28	27	30	35	26	27	29	36
A330-200 WV081	242 900	46.3	1.47	56	64	76	89	59	64	74	101
	120 000	46.2		27	27	30	34	25	27	29	35
A330-200 WV082	242 900	46.3	1.47	56	64	76	89	59	64	74	101
	120 000	46.2		27	27	30	34	25	27	29	35
A330-200 WV083	240 900	46.5	1.47	55	64	76	88	59	64	74	100
	120 000	46.4		27	27	30	35	26	27	29	36

F_AC_070900_1_0010102_01_02

Aircraft Classification Number
 ACN Table (Sheet 2 of 2)
 FIGURE-7-9-0-991-001-A01



AIRCRAFT CHARACTERISTICS - AIRPORT AND MAINTENANCE PLANNING

**ON A/C A330-200F

AIRCRAFT TYPE	ALL UP MASS (kg)	LOAD ON ONE MAIN GEAR LEG (%)	TIRE PRESSURE (Mpa)	ACN FOR RIGID PAVEMENT SUBGRADES - MN/m ²				ACN FOR FLEXIBLE PAVEMENT SUBGRADES - CBR			
				High 150	Medium 80	Low 40	Ultra-low 20	High 15	Medium 10	Low 6	Ultra-low 3
A330-200F WV000	233 900	47.3	1.42	54	62	74	86	58	63	73	98
	120 000	47.2		28	27	30	35	26	27	30	36
A330-200F WV001	227 900	47.3	1.42	52	60	71	83	56	61	70	95
	120 000	47.2		28	27	30	35	26	27	30	36
A330-200F WV002	233 900	47.3	1.42	54	62	74	86	58	63	73	98
	120 000	47.2		28	27	30	35	26	27	30	36

F_AC_070900_1_0020101_01_00

Aircraft Classification Number
ACN Table
FIGURE-7-9-0-991-002-A01

****ON A/C A330-300**

AIRCRAFT TYPE	ALL UP MASS (kg)	LOAD ON ONE MAIN GEAR LEG (%)	TIRE PRESSURE (MPa)	ACN FOR RIGID PAVEMENT SUBGRADES - MN/m?				ACN FOR FLEXIBLE PAVEMENT SUBGRADES - CBR			
				High 150	Medium 80	Low 40	Ultra-low 20	High 15	Medium 10	Low 6	Ultra-low 3
A330-300 WV000	212 900	47.4	1.31	46	53	63	75	51	55	64	86
	125 000	47.3		28	27	31	36	27	28	31	39
A330-300 WV001	184 900	47.9	1.31	40	45	53	62	44	47	53	71
	125 000	47.9		28	28	32	37	28	28	32	39
A330-300 WV002	212 900	47.4	1.31	46	53	63	75	51	55	64	86
	125 000	47.3		28	27	31	36	27	28	31	39
A330-300 WV003	215 900	47.2	1.33	47	54	64	76	52	56	64	87
	125 000	47.1		28	27	31	36	27	28	31	38
A330-300 WV004 (209)	209 900	47.8	1.33	46	53	63	74	51	55	63	85
	125 000	47.8		28	28	32	37	27	28	31	39
A330-300 WV004 (215)	215 900	47.8	1.33	47	55	66	77	53	57	66	89
	125 000	47.7		28	28	32	37	27	28	31	39
A330-300 WV010 (CG 33.5%)	217 900	47.0	1.33	47	55	65	76	52	56	65	88
	125 000	46.9		28	27	31	36	27	28	31	38
A330-300 WV010 (CG 39.13%)	217 900	47.8	1.33	48	56	67	78	53	58	67	90
	125 000	47.7		28	28	32	37	27	28	31	39
A330-300 WV011	212 900	47.8	1.33	47	54	64	76	52	56	64	87
	125 000	47.7		28	28	32	37	27	28	31	39
A330-300 WV012	218 900	47.8	1.33	48	56	67	79	54	58	67	91
	125 000	47.7		28	28	32	37	27	28	31	39
A330-300 WV013	215 900	47.8	1.33	47	55	66	77	53	57	66	89
	125 000	47.7		28	28	32	37	27	28	31	39
A330-300 WV014	205 900	47.9	1.33	45	52	62	72	50	54	62	83
	125 000	47.8		28	28	32	37	27	29	32	39
A330-300 WV020	230 900	47.8	1.42	53	62	73	86	57	62	72	98
	125 000	47.7		29	29	32	37	28	29	31	39
A330-300 WV022	233 900	47.7	1.45	55	63	75	87	59	63	74	100
	125 000	47.6		29	29	33	38	28	29	31	39
A330-300 WV024	205 900	47.9	1.42	46	53	63	73	50	54	62	83
	125 000	47.8		29	29	33	38	28	29	32	39

F_AC_070900_1_0030101_01_04

Aircraft Classification Number
 ACN Table (Sheet 1 of 4)
 FIGURE-7-9-0-991-003-A01

****ON A/C A330-300**

AIRCRAFT TYPE	ALL UP MASS (kg)	LOAD ON ONE MAIN GEAR LEG (%)	TIRE PRESSURE (MPa)	ACN FOR RIGID PAVEMENT SUBGRADES - MN/m?				ACN FOR FLEXIBLE PAVEMENT SUBGRADES - CBR			
				High 150	Medium 80	Low 40	Ultra-low 20	High 15	Medium 10	Low 6	Ultra-low 3
A330-300 WV025	217 900	47.8	1.42	49	57	68	79	54	58	67	90
	125 000	47.7		29	29	32	37	28	29	32	39
A330-300 WV026	217 900	47.8	1.42	49	57	68	79	54	58	67	90
	125 000	47.7		29	29	32	37	28	29	32	39
A330-300 WV027	198 900	47.9	1.42	45	51	60	70	48	52	59	79
	125 000	47.8		29	29	33	38	28	29	32	39
A330-300 WV030 (CG 39.83%)	199 900	47.9	1.45	45	52	61	71	49	52	59	80
	125 000	47.8		29	29	33	38	28	29	32	39
A330-300 WV030 (CG 39.81%)	199 900	47.9	1.45	45	52	61	71	49	52	59	80
	125 000	47.8		29	29	33	38	28	29	32	39
A330-300 WV030 (CG 39.82%)	199 900	47.9	1.45	45	52	61	71	49	52	59	80
	125 000	47.8		29	29	33	38	28	29	32	39
A330-300 WV031 (CG 39.83%)	199 900	47.9	1.45	45	52	61	71	49	52	59	80
	125 000	47.8		29	29	33	38	28	29	32	39
A330-300 WV031 (CG 39.81%)	199 900	47.9	1.45	45	52	61	71	49	52	59	80
	125 000	47.8		29	29	33	38	28	29	32	39
A330-300 WV031 (CG 39.82%)	199 900	47.9	1.45	45	52	61	71	49	52	59	80
	125 000	47.8		29	29	33	38	28	29	32	39
A330-300 WV032 (CG 40.17%)	190 900	47.9	1.45	43	49	57	67	46	49	56	74
	125 000	47.9		29	29	33	38	28	29	32	39
A330-300 WV032 (CG 39.41%)	190 900	47.8	1.45	43	49	57	67	46	49	56	74
	125 000	47.8		29	29	33	38	28	29	32	39
A330-300 WV032 (CG 39.39%)	190 900	47.8	1.45	43	49	57	66	46	49	55	74
	125 000	47.8		29	29	33	38	28	29	32	39
A330-300 WV033 (CG 40.17%)	190 900	47.9	1.45	43	49	57	67	46	49	56	74
	125 000	47.9		29	29	33	38	28	29	32	39
A330-300 WV033 (CG 39.41%)	190 900	47.8	1.45	43	49	57	67	46	49	56	74
	125 000	47.8		29	29	33	38	28	29	32	39
A330-300 WV033 (CG 39.39%)	190 900	47.8	1.45	43	49	57	66	46	49	55	74
	125 000	47.8		29	29	33	38	28	29	32	39

F_AC_070900_1_0030102_01_03

Aircraft Classification Number
ACN Table (Sheet 2 of 4)
FIGURE-7-9-0-991-003-A01

**ON A/C A330-300

AIRCRAFT TYPE	ALL UP MASS (kg)	LOAD ON ONE MAIN GEAR LEG (%)	TIRE PRESSURE (MPa)	ACN FOR RIGID PAVEMENT SUBGRADES - MN/m?				ACN FOR FLEXIBLE PAVEMENT SUBGRADES - CBR			
				High 150	Medium 80	Low 40	Ultra-low 20	High 15	Medium 10	Low 6	Ultra-low 3
A330-300 WV034 (CG 39.58%)	205 900	47.9	1.45	47	54	63	74	50	54	62	83
	125 000	47.8		29	29	33	38	28	29	32	39
A330-300 WV034 (CG 39.57%)	205 900	47.9	1.45	47	54	63	74	50	54	62	83
	125 000	47.8		29	29	33	38	28	29	32	39
A330-300 WV035 (CG 39.58%)	205 900	47.9	1.45	47	54	63	74	50	54	62	83
	125 000	47.8		29	29	33	38	28	29	32	39
A330-300 WV035 (CG 39.57%)	205 900	47.9	1.45	47	54	63	74	50	54	62	83
	125 000	47.8		29	29	33	38	28	29	32	39
A330-300 WV039 (CG 39.13%)	217 900	47.8	1.45	49	58	68	80	54	58	67	90
	125 000	47.7		29	29	33	38	28	29	32	39
A330-300 WV039 (CG 39.12%)	217 900	47.8	1.45	49	58	68	80	54	58	67	90
	125 000	47.7		29	29	33	38	28	29	32	39
A330-300 WV050	230 900	47.8	1.45	54	62	74	86	58	62	72	98
	125 000	47.7		29	29	33	38	28	29	31	39
A330-300 WV051	212 900	47.8	1.45	48	56	66	77	52	56	65	87
	125 000	47.7		29	29	33	38	28	29	32	39
A330-300 WV052	233 900	47.7	1.45	55	63	75	87	59	63	74	100
	125 000	47.6		29	29	33	38	28	29	31	39
A330-300 WV053	205 900	47.9	1.45	47	54	63	74	50	54	62	83
	125 000	47.8		29	29	33	38	28	29	32	39
A330-300 WV054	235 900	47.3	1.45	55	63	75	87	59	63	74	100
	125 000	47.2		29	28	32	37	27	29	31	39
A330-300 WV055	235 900	47.3	1.45	55	63	75	87	59	63	74	100
	125 000	47.2		29	28	32	37	27	29	31	39
A330-300 WV056	205 900	47.9	1.45	47	54	63	74	50	54	62	83
	125 000	47.8		29	29	33	38	28	29	32	39
A330-300 WV057 (CG 38.93%)	184 900	47.8	1.45	42	47	54	64	44	47	53	71
	125 000	47.7		29	29	33	38	28	29	32	39
A330-300 WV057 (CG 38.96%)	184 900	47.8	1.45	42	47	54	64	44	47	53	71
	125 000	47.7		29	29	33	38	28	29	32	39

F_AC_070900_1_0030103_01_02

Aircraft Classification Number
ACN Table (Sheet 3 of 4)
FIGURE-7-9-0-991-003-A01

**ON A/C A330-300

AIRCRAFT TYPE	ALL UP MASS (kg)	LOAD ON ONE MAIN GEAR LEG (%)	TIRE PRESSURE (MPa)	ACN FOR RIGID PAVEMENT SUBGRADES – MN/m ²				ACN FOR FLEXIBLE PAVEMENT SUBGRADES – CBR			
				High 150	Medium 80	Low 40	Ultra-low 20	High 15	Medium 10	Low 6	Ultra-low 3
A330-300 WV057 (CG 39.23%)	184 900	47.8	1.45	42	47	55	64	44	47	53	71
	125 000	47.7		29	29	33	38	28	29	32	39
A330-300 WV058	215 900	47.8	1.45	49	57	67	79	53	57	66	89
	125 000	47.7		29	29	33	38	28	29	32	39
A330-300 WV059	217 900	47.8	1.45	49	58	68	80	54	58	67	90
	125 000	47.7		29	29	33	38	28	29	32	39
A330-300 WV060	198 900	47.9	1.45	45	51	60	70	48	52	59	79
	125 000	47.8		29	29	33	38	28	29	32	39
A330-300 WV080	238 900	47.3	1.49	56	65	77	89	60	64	75	101
	125 000	47.2		29	29	32	37	27	29	31	39
A330-300 WV081	242 900	46.9	1.49	57	66	78	90	60	65	76	103
	125 000	46.8		29	28	32	37	27	28	31	38
A330-300 WV082	242 900	46.9	1.49	57	66	78	90	60	65	76	103
	125 000	46.8		29	28	32	37	27	28	31	38
A330-300 WV083	240 900	47.1	1.49	56	65	77	90	60	65	75	102
	125 000	47.0		29	29	32	37	27	28	31	38

F_AC_070900_1_0030104_01_02

Aircraft Classification Number
 ACN Table (Sheet 4 of 4)
 FIGURE-7-9-0-991-003-A01



AIRCRAFT CHARACTERISTICS - AIRPORT AND MAINTENANCE PLANNING

**ON A/C A330-800

AIRCRAFT TYPE	ALL UP MASS (kg)	LOAD ON ONE MAIN GEAR LEG (%)	TIRE PRESSURE (MPa)	ACN FOR RIGID PAVEMENT SUBGRADES - MN/m ²				ACN FOR FLEXIBLE PAVEMENT SUBGRADES - CBR			
				High 150	Medium 80	Low 40	Ultra-low 20	High 15	Medium 10	Low 6	Ultra-low 3
A330-800 WV800	242 900	46.3	1.47	56	64	76	89	59	64	74	101
	135 000	46.2		30	31	35	40	29	31	33	42
A330-800 WV801	242 900	46.3	1.47	56	64	76	89	59	64	74	101
	135 000	46.2		30	31	35	40	29	31	33	42
A330-800 WV802	238 900	46.8	1.47	55	64	75	88	59	63	74	100
	135 000	46.6		31	31	35	41	30	31	34	42
A330-800 WV803	234 900	47.2	1.47	55	63	74	87	58	63	73	99
	135 000	47.1		31	31	36	41	30	31	34	43
A330-800 WV804	230 900	47.3	1.47	54	62	73	85	57	62	71	97
	135 000	47.2		31	31	36	41	30	31	34	43
A330-800 WV805	220 900	47.4	1.47	51	58	69	80	54	58	67	91
	135 000	47.3		31	31	36	41	30	31	34	43
A330-800 WV806	215 900	47.4	1.47	49	57	67	78	53	57	65	88
	135 000	47.3		31	32	36	41	30	31	34	43
A330-800 WV807	210 900	47.4	1.47	48	55	65	75	51	55	63	85
	135 000	47.3		31	32	36	41	30	31	34	43
A330-800 WV808	205 900	47.4	1.47	47	53	63	73	50	53	61	82
	135 000	47.4		31	32	36	41	30	31	35	43
A330-800 WV809	200 900	47.5	1.47	45	52	61	71	48	52	59	79
	135 000	47.4		31	32	36	41	30	31	35	43
A330-800 WV820	251 900	46.9	1.56	61	70	83	96	64	69	80	108
	135 000	46.8		31	32	36	41	30	31	34	43
A330-800 WV821	251 900	46.9	1.56	61	70	83	96	64	69	80	108
	135 000	46.8		31	32	36	41	30	31	34	43
A330-800 WV822	247 900	47.0	1.56	60	69	81	94	63	67	78	106
	135 000	46.9		31	32	36	41	30	31	34	43

F_AC_070900_1_0220101_01_02

Aircraft Classification Number
ACN Table
FIGURE-7-9-0-991-022-A01

**ON A/C A330-900

AIRCRAFT TYPE	ALL UP MASS (kg)	LOAD ON ONE MAIN GEAR LEG (%)	TIRE PRESSURE (MPa)	ACN FOR RIGID PAVEMENT SUBGRADES – MN/m ²				ACN FOR FLEXIBLE PAVEMENT SUBGRADES – CBR			
				High 150	Medium 80	Low 40	Ultra-low 20	High 15	Medium 10	Low 6	Ultra-low 3
A330-900 WV900	242 900	46.9	1.49	57	66	78	90	60	65	76	103
	140 000	46.8		32	33	37	43	31	32	36	45
A330-900 WV901	242 900	46.9	1.49	57	66	78	90	60	65	76	103
	140 000	46.8		32	33	37	43	31	32	36	45
A330-900 WV902	238 900	47.3	1.49	56	65	77	89	60	64	75	101
	140 000	47.2		32	33	38	43	31	33	36	46
A330-900 WV903	234 900	47.6	1.49	55	64	76	88	59	64	74	100
	140 000	47.6		32	33	38	44	32	33	36	46
A330-900 WV904	230 900	47.8	1.49	54	63	74	86	58	62	72	98
	140 000	47.7		32	33	38	44	32	33	36	46
A330-900 WV905	220 900	47.8	1.49	52	59	70	81	55	59	68	92
	140 000	47.7		32	33	38	44	32	33	37	46
A330-900 WV906	215 900	47.8	1.49	49	58	68	79	54	57	66	89
	140 000	47.7		32	33	38	44	32	33	37	46
A330-900 WV907	210 900	47.8	1.49	48	56	66	77	52	56	64	86
	140 000	47.8		32	34	38	44	32	33	37	47
A330-900 WV908	205 900	47.9	1.49	47	54	64	74	51	54	62	83
	140 000	47.8		32	34	38	44	32	33	37	47
A330-900 WV920	251 900	46.9	1.56	61	70	83	96	64	69	80	108
	140 000	46.8		32	33	38	43	31	33	36	45
A330-900 WV921	251 900	46.9	1.56	61	70	83	96	64	69	80	108
	140 000	46.8		32	33	38	43	31	33	36	45
A330-900 WV922	247 900	47.1	1.56	60	69	81	94	63	68	79	106
	140 000	47.0		32	33	38	44	31	33	36	45

F_AC_070900_1_0250101_01_02

Aircraft Classification Number
ACN Table
FIGURE-7-9-0-991-025-A01

7-10-0 ACR/PCR Reporting System - Flexible And Rigid Pavement****ON A/C A330-200 A330-200F A330-300 A330-800 A330-900**ACR/PCR Reporting System - Flexible and Rigid Pavements

1. The ACR/PCR system has been developed by the ICAO to overcome the deficiencies of the ACN/PCN system. Significant advances in pavement design methods had occurred since its development in the late 1970s early 1980s, leading to inconsistencies with the pavement-strength-rating system.

The ACR/PCR system entails new procedures for the determination of both the ACR and the PCR that are consistent with the current pavement design procedures. This allows to capture the effects of the improved characteristics of new pavement materials as well as modern landing gear configurations, thus leading to an improved accuracy.

This section give data about the Aircraft Classification Rating (ACR) for the maximum ramp weight in relation with standard subgrade strength values for flexible and rigid pavement.

To determine the ACR at other aircraft gross weight, use the official ICAO-ACR software.

NOTE : An aircraft with an ACR equal to or less than the reported PCR can operate on that pavement, subject to any limitation on the tire pressure. (Ref: ICAO Aerodrome Design Manual, Part 3, Third Edition 2020).

2. Aircraft Classification Rating - ACR Table
The table FIGURE 7-10-0-991-001-A, FIGURE 7-10-0-991-002-A, FIGURE 7-10-0-991-003-A, FIGURE 7-10-0-991-004-A and FIGURE 7-10-0-991-005-A give ACR data in tabular format for all the operational weight variants of the aircraft.
For questions or specific calculation related to ACR/PCR reporting system, contact Airbus.

**ON A/C A330-200

AIRCRAFT TYPE	ALL UP MASS (kg)	LOAD ON ONE MAIN GEAR LEG (%)	TIRE PRESSURE (MPa)	ACR FOR RIGID PAVEMENT SUBGRADES - MPa				ACR FOR FLEXIBLE PAVEMENT SUBGRADES - MPa			
				HIGH 200	MEDIUM 120	LOW 80	ULTRA-LOW 50	HIGH 200	MEDIUM 120	LOW 80	ULTRA-LOW 50
A330-200 WV020	230 900	47.3	1.42	600	690	780	880	560	580	640	780
A330-200 WV021	230 900	47.3	1.42	600	690	780	880	560	580	640	780
A330-200 WV022	233 900	47.3	1.42	610	700	790	890	560	590	650	790
A330-200 WV023	233 900	47.3	1.42	610	700	790	890	560	590	650	790
A330-200 WV024	202 900	47.5	1.42	510	580	650	730	490	510	540	640
A330-200 WV025	220 900	47.4	1.42	570	650	730	820	530	550	600	730
A330-200 WV026	192 900	47.5	1.42	480	540	600	680	460	480	510	600
A330-200 WV027	220 900	47.4	1.42	570	650	730	820	530	550	600	730
A330-200 WV050	230 900	47.3	1.42	600	690	780	880	560	580	640	780
A330-200 WV051	192 900	47.5	1.42	480	540	600	680	460	480	510	600
A330-200 WV052	233 900	47.3	1.42	610	700	790	890	560	590	650	790
A330-200 WV053	210 900	47.4	1.42	540	610	680	770	510	530	570	680
A330-200 WV054	230 900	47.3	1.42	600	690	780	880	560	580	640	780
A330-200 WV055	192 900	47.5	1.42	480	540	600	680	460	480	510	600
A330-200 WV056	233 900	47.3	1.42	610	700	790	890	560	590	650	790
A330-200 WV057	236 900	46.7	1.42	610	700	790	890	560	590	650	790
A330-200 WV058	238 900	46.3	1.42	610	700	790	890	560	590	650	790
A330-200 WV059	202 900	47.5	1.42	510	580	650	730	490	510	540	640
A330-200 WV060	220 900	47.4	1.42	570	650	730	820	530	550	600	730
A330-200 WV061	230 900	47.3	1.42	600	690	780	880	560	580	640	780
A330-200 WV062	238 900	46.3	1.42	610	700	790	890	560	590	650	790
A330-200 WV063	192 900	47.5	1.42	480	540	600	680	460	480	510	600
A330-200 WV064	217 900	47.4	1.42	560	640	710	810	520	550	590	710

F_AC_071000_1_0010101_01_00

ACR Table
(Sheet 1 of 2)
FIGURE-7-10-0-991-001-A01

**ON A/C A330-200

AIRCRAFT TYPE	ALL UP MASS (kg)	LOAD ON ONE MAIN GEAR LEG (%)	TIRE PRESSURE (MPa)	ACR FOR RIGID PAVEMENT SUBGRADES – MPa				ACR FOR FLEXIBLE PAVEMENT SUBGRADES – MPa			
				HIGH 200	MEDIUM 120	LOW 80	ULTRA-LOW 50	HIGH 200	MEDIUM 120	LOW 80	ULTRA-LOW 50
A330-200 WV080	238 900	46.8	1.47	630	720	800	910	570	600	660	810
A330-200 WV081	242 900	46.3	1.47	630	730	810	920	580	600	660	820
A330-200 WV082	242 900	46.3	1.47	630	730	810	920	580	600	660	820
A330-200 WV083	240 900	46.5	1.47	630	720	810	910	580	600	660	810

F_AC_071000_1_0010102_01_00

ACR Table
 (Sheet 2 of 2)
 FIGURE-7-10-0-991-001-A01

**ON A/C A330-200F

AIRCRAFT TYPE	ALL UP MASS (kg)	LOAD ON ONE MAIN GEAR LEG (%)	TIRE PRESSURE (MPa)	ACR FOR RIGID PAVEMENT SUBGRADES - MPa				ACR FOR FLEXIBLE PAVEMENT SUBGRADES - MPa			
				HIGH 200	MEDIUM 120	LOW 80	ULTRA-LOW 50	HIGH 200	MEDIUM 120	LOW 80	ULTRA-LOW 50
A330-200F WV000	233 900	47.3	1.42	610	700	790	890	560	590	650	790
A330-200F WV001	227 900	47.3	1.42	590	680	760	860	550	570	630	760
A330-200F WV002	233 900	47.3	1.42	610	700	790	890	560	590	650	790

F_AC_071000_1_0020101_01_00

ACR Table
FIGURE-7-10-0-991-002-A01



AIRCRAFT CHARACTERISTICS - AIRPORT AND MAINTENANCE PLANNING

****ON A/C A330-300**

AIRCRAFT TYPE	ALL UP MASS (kg)	LOAD ON ONE MAIN GEAR LEG (%)	TIRE PRESSURE (MPa)	ACR FOR RIGID PAVEMENT SUBGRADES - MPa				ACR FOR FLEXIBLE PAVEMENT SUBGRADES - MPa			
				HIGH 200	MEDIUM 120	LOW 80	ULTRA-LOW 50	HIGH 200	MEDIUM 120	LOW 80	ULTRA-LOW 50
A330-300 WV000	212 900	47.4	1.31	530	600	680	770	500	530	570	690
A330-300 WV001	184 900	47.9	1.31	450	500	560	640	440	460	490	560
A330-300 WV002	212 900	47.4	1.31	530	600	680	770	500	530	570	690
A330-300 WV003	215 900	47.2	1.33	540	610	690	790	510	530	580	700
A330-300 WV004 (209)	209 900	47.8	1.33	530	600	680	770	500	520	570	680
A330-300 WV004 (215)	215 900	47.8	1.33	540	630	700	800	520	540	590	710
A330-300 WV010 (CG 33.5%)	217 900	47.0	1.33	540	620	700	790	510	540	580	700
A330-300 WV010 (CG 39.13%)	217 900	47.8	1.33	550	630	710	810	520	550	590	720
A330-300 WV011	212 900	47.8	1.33	540	610	690	790	510	530	580	700
A330-300 WV012	218 900	47.8	1.33	550	640	720	820	520	550	600	730
A330-300 WV013	215 900	47.8	1.33	540	630	700	800	520	540	590	710
A330-300 WV014	205 900	47.9	1.33	510	590	660	750	490	510	550	660
A330-300 WV020	230 900	47.8	1.42	610	700	790	890	560	590	640	790
A330-300 WV022	233 900	47.7	1.45	620	720	800	910	570	600	650	810
A330-300 WV024	205 900	47.9	1.42	530	600	670	760	500	520	560	660
A330-300 WV025	217 900	47.8	1.42	560	650	720	820	530	550	600	720
A330-300 WV026	217 900	47.8	1.42	560	650	720	820	530	550	600	720
A330-300 WV027	198 900	47.9	1.42	500	570	640	720	480	500	540	630
A330-300 WV030 (CG 39.83%)	199 900	47.9	1.45	510	580	640	730	490	500	540	640
A330-300 WV030 (CG 39.81%)	199 900	47.9	1.45	510	580	640	730	490	500	540	640
A330-300 WV030 (CG 39.82%)	199 900	47.9	1.45	510	580	640	730	490	500	540	640

F_AC_071000_1_0030101_01_00

ACR Table
(Sheet 1 of 3)
FIGURE-7-10-0-991-003-A01

****ON A/C A330-300**

AIRCRAFT TYPE	ALL UP MASS (kg)	LOAD ON ONE MAIN GEAR LEG (%)	TIRE PRESSURE (MPa)	ACR FOR RIGID PAVEMENT SUBGRADES – MPa				ACR FOR FLEXIBLE PAVEMENT SUBGRADES – MPa			
				HIGH 200	MEDIUM 120	LOW 80	ULTRA-LOW 50	HIGH 200	MEDIUM 120	LOW 80	ULTRA-LOW 50
A330-300 WV031 (CG 39.83%)	199 900	47.9	1.45	510	580	640	730	490	500	540	640
A330-300 WV031 (CG 39.81%)	199 900	47.9	1.45	510	580	640	730	490	500	540	640
A330-300 WV031 (CG 39.82%)	199 900	47.9	1.45	510	580	640	730	490	500	540	640
A330-300 WV032 (CG 40.17%)	190 900	47.9	1.45	480	540	600	680	470	480	510	600
A330-300 WV032 (CG 39.41%)	190 900	47.8	1.45	480	540	600	680	470	480	510	590
A330-300 WV032 (CG 39.39%)	190 900	47.8	1.45	480	540	600	680	470	480	510	590
A330-300 WV033 (CG 40.17%)	190 900	47.9	1.45	480	540	600	680	470	480	510	600
A330-300 WV033 (CG 39.41%)	190 900	47.8	1.45	480	540	600	680	470	480	510	590
A330-300 WV033 (CG 39.39%)	190 900	47.8	1.45	480	540	600	680	470	480	510	590
A330-300 WV034 (CG 39.58%)	205 900	47.9	1.45	530	600	670	760	500	520	560	670
A330-300 WV034 (CG 39.57%)	205 900	47.9	1.45	530	600	670	760	500	520	560	670
A330-300 WV035 (CG 39.58%)	205 900	47.9	1.45	530	600	670	760	500	520	560	670
A330-300 WV035 (CG 39.57%)	205 900	47.9	1.45	530	600	670	760	500	520	560	670
A330-300 WV039 (CG 39.13%)	217 900	47.8	1.45	570	650	730	820	530	550	600	720
A330-300 WV039 (CG 39.12%)	217 900	47.8	1.45	570	650	730	820	530	550	600	720
A330-300 WV050	230 900	47.8	1.45	610	700	790	890	560	590	640	790
A330-300 WV051	212 900	47.8	1.45	550	630	700	800	520	540	580	700

F_AC_071000_1_0030102_01_00

ACR Table
(Sheet 2 of 3)
FIGURE-7-10-0-991-003-A01

**ON A/C A330-300

AIRCRAFT TYPE	ALL UP MASS (kg)	LOAD ON ONE MAIN GEAR LEG (%)	TIRE PRESSURE (MPa)	ACR FOR RIGID PAVEMENT SUBGRADES - MPa				ACR FOR FLEXIBLE PAVEMENT SUBGRADES - MPa			
				HIGH 200	MEDIUM 120	LOW 80	ULTRA-LOW 50	HIGH 200	MEDIUM 120	LOW 80	ULTRA-LOW 50
A330-300 WV052	233 900	47.7	1.45	620	720	800	910	570	600	650	810
A330-300 WV053	205 900	47.9	1.45	530	600	670	760	500	520	560	670
A330-300 WV054	235 900	47.3	1.45	620	720	800	910	570	600	650	800
A330-300 WV055	235 900	47.3	1.45	620	720	800	910	570	600	650	800
A330-300 WV056	205 900	47.9	1.45	530	600	670	760	500	520	560	670
A330-300 WV057 (CG 38.93%)	184 900	47.8	1.45	460	520	570	650	450	460	490	570
A330-300 WV057 (CG 38.96%)	184 900	47.8	1.45	460	520	570	650	450	460	490	570
A330-300 WV057 (CG 39.23%)	184 900	47.8	1.45	460	520	580	650	450	460	490	570
A330-300 WV058	215 900	47.8	1.45	560	640	720	810	530	550	590	710
A330-300 WV059	217 900	47.8	1.45	570	650	730	820	530	550	600	720
A330-300 WV060	198 900	47.9	1.45	510	570	640	720	490	500	540	630
A330-300 WV080	238 900	47.3	1.49	640	730	820	920	580	610	670	820
A330-300 WV081	242 900	46.9	1.49	650	740	830	930	590	610	670	830
A330-300 WV082	242 900	46.9	1.49	650	740	830	930	590	610	670	830
A330-300 WV083	240 900	47.1	1.49	640	740	820	930	590	610	670	830

F_AC_071000_1_0030103_01_00

ACR Table
(Sheet 3 of 3)
FIGURE-7-10-0-991-003-A01

****ON A/C A330-800**

AIRCRAFT TYPE	ALL UP MASS (kg)	LOAD ON ONE MAIN GEAR LEG (%)	TIRE PRESSURE (MPa)	ACR FOR RIGID PAVEMENT SUBGRADES – MPa				ACR FOR FLEXIBLE PAVEMENT SUBGRADES – MPa			
				HIGH 200	MEDIUM 120	LOW 80	ULTRA-LOW 50	HIGH 200	MEDIUM 120	LOW 80	ULTRA-LOW 50
A330-800 WV800	242 900	46.3	1.47	630	730	810	920	580	600	660	820
A330-800 WV801	242 900	46.3	1.47	630	730	810	920	580	600	660	820
A330-800 WV802	238 900	46.8	1.47	630	720	800	910	570	600	660	810
A330-800 WV803	234 900	47.2	1.47	620	710	800	900	570	590	650	800
A330-800 WV804	230 900	47.3	1.47	610	700	780	880	560	590	640	780
A330-800 WV805	220 900	47.4	1.47	570	660	730	830	540	560	600	730
A330-800 WV806	215 900	47.4	1.47	560	640	710	800	530	540	590	710
A330-800 WV807	210 900	47.4	1.47	540	620	690	780	510	530	570	680
A330-800 WV808	205 900	47.4	1.47	530	600	660	750	500	520	550	660
A330-800 WV809	200 900	47.5	1.47	510	580	640	730	490	500	540	630
A330-800 WV820	251 900	46.9	1.56	690	790	880	990	620	650	710	880
A330-800 WV821	251 900	46.9	1.56	690	790	880	990	620	650	710	880
A330-800 WV822	247 900	47.0	1.56	680	770	860	970	610	640	700	860

F_AC_071000_1_0040101_01_00

ACR Table
FIGURE-7-10-0-991-004-A01

****ON A/C A330-900**

AIRCRAFT TYPE	ALL UP MASS (kg)	LOAD ON ONE MAIN GEAR LEG (%)	TIRE PRESSURE (MPa)	ACR FOR RIGID PAVEMENT SUBGRADES – MPa				ACR FOR FLEXIBLE PAVEMENT SUBGRADES – MPa			
				HIGH 200	MEDIUM 120	LOW 80	ULTRA-LOW 50	HIGH 200	MEDIUM 120	LOW 80	ULTRA-LOW 50
A330-900 WV900	242 900	46.9	1.49	650	740	830	930	590	610	670	830
A330-900 WV901	242 900	46.9	1.49	650	740	830	930	590	610	670	830
A330-900 WV902	238 900	47.3	1.49	640	730	820	920	580	610	670	820
A330-900 WV903	234 900	47.6	1.49	630	720	810	910	580	600	660	810
A330-900 WV904	230 900	47.8	1.49	620	710	790	890	570	590	650	790
A330-900 WV905	220 900	47.8	1.49	580	670	740	840	540	560	610	740
A330-900 WV906	215 900	47.8	1.49	570	650	720	810	530	550	590	720
A330-900 WV907	210 900	47.8	1.49	550	620	700	790	520	540	580	690
A330-900 WV908	205 900	47.9	1.49	540	600	670	760	510	520	560	670
A330-900 WV920	251 900	46.9	1.56	690	790	880	990	620	650	710	880
A330-900 WV921	251 900	46.9	1.56	690	790	880	990	620	650	710	880
A330-900 WV922	247 900	47.1	1.56	680	780	870	970	610	640	700	870

F_AC_071000_1_0050101_01_00

ACR Table
FIGURE-7-10-0-991-005-A01



SCALED DRAWINGS

8-0-0 SCALED DRAWINGS

**ON A/C A330-200 A330-200F A330-300 A330-800 A330-900

Scaled Drawings

1. This section provides the scaled drawings.

NOTE : When printing this drawing, make sure to adjust for proper scaling.

****ON A/C A330-200**

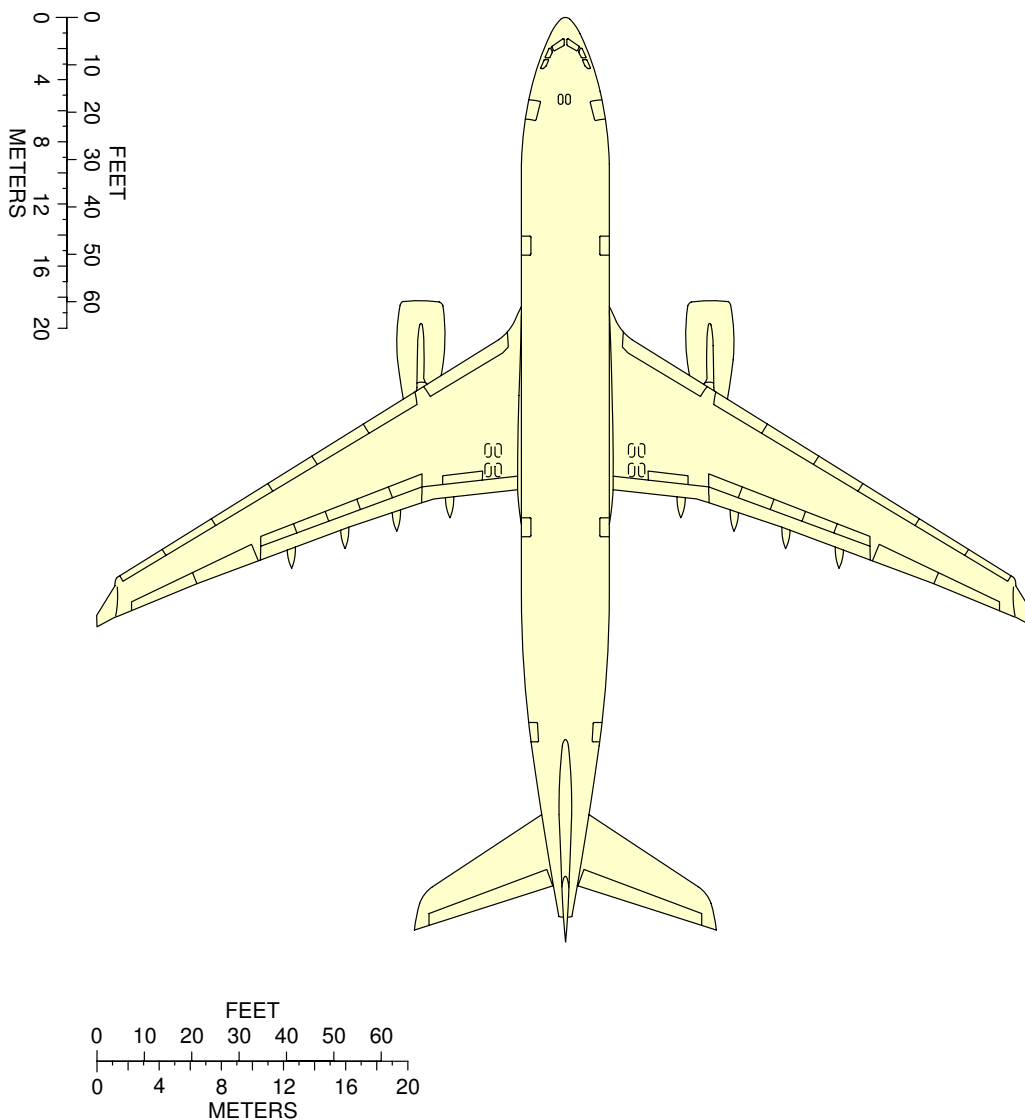

NOTE:
WHEN PRINTING THIS DRAWING, MAKE SURE TO ADJUST FOR PROPER SCALING.

F_AC_080000_1_0020101_01_01

Scaled Drawing
FIGURE-8-0-0-991-002-A01

****ON A/C A330-300**

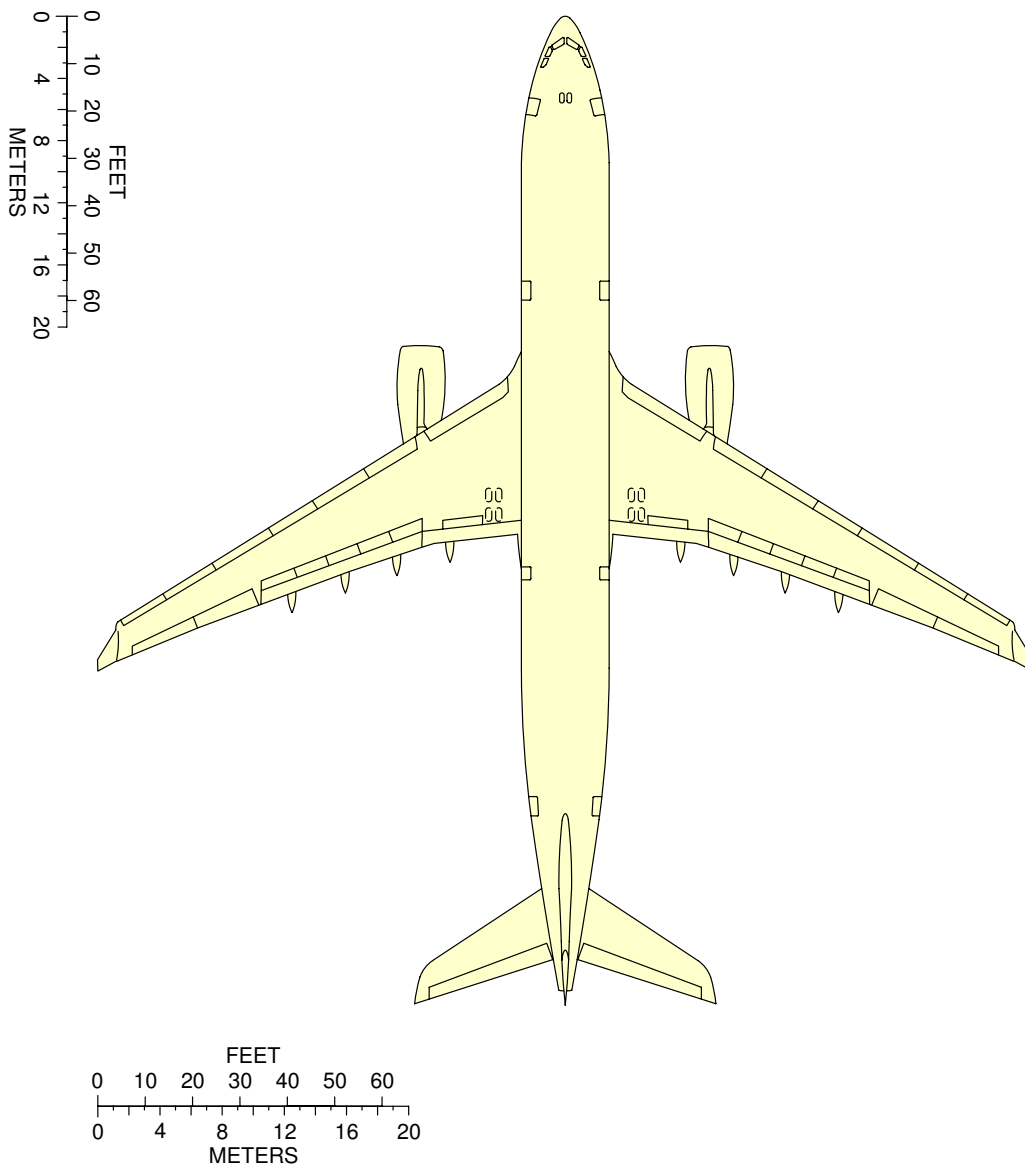

NOTE:
WHEN PRINTING THIS DRAWING, MAKE SURE TO ADJUST FOR PROPER SCALING.

F_AC_080000_1_0020201_01_01

Scaled Drawing
FIGURE-8-0-0-991-002-B01

****ON A/C A330-200F**

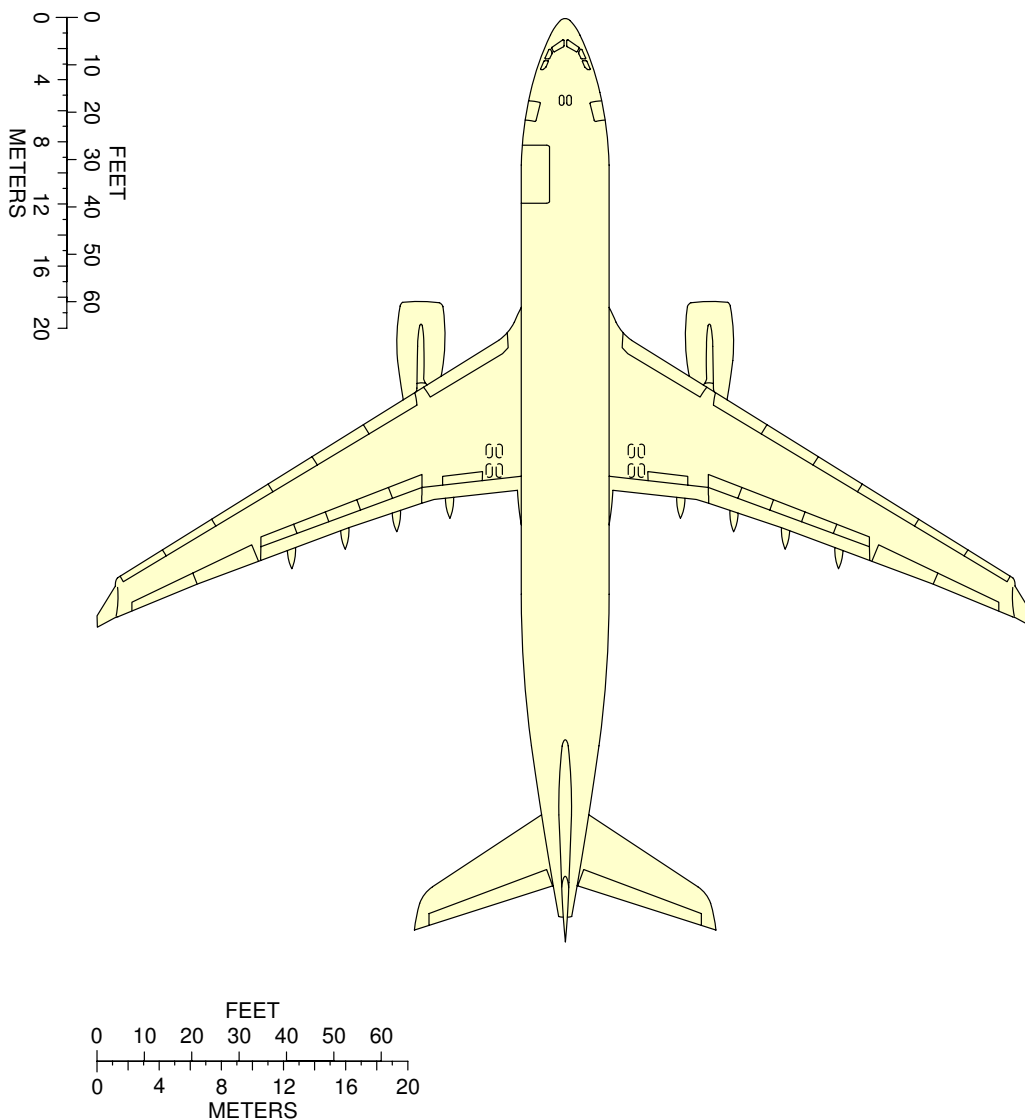

NOTE:
WHEN PRINTING THIS DRAWING, MAKE SURE TO ADJUST FOR PROPER SCALING.

F_AC_080000_1_0020301_01_01

Scaled Drawing
FIGURE-8-0-0-991-002-C01

****ON A/C A330-800**

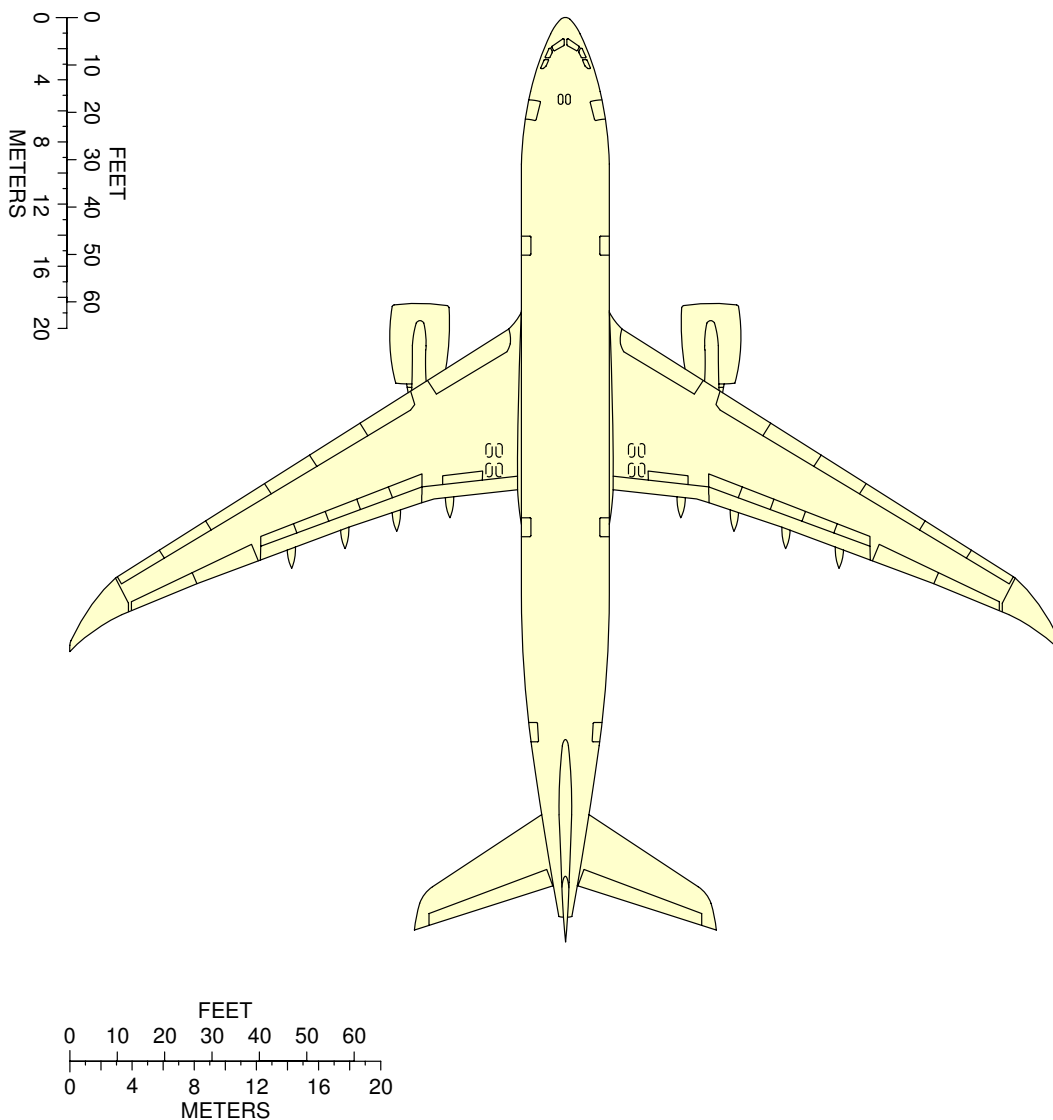

NOTE:
WHEN PRINTING THIS DRAWING, MAKE SURE TO ADJUST FOR PROPER SCALING.

F_AC_080000_1_0050101_01_00

Scaled Drawing
FIGURE-8-0-0-991-005-A01

****ON A/C A330-900**

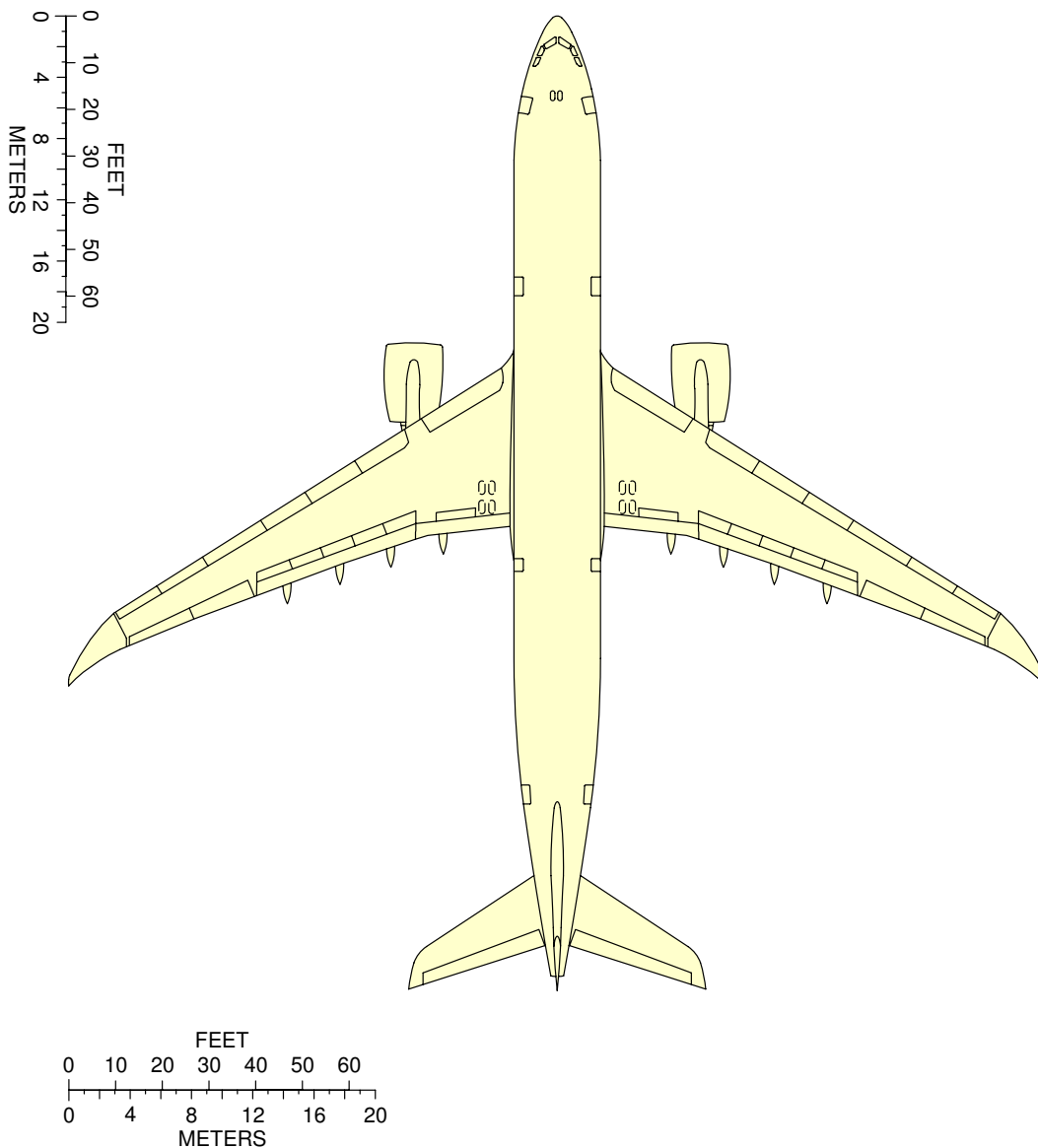

NOTE:
WHEN PRINTING THIS DRAWING, MAKE SURE TO ADJUST FOR PROPER SCALING.

F_AC_080000_1_0060101_01_00

Scaled Drawing
FIGURE-8-0-0-991-006-A01

AIRCRAFT RESCUE AND FIRE FIGHTING

10-0-0 AIRCRAFT RESCUE AND FIRE FIGHTING

****ON A/C A330-200 A330-300**Aircraft Rescue and Fire Fighting

1. Aircraft Rescue and Fire Fighting Charts

This sections provides data related to aircraft rescue and fire fighting.

The figures contained in this section are the figures that are in the Aircraft Rescue and Fire Fighting Charts poster available for download on AIRBUSWorld and the Airbus website.

**ON A/C A330-200 A330-300



AIRBUS

A330-200/-300

Aircraft Rescue and Fire Fighting Chart ARFC

NOTE:

THIS CHART GIVES THE GENERAL LAYOUT OF THE A330-200 AND A330-300 STANDARD VERSION.
THE NUMBER AND ARRANGEMENT OF THE INDIVIDUAL ITEMS VARY WITH THE CUSTOMERS.
FIGURES CONTAINED IN THIS POSTER ARE AVAILABLE SEPARATLY IN THE CHAPTER 10 OF THE
"AIRCRAFT CHARACTERISTICS - AIRPORT AND MAINTENANCE PLANNING" DOCUMENT.

ISSUED BY:
AIRBUS S.A.S
CUSTOMER SERVICES
TECHNICAL DATA SUPPORT AND SERVICES
31707 BLAGNAC CEDEX
FRANCE

REVISION DATE: JULY 2018
REFERENCE : F_RF_000000_1_A330000
SHEET 1/2

© AIRBUS S.A.S. 2013 . All rights reserved.

F_AC_100000_1_0010101_01_04

Front Page
FIGURE-10-0-0-991-001-A01

**ON A/C A330-200 A330-300

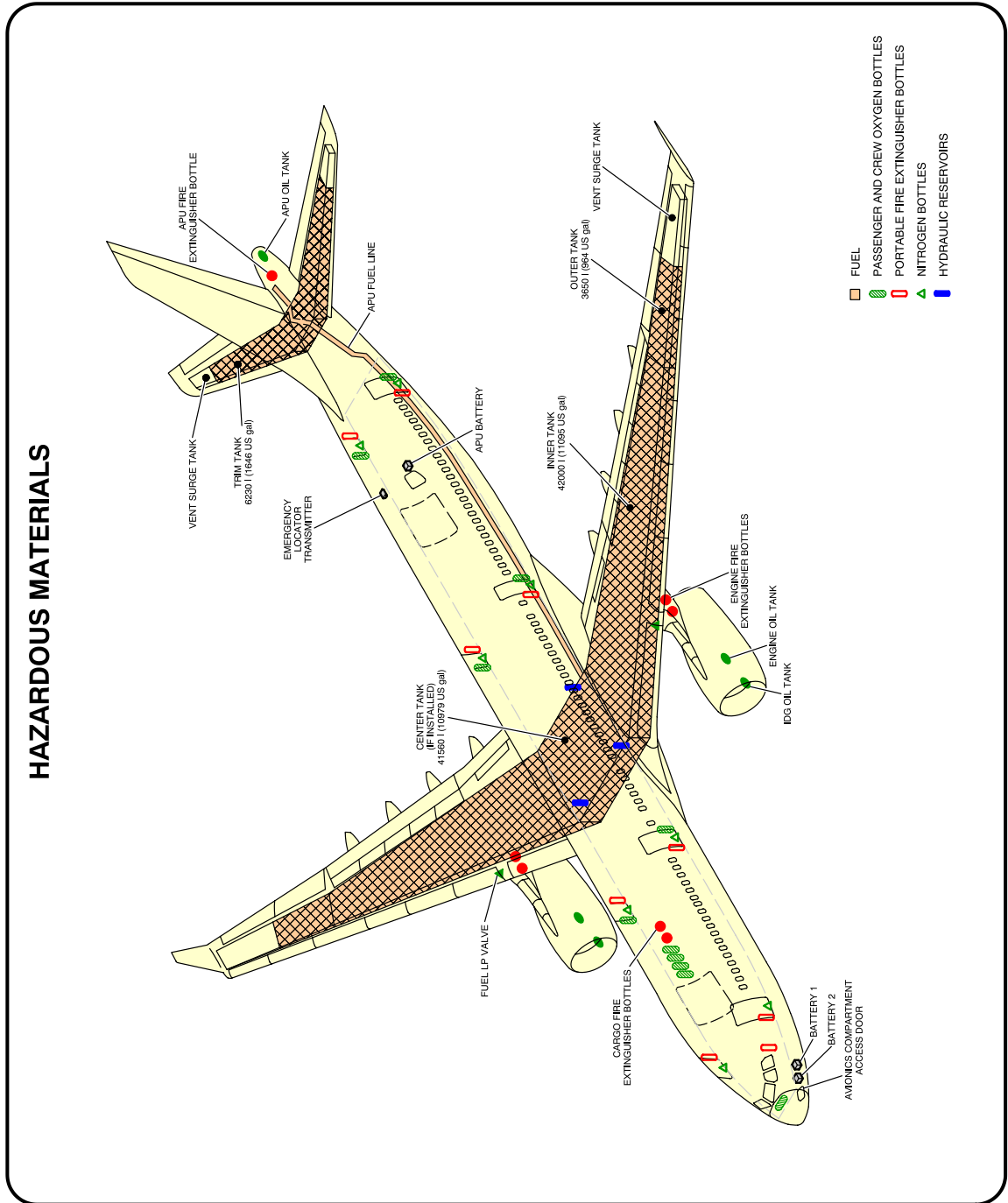

HAZARDOUS MATERIALS

F_AC_100000_1_0020101_01_01

Highly Flammable and Hazardous Materials and Components
FIGURE-10-0-0-991-002-A01

**ON A/C A330-200 A330-300

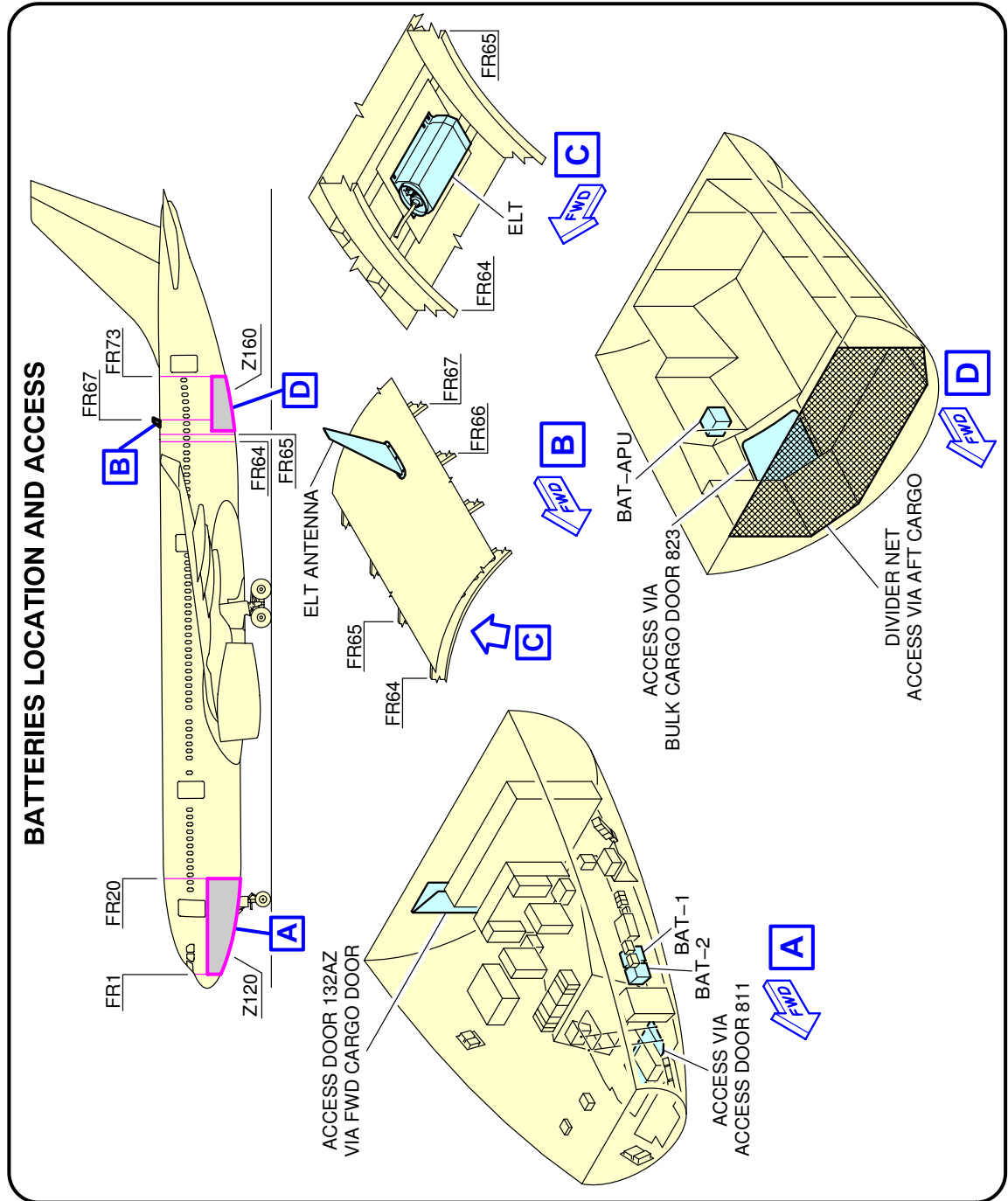

F_AC_100000_1_0670101_01_01

Batteries Location and Access
FIGURE-10-0-0-991-067-A01

**ON A/C A330-200 A330-300

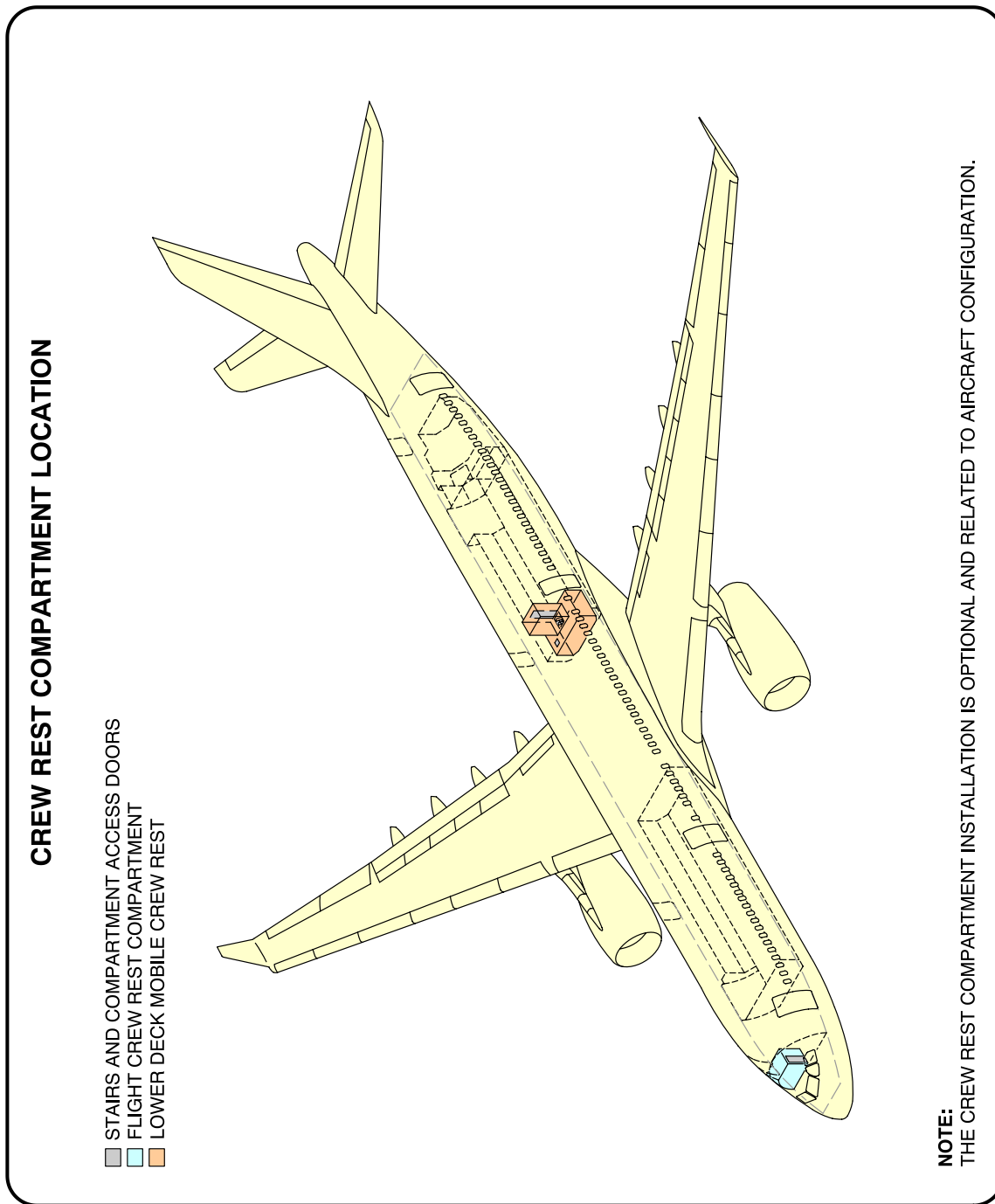

F_AC_100000_1_0030101_01_00

Crew Rest Compartments Location
FIGURE-10-0-0-991-003-A01

**ON A/C A330-200 A330-300

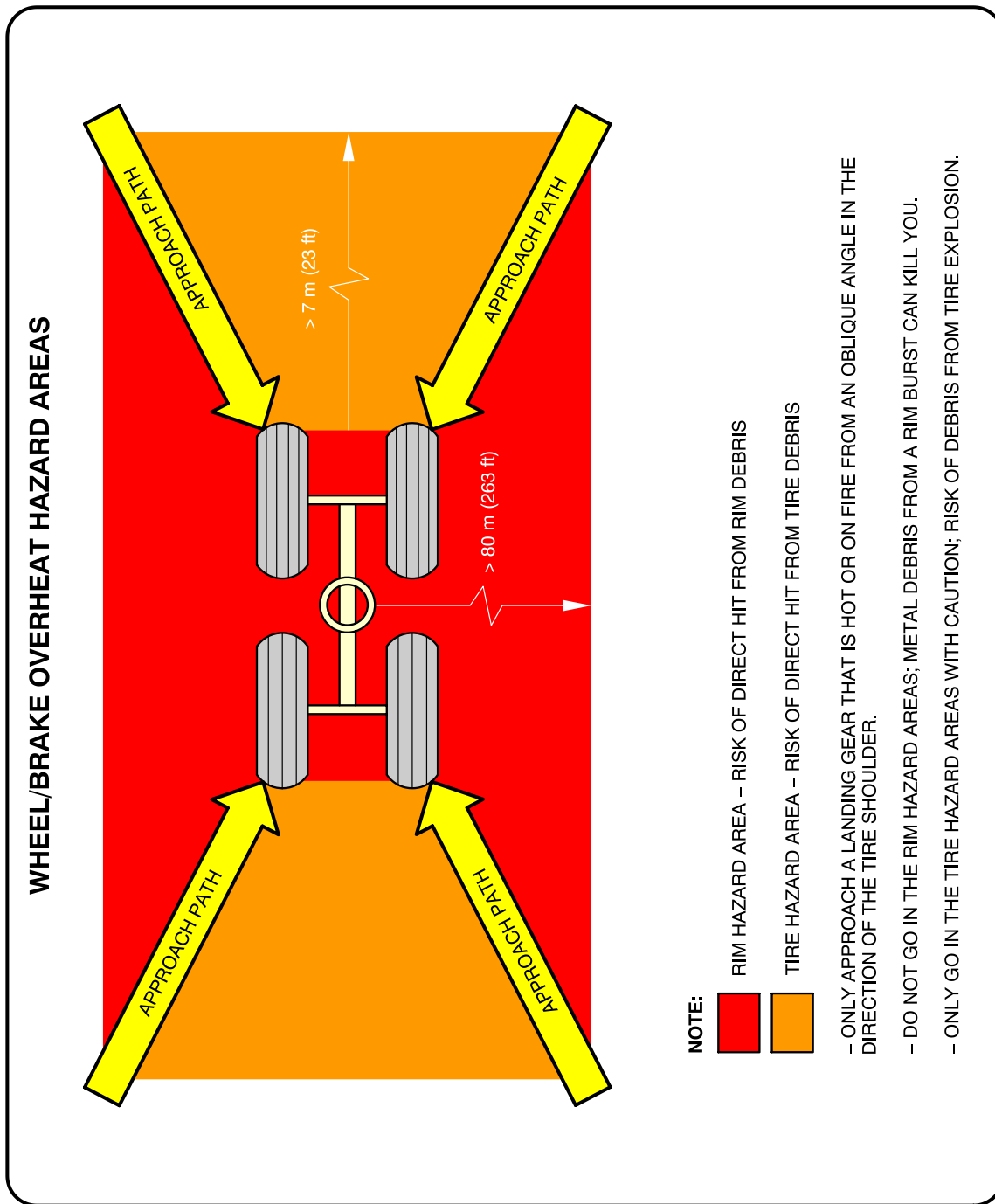

F_AC_100000_1_0040101_01_00

Wheel/Brake Overheat
Wheel Safety Area (Sheet 1 of 2)
FIGURE-10-0-0-991-004-A01

**ON A/C A330-200 A330-300

BRAKE OVERHEAT AND LANDING GEAR FIRE

WARNING: BE VERY CAREFUL WHEN THERE IS A BRAKE OVERHEAT AND/OR LANDING GEAR FIRE. THERE IS A RISK OF TIRE EXPLOSION AND/OR WHEEL RIM BURST THAT CAN CAUSE DEATH OR INJURY. MAKE SURE THAT YOU OBEY THE SAFETY PRECAUTIONS THAT FOLLOW.

THE PROCEDURES THAT FOLLOW GIVE RECOMMENDATIONS AND SAFETY PRECAUTIONS FOR THE COOLING OF VERY HOT BRAKES AFTER ABNORMAL OPERATIONS SUCH AS A REJECTED TAKE-OFF OR OVERWEIGHT LANDING. FOR THE COOLING OF BRAKES AFTER NORMAL TAXI-IN, REFER TO YOUR COMPANY PROCEDURES.

BRAKE OVERHEAT:

- 1 – GET THE BRAKE TEMPERATURE FROM THE COCKPIT OR USE A REMOTE MEASUREMENT TECHNIQUE. THE REAL TEMPERATURE OF THE BRAKES CAN BE MUCH HIGHER THAN THE TEMPERATURE SHOWN ON THE ECAM.
NOTE: AT HIGH TEMPERATURES (>800°C), THERE IS A RISK OF WARPING OF THE LANDING GEAR STRUTS AND AXLES.
- 2 – APPROACH THE LANDING GEAR WITH EXTREME CAUTION AND FROM AN OBLIQUE ANGLE IN THE DIRECTION OF THE TIRE SHOULDER. DO NOT GO INTO THE RIM HAZARD AREA AND ONLY GO IN THE TIRE HAZARD AREA WITH CAUTION. (REF FIG. WHEEL/BRAKE OVERHEAT HAZARD AREAS). IF POSSIBLE, STAY IN A VEHICLE.
- 3 – LOOK AT THE CONDITION OF THE TIRES:
IF THE TIRES ARE STILL INFLATED (FUSE PLUGS NOT MELTED), THERE IS A RISK OF TIRE EXPLOSION AND RIM BURST. DO NOT USE COOLING FANS BECAUSE THEY CAN PREVENT OPERATION OF THE FUSE PLUGS.
- 4 – USE WATER MIST TO DECREASE THE TEMPERATURE OF THE COMPLETE WHEEL AND BRAKE ASSEMBLY. USE A TECHNIQUE THAT PREVENTS SUDDEN COOLING. SUDDEN COOLING CAN CAUSE WHEEL CRACKS OR RIM BURST. DO NOT APPLY WATER, FOAM OR CO₂. THESE COOLING AGENTS (AND ESPECIALLY CO₂, WHICH HAS A VERY STRONG COOLING EFFECT) CAN CAUSE THERMAL SHOCKS AND BURST OF HOT PARTS.

LANDING GEAR FIRE:

- CAUTION:** AIRBUS RECOMMENDS THAT YOU DO NOT USE DRY POWDERS OR DRY CHEMICALS ON HOT BRAKES OR TO EXTINGUISH LANDING GEAR FIRES. THESE AGENTS CAN CHANGE INTO SOLID OR ENAMELED DEPOSITS. THEY CAN DECREASE THE SPEED OF HEAT DISSIPATION WITH A POSSIBLE RISK OF PERMANENT STRUCTURAL DAMAGE TO THE BRAKES, WHEELS OR WHEEL AXLES.
- 1 – IMMEDIATELY STOP THE FIRE:
 - A) APPROACH THE LANDING GEAR WITH EXTREME CAUTION FROM AN OBLIQUE ANGLE IN THE DIRECTION OF THE TIRE SHOULDER. DO NOT GO INTO THE RIM HAZARD AREA AND ONLY GO IN THE TIRE HAZARD AREA WITH CAUTION. IF POSSIBLE, STAY IN A VEHICLE.
 - B) USE LARGE AMOUNTS OF WATER, WATER MIST; IF THE FUEL TANKS ARE AT RISK, USE FOAM. USE A TECHNIQUE THAT PREVENTS SUDDEN COOLING. SUDDEN COOLING CAN CAUSE WHEEL CRACKS OR RIM BURST.
 - C) DO NOT USE FANS OR BLOWERS.

F_AC_100000_1_0040102_01_00

Wheel/Brake Overheat
Recommendations (Sheet 2 of 2)
FIGURE-10-0-0-991-004 A01

**ON A/C A330-200 A330-300

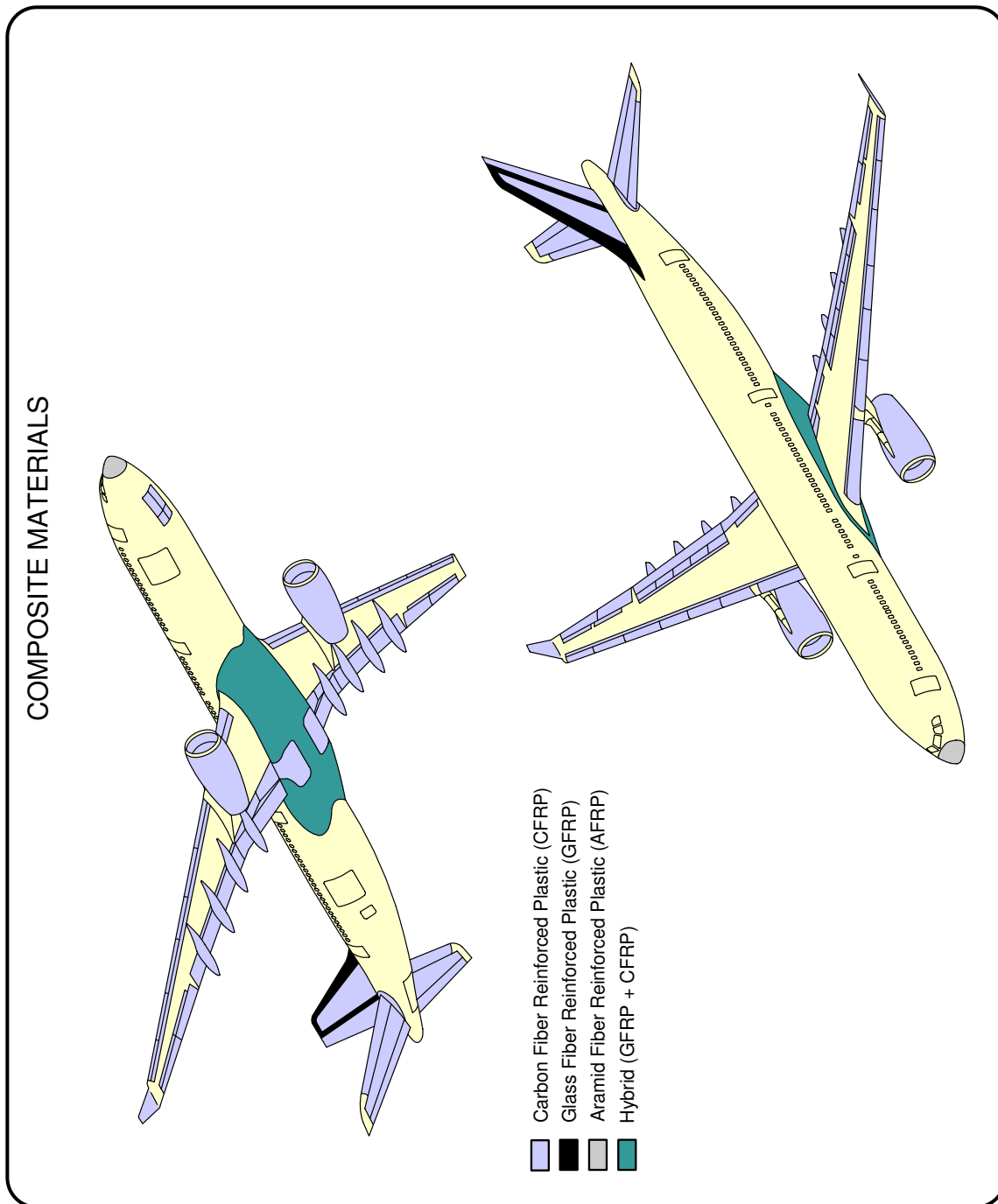

F_AC_100000_1_0050101_01_01

Composite Materials Location
FIGURE-10-0-0-991-005-A01

**ON A/C A330-200 A330-300

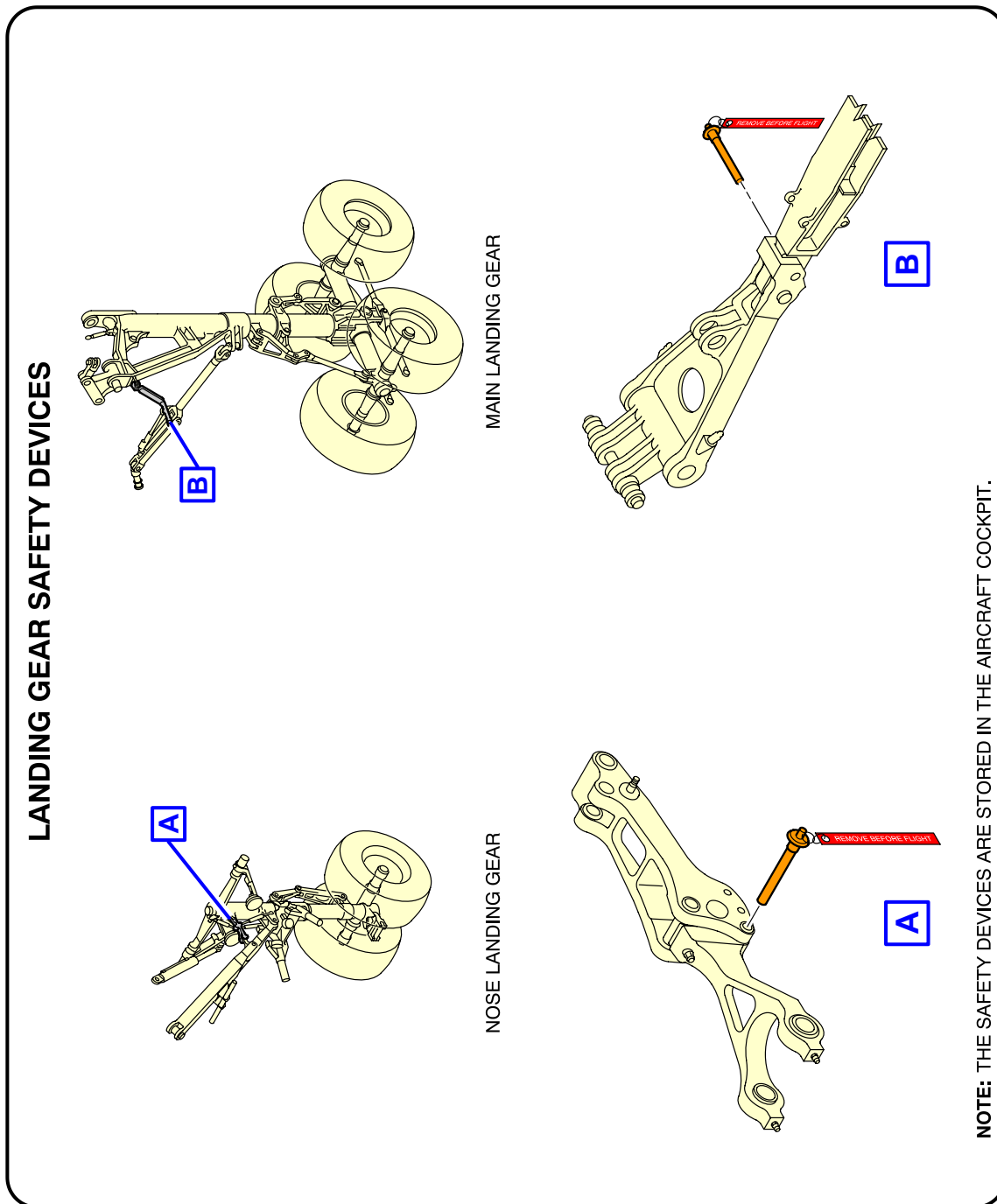

F_AC_100000_1_0060101_01_00

Ground Lock Safety Devices
FIGURE-10-0-0-991-006-A01

**ON A/C A330-200 A330-300

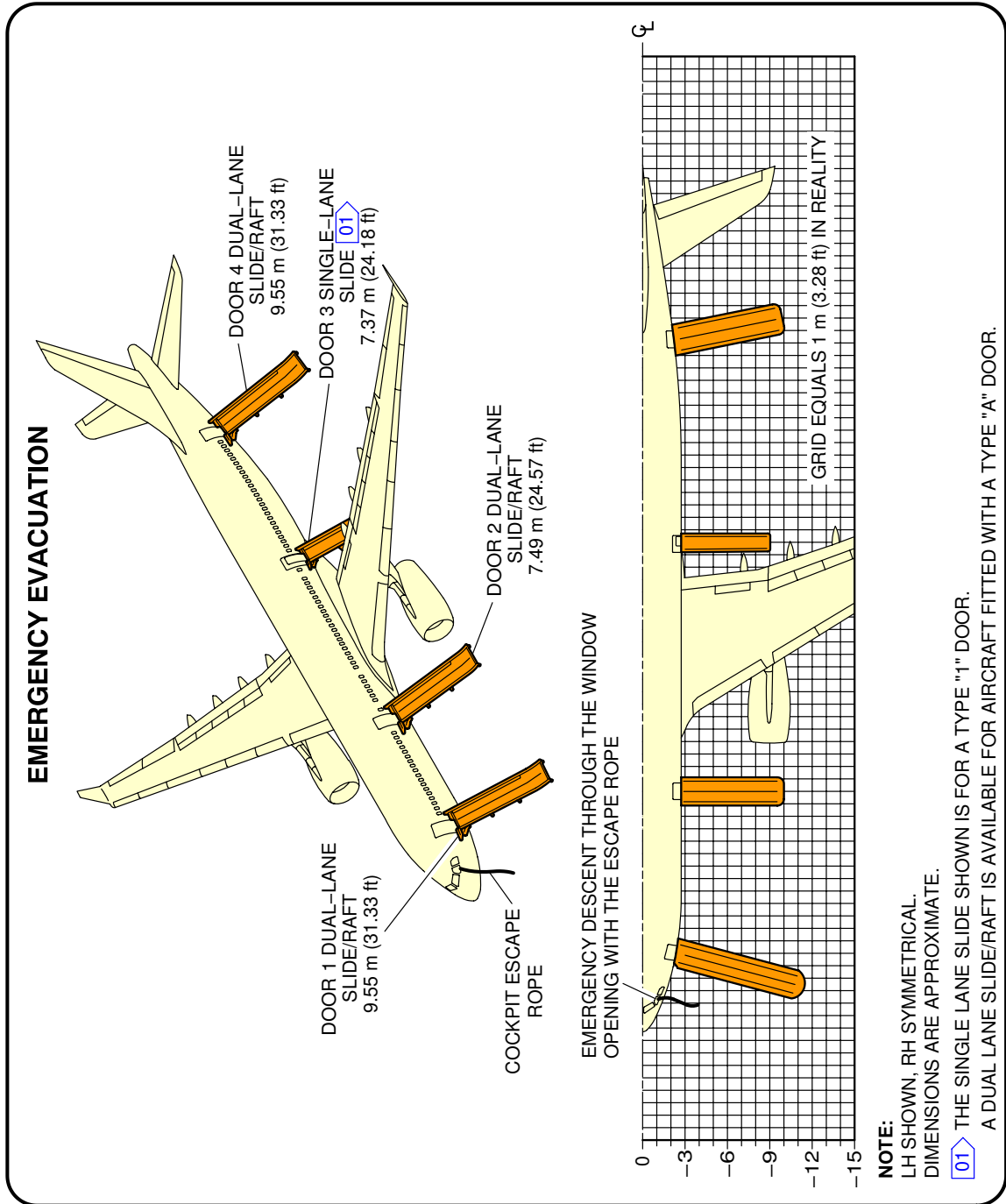

F_AC_100000_1_0070101_01_03

Emergency Evacuation Devices
FIGURE-10-0-0-991-007-A01

**ON A/C A330-200 A330-300

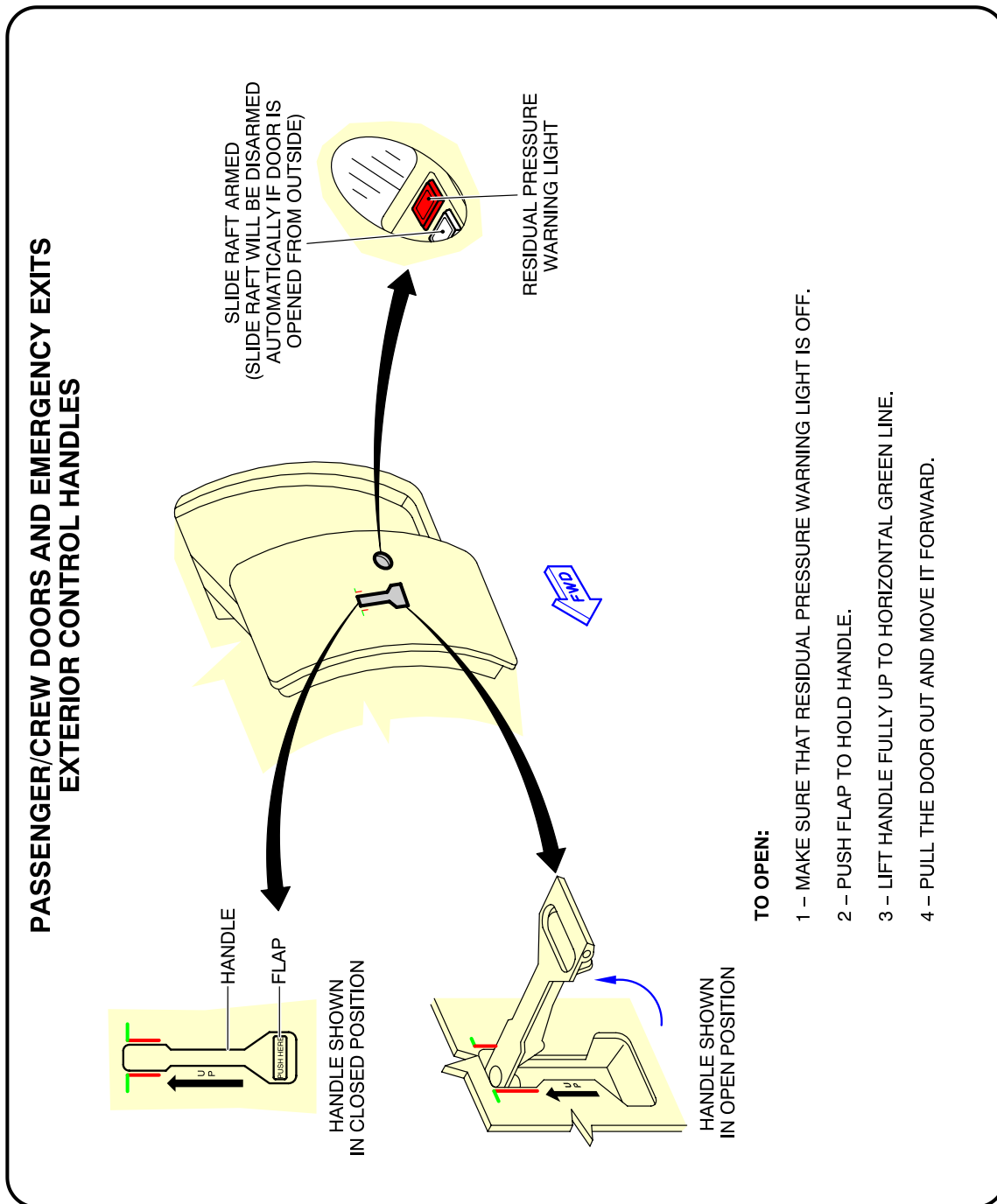

F_AC_100000_1_0080101_01_00

Pax/Crew Doors and Emergency Exits
FIGURE-10-0-0-991-008-A01

**ON A/C A330-200 A330-300

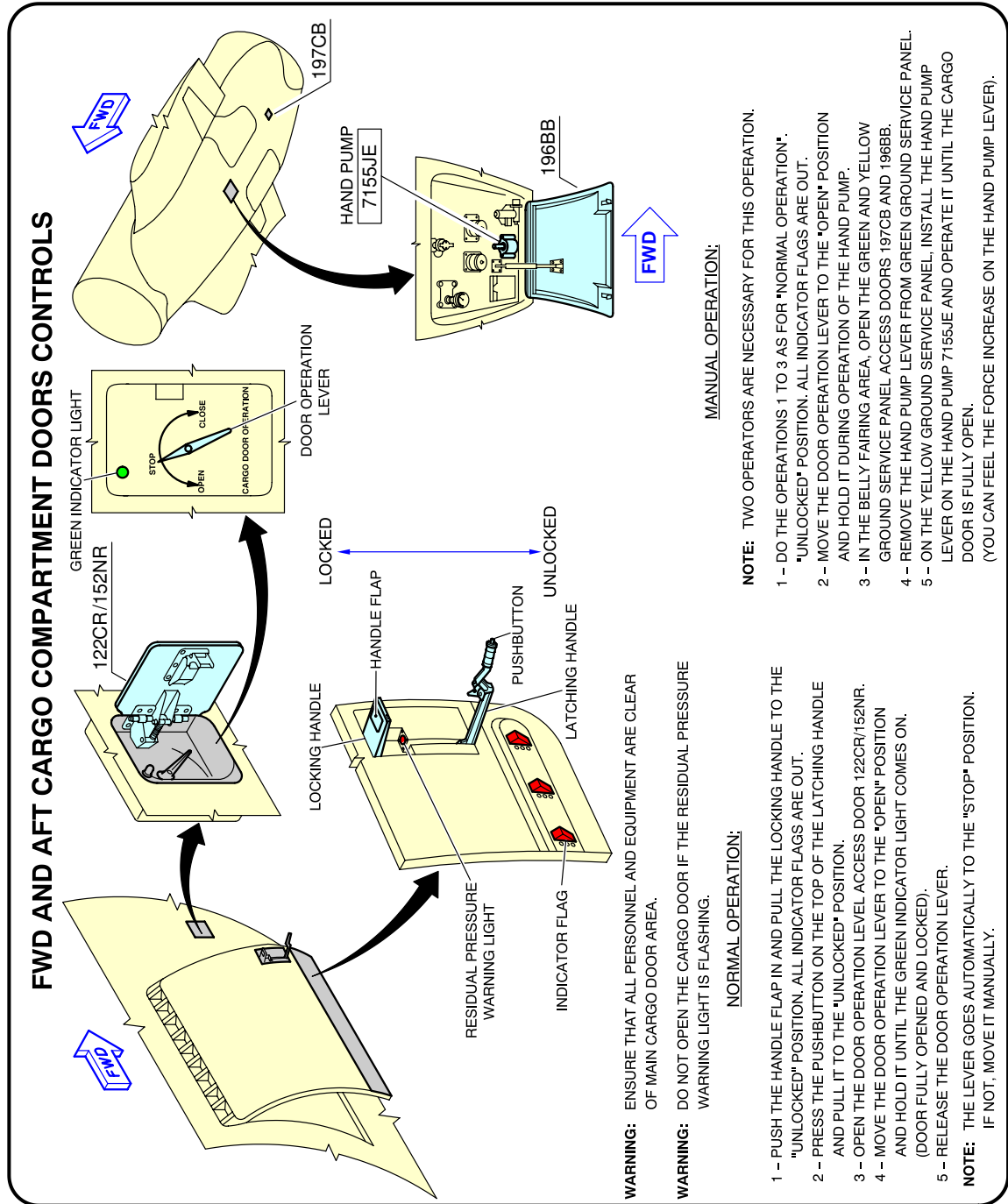

F_AC_100000_1_0090101_01_00

FWD and AFT Lower Deck Cargo Doors
FIGURE-10-0-0-991-009-A01

**ON A/C A330-200 A330-300

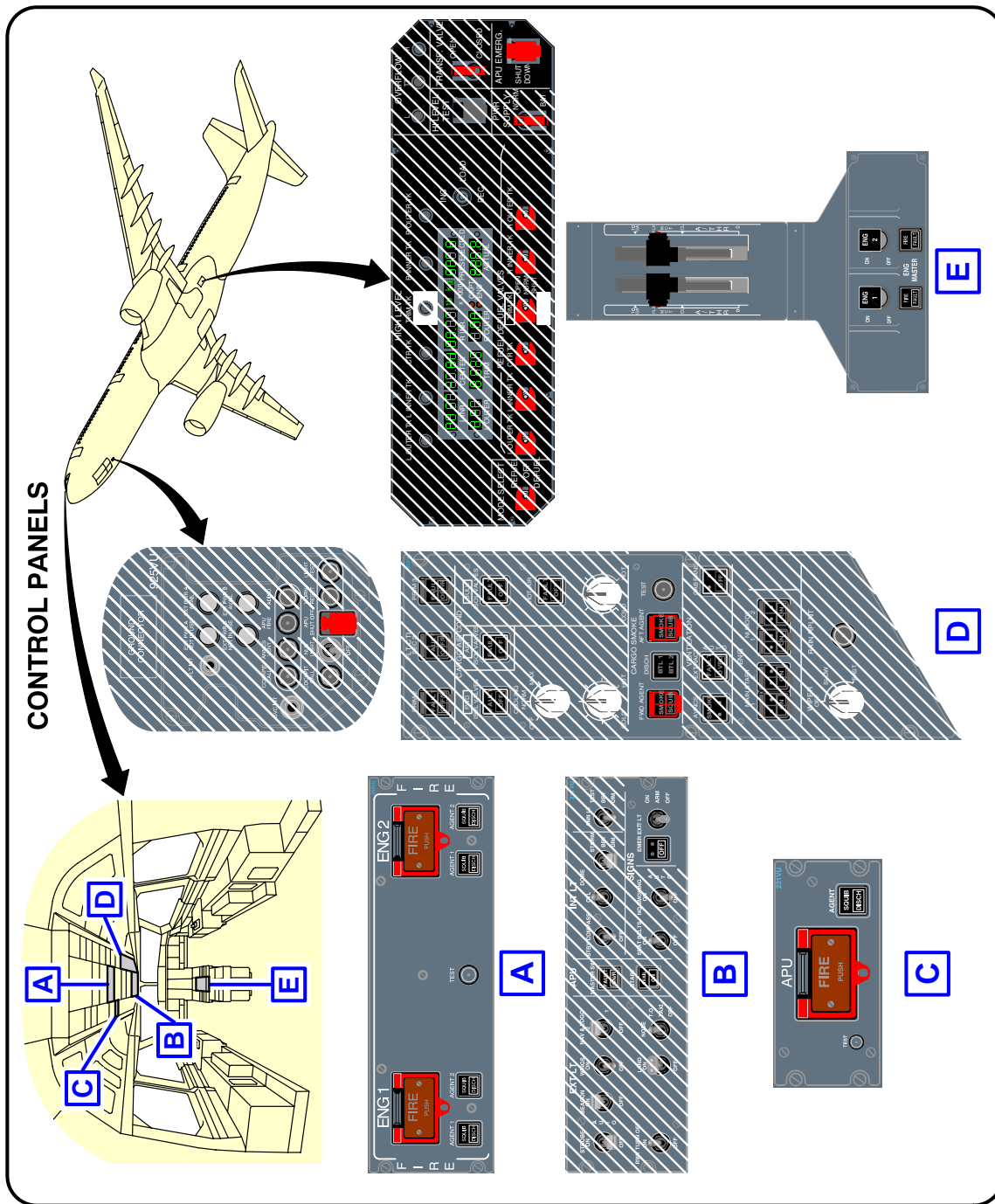

F_AC_100000_1_0100101_01_00

Control Panels
FIGURE-10-0-0-991-010-A01

**ON A/C A330-200 A330-300

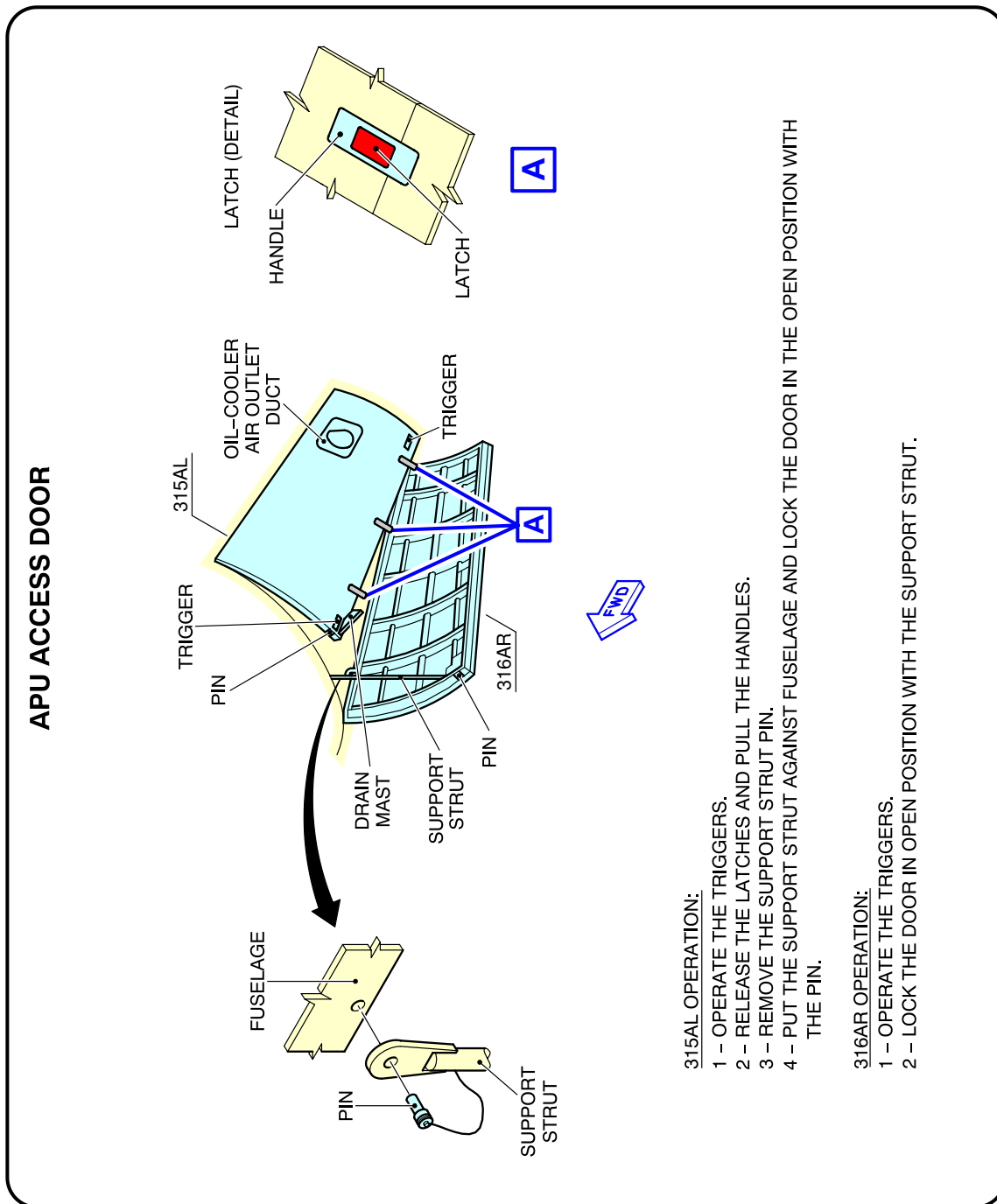

F_AC_100000_1_0110101_01_00

APU Compartment Access
FIGURE-10-0-0-991-011-A01

**ON A/C A330-200 A330-300

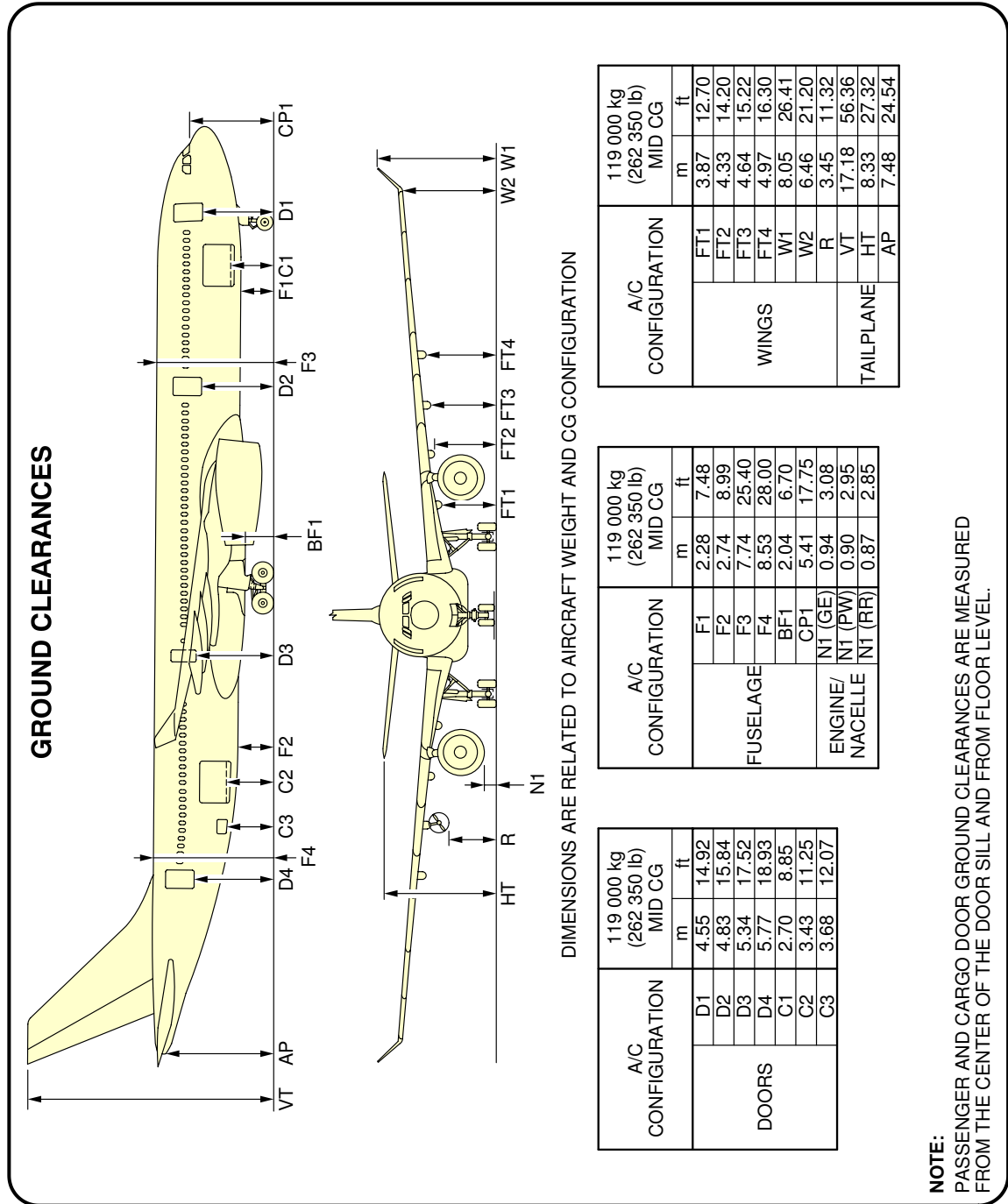

NOTE:
PASSENGER AND CARGO DOOR GROUND CLEARANCES ARE MEASURED FROM THE CENTER OF THE DOOR SILL AND FROM FLOOR LEVEL.

F_AC_100000_1_0120101_01_02

Ground Clearances
FIGURE-10-0-0-991-012-A01

**ON A/C A330-200 A330-300

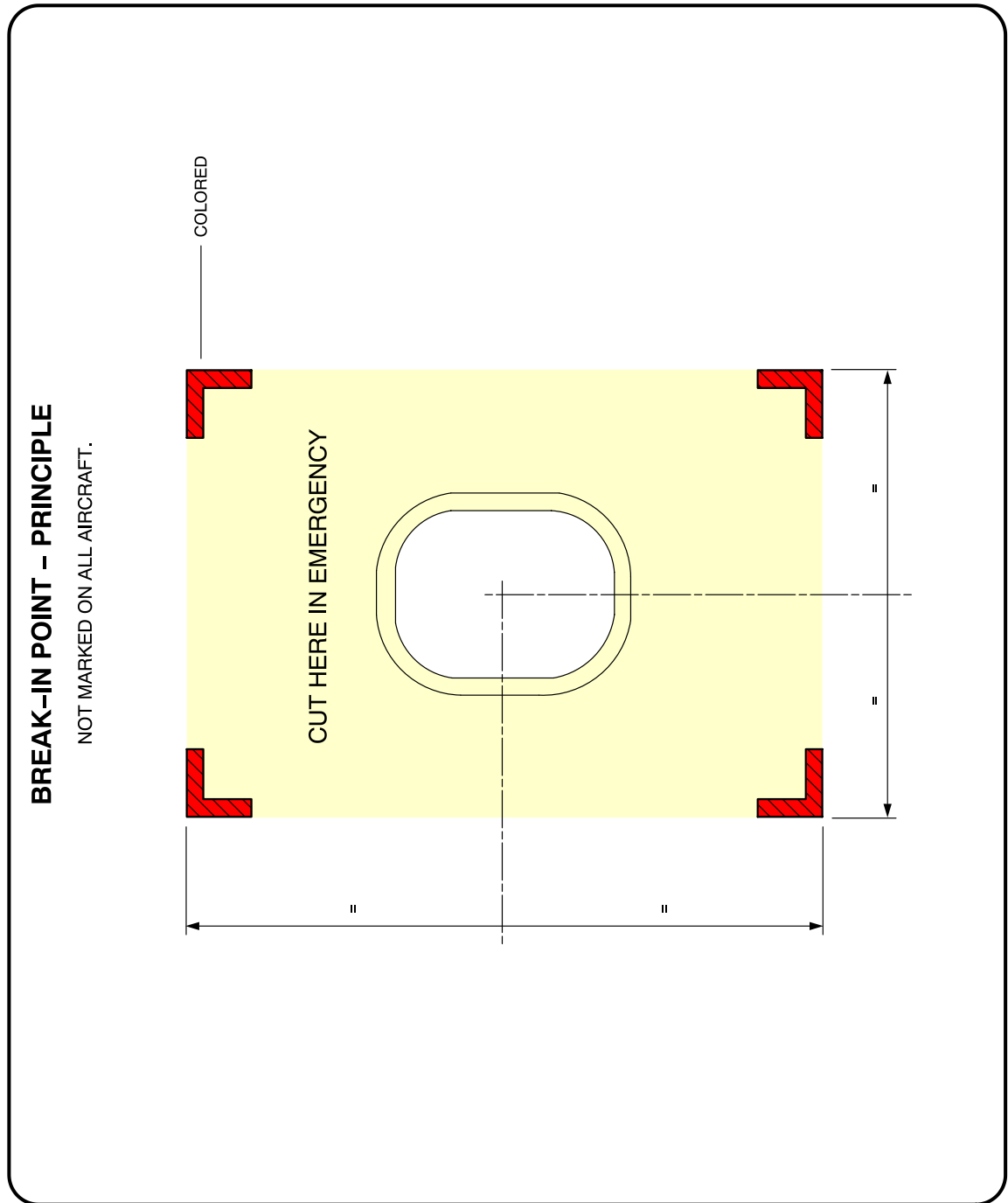

F_AC_100000_1_0130101_01_00

Structural Break-in Points
FIGURE-10-0-0-991-013-A01

****ON A/C A330-200F**

Aircraft Rescue and Fire Fighting

1. Aircraft Rescue and Fire Fighting Charts

This sections provides data related to aircraft rescue and fire fighting.

The figures contained in this section are the figures that are in the Aircraft Rescue and Fire Fighting Charts poster available for download on AIRBUSWorld and the Airbus website.

**ON A/C A330-200F



AIRBUS

A330-200F

**Aircraft Rescue and Fire Fighting Chart
ARFC**

NOTE:

THIS CHART GIVES THE GENERAL LAYOUT OF THE A330-200F STANDARD VERSION.
THE NUMBER AND ARRANGEMENT OF THE INDIVIDUAL ITEMS VARY WITH THE CUSTOMERS.
FIGURES CONTAINED IN THIS POSTER ARE AVAILABLE SEPARATLY IN THE CHAPTER 10 OF THE
"AIRCRAFT CHARACTERISTICS - AIRPORT AND MAINTENANCE PLANNING" DOCUMENT.

ISSUED BY:
AIRBUS S.A.S
CUSTOMER SERVICES
TECHNICAL DATA SUPPORT AND SERVICES
31707 BLAGNAC CEDEX
FRANCE

REVISION DATE: JULY 2018
REFERENCE : F_RF_000000_1_A33020F
SHEET 1/2

© AIRBUS S.A.S. 2013 . All rights reserved.

F_AC_100000_1_0140101_01_04

Front Page
FIGURE-10-0-0-991-014-A01

**ON A/C A330-200F

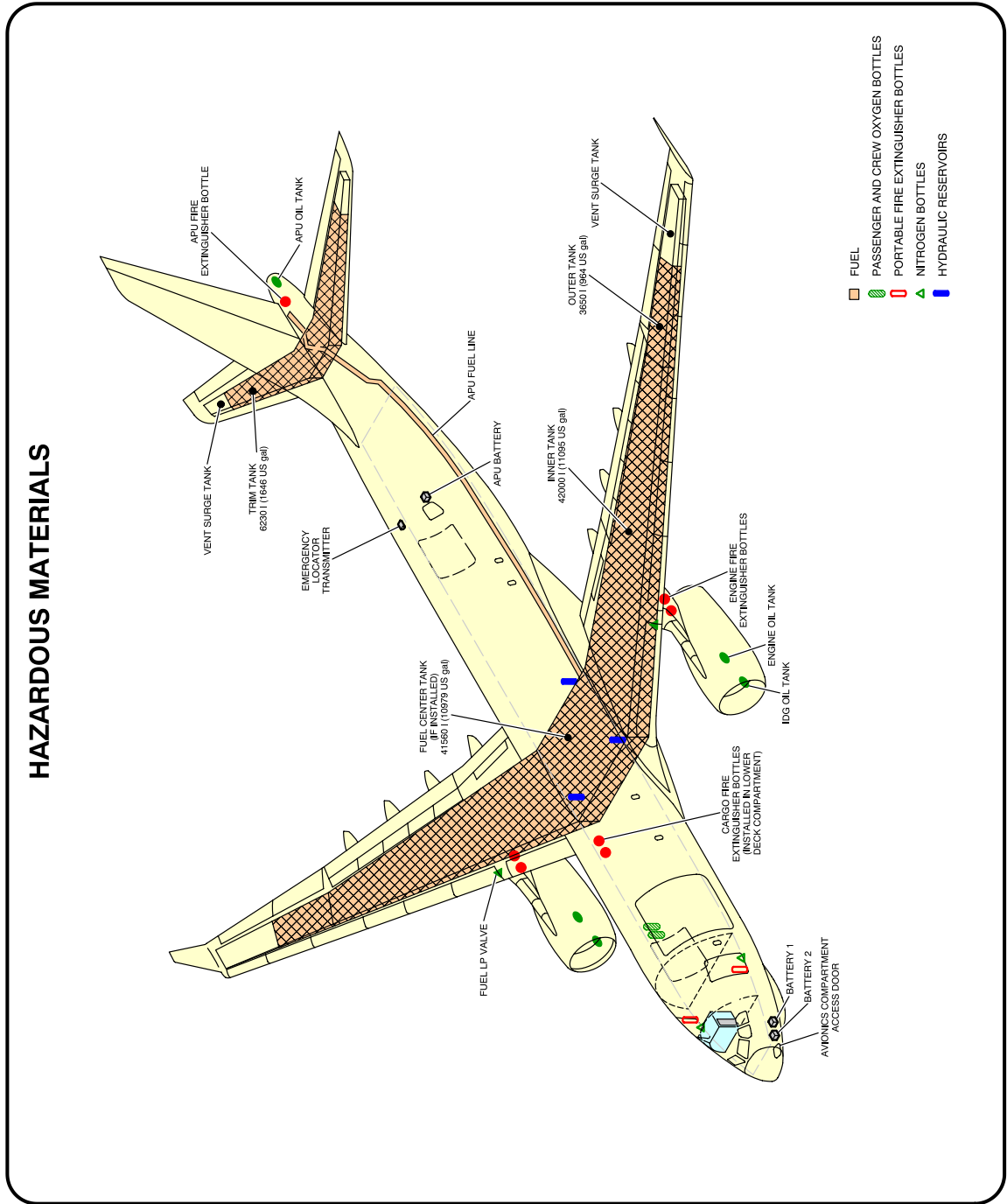

F_AC_100000_1_0150101_01_01

Highly Flammable and Hazardous Materials and Components
FIGURE-10-0-0-991-015-A01

**ON A/C A330-200F

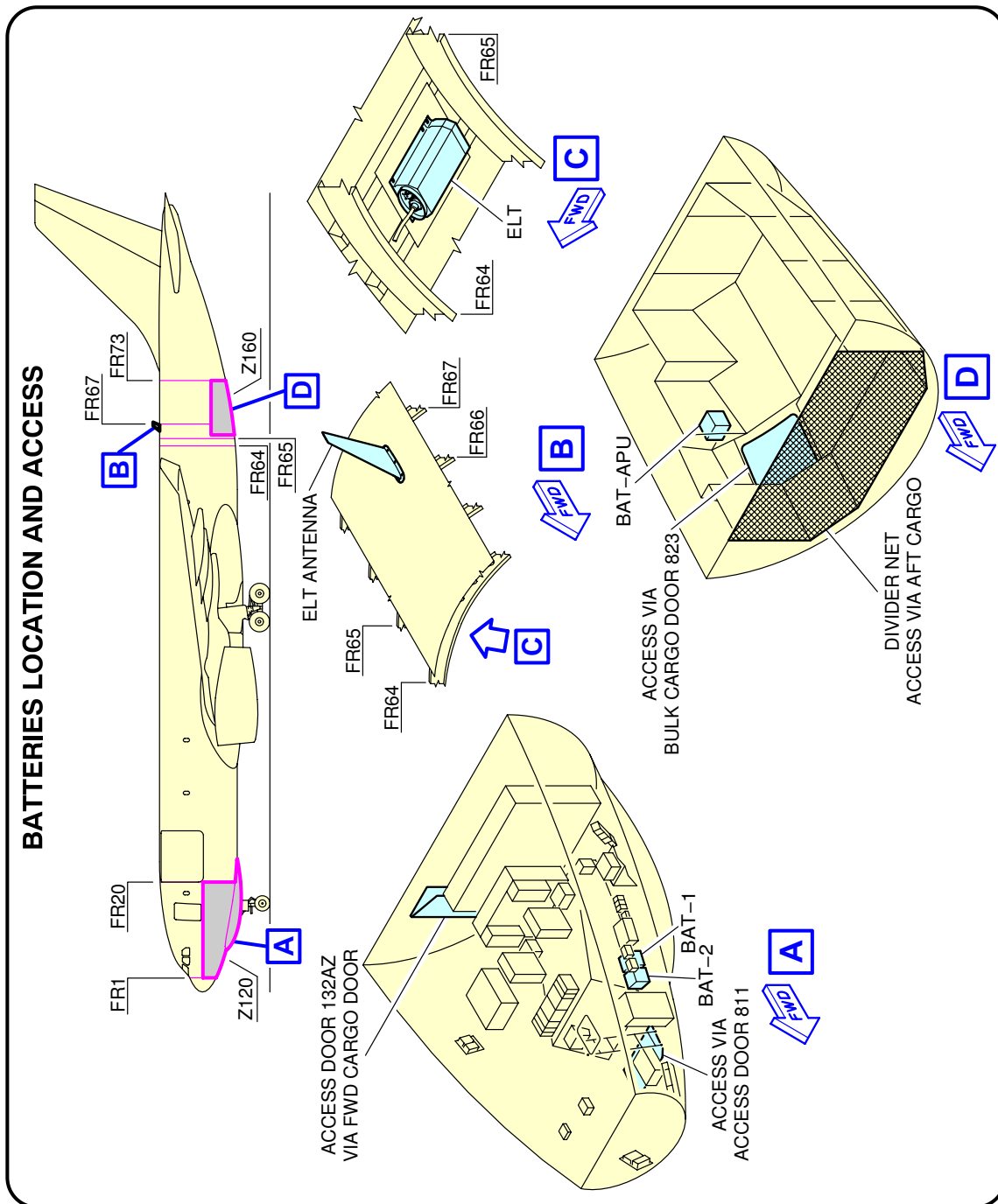

F_AC_100000_1_0680101_01_01

Batteries Location and Access
FIGURE-10-0-0-991-068-A01

**ON A/C A330-200F

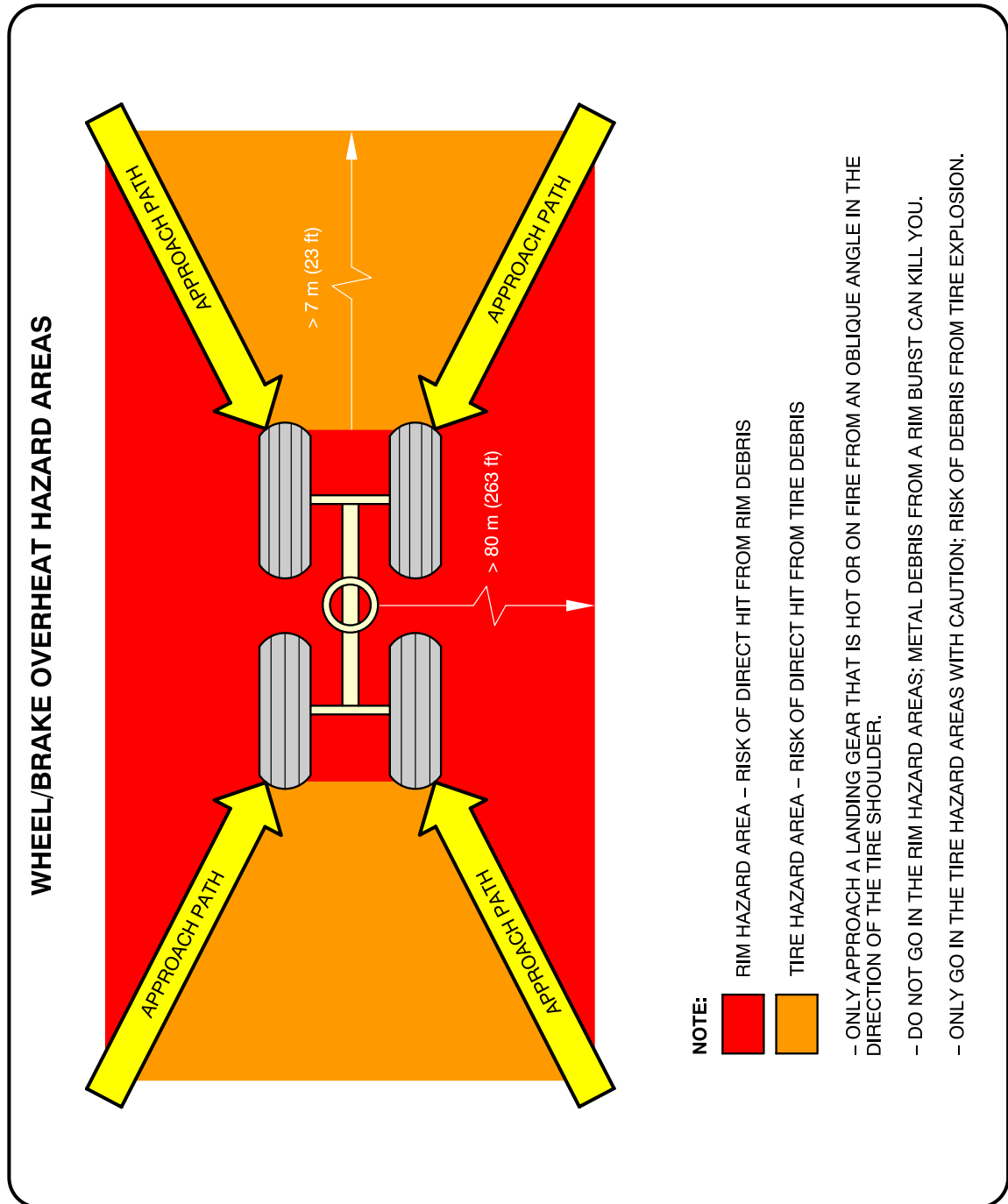

F_AC_100000_1_0160101_01_00

Wheel/Brake Overheat
Wheel Safety Area (Sheet 1 of 2)
FIGURE-10-0-0-991-016-A01

**ON A/C A330-200F

BRAKE OVERHEAT AND LANDING GEAR FIRE

WARNING: BE VERY CAREFUL WHEN THERE IS A BRAKE OVERHEAT AND/OR LANDING GEAR FIRE. THERE IS A RISK OF TIRE EXPLOSION AND/OR WHEEL RIM BURST THAT CAN CAUSE DEATH OR INJURY. MAKE SURE THAT YOU OBEY THE SAFETY PRECAUTIONS THAT FOLLOW.

THE PROCEDURES THAT FOLLOW GIVE RECOMMENDATIONS AND SAFETY PRECAUTIONS FOR THE COOLING OF VERY HOT BRAKES AFTER ABNORMAL OPERATIONS SUCH AS A REJECTED TAKE-OFF OR OVERWEIGHT LANDING. FOR THE COOLING OF BRAKES AFTER NORMAL TAXI-IN, REFER TO YOUR COMPANY PROCEDURES.

BRAKE OVERHEAT:

- 1 – GET THE BRAKE TEMPERATURE FROM THE COCKPIT OR USE A REMOTE MEASUREMENT TECHNIQUE. THE REAL TEMPERATURE OF THE BRAKES CAN BE MUCH HIGHER THAN THE TEMPERATURE SHOWN ON THE ECAM.
NOTE: AT HIGH TEMPERATURES (>800°C), THERE IS A RISK OF WARPING OF THE LANDING GEAR STRUTS AND AXLES.
- 2 – APPROACH THE LANDING GEAR WITH EXTREME CAUTION AND FROM AN OBLIQUE ANGLE IN THE DIRECTION OF THE TIRE SHOULDER. DO NOT GO INTO THE RIM HAZARD AREA AND ONLY GO IN THE TIRE HAZARD AREA WITH CAUTION. (REF FIG. WHEEL/BRAKE OVERHEAT HAZARD AREAS). IF POSSIBLE, STAY IN A VEHICLE.
- 3 – LOOK AT THE CONDITION OF THE TIRES:
IF THE TIRES ARE STILL INFLATED (FUSE PLUGS NOT MELTED), THERE IS A RISK OF TIRE EXPLOSION AND RIM BURST. DO NOT USE COOLING FANS BECAUSE THEY CAN PREVENT OPERATION OF THE FUSE PLUGS.
- 4 – USE WATER MIST TO DECREASE THE TEMPERATURE OF THE COMPLETE WHEEL AND BRAKE ASSEMBLY. USE A TECHNIQUE THAT PREVENTS SUDDEN COOLING. SUDDEN COOLING CAN CAUSE WHEEL CRACKS OR RIM BURST. DO NOT APPLY WATER, FOAM OR CO₂. THESE COOLING AGENTS (AND ESPECIALLY CO₂, WHICH HAS A VERY STRONG COOLING EFFECT) CAN CAUSE THERMAL SHOCKS AND BURST OF HOT PARTS.

LANDING GEAR FIRE:

- CAUTION:** AIRBUS RECOMMENDS THAT YOU DO NOT USE DRY POWDERS OR DRY CHEMICALS ON HOT BRAKES OR TO EXTINGUISH LANDING GEAR FIRES. THESE AGENTS CAN CHANGE INTO SOLID OR ENAMELED DEPOSITS. THEY CAN DECREASE THE SPEED OF HEAT DISSIPATION WITH A POSSIBLE RISK OF PERMANENT STRUCTURAL DAMAGE TO THE BRAKES, WHEELS OR WHEEL AXLES.
- 1 – IMMEDIATELY STOP THE FIRE:
 - A) APPROACH THE LANDING GEAR WITH EXTREME CAUTION FROM AN OBLIQUE ANGLE IN THE DIRECTION OF THE TIRE SHOULDER. DO NOT GO INTO THE RIM HAZARD AREA AND ONLY GO IN THE TIRE HAZARD AREA WITH CAUTION. IF POSSIBLE, STAY IN A VEHICLE.
 - B) USE LARGE AMOUNTS OF WATER, WATER MIST; IF THE FUEL TANKS ARE AT RISK, USE FOAM. USE A TECHNIQUE THAT PREVENTS SUDDEN COOLING. SUDDEN COOLING CAN CAUSE WHEEL CRACKS OR RIM BURST.
 - C) DO NOT USE FANS OR BLOWERS.

F_AC_100000_1_0160102_01_00

Wheel/Brake Overheat
Recommendations (Sheet 2 of 2)
FIGURE-10-0-0-991-016-A01

**ON A/C A330-200F

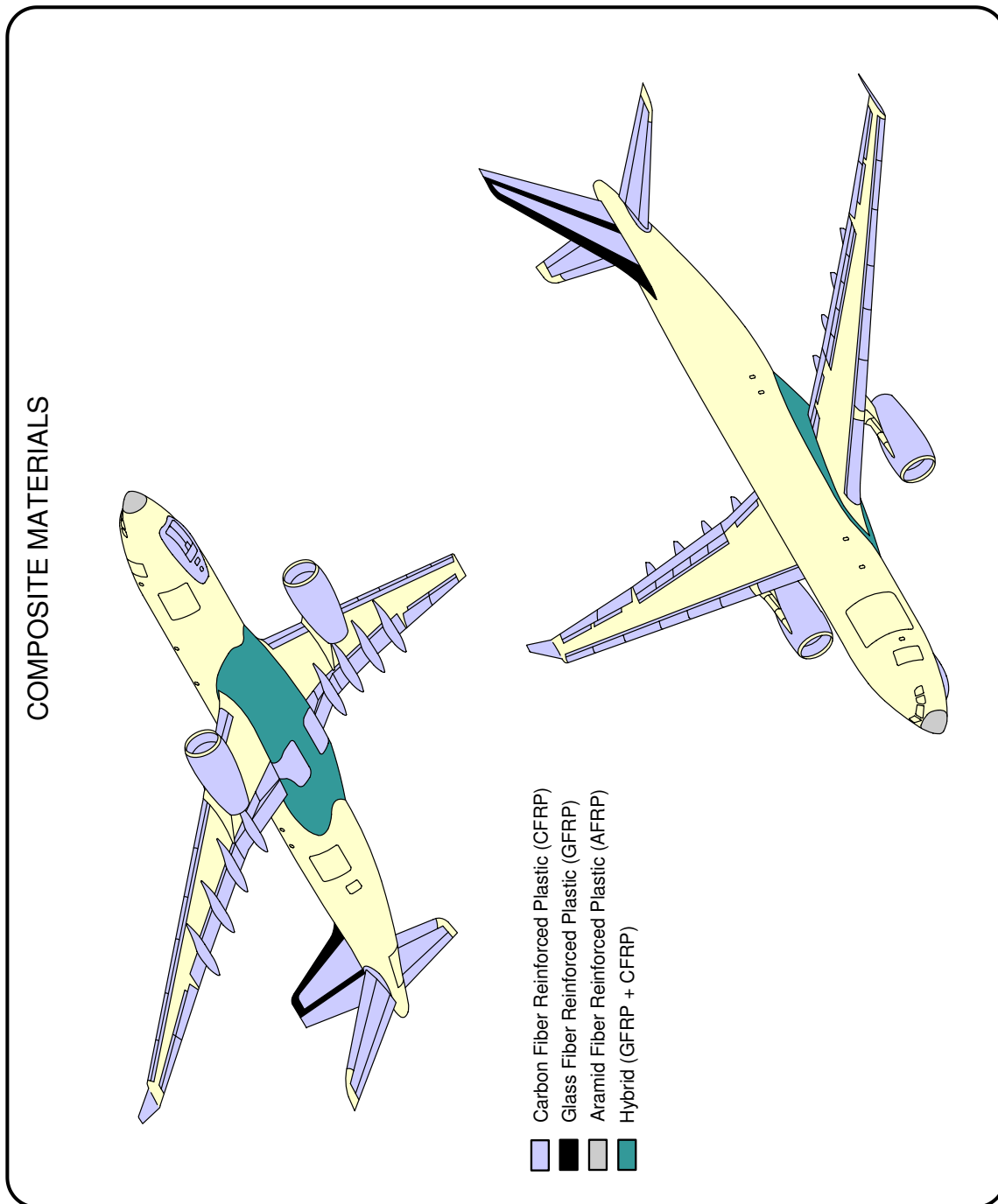

F_AC_100000_1_0180101_01_01

Composite Materials Location
FIGURE-10-0-0-991-018-A01

**ON A/C A330-200F

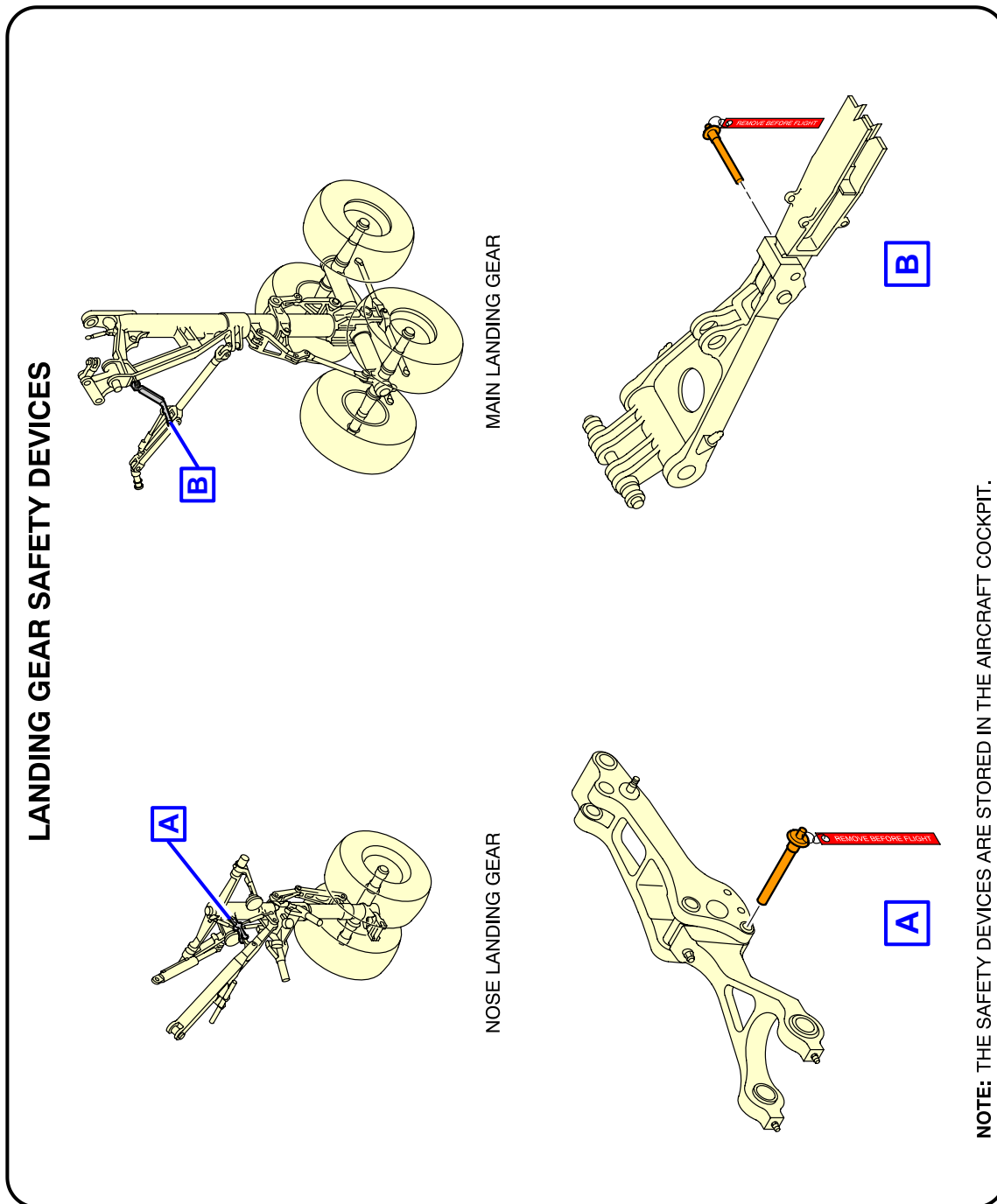

F_AC_100000_1_0190101_01_00

Ground Lock Safety Devices
FIGURE-10-0-0-991-019-A01

**ON A/C A330-200F

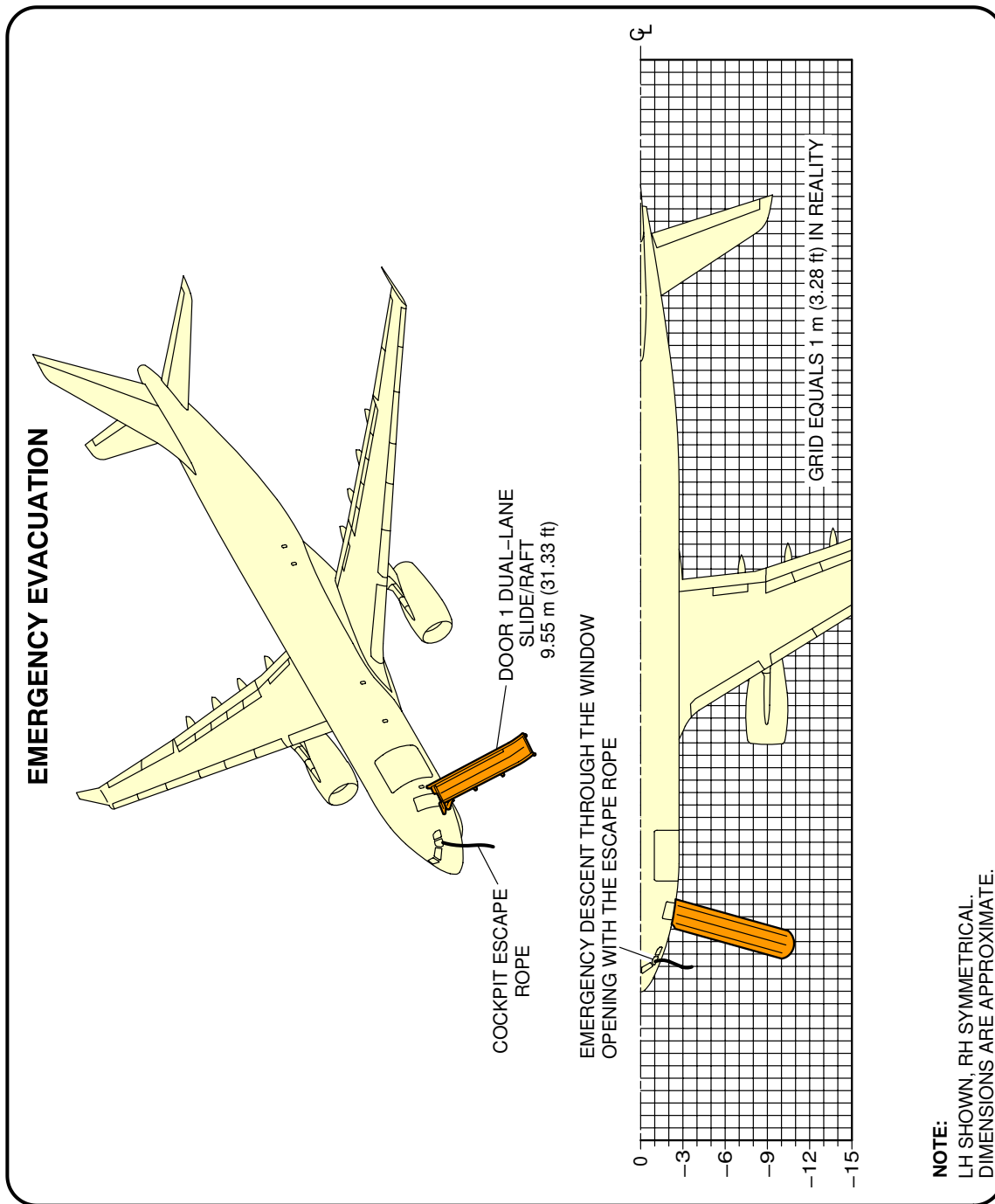

F_AC_100000_1_0200101_01_03

Emergency Evacuation Devices
FIGURE-10-0-0-991-020-A01

**ON A/C A330-200F

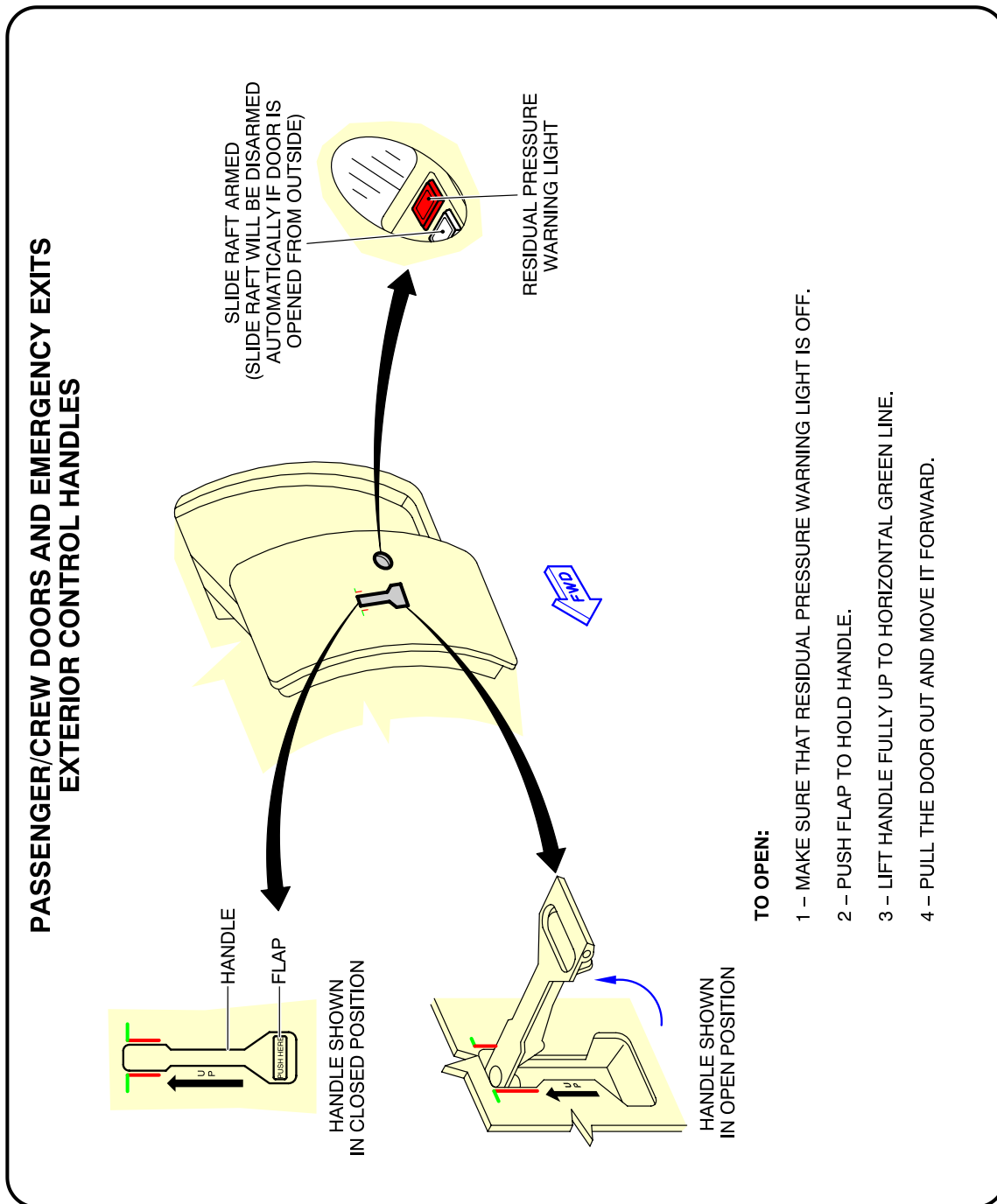

F_AC_100000_1_0210101_01_00

Crew Doors and Emergency Exits
FIGURE-10-0-0-991-021-A01

**ON A/C A330-200F

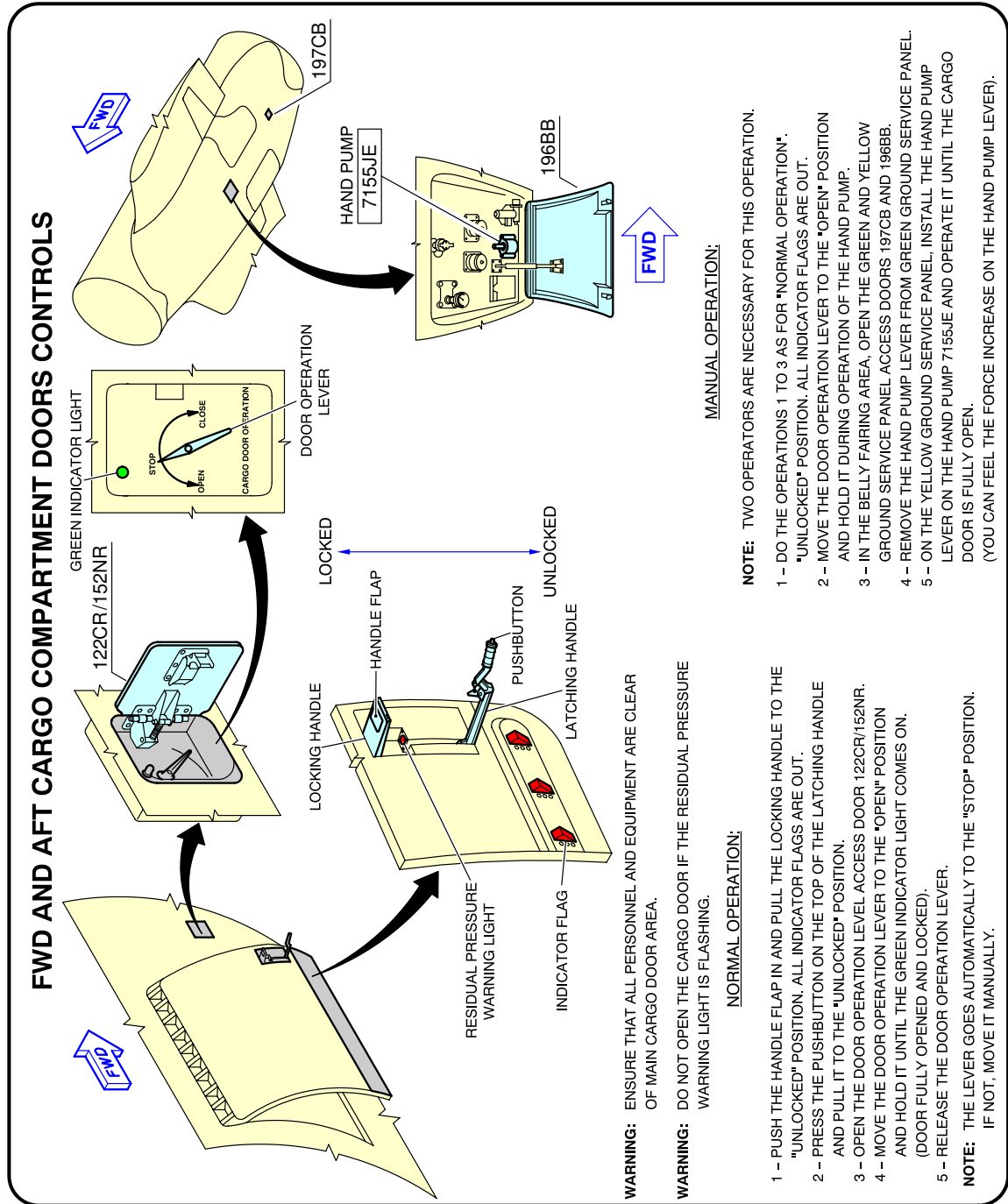

F_AC_100000_1_0220101_01_00

Cargo Doors
FWD and AFT Lower Deck Compartments (Sheet 1 of 2)
FIGURE-10-0-0-991-022-A01

**ON A/C A330-200F

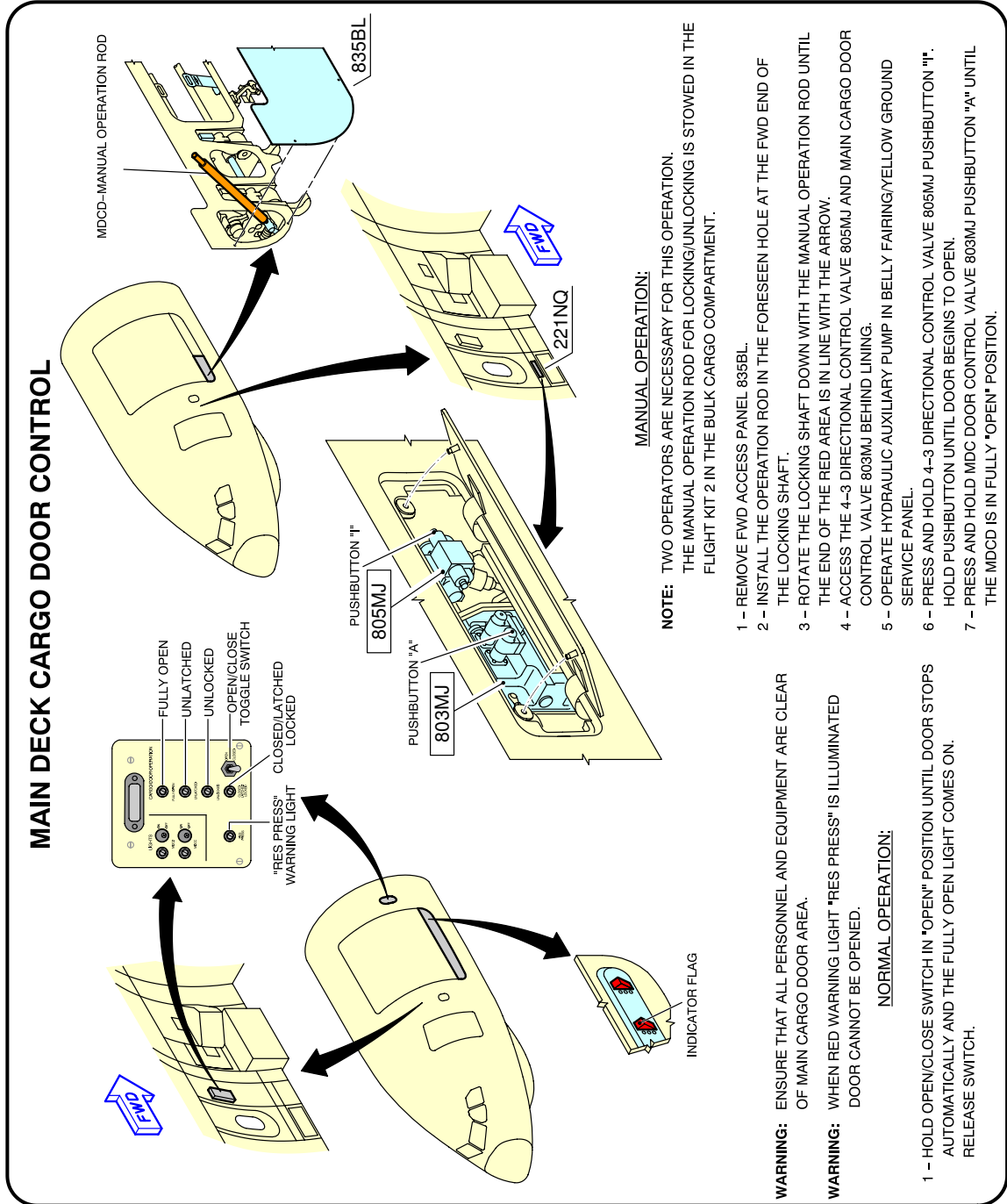

F_AC_100000_1_0220102_01_00

Cargo Doors
Upper Deck Compartment (Sheet 2 of 2)
FIGURE-10-0-0-991-022-A01

**ON A/C A330-200F

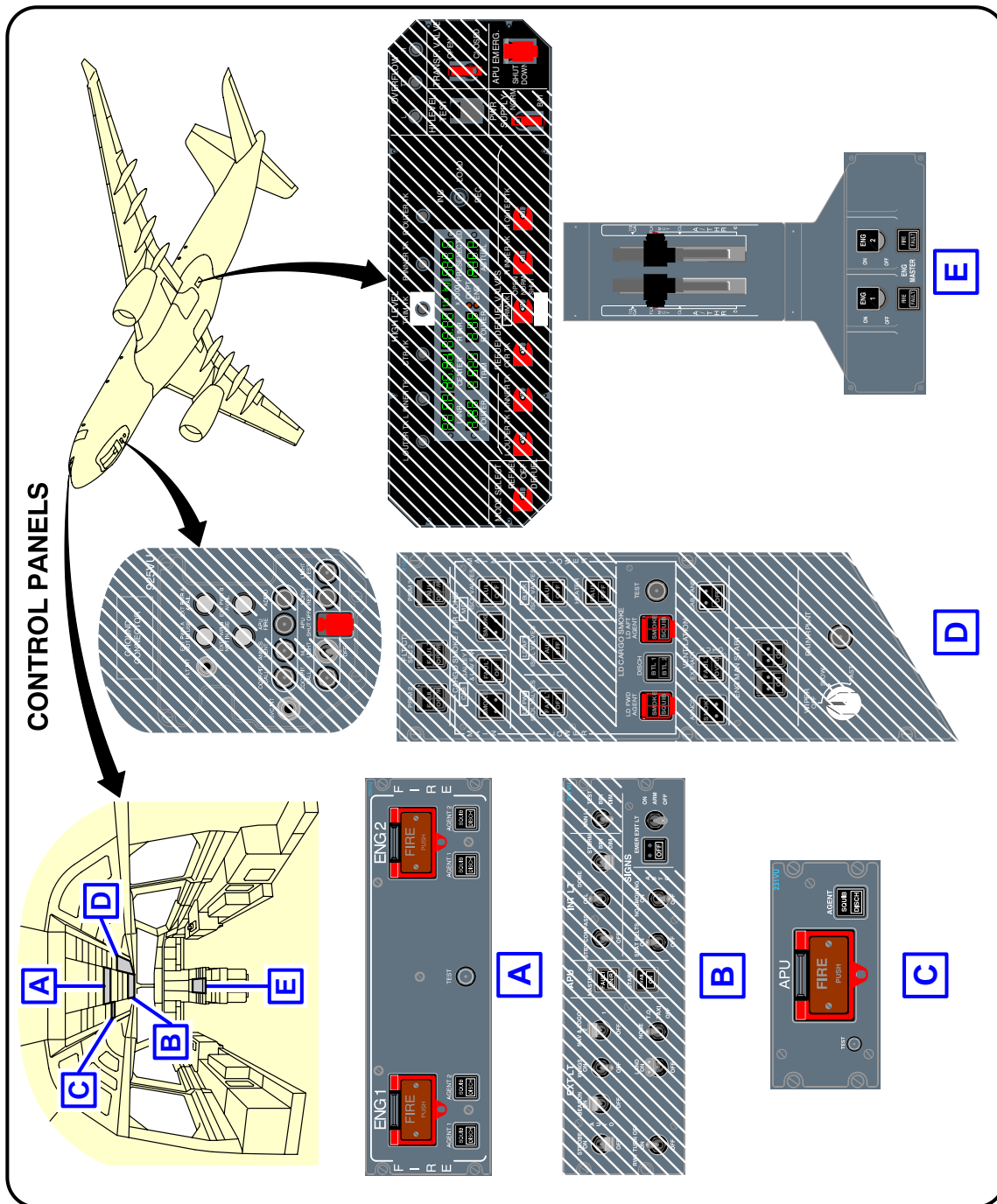

F_AC_100000_1_0230101_01_00

Control Panels
FIGURE-10-0-0-991-023-A01

**ON A/C A330-200F

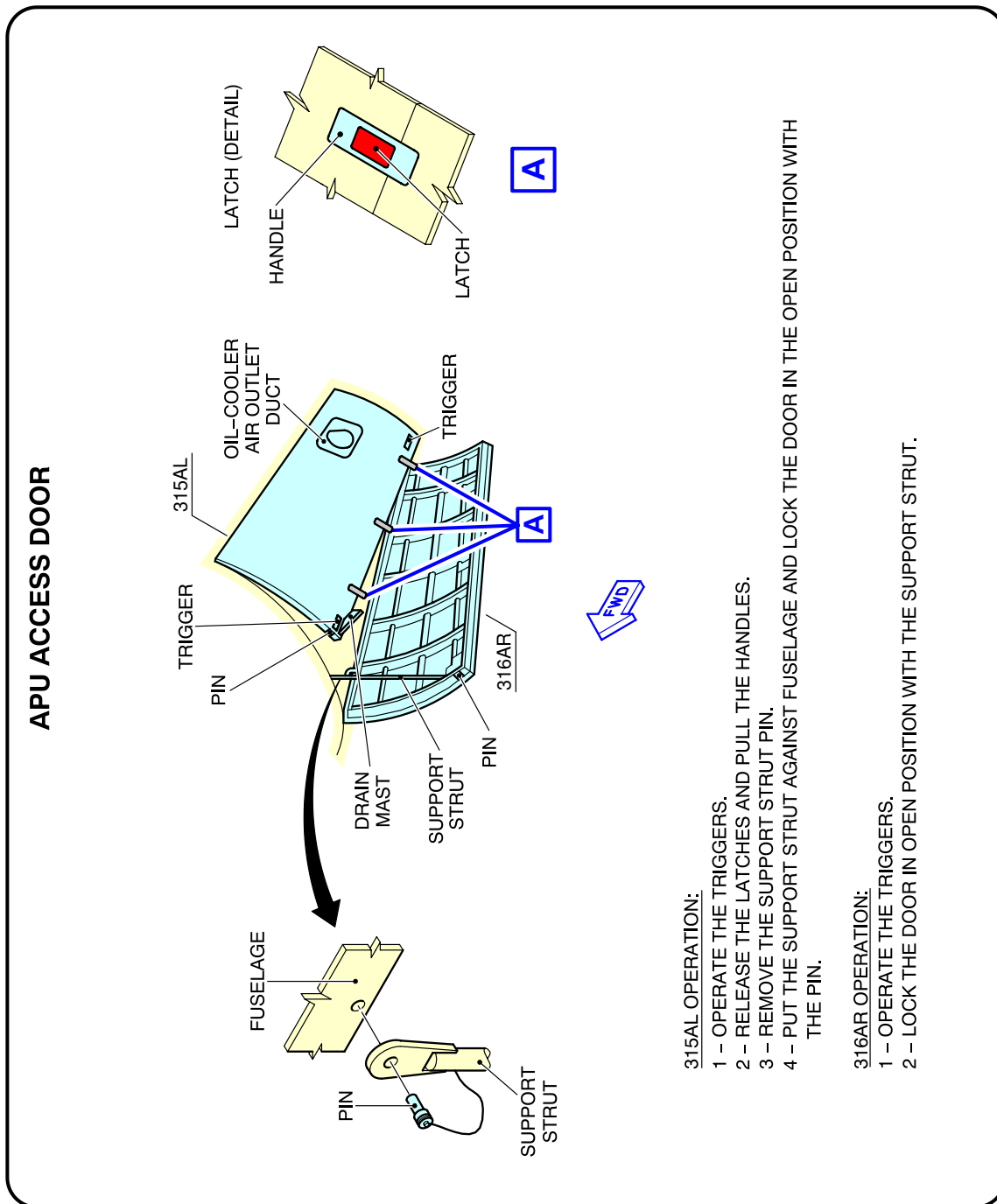

F_AC_100000_1_0240101_01_00

APU Compartment Access
FIGURE-10-0-0-991-024-A01

**ON A/C A330-200F

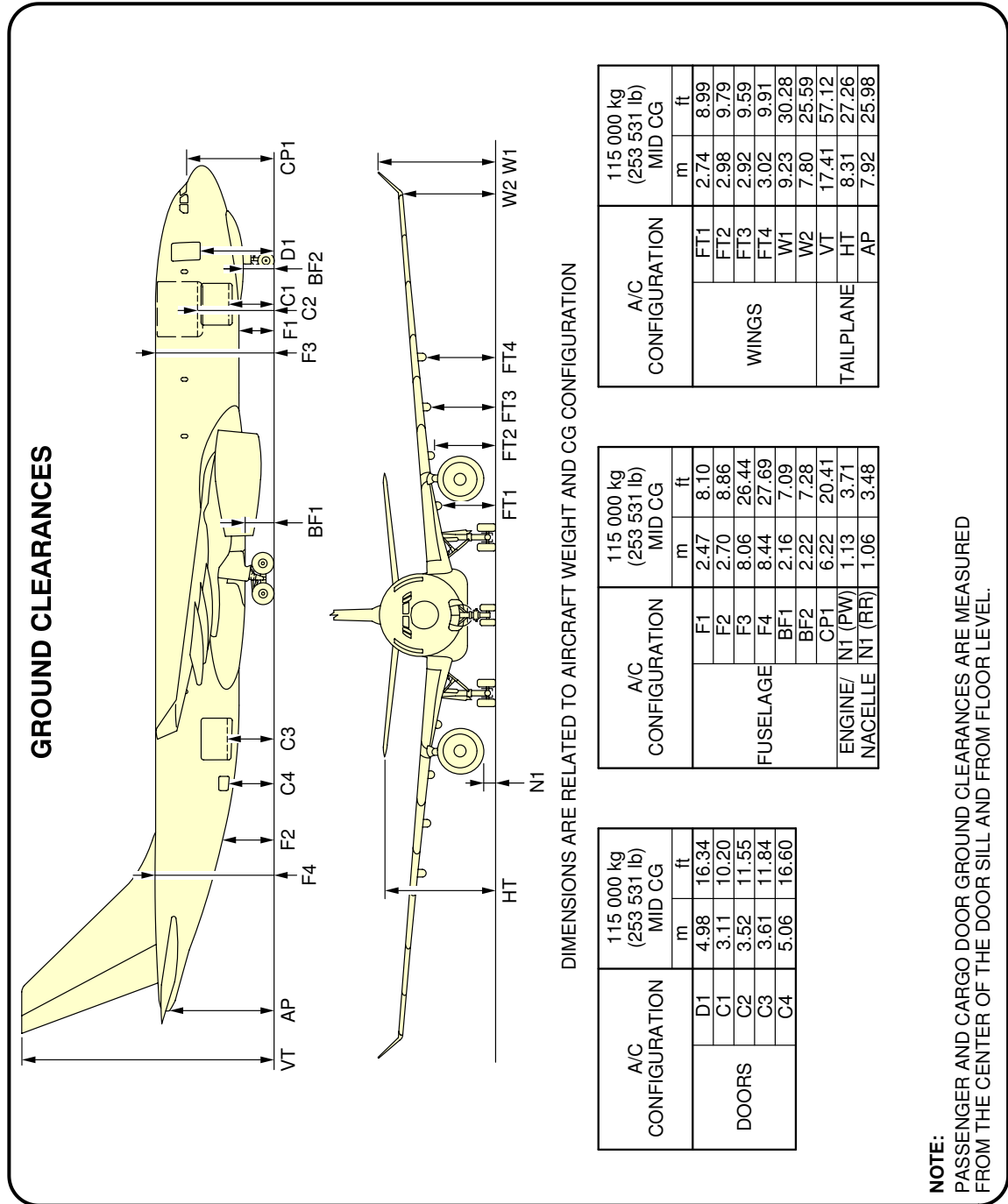

F_AC_100000_1_0250101_01_02

Ground Clearances
FIGURE-10-0-0-991-025-A01

**ON A/C A330-200F

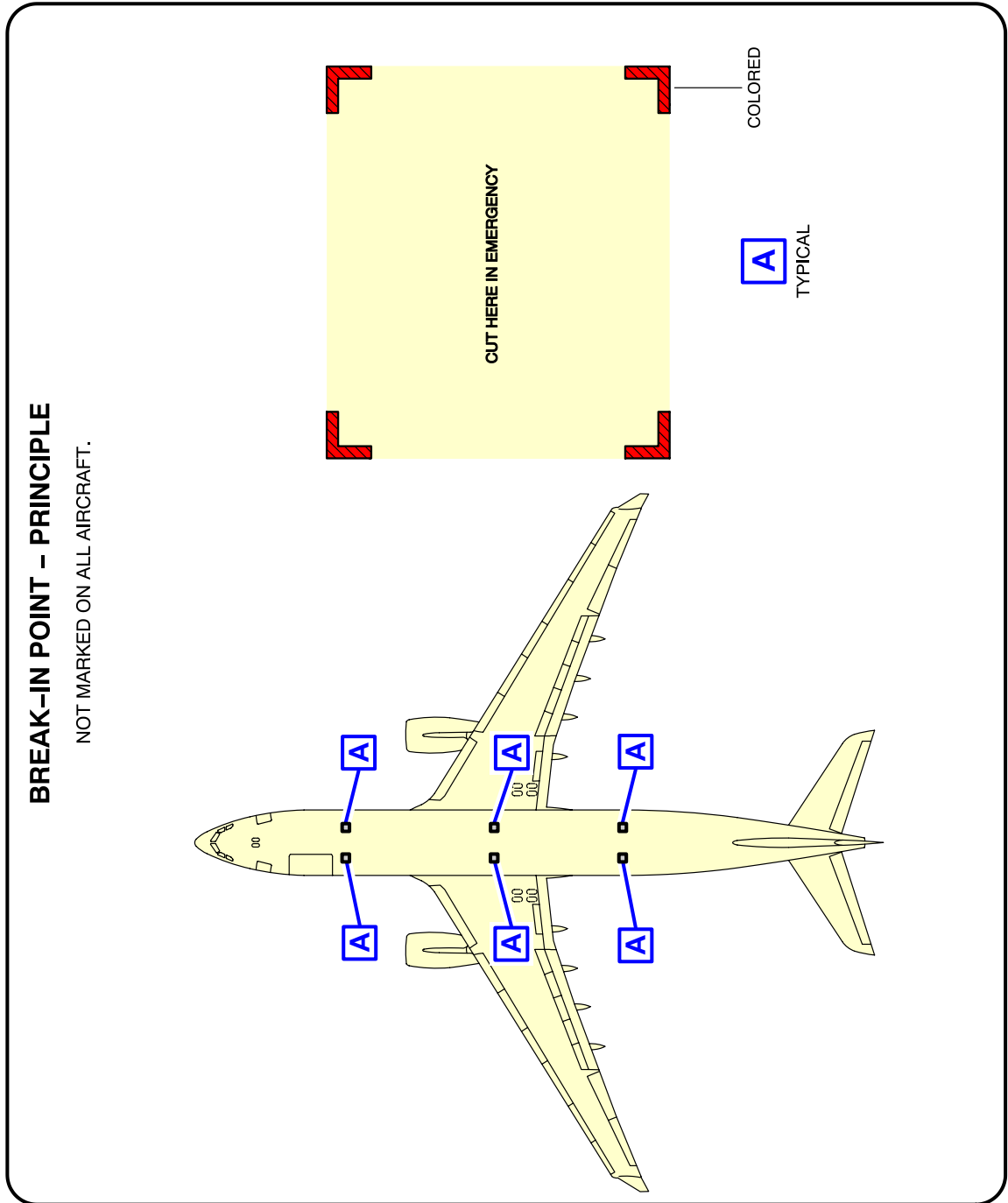

F_AC_100000_1_0260101_01_01

Structural Break-in Points
FIGURE-10-0-0-991-026-A01

****ON A/C A330-800 A330-900**

Aircraft Rescue and Fire Fighting

1. Aircraft Rescue and Fire Fighting Charts

This sections provides data related to aircraft rescue and fire fighting.

The figures contained in this section are the figures that are in the Aircraft Rescue and Fire Fighting Charts poster available for download on AIRBUSWorld and the Airbus website.

**ON A/C A330-800 A330-900



AIRBUS

A330-800/-900

Aircraft Rescue and Fire Fighting Chart ARFC

NOTE:

THIS CHART GIVES THE GENERAL LAYOUT OF THE A330-800 AND A330-900 STANDARD VERSION.
THE NUMBER AND ARRANGEMENT OF THE INDIVIDUAL ITEMS VARY WITH THE CUSTOMERS.
FIGURES CONTAINED IN THIS POSTER ARE AVAILABLE SEPARATLY IN THE CHAPTER 10 OF THE
"AIRCRAFT CHARACTERISTICS - AIRPORT AND MAINTENANCE PLANNING" DOCUMENT.

ISSUED BY:
AIRBUS S.A.S
CUSTOMER SERVICES
TECHNICAL DATA SUPPORT AND SERVICES
31707 BLAGNAC CEDEX
FRANCE

REVISION DATE: JULY 2018
REFERENCE : F_RF_000000_1_A338090
SHEET 1/2

© AIRBUS S.A.S. 2013 . All rights reserved.

F_AC_100000_1_0720101_01_01

Front Page
FIGURE-10-0-0-991-072-A01

**ON A/C A330-800 A330-900

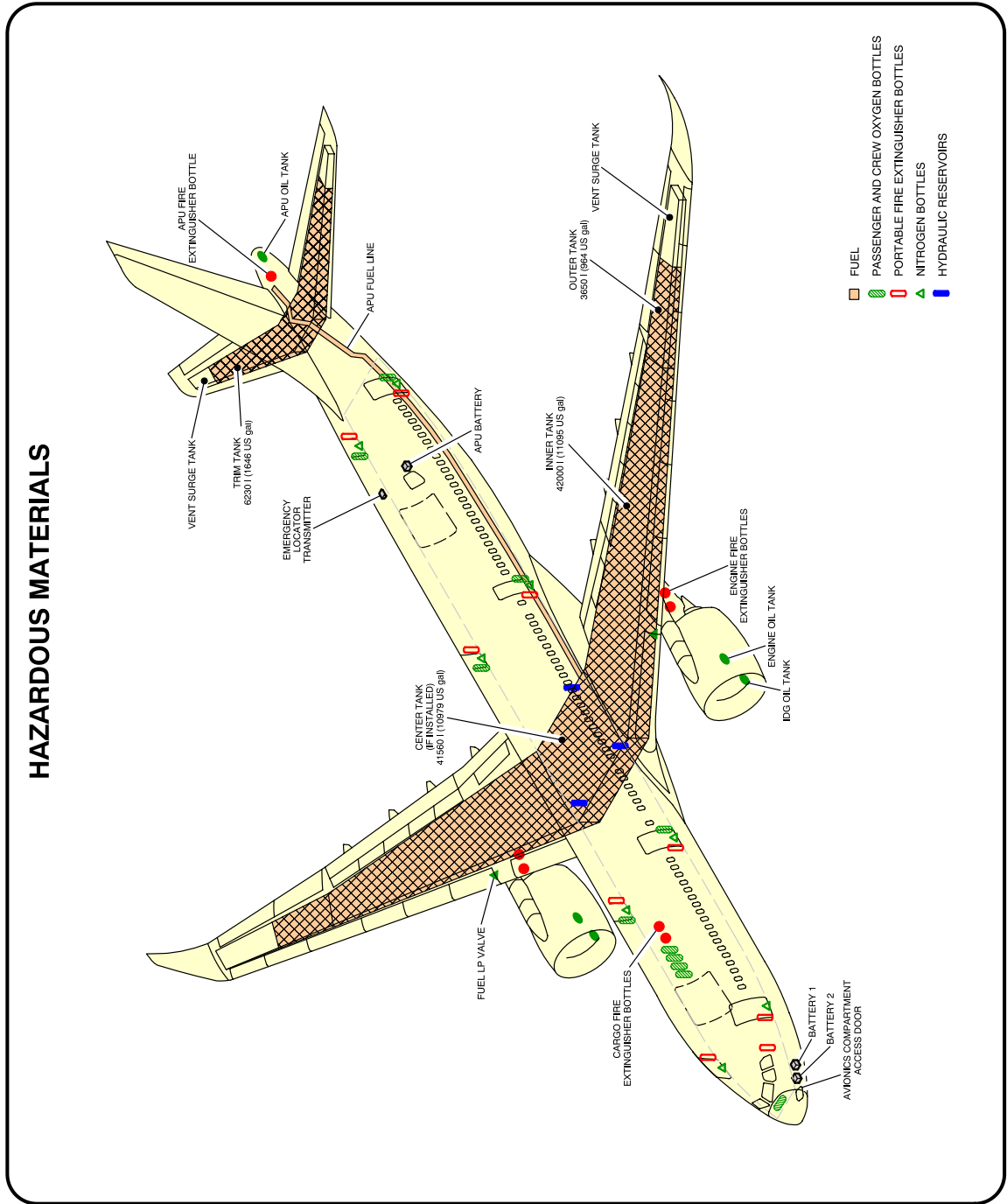

F_AC_100000_1_0730101_01_00

Highly Flammable and Hazardous Materials and Components
FIGURE-10-0-0-991-073-A01

**ON A/C A330-800 A330-900

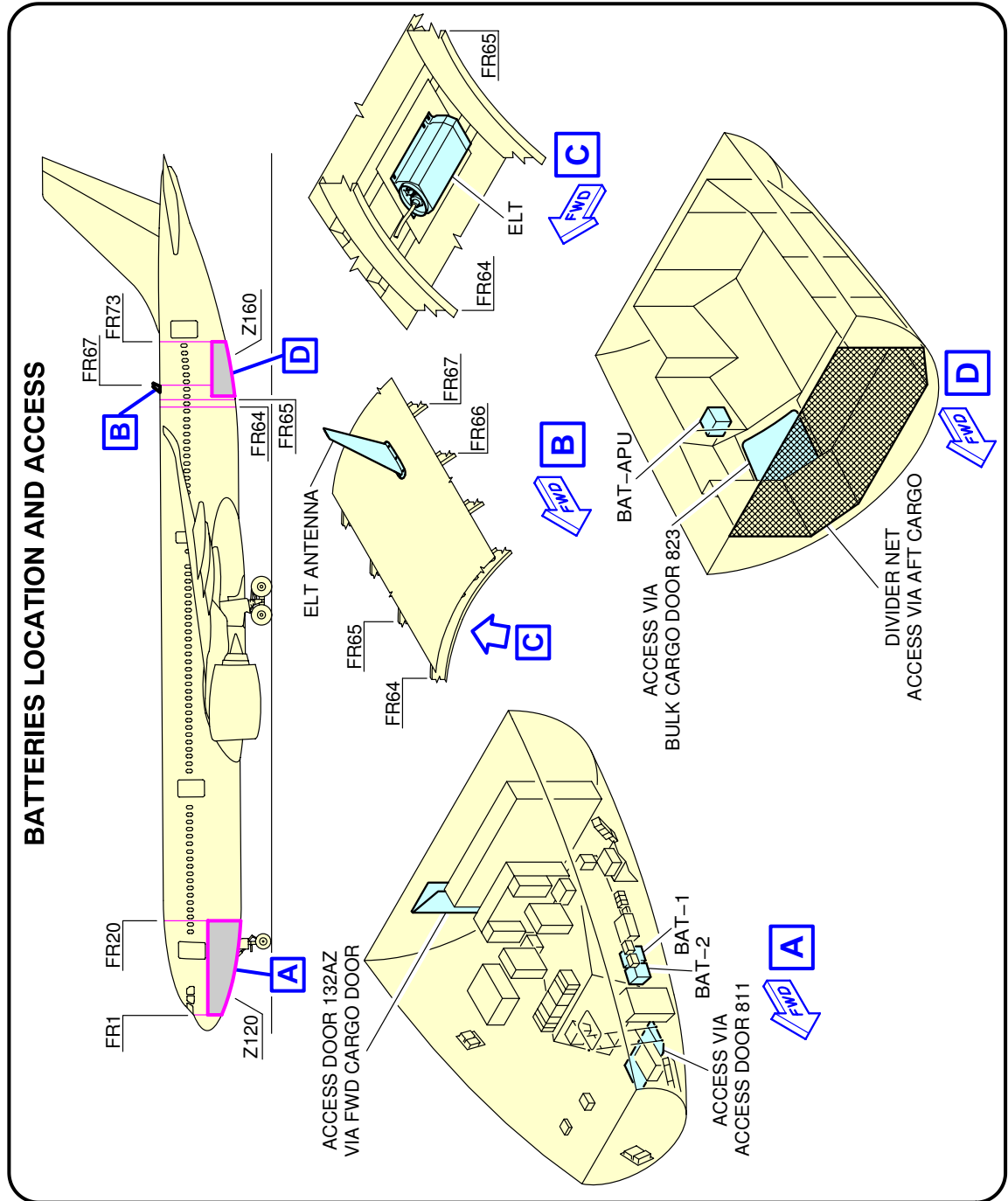

F_AC_100000_1_0740101_01_00

Batteries Location and Access
FIGURE-10-0-0-991-074-A01

**ON A/C A330-800 A330-900

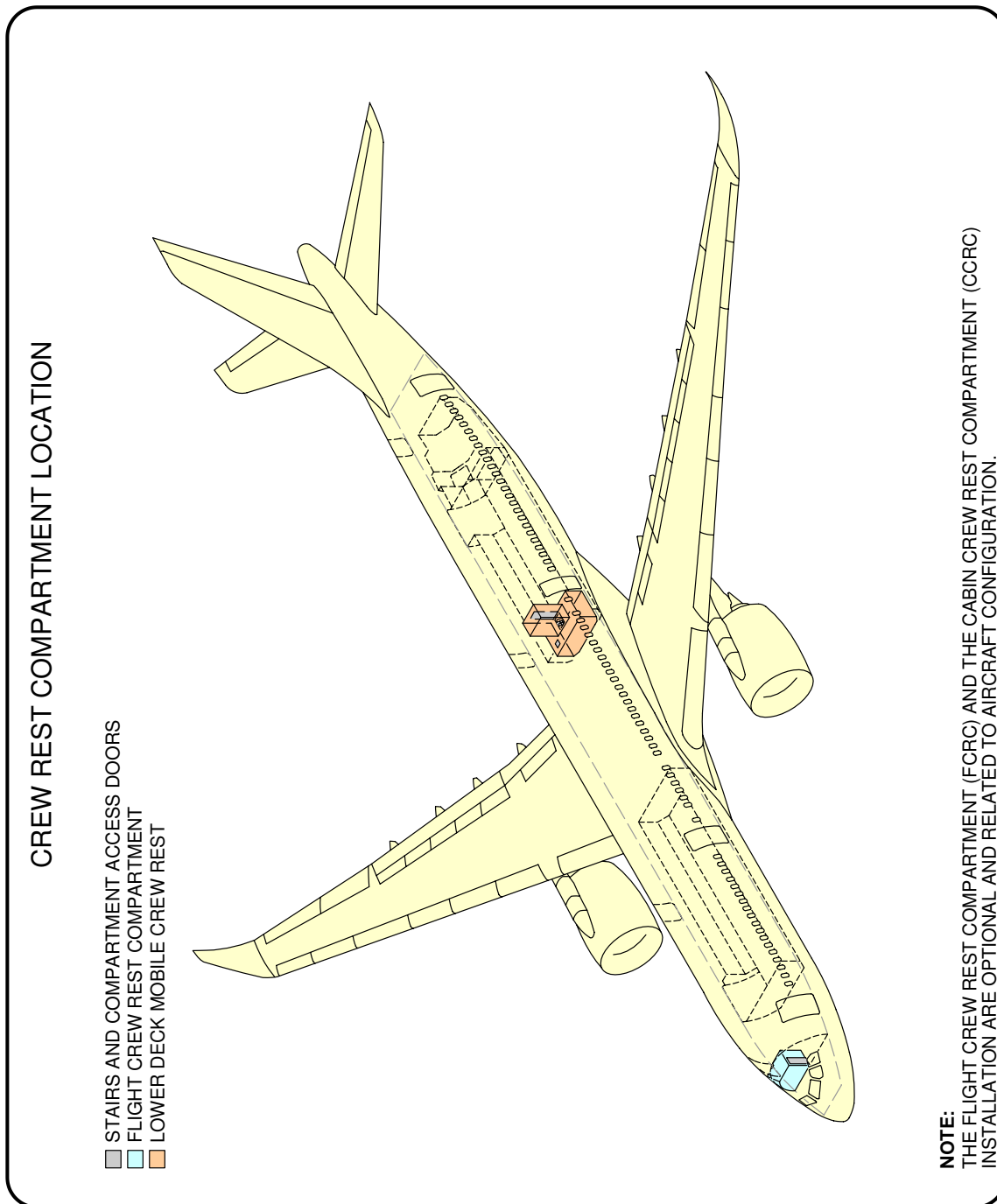

F_AC_100000_1_0750101_01_00

Crew Rest Compartments Location
(Sheet 1 of 2)

FIGURE-10-0-0-991-075-A01

**ON A/C A330-800 A330-900

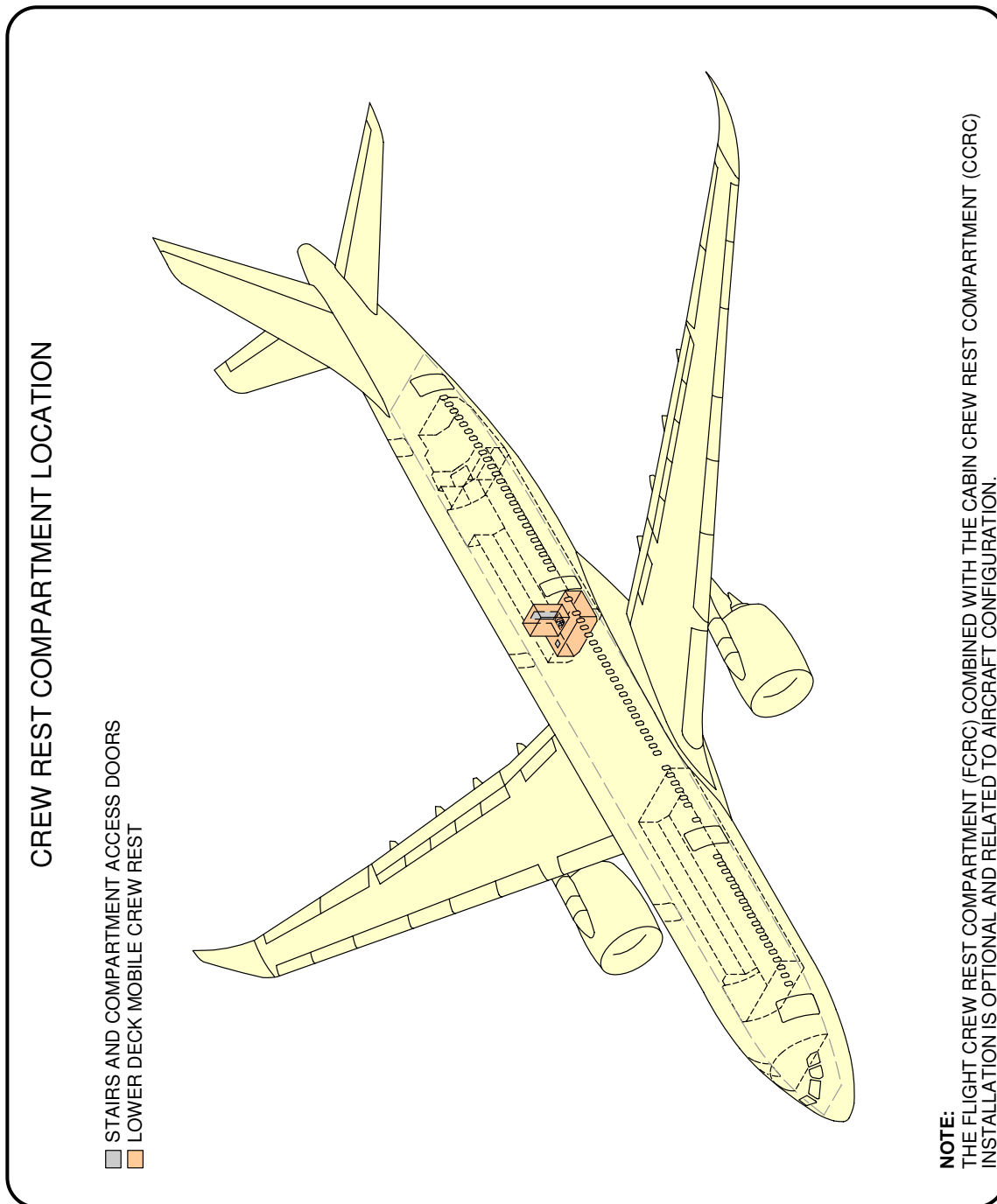

F_AC_100000_1_0750102_01_00

Crew Rest Compartments Location
(Sheet 2 of 2)

FIGURE-10-0-0-991-075-A01

**ON A/C A330-800 A330-900

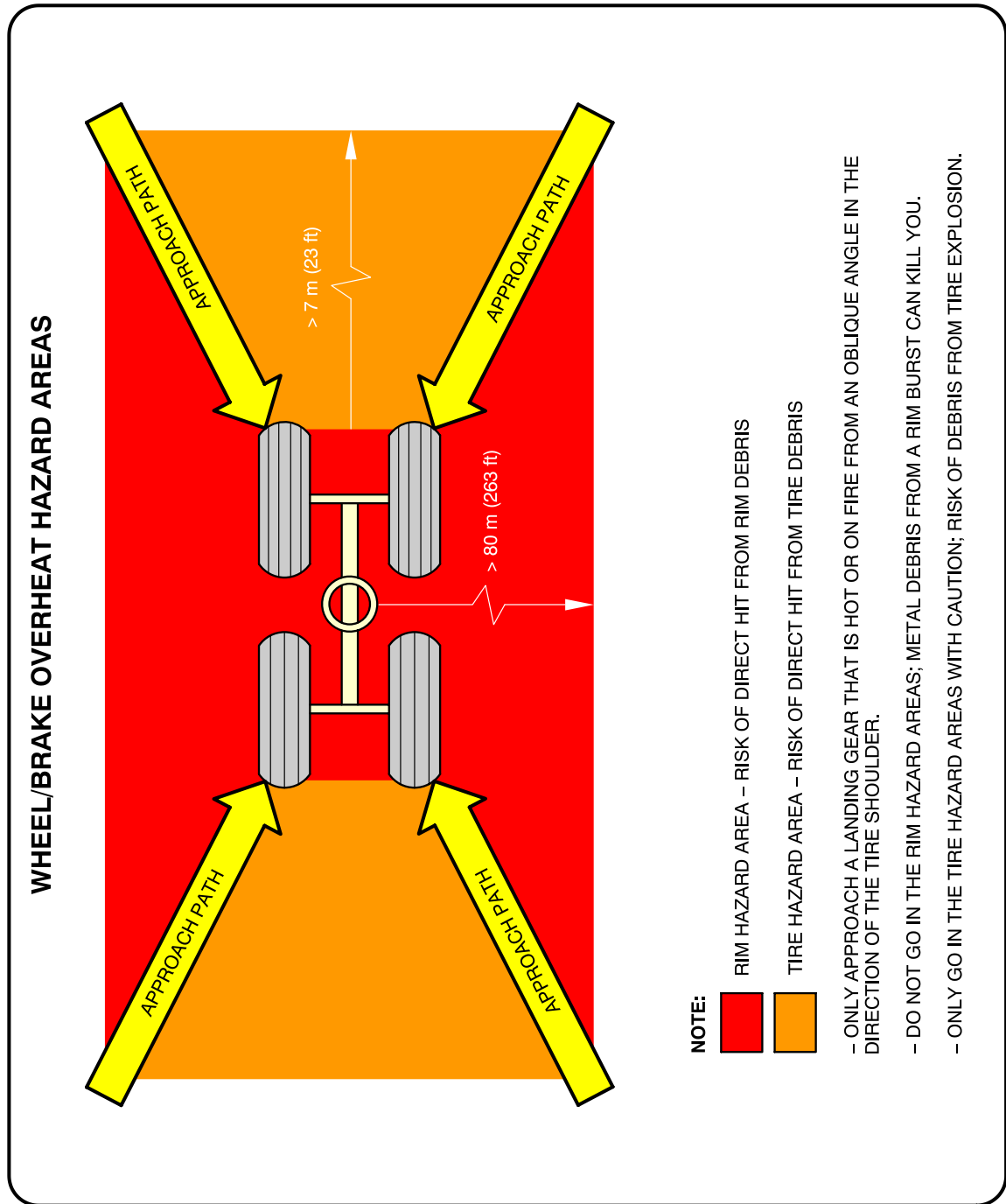

F_AC_100000_1_0760101_01_00

Wheel/Brake Overheat
Wheel Safety Area (Sheet 1 of 2)
FIGURE-10-0-0-991-076-A01

**ON A/C A330-800 A330-900

BRAKE OVERHEAT AND LANDING GEAR FIRE

WARNING: BE VERY CAREFUL WHEN THERE IS A BRAKE OVERHEAT AND/OR LANDING GEAR FIRE. THERE IS A RISK OF TIRE EXPLOSION AND/OR WHEEL RIM BURST THAT CAN CAUSE DEATH OR INJURY. MAKE SURE THAT YOU OBEY THE SAFETY PRECAUTIONS THAT FOLLOW.

THE PROCEDURES THAT FOLLOW GIVE RECOMMENDATIONS AND SAFETY PRECAUTIONS FOR THE COOLING OF VERY HOT BRAKES AFTER ABNORMAL OPERATIONS SUCH AS A REJECTED TAKE-OFF OR OVERWEIGHT LANDING. FOR THE COOLING OF BRAKES AFTER NORMAL TAXI-IN, REFER TO YOUR COMPANY PROCEDURES.

BRAKE OVERHEAT:

- 1 – GET THE BRAKE TEMPERATURE FROM THE COCKPIT OR USE A REMOTE MEASUREMENT TECHNIQUE. THE REAL TEMPERATURE OF THE BRAKES CAN BE MUCH HIGHER THAN THE TEMPERATURE SHOWN ON THE ECAM.
NOTE: AT HIGH TEMPERATURES (>800°C), THERE IS A RISK OF WARPING OF THE LANDING GEAR STRUTS AND AXLES.
- 2 – APPROACH THE LANDING GEAR WITH EXTREME CAUTION AND FROM AN OBLIQUE ANGLE IN THE DIRECTION OF THE TIRE SHOULDER. DO NOT GO INTO THE RIM HAZARD AREA AND ONLY GO IN THE TIRE HAZARD AREA WITH CAUTION. (REF FIG. WHEEL/BRAKE OVERHEAT HAZARD AREAS). IF POSSIBLE, STAY IN A VEHICLE.
- 3 – LOOK AT THE CONDITION OF THE TIRES:
IF THE TIRES ARE STILL INFLATED (FUSE PLUGS NOT MELTED), THERE IS A RISK OF TIRE EXPLOSION AND RIM BURST. DO NOT USE COOLING FANS BECAUSE THEY CAN PREVENT OPERATION OF THE FUSE PLUGS.
- 4 – USE WATER MIST TO DECREASE THE TEMPERATURE OF THE COMPLETE WHEEL AND BRAKE ASSEMBLY. USE A TECHNIQUE THAT PREVENTS SUDDEN COOLING. SUDDEN COOLING CAN CAUSE WHEEL CRACKS OR RIM BURST. DO NOT APPLY WATER, FOAM OR CO₂. THESE COOLING AGENTS (AND ESPECIALLY CO₂, WHICH HAS A VERY STRONG COOLING EFFECT) CAN CAUSE THERMAL SHOCKS AND BURST OF HOT PARTS.

LANDING GEAR FIRE:

- CAUTION:** AIRBUS RECOMMENDS THAT YOU DO NOT USE DRY POWDERS OR DRY CHEMICALS ON HOT BRAKES OR TO EXTINGUISH LANDING GEAR FIRES. THESE AGENTS CAN CHANGE INTO SOLID OR ENAMELED DEPOSITS. THEY CAN DECREASE THE SPEED OF HEAT DISSIPATION WITH A POSSIBLE RISK OF PERMANENT STRUCTURAL DAMAGE TO THE BRAKES, WHEELS OR WHEEL AXLES.
- 1 – IMMEDIATELY STOP THE FIRE:
 - A) APPROACH THE LANDING GEAR WITH EXTREME CAUTION FROM AN OBLIQUE ANGLE IN THE DIRECTION OF THE TIRE SHOULDER. DO NOT GO INTO THE RIM HAZARD AREA AND ONLY GO IN THE TIRE HAZARD AREA WITH CAUTION. IF POSSIBLE, STAY IN A VEHICLE.
 - B) USE LARGE AMOUNTS OF WATER, WATER MIST; IF THE FUEL TANKS ARE AT RISK, USE FOAM. USE A TECHNIQUE THAT PREVENTS SUDDEN COOLING. SUDDEN COOLING CAN CAUSE WHEEL CRACKS OR RIM BURST.
 - C) DO NOT USE FANS OR BLOWERS.

F_AC_100000_1_0760102_01_00

Wheel/Brake Overheat
Recommendations (Sheet 2 of 2)
FIGURE-10-0-0-991-076-A01

**ON A/C A330-800 A330-900

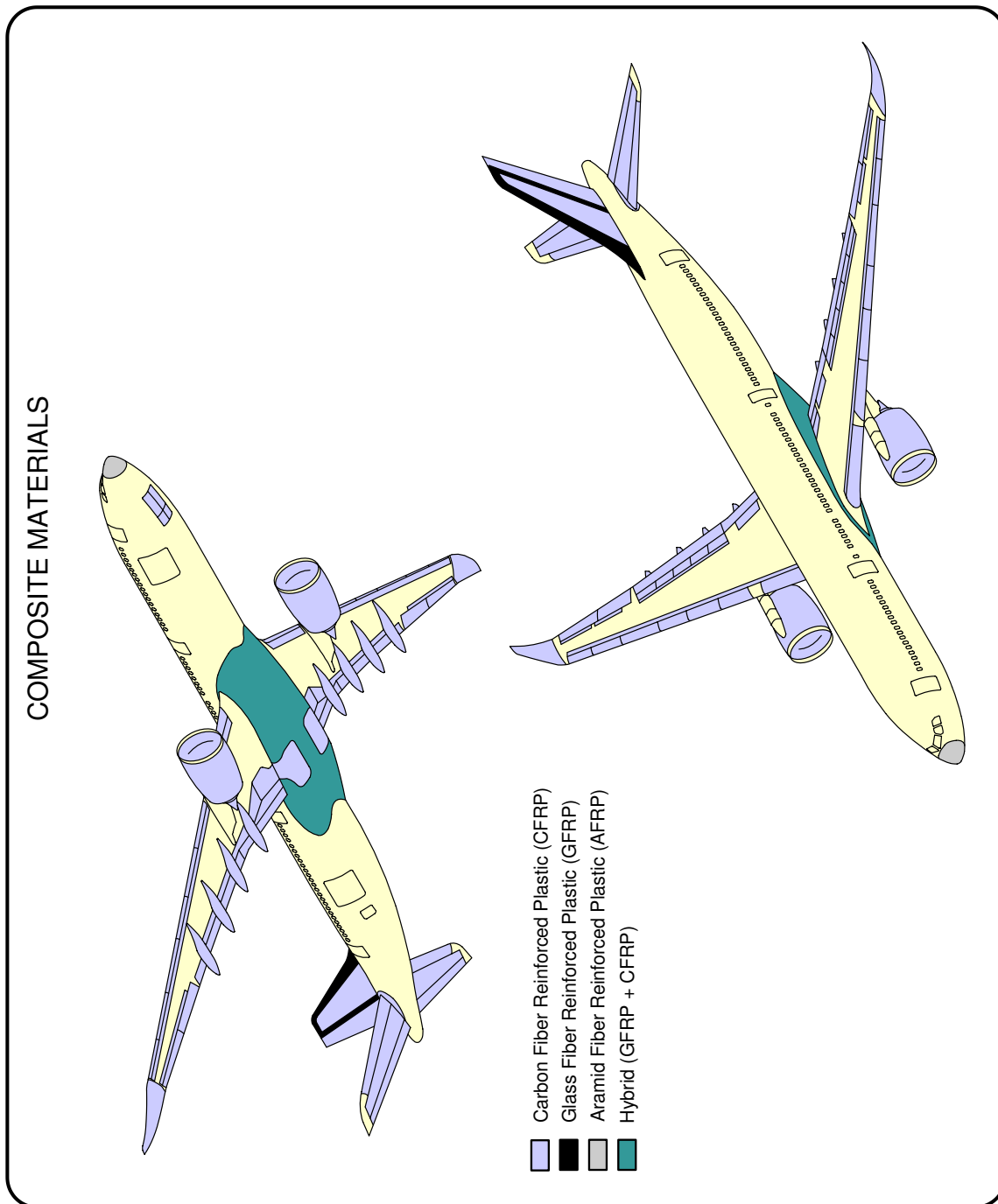

F_AC_100000_1_0770101_01_00

Composite Materials Location
FIGURE-10-0-0-991-077-A01

**ON A/C A330-800 A330-900

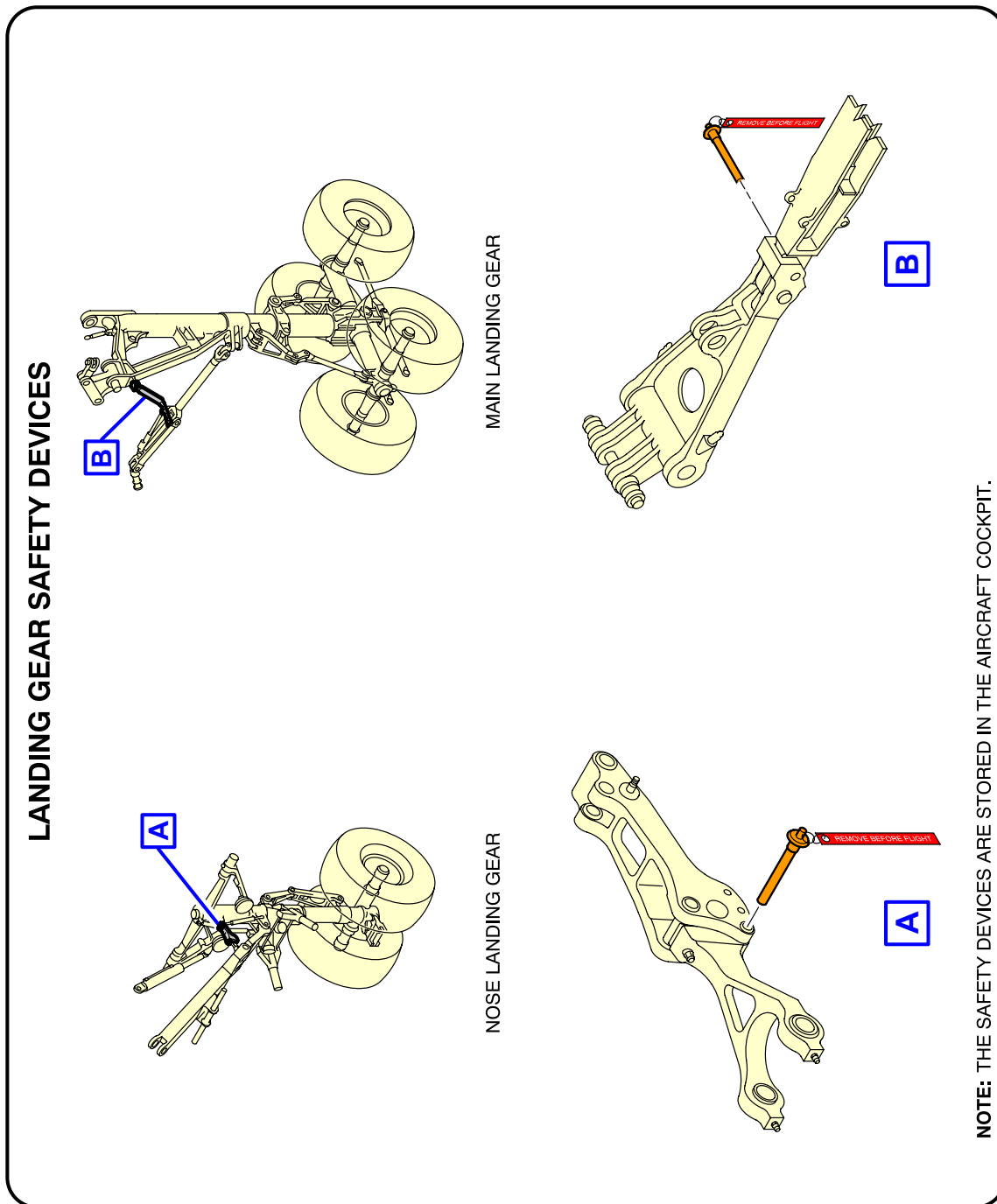

F_AC_100000_1_0780101_01_00

Ground Lock Safety Devices
FIGURE-10-0-0-991-078-A01

**ON A/C A330-800 A330-900

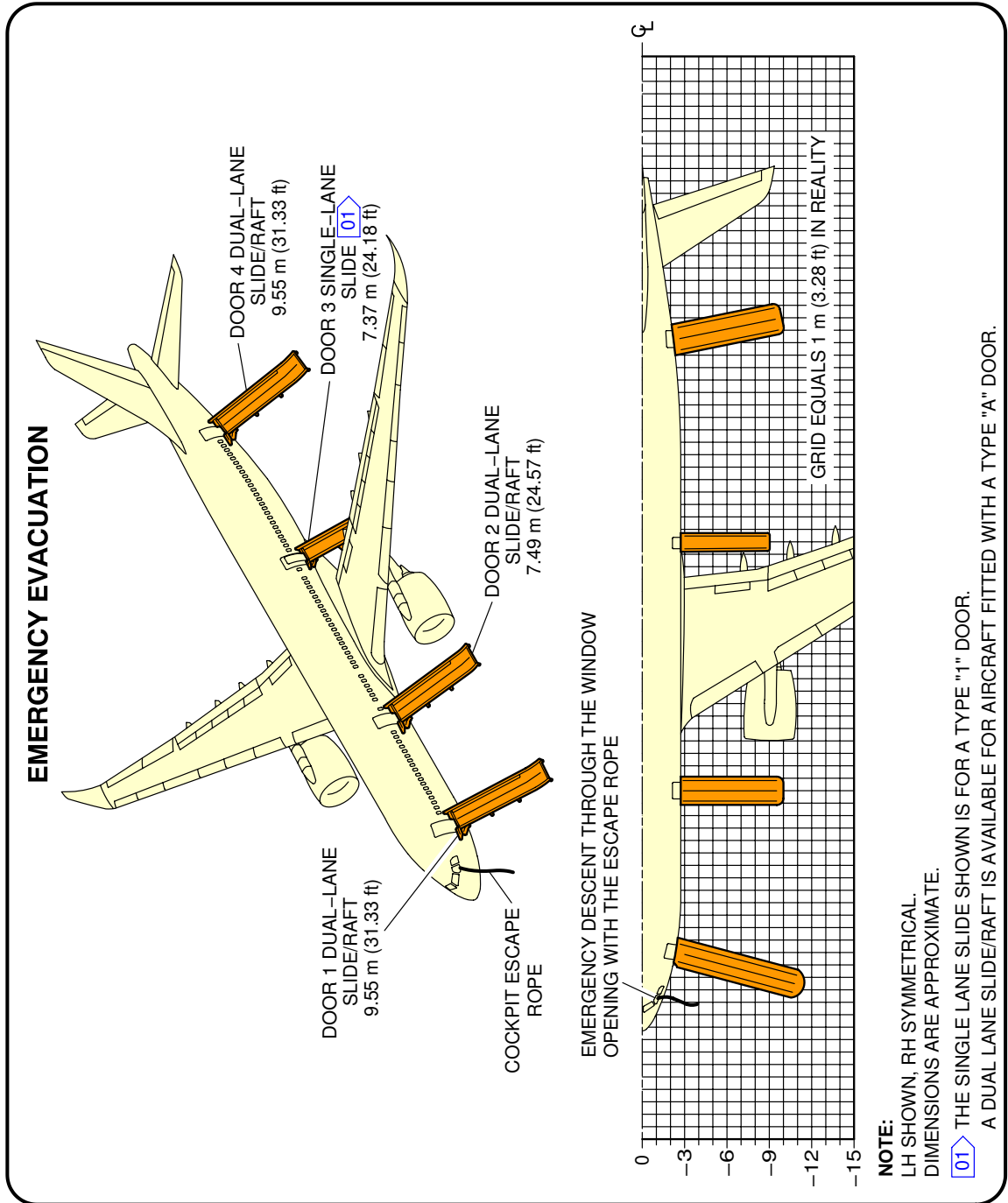

F_AC_100000_1_0790101_01_01

Emergency Evacuation Devices
FIGURE-10-0-0-991-079-A01

**ON A/C A330-800 A330-900

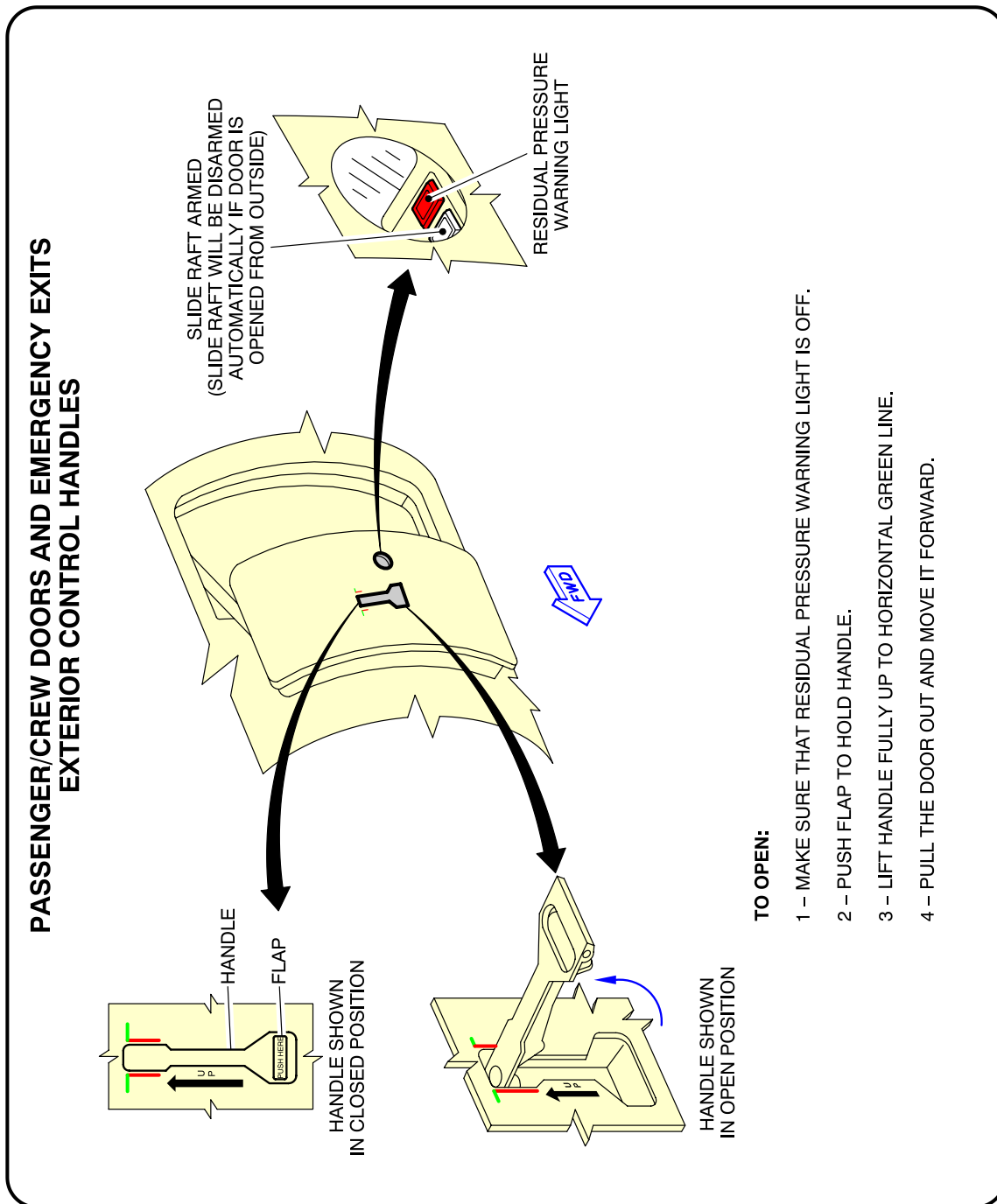

F_AC_100000_1_0800101_01_00

Pax/Crew Doors and Emergency Exits
FIGURE-10-0-0-991-080-A01

**ON A/C A330-800 A330-900

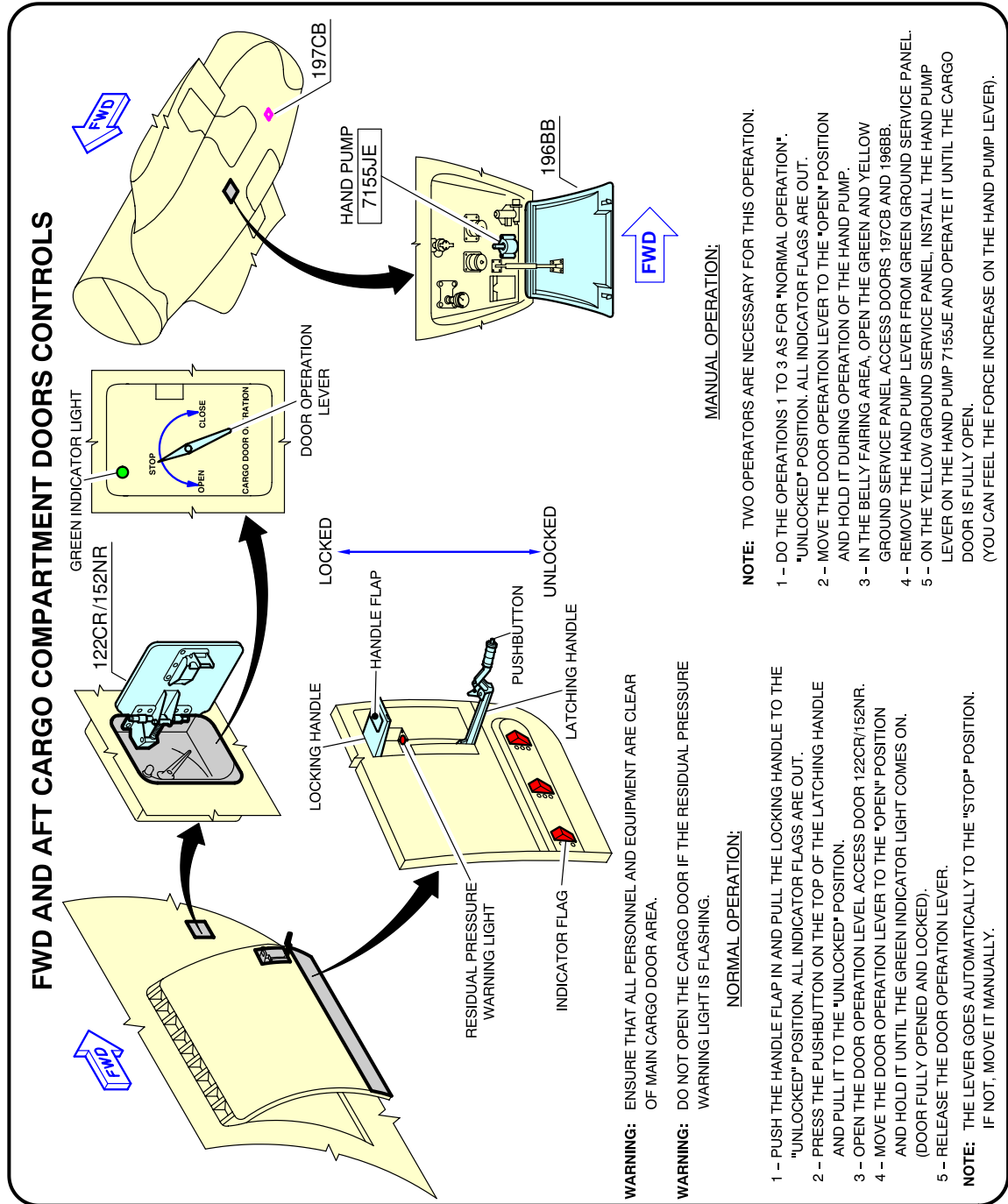

F_AC_100000_1_0810101_01_00

FWD and AFT Lower Deck Cargo Doors
FIGURE-10-0-0-991-081-A01

**ON A/C A330-800 A330-900

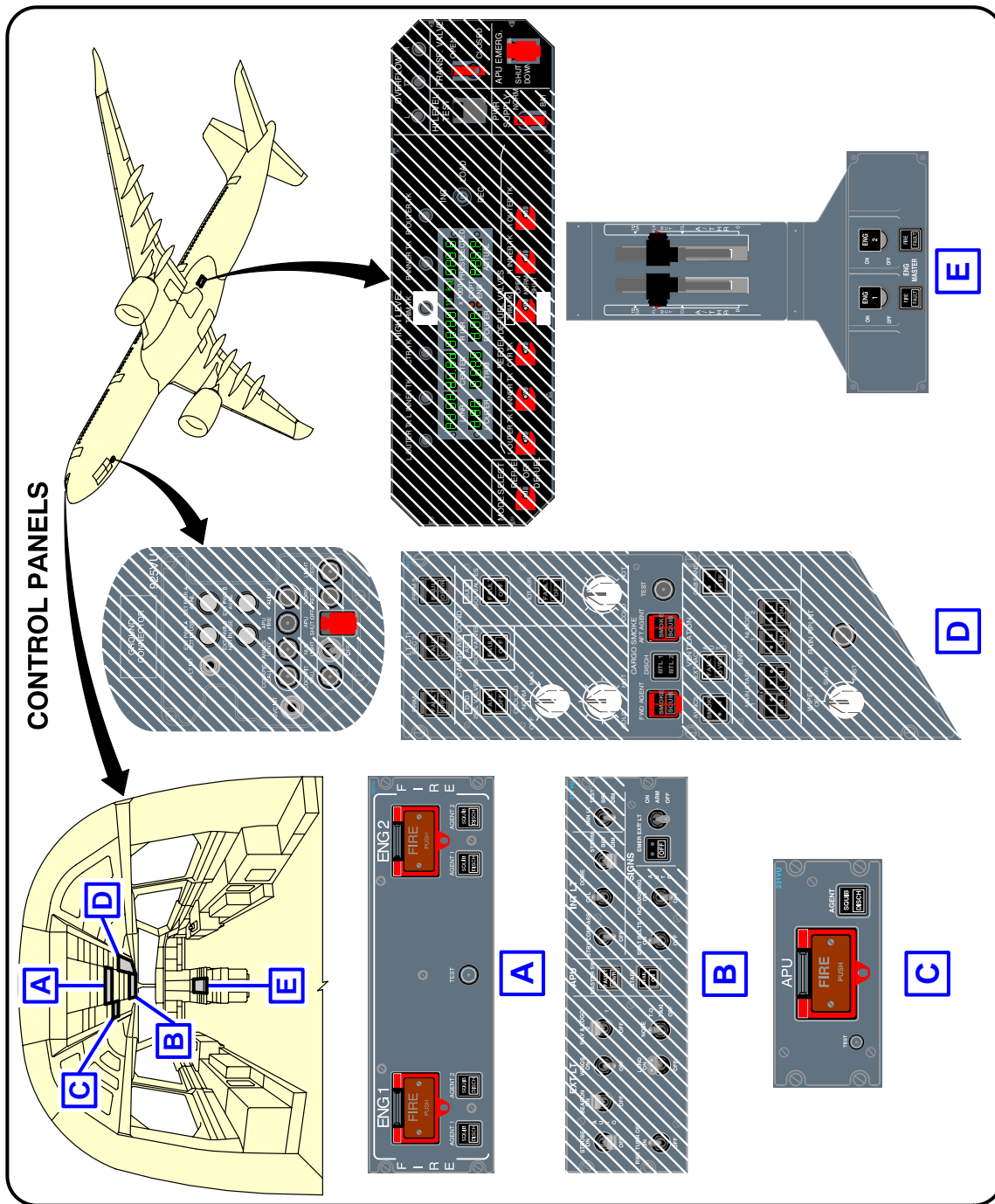

F_AC_100000_1_0820101_01_00

Control Panels
FIGURE-10-0-0-991-082-A01

**ON A/C A330-800 A330-900

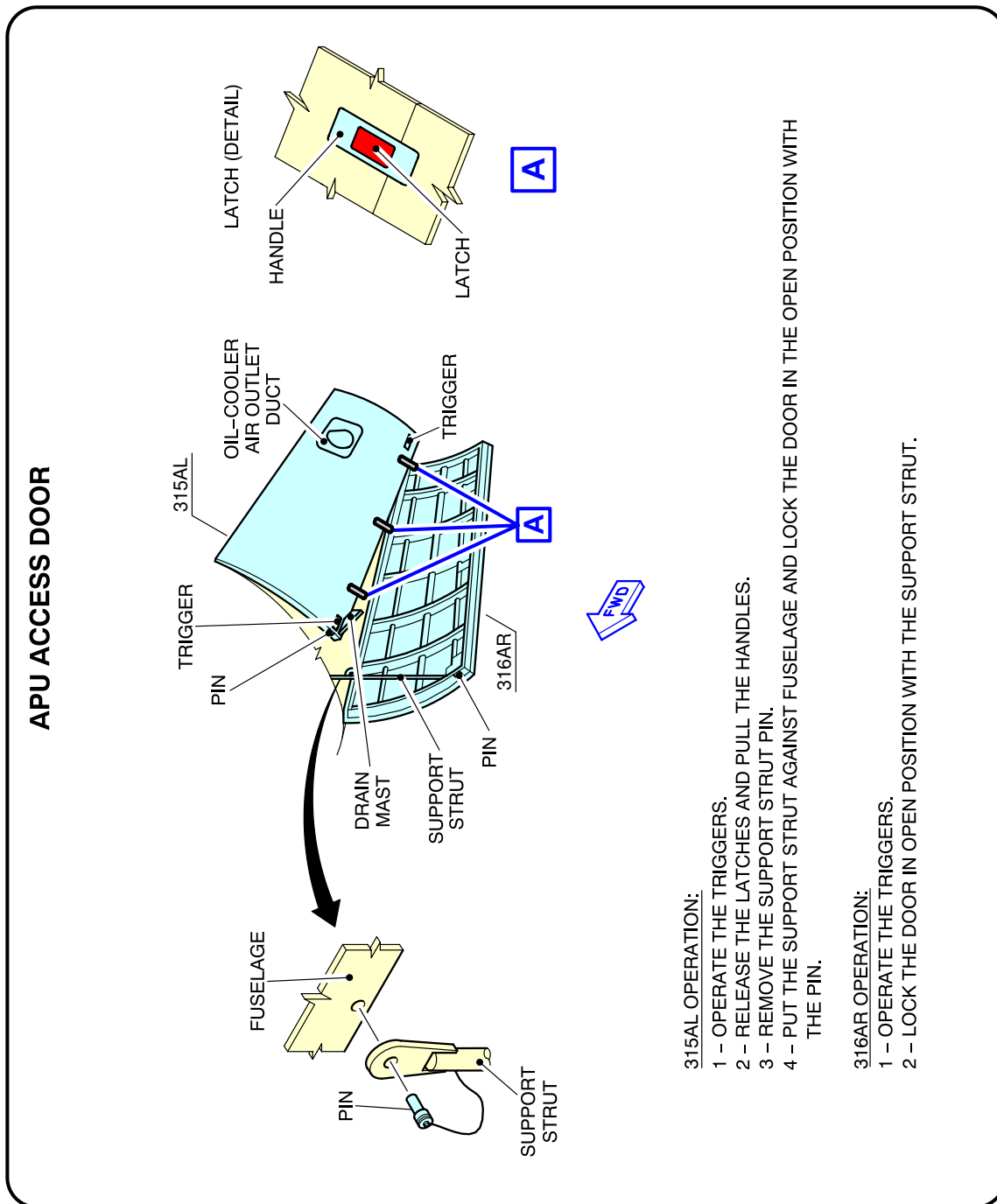

F_AC_100000_1_0830101_01_00

APU Compartment Access
FIGURE-10-0-0-991-083-A01

****ON A/C A330-800 A330-900**

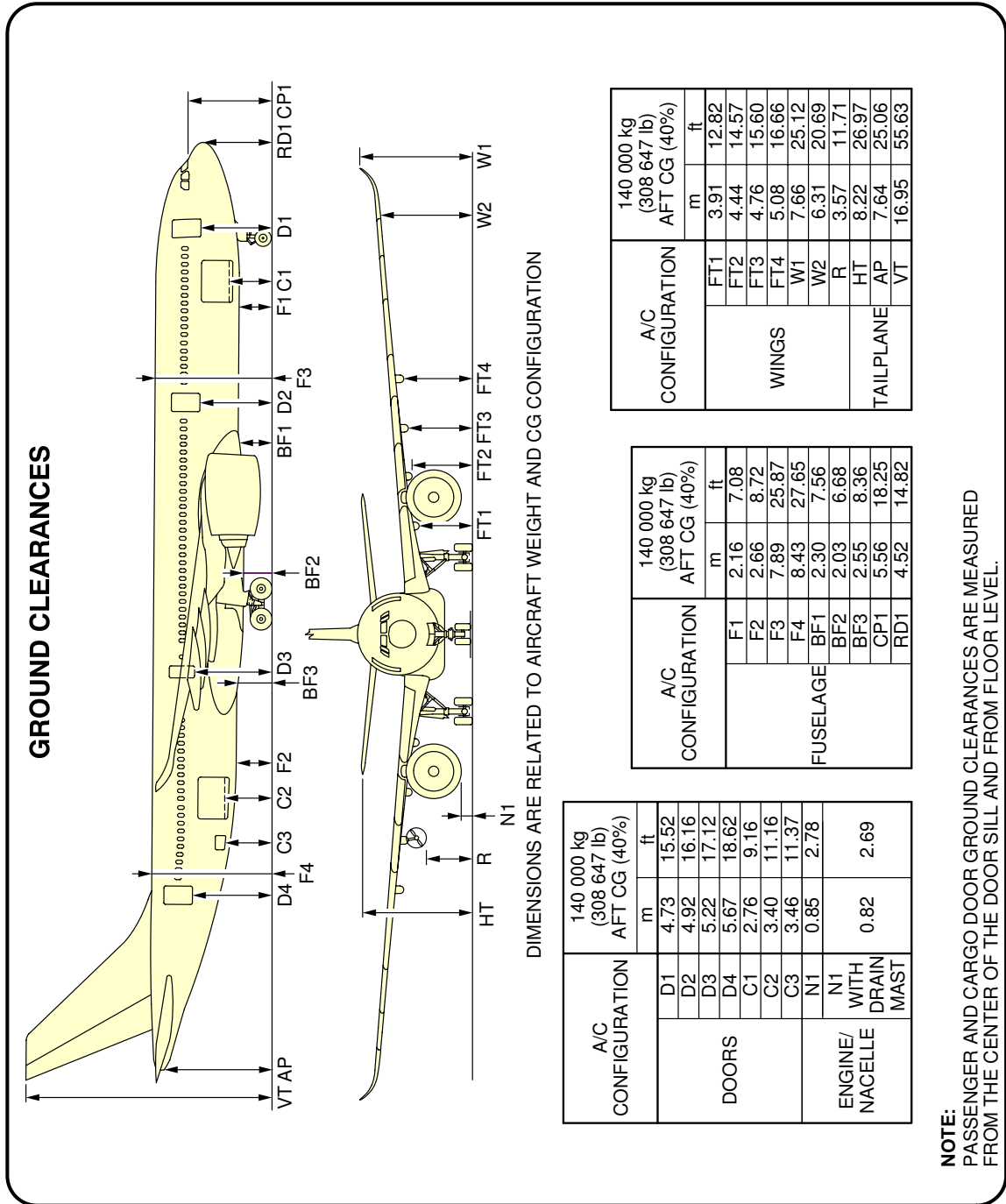

F_AC_100000_1_0840101_01_00

Ground Clearances
FIGURE-10-0-0-991-084-A01

**ON A/C A330-800 A330-900

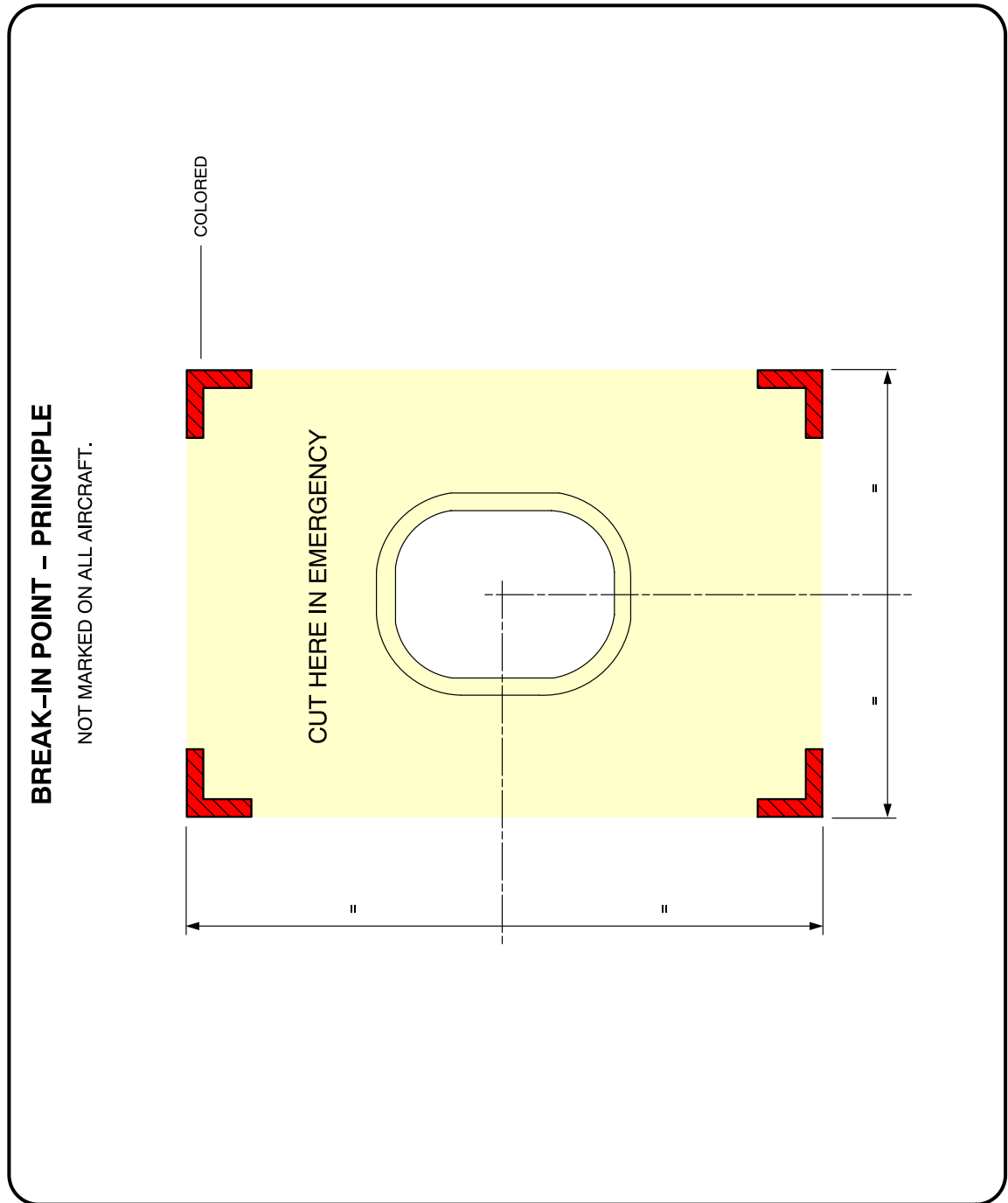

F_AC_100000_1_0850101_01_00

Structural Break-in Points
FIGURE-10-0-0-991-085-A01